

DRAGON-X

DX1-xx-L60W

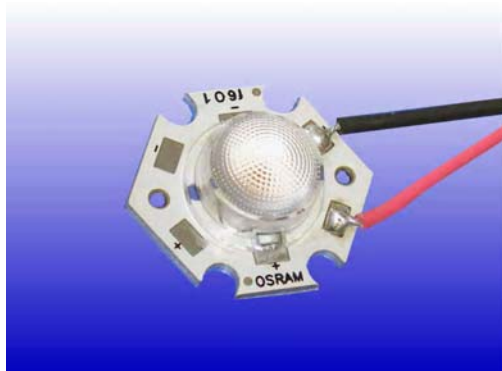
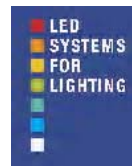

Benefits

- High-Flux LED Golden DRAGON® on metal core PCB with cables
- Compact module for freedom of design
- Integrated 60° optics for very wide flood

Applications

- Small / Portable / Battery powered light sources
- Effect / Architectural lighting
- Architectural luminaires

Technical Operating Data

Product	Color	Number of LEDs	Current [mA]*	Power [W]*	Radiance Angle [°]*	Wavelength [nm] Color Temp [K]*	Lum. Intensity [cd]*
DX1-W3-865-L60W +	white	1	350	1,2	60	6500 K	33
DX1-W3-854-L60W +	white	1	350	1,2	60	5400 K	33
DX1-W3-733-L60W +	white	1	350	1,2	60	3300 K	22
DX1-A2-L60W +	red	1	350	0,8	60	616 nm	33
DX1-Y2-L60W +	yellow	1	350	0,8	60	589 nm	15
DX1-T2-L60W +	green	1	350	1,2	60	525 nm	33
DX1-B2-L60W +	blue	1	350	1,2	60	468 nm	7

+) Preliminary Data

*) All Data are related to the entire module

Due to the special conditions of the manufacturing processes of LED the typical data of technical parameters can only reflect statistical figures and do not necessarily correspond to the actual parameters of each single product which could differ from the typical data.

Technical Features

- Ready to install with 200 mm cables AWG 24
- Easy assembly with M3 screws
- Dimensions for DX1-xx-L60W (L x W x H): 20 mm x 23 mm x 8.2 mm
- Integrated lens: 60° for very wide flood light
- Operation only with OPTOTRONIC® constant current devices (see page 3)
- Metal Core PCB for good heat dissipation
- Flammability according UL94: V0

Minimum and Maximum Ratings

Product	Operating Temperature at Tc-Point [°C] *	Storage Temperature [°C] *	Max. Current [A dc] *	Reverse Voltage [V dc] *
DX1-W3-865-L60W +	-30 ... 85	-30 ... 85	0,5	0
DX1-W3-854-L60W +	-30 ... 85	-30 ... 85	0,5	0
DX1-W3-733-L60W +	-30 ... 85	-30 ... 85	0,5	0
DX1-A2-L60W +	-30 ... 85	-30 ... 85	0,5	0
DX1-Y2-L60W +	-30 ... 85	-30 ... 85	0,5	0
DX1-T2-L60W +	-30 ... 85	-30 ... 85	0,5	0
DX1-B2-L60W +	-30 ... 85	-30 ... 85	0,5	0

The module is designed to work with current sources. The maximum output voltage may not exceed 100 V DC. Reverse operation is not allowed and may destroy the module.

*) Exceeding maximum ratings for operating and storage temperature will reduce expected life time or destroy the LED Module.
 Exceeding maximum ratings for operating current will cause hazardous overload and will likely destroy the LED Module. Several modules may be connected in series up to the maximum voltage of 100 V DC (outside SELV limits).
 The temperature of the LED module must be measured at the Tc-point according to EN60598-1 in a thermally constant status with a temperature sensor or a temperature sensitive label. For exact location of the Tc-point see drawing below.

Drawing

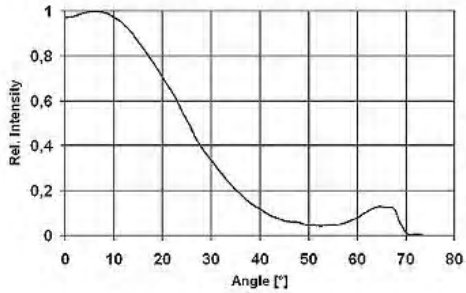
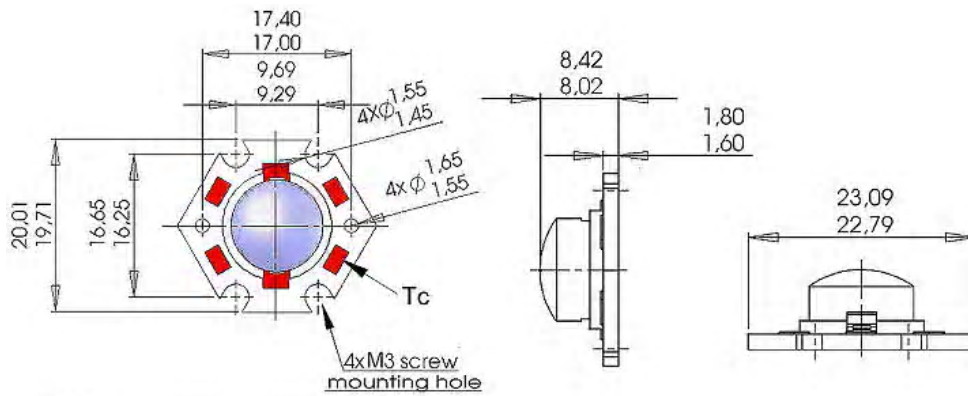

Light color	Max. Power @ 500 mA	Light output factor ^{*)} @ 500 mA
W3 / T2 / B2	1,7 W	x 1,3
Y2 / A2	1,2 W	x 1,3

*) If Tc is maintained

Safety Information

- The LED module itself and all its components must not be mechanically stressed.
- Assembly must not damage or destroy conducting paths on the circuit board.

The LED Module incorporates no protection against short circuits, overload or overheating. Therefore it is absolutely necessary to operate the modules with a electronically stabilised power supply offering protection against the above mentioned safety risks. For dimming applications attention should be paid to specific references in "OPTOTRONIC ® Technical Guide".

OSRAM OPTOTRONIC ® power supplies are specifically designed with protection features for safe operation.

When using power supplies other than OPTOTRONIC ® the following basic safety features are required, in addition to any other application specific concerns and local safety codes:

- Short circuit protection
 - Overload protection
 - Overheat protection
-
- Installation of LED modules (with power supplies) needs to be made with regard to all applicable electrical and safety standards. Only qualified personnel should be allowed to perform installations.
 - Correct electrical polarity needs to be observed. Wrong polarity may destroy the module and will result in no light emission.
 - Serial connection is highly recommended as safe electrical operation mode. Parallel connection is not recommended. Unbalanced voltage drop can cause hazardous overload and damage the LED module.
 - Pay attention to standard ESD precautions when installing the module.
 - Recommended power supply:
 - 1) 350 mA constant current operation: OT 9/200-240/350 or OT 9/100-120/350(E)
 - 2) 350 mA constant current PWM dimming, 1..10V interface: OT 9/10-24/350 DIM, OT 9/10-24/350 DIM(E)
 - 3) 0-350 mA constant current operation, 1..10 V interface (dimming), strain relief: OT 9/200-240/350 DIM
 - Maximum number of DX1 for all OT9: White/Blue/Green: 6; Red/Yellow: 9
 - 0-500 mA constant current operation, 1..10 V interface (dimming), strain relief: OT 18/200-240/700 DIM. The OT18 comes with preset limitation to 500mA, thus giving 12W due to SELV (<=25V)
 - Maximum number of DX1 for OT18: White/Blue/Green: 6; Red/Yellow: 9
 - The module, as manufactured, has no conformal coating and therefore offers no inherent protection against corrosion.
 - Damage by corrosion will not be honored as a materials defect claim. It is the user's responsibility to provide suitable protection against corrosive agents such as moisture and condensation and other harmful elements. For applications involving exposure to humidity and dust the module must be protected by a fixture or housing with a suitable protection class. The module can be protected against condensation water by treatment with an appropriate circuit board grade conformal coating. The conformal coating should have the following features:
 - Optical transparency
 - UV-resistance
 - Thermal expansion matching the thermal expansion of the module $40 \cdot 10^{-6}$ cm/cm/K
 - Low permeability of steam for all climatic conditions
 - Resistance against corrosive environment

Assembly Information

- The mounting of the module is facilitated by means of M3 screws on the screw hole of the metal-core circuit board (MCPCB). For the protection of the MCPCB the use of a plastic washer is recommended.
- The module should be mounted on a heat sink on lighting fixtures or luminaires. For the mounting 4 M3 screws are recommended to enable maximum heat sinking. For an optimum heat dissipation the module needs to be in good thermal contact with the designed metallic mounting surface. The use of an appropriate thermal interface material (e.g. thermal grease) is recommended to eliminate air gaps. The metal surface needs to be planar and clean (dirt and oil free).
- Do not apply traction-, shear- or peel-forces to the module during assembly. Pay attention to pull relief for the cable in the application.
- To obtain maximum LED lifetime please carefully read the recommended procedures concerning thermal management in our application note "Lifetime of LED-modules" before beginning construction of luminaires. This application note is available from your OSRAM representative or in the internet (see Related and Further Information).

Ordering Guide

Productgroup	Productname	EAN *	S-Unit *
DRAGON-X	DX1-W3-865-L60W +	4008321171498	120
DRAGON-X	DX1-W3-854-L60W +	4008321171573	120
DRAGON-X	DX1-W3-733-L60W +	4008321171658	120
DRAGON-X	DX1-A2-L60W +	4008321171764	120
DRAGON-X	DX1-Y2-L60W +	4008321171849	120
DRAGON-X	DX1-T2-L60W +	4008321172020	120
DRAGON-X	DX1-B2-L60W +	4008321171948	120

*) EAN: Ordering number per single module
S-Unit: Modules per shipping unit

Note: Typical performance data are subject to change without any further notice, particularly as LED technology evolves.

Sales and Technical Support

OSRAM GmbH

Hellabrunner Strasse 1
D - 81536 München
Germany
www.osram.com
+49 (0)89 6213-0

Sales and technical support is given by the local OSRAM subsidiaries.
On our world wide homepage all OSRAM subsidiaries are listed with complete address and phone numbers.

Related and Further Information

- OSRAM LED systems www.osram.com/led-systems
- OPTOTRONIC® Technical Guide 130 T008 GB
- OPTOTRONIC® Data Sheets <http://catalog.myosram.com>
- Datasheets DRAGON-X DX1 www.osram.com/led-systems-downloads
- Application Note: Life Expectancy www.osram.com/led-systems-downloads