

XCL219B333FR-G Evaluation Board User Manual

HiSAT-COT[®] Control 1.0A Inductor Built-in Step-Down “micro DC/DC” Converters

CAUTION

ENGINEERING EVALUATION PURPOSES ONLY

This evaluation board is made for the purpose of the product evaluation.
It is strictly prohibited to use this evaluation board for any other purpose.

Torex Semiconductor does not guarantee that all samples will perform in exactly the same way and we recommend that you always consult our product data sheets for the minimum and maximum specifications.

It is also important that you evaluate all our products carefully before mass

XCL219B333FR-G Evaluation Board

Inductor Built-in synchronous step-down micro DC/DC converte

Evaluation Board Picture



Evaluation Board SPEC

						Ta=25°C
		CONDITON.	MIN.	TYP.	MAX.	UNIT
Vin	Input Voltage Range	-	2.5	-	5.5	V
Vout	Setting Output Voltage	-	-	3.3	-	V
Iout	Output Current	-	0	-	1000	mA
fosc	Switching frequency	-	-	3.0	-	MHz

XCL219/XCL220 Series Features

- Input Voltage Range 2.5V ~ 5.5V
- Output Voltage Range 0.8V ~ 3.6V (step 0.05V)
- Max Output Current 1000mA max.
- Switching frequency 3MHz
- Max Duty Cycle 100%

- Fast Load Transient Response
- Built-in Inductor
- Low EMI Noise

XCL219B333FR-G Evaluation Board

Inductor Built-in synchronous step-down micro DC/DC converter

Quick Start Procedure

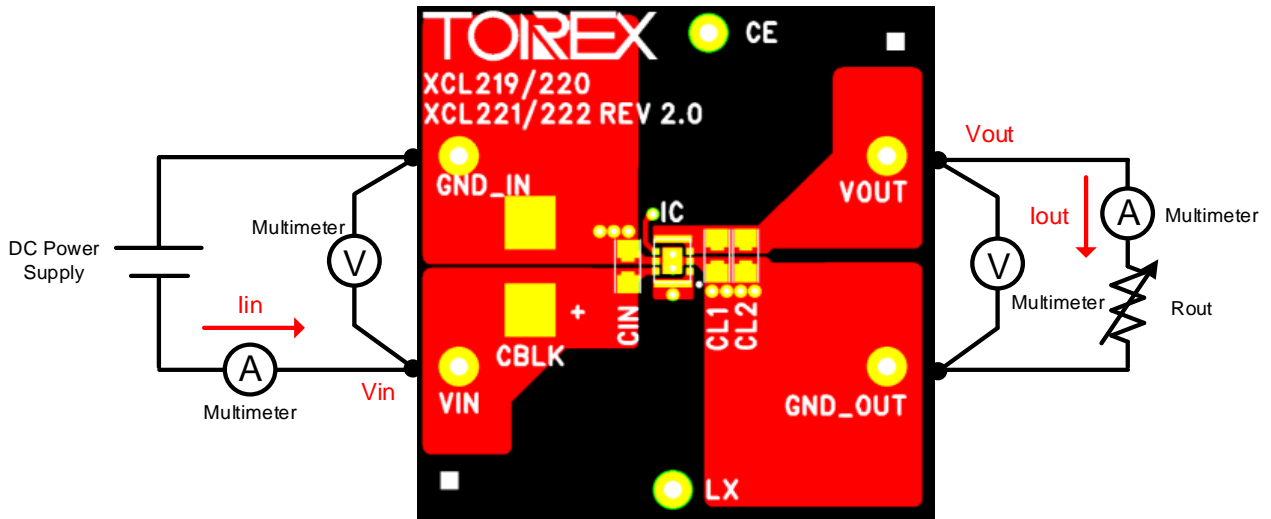

XCL219B333FR-G Evaluation Board

Inductor Built-in synchronous step-down micro DC/DC converter

Schematic

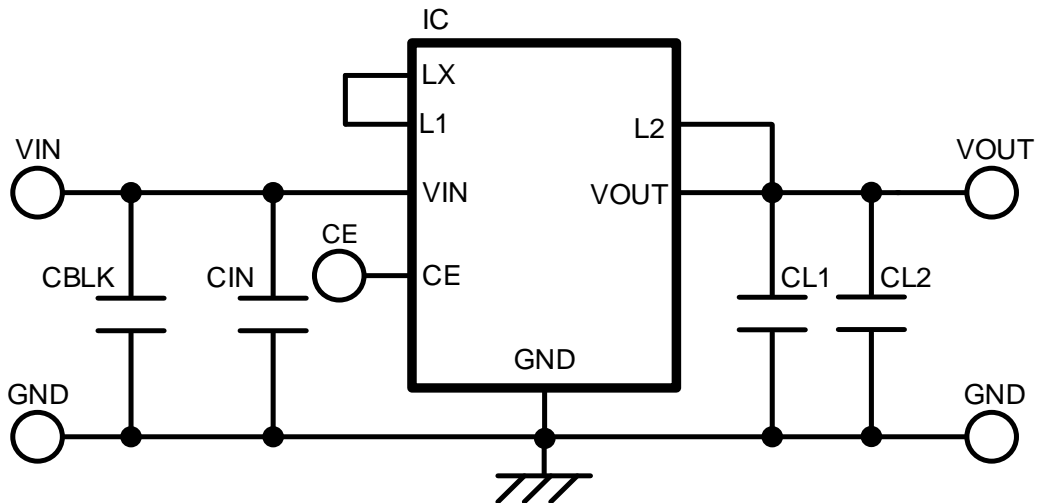

BOM

Required Circuit Component

Item	Value	Description	Size [mm]	Part Number	Manufacture
IC	-	Step-Down micro DC/DC Converters	CL-2025-02	XCL219B333FR-G	TOREX
CIN	10uF	Ceramic cap., 10V/10uF	1608	LMK107BBJ106MALT	Taiyo Yuden
CL1	10uF	Ceramic cap., 10V/10uF	1608	LMK107BBJ106MALT	Taiyo Yuden
CL2	10uF	Ceramic cap., 10V/10uF	1608	LMK107BBJ106MALT	Taiyo Yuden

Additional Demo Board Circuit Components

Item	Value	Description	Size [mm]	Part Number	Manufacture
CBLK	10uF	Ceramic cap., 50V/10uF	3225	CGA6P3X7S1H106K	TDK

XCL219B333FR-G Evaluation Board

Inductor Built-in synchronous step-down micro DC/DC converter

PCB Layout

Layer 1

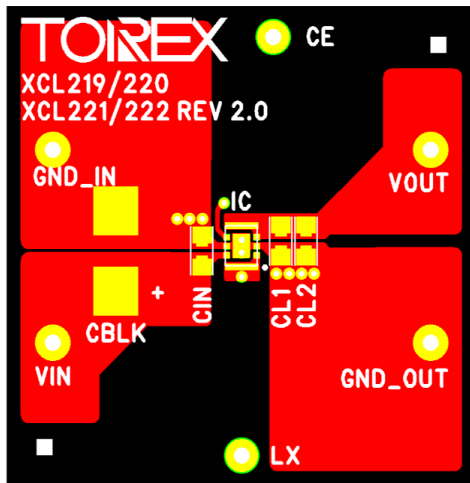

Layer 2

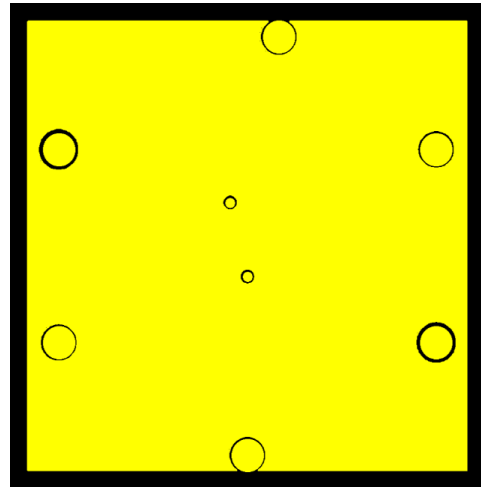

Layer 3

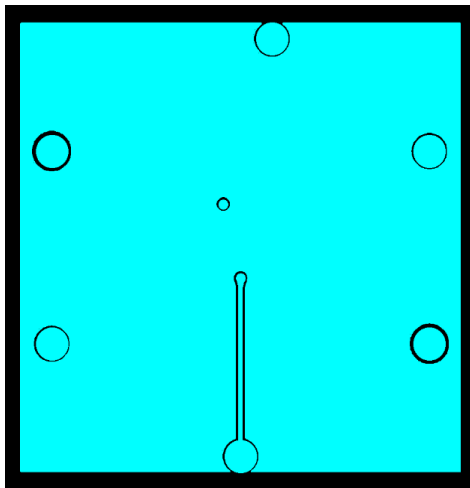

Layer 4

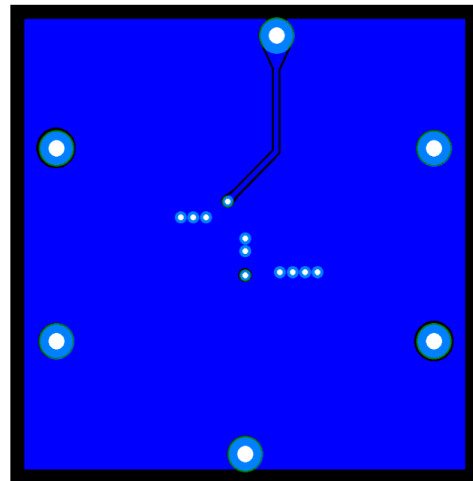

XCL219B333FR-G Evaluation Board

Inductor Built-in synchronous step-down micro DC/DC converte

Test Result

(1) Output Voltage vs Output Current @Ta=25°C

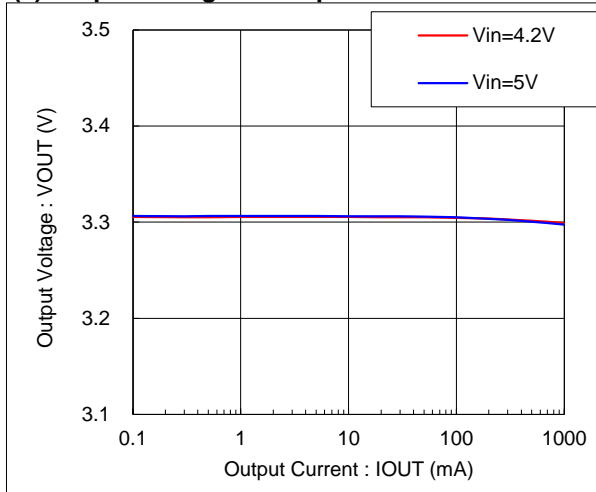

(2) Efficiency vs Output Current Ta=25°C

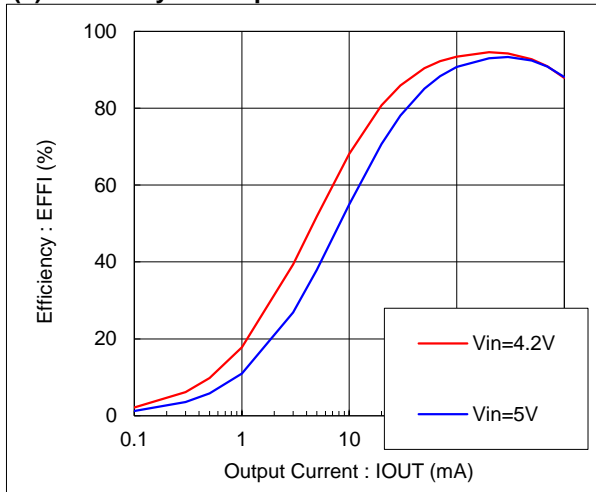

(3) Ripple Voltage vs Output Current Ta=25°C

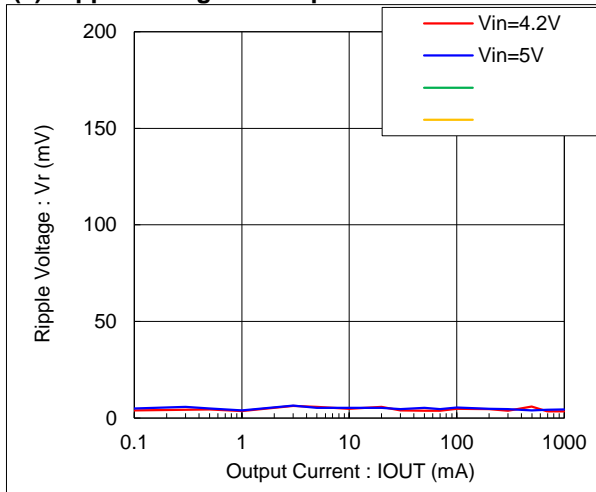

XCL219B333FR-G Evaluation Board

Inductor Built-in synchronous step-down micro DC/DC convertor

Test Result

(4) Output Voltage Waveform @ Ta=25°C

(4-1) Vin = 5V, Iout = 1mA

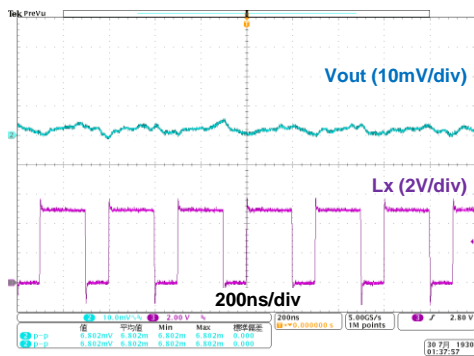

(4-2) Vin = 5V, Iout = 300mA

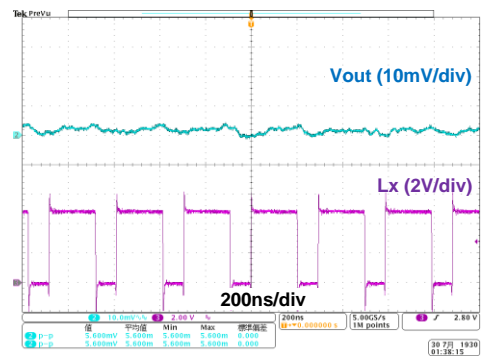

XCL219B333FR-G Evaluation Board

Inductor Built-in synchronous step-down micro DC/DC converter

Test Result

(5) Start-up Waveform @ Ta=25°C

(5-1) Vin = 5V, Iout = 10mA

(5-2) Vin = 5V, Iout = 300mA

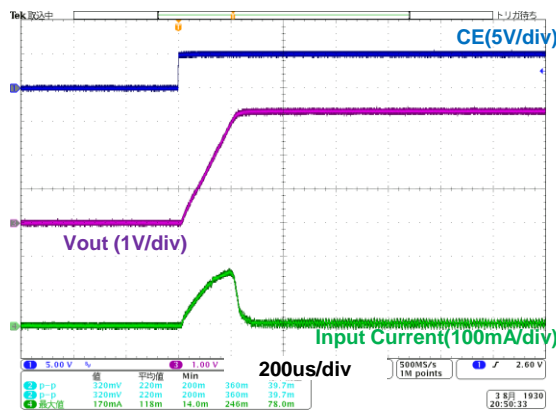
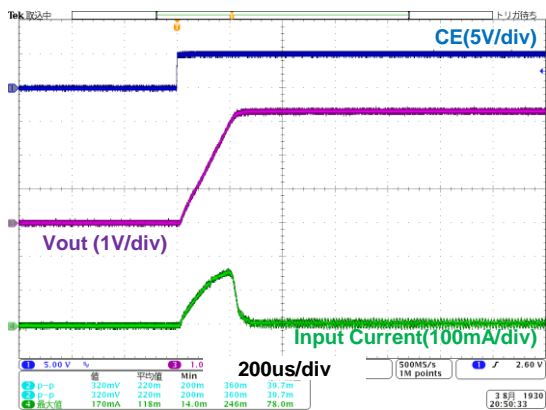

XCL219B333FR-G Evaluation Board

Inductor Built-in synchronous step-down micro DC/DC converter

Test Result

(6) Load Transient Waveform @ Ta=25°C

(6-1) Vin = 5V, Iout = 1mA ↔ 300mA

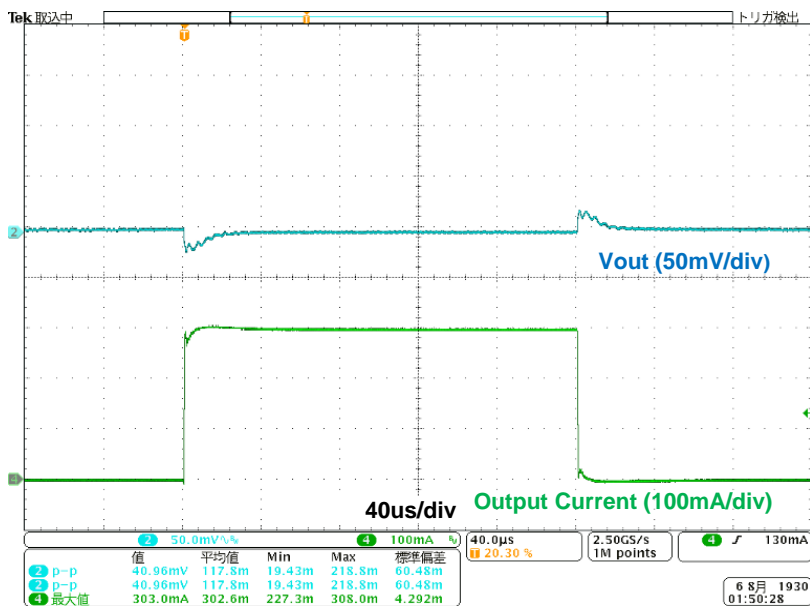

XCL219B333FR-G Evaluation Board

Inductor Built-in synchronous step-down micro DC/DC converter

【Appendix】 How to calculate DC/DC Converter or DC/DC Controller.

It can be calculated by the following "WEB DC/DC Simulation".

Product	XCL219 Product Info
Switching frequency	3000 [kHz]
Control Method	F-PWM
Sim Condition	
Vin	5 [V] Range: 2.5V~5.5V
Vout	3.3 [V] Range: 0.8V~3.6V
Iout	100 [mA] Range: 0~1000mA
Rvin (Battery Impedance etc)	0 [Ω]
Ta	25 [°C] Range: -40~105°C
Thermal resistance: θja	100 [°C/W] Range: 0~1000°C/W
External Components	
CL (Effective Value)	5 [μF]
ESR	5 [mΩ]



- 日本語 : <https://www.torex.co.jp/technical-support/dcdc-simulation/>
- English : <https://www.torexsemi.com/technical-support/dcdc-simulation/>
- 简体中文 : <https://www.torex.com.cn/technical-support/dcdc-simulation/>

XCL219B333FR-G Evaluation Board

Inductor Built-in synchronous step-down micro DC/DC converter

[Appendix] How to reduce the spike noise caused by measurement (Probing method with oscilloscope)

Probing method : Before improvement

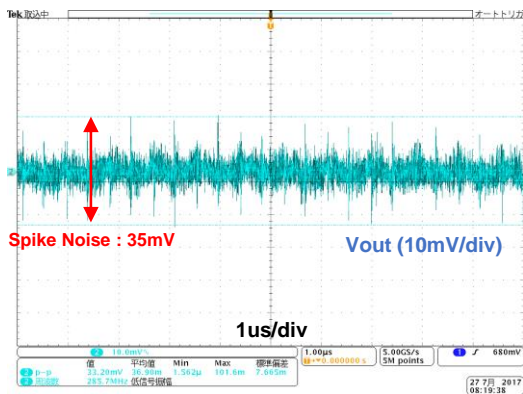
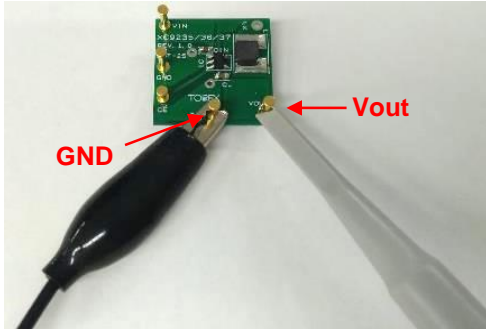

Probing method : After

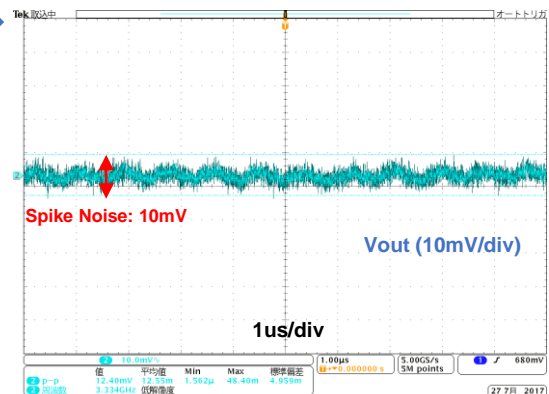
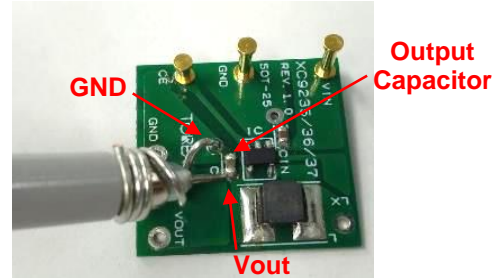

* Condition : XC9236, Vin=3.6V/Vout=1.8V/100mA

English : <https://www.torexsemi.com/technical-support/tips/reduction-spike-noise/>

日本語 : <https://www.torex.co.jp/technical-support/tips/reduction-spike-noise/>