

Spezifikation für Freigabe / specification for release

Kunde / customer :
 Artikelnummer / part number : **74941000**
 Bezeichnung : **WE-BMS**
 description : **Transformer for Battery Management Systems**

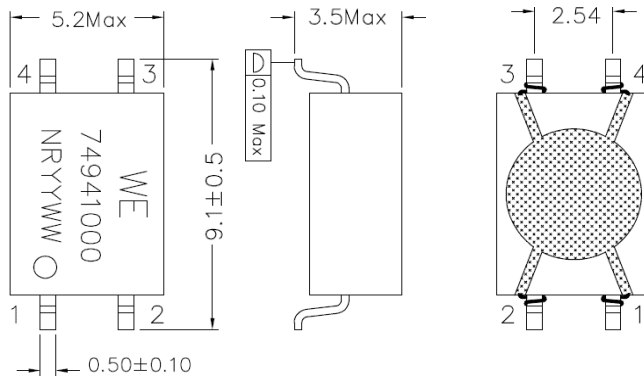

A Mechanische Abmessungen / dimensions : [mm]



Unless otherwise specified, tolerance is ± 0.25 .

B Elektrische Eigenschaften / electrical properties :

Eigenschaften / properties	Testbedingungen / test conditions		Wert / value	Einheit / unit	tol.
Induktivität / Inductance	100kHz / 100mV @ +25°C	OCL	125	uH	min.
Induktivität / Inductance	100kHz / 100mV @ -40°C	OCL	120	uH	min.
Übersetzungsverhältnis / Turns ratio	100kHz / 100mV	TR	1 : 1	(1-2):(4-3)	3%
DC resistance	1-2		0.250	ohms	max.
DC resistance	3-4		0.250	ohms	max.

C Lötpad / soldering spec. : [mm]

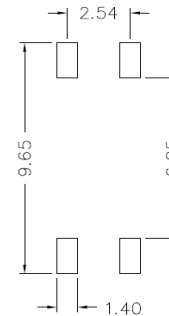

D Prüfgeräte / test equipment :

HP4395A

E Testbedingungen / test conditions :

Luftfeuchtigkeit / humidity: 33%
 Umgebungstemperatur / temperature: +25°C

F Werkstoffe & Zulassungen / material & approvals :

Basismaterial / base material: Ferrit/ ferrite
 Draht / wire: FIW 4, reinforced insulation
 Kontaktmaterial/ contact plating: Cu-Ni-Sn
 Gehäuse / case: WH9100, UL94-V0, CTI>600V
 Verguss / potting: Epoxy UL94-V0, CTI 600V

G Eigenschaften / general specifications :

Betriebstemp. / operating temperature: -40°C - +125°C
 Hochspannungsprüfung / Hipot test: 3000Vrms, 1 minute.
 Kriechstrecke / Creepage distance: 4 mm min.
 Arbeitsspannung / Working voltage: 800VDC.

Freigabe erteilt / general release:	Kunde / customer		
.....		
Datum / date	Unterschrift / signature		
	Würth Elektronik	JefL	Revision 03 2020-12-16
		JefL	Revision 02 2020-04-08
		JefL	Revision 01 2019-11-26
Geprüft / checked	Kontrolliert / approved	Name	Änderung / modification Datum / date

Würth Elektronik eiSos GmbH & Co.KG

D-74638 Waldenburg · Max-Eyth-Straße 1 - 3 · Germany · Telefon (+49) (0) 7942 - 945 - 0 · Telefax (+49) (0) 7942 - 945 - 400
<http://www.we-online.com>

Spezifikation für Freigabe / specification for release

Kunde / customer :
 Artikelnummer / part number : **74941000**
 Bezeichnung : **WE-BMS**
 description : **Transformer for Battery Management Systems**



H Schaltbild / Schematics :

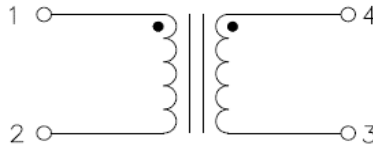

I Rollenspezifikation / tape and reel specification :

Gurtspezifikation / Tape specification:

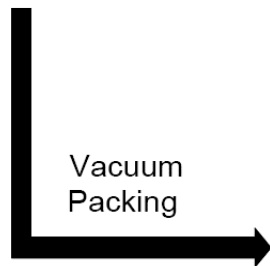
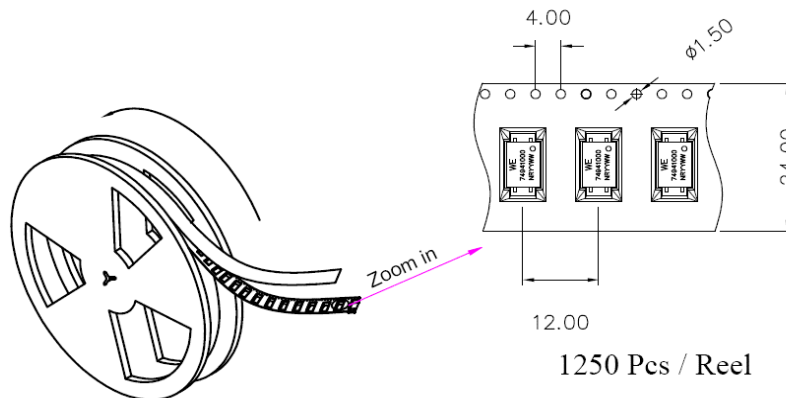

Outside Carton

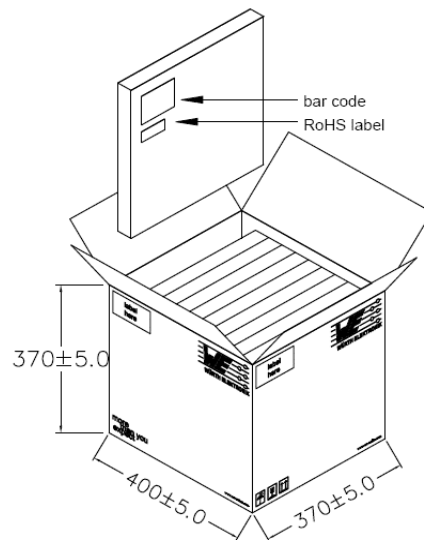

PACKING QUANTITY:

1250pcs Finished Goods / Reel

10 Reels (12500pcs Finished Goods) / Carton

Datum / date	Unterschrift / signature																
	Würth Elektronik																
Geprüft / checked	Kontrolliert / approved																
		<table border="1" style="width: 100%; border-collapse: collapse;"> <tr><td></td><td></td><td></td></tr> <tr><td>JefL</td><td>Revision 03</td><td>2020-12-16</td></tr> <tr><td>JefL</td><td>Revision 02</td><td>2020-04-08</td></tr> <tr><td>JefL</td><td>Revision 01</td><td>2019-11-26</td></tr> <tr><td>Name</td><td>Änderung / modification</td><td>Datum / date</td></tr> </table>				JefL	Revision 03	2020-12-16	JefL	Revision 02	2020-04-08	JefL	Revision 01	2019-11-26	Name	Änderung / modification	Datum / date
JefL	Revision 03	2020-12-16															
JefL	Revision 02	2020-04-08															
JefL	Revision 01	2019-11-26															
Name	Änderung / modification	Datum / date															

Würth Elektronik eiSos GmbH & Co.KG

D-74638 Waldenburg · Max-Eyth-Straße 1 - 3 · Germany · Telefon (+49) (0) 7942 - 945 - 0 · Telefax (+49) (0) 7942 - 945 - 400
<http://www.we-online.com>