



Application Tooling > Spare & Wear Tooling



Applicator & Product Style: OCEAN

Features

Other

Applicator & Product Style	OCEAN
----------------------------	-------

Product Compliance

[For compliance documentation, visit the product page on TE.com>](#)

EU RoHS Directive 2011/65/EU	Compliant
EU ELV Directive 2000/53/EC	Out of Scope
China RoHS 2 Directive MIIT Order No 32, 2016	No Restricted Materials Above Threshold
EU REACH Regulation (EC) No. 1907/2006	Current ECHA Candidate List: JAN 2021 (211) Candidate List Declared Against: JAN 2020 (205) SVHC > Threshold: Not Yet Reviewed
Halogen Content	Low Halogen - Br, Cl, F, I < 900 ppm per homogenous material. Also BFR/CFR/PVC Free
Solder Process Capability	Not applicable for solder process capability

Product Compliance Disclaimer

This information is provided based on reasonable inquiry of our suppliers and represents our current actual knowledge based on the information they provided. This information is subject to change. The part numbers that TE has identified as EU RoHS compliant have a maximum concentration of 0.1% by weight in homogenous materials for lead, hexavalent chromium, mercury, PBB, PBDE, DBP, BBP, DEHP, DIBP, and 0.01% for cadmium, or qualify for an exemption to these limits as defined in the Annexes of Directive 2011/65/EU (RoHS2). Finished electrical and electronic equipment products will be CE marked as required by Directive 2011/65/EU. Components may not be CE marked. Additionally, the part numbers that TE has identified as EU ELV compliant have a maximum concentration of 0.1% by weight in homogenous materials for lead, hexavalent chromium, and mercury, and 0.01% for cadmium, or qualify for an exemption to these limits as defined in the Annexes of Directive 2000/53/EC (ELV). Regarding the REACH Regulation, the information TE provides on SVHC in articles for this part number is based on the latest European Chemicals Agency (ECHA) 'Guidance on requirements for substances in articles' posted at this URL: <https://echa.europa.eu/guidance-documents/guidance-on-reach>

Compatible Parts



TE Part # 466981-1
SCAM5PR042F055O

Customers Also Bought



TE Part #31887
PIDG RING TONGUE TERMINALS



TE Part #327583
PIDG STEPDOWN BUTT SPLICES



TE Part #102387-9
40 MODIV HSG COMP DR .100 POL

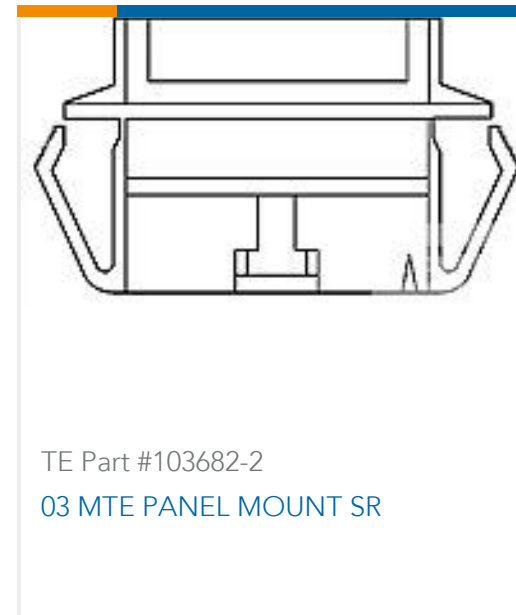

TE Part #103682-2
03 MTE PANEL MOUNT SR



TE Part #1658690-1
D-Sub Crimp Recpt Signal 15 Posn,
Socket Size 22, Shell Size 1

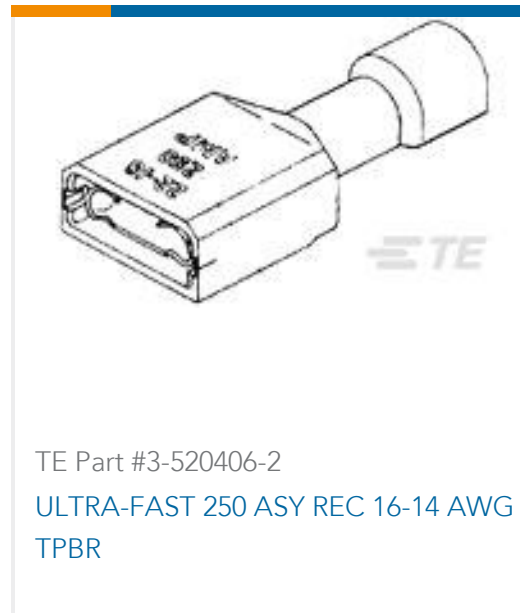

TE Part #3-520406-2
ULTRA-FAST 250 ASY REC 16-14 AWG
TPBR



TE Part #217885-6
CRIMPER, WIRE "F"



TE Part #NB13264001
RNF-100-3/4-BK-FSP

Documents

Datasheets & Catalog Pages

[CRIMPING WHERE FORM MEETS FUNCTION](#)

English

Instruction Sheets

[Instruction Sheet \(U.S.\)](#)

English