

ebm-papst Ventilator(Xi'an) Co.,Ltd  
 No.2555,No.5 Weishui Road,Weibei Industry Park,  
 Lintong District,Xi' an, Shaanxi Province,P.R.China  
 Tel:029-81366199

### Nominal data

Type	M4Q045-CA25-F3		
Motor	M4Q045-CA25		
Phase		1~	1~
Nominal voltage	VAC	230	230
Frequency	Hz	50	60
Method of obtaining data		me	me
Valid for approval/standard			
Speed (rpm)	min <sup>-1</sup>	1300	1550
Power consumption	W	36	34
Power output	W	10	9
Current draw	A	0.25	0.22
Min. ambient temperature	°C	-30	-30
Max. ambient temperature	°C	40	40

ml = Max. load · me = Max. efficiency · fa = Running at free air · cs = Customer specification · cu = Customer unit subject to alterations.

### Technical description

Weight	1.1 kg
Motor size	45
Bearing shield material	Die-cast aluminum
Direction of rotation	Counterclockwise, viewed toward rotor
Degree of protection	IP42
Insulation class	"B"
Moisture (F) / Environmental (H) protection class	H1
Max. permitted ambient temp. for motor (transport/storage)	+ 80 °C
Min. permitted ambient temp. for motor (transport/storage)	- 40 °C
Installation position	Shaft horizontal
Condensation drainage holes	None
Mode	S1
Motor bearing	Calotte bearing
Touch current according to IEC 60990 (measuring circuit Fig. 4, TN system)	< 0.75 mA
Motor protection	Impedance protection
With cable	Lateral
Protection class	I (with customer connection of protective earth)
Conformity with standards	EN 60335-1;
Approval	CCC GB12350;EAC; UL 1004-2; CSA C22.2 No. 77

Product drawing

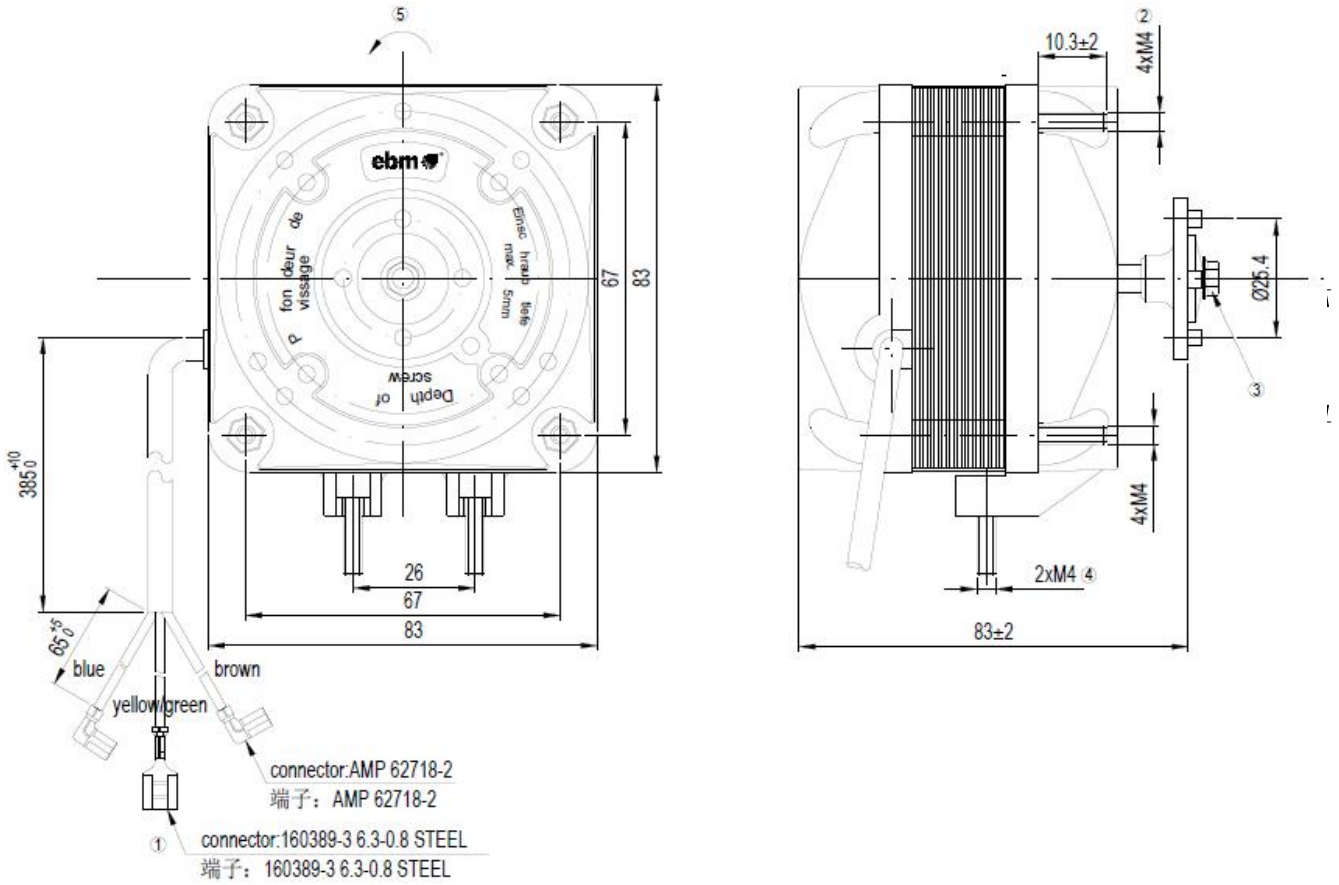

1	Cable PVC 3G AWG20, 3x connectors
2	Tightening torque for nut for fastening fan housing or guard grille 2.3 Nm
3	Tightening torque for screw for fastening fan impeller 1.4 Nm
4	Tightening torque for nut for fastening mounting bracket 2.3 Nm
5	Direction of rotation counterclockwise, viewed toward shaft end

Connection diagram

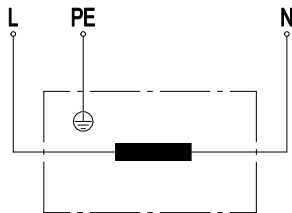

L	blue	PE	green/yellow	N	brown
---	------	----	--------------	---	-------

## Curves: Speed (rpm)

