

ebm-papst Mulfingen GmbH & Co. KG

Bachmühle 2 · D-74673 Mulfingen

Phone +49 7938 81-0

Fax +49 7938 81-110

info1@de.ebmpapst.com

www.ebmpapst.com

Limited partnership · Headquarters Mulfingen

Amtsgericht (court of registration) Stuttgart · HRA 590344

General partner Elektrobau Mulfingen GmbH · Headquarters Mulfingen

Amtsgericht (court of registration) Stuttgart · HRB 590142

Nominal data

Type	M4Q045-DA13-E4		
Motor	M4Q045-DA		
Phase		1~	1~
Nominal voltage	VAC	115	115
Frequency	Hz	50	60
Valid for approval/standard		CE	CE
Speed (rpm)	min ⁻¹	1300	1550
Power consumption	W	86	80
Power output	W	23	25
Current draw	A	1.25	1.1
Min. ambient temperature	°C	-30	-30
Max. ambient temperature	°C	40	40
Starting current	A	1.8	1.7

ml = Max. load · me = Max. efficiency · fa = Free air · cs = Customer specification · ce = Customer equipment
Subject to change



Technical description

Weight	1.54 kg
Motor size	45
Bearing shield material	Die-cast aluminum
Direction of rotation	Counterclockwise, viewed toward rotor
Degree of protection	IP42
Insulation class	"B"
Moisture (F) / Environmental (H) protection class	H1
Max. permitted ambient temp. for motor (transport/storage)	+ 80 °C
Min. permitted ambient temp. for motor (transport/storage)	- 40 °C
Installation position	Any, preferably horizontal
Condensation drainage holes	None
Mode	S1
Motor bearing	Calotte bearing
Touch current according to IEC 60990 (measuring circuit Fig. 4, TN system)	< 0.75 mA
Motor protection	Thermal overload protector (TOP) internally connected
With cable	Lateral
Protection class	I (with customer connection of protective earth)
Conformity with standards	EN 60335-1; CE
Approval	UL 1004-3; CSA C22.2 No. 77

Product drawing

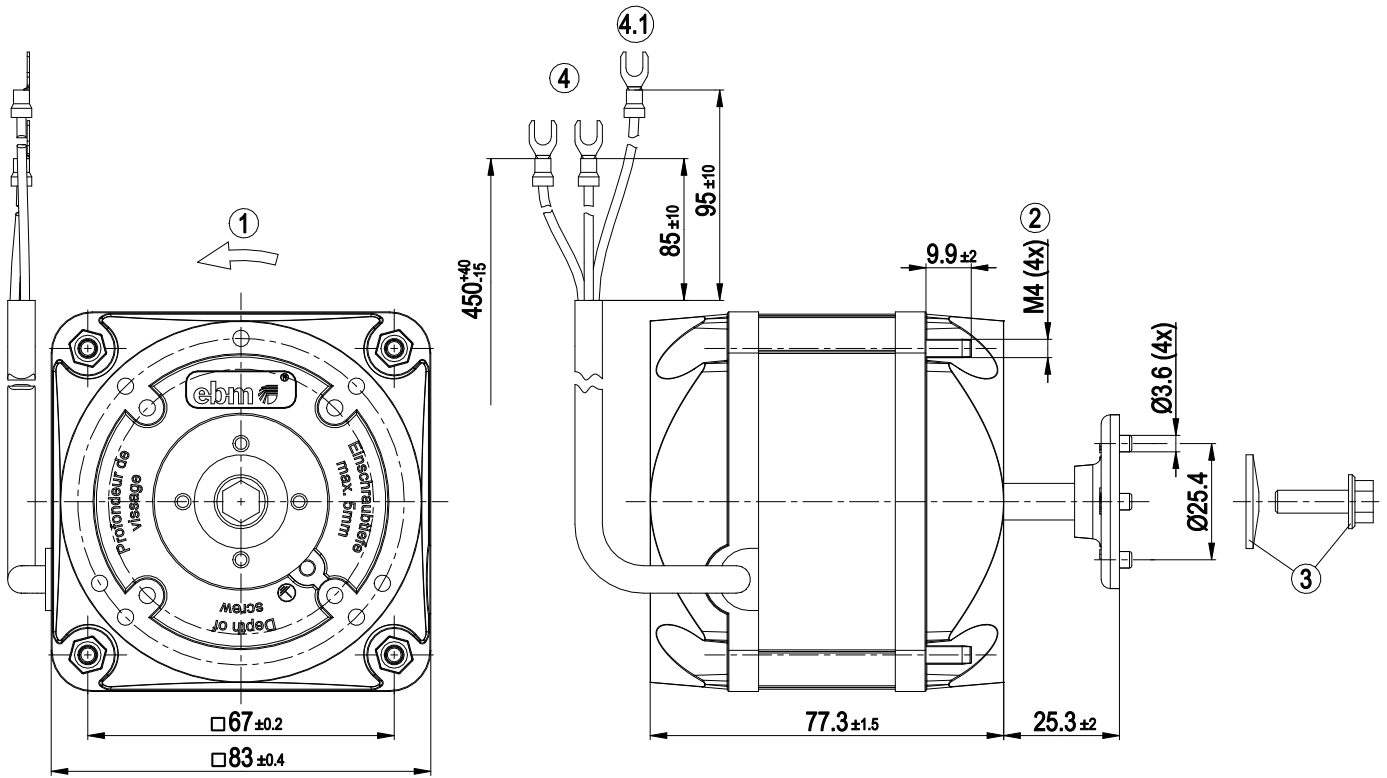

1	Direction of rotation counterclockwise, viewed toward shaft end
2	Tightening torque for nut for fastening fan housing or guard grill 2.3 Nm
3	Screw and spring washer included separately
	Tightening torque for screw to fasten fan impeller: 1.4 Nm
4	Cable PVC AWG20
	3x spade terminal Inarca 0010879201
4.1	green/yellow (PE)

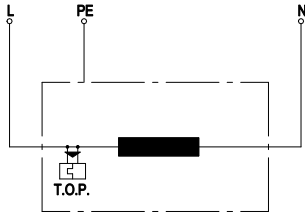

Connection diagram

L	= blue
PE	= green/yellow
N	= brown
TOP	= thermal overload protector

Curves: Speed (rpm)

