

swissbit®

Product Data Sheet

Industrial CFast™ Card

F-50 Series

SATA Gen3 – 6.0 Gbit/s, MLC

Commercial and Industrial
Temperature Grade

Date: December 17, 2019
Revision: 1.09



Contents

1. PRODUCT SUMMARY	3
2. PRODUCT FEATURES	4
3. ORDERING INFORMATION	5
4. PRODUCT DESCRIPTION	6
4.1 PERFORMANCE SPECIFICATIONS	7
4.2 CURRENT CONSUMPTION	7
4.3 ENVIRONMENTAL SPECIFICATIONS	8
4.4 REGULATORY COMPLIANCE	9
4.5 MECHANICAL SPECIFICATIONS	9
4.6 RELIABILITY AND ENDURANCE	10
4.7 DRIVE GEOMETRY SPECIFICATION	10
5. ELECTRICAL INTERFACE	11
6. PACKAGE MECHANICAL	12
7. ATA COMMANDS	13
8. IDENTIFY DEVICE DATA	15
9. S.M.A.R.T. FUNCTIONALITY	16
9.1 S.M.A.R.T. SUBCOMMANDS	16
9.2 S.M.A.R.T. READ DATA	17
9.3 S.M.A.R.T. ATTRIBUTES	17
9.4 S.M.A.R.T. ATTRIBUTE ENTRY STRUCTURE	18
10. PART NUMBER DECODER	19
10.1 MANUFACTURER	19
10.2 MEMORY TYPE	19
10.3 PRODUCT TYPE	19
10.4 DENSITY	19
10.5 PLATFORM	19
10.6 PRODUCT GENERATION	19
10.7 MEMORY ORGANIZATION	19
10.8 TECHNOLOGY	19
10.9 NUMBER OF FLASH CHIPS	19
10.10 FLASH CODE	19
10.11 TEMPERATURE OPTION	20
10.12 DIE CLASSIFICATION	20
10.13 PIN MODE	20
10.14 DRIVE CONFIGURATION XYZ	20
10.15 OPTION	20
11. SWISSBIT CFAST SSD MARKING SPECIFICATION	21
11.1 TOP VIEW	21
11.2 BOTTOM VIEW	21
11.3 LABEL CONTENT	21
12. REVISION HISTORY	22

F-50 Series – Industrial CFast™ Solid State Drive

8 GBytes up to 256 GBytes

1. Product Summary

- **Capacities:** 8 GBytes, 16 GBytes, 32 GBytes, 64 GBytes, 128 GBytes, 256 GBytes
- **Form Factor:** CFast-Sized Solid State Drive (36.4 mm x 42.8 mm x 3.6 mm)
- **Compliance:** SATA Gen3 – 6 Gbit/s (Gen2 – 3 Gbit/s and Gen1 – 1.5 Gbit/s backward compatible)
- **CFast 2.0 Compatible¹**
- **Command Sets:** Supports ATA/ATAPI-8 and ACS-2
- **Performance:**
 - Burst Transfer Rate: Up to 600 MBytes/s in SATA Gen3 – 6.0 Gbit/s
 - Read Performance: Sequential Read up to 500 MBytes/s, Random Read 4K up to 53,500 IOPS
 - Write Performance: Sequential Write up to 330 MBytes/s, Random Write 4K up to 74,000 IOPS
- **Operating Temperature Range²:**
 - Commercial: 0 °C to 70 °C
 - Industrial: -40 °C to 85 °C
- **Storage Temperature Range:** -40 °C to 85 °C
- **Operating Voltage:** 3.3 V ± 5%
- **Power (Max Capacity):**
 - Read (Active): 1.2 W
 - Write (Active): 2.0 W
 - Idle: 248 mW
 - Slumber: 17 mW
- **Data Retention:** 10 Years @ Life Begin; 1 Year @ Life End
- **Endurance:** TeraBytes Written (TBW) @ Max Capacity³
 - Client ≥ 165
 - Enterprise ≥ 8
- **Shock/Vibration:** 500 *g* / 20 *g*
- **High-Performance 32-Bit Processor with Integrated, Parallel Flash Interface Engines:**
 - Multi-Level Cell (MLC) NAND Flash
 - Hardware BCH Code ECC (up to 66 bit correction per 1 KByte page)
- **High Reliability:**
 - Mean Time Between Failure (MTBF): > 2,000,000 hours
 - Data Reliability: < 1 non-recoverable error per 10¹⁶ bits read

¹ Devices are CFast 2.0 compatible when in removable mode. Devices in removable mode are available upon request.

² Adequate airflow is required to ensure the temperature, as reported in the S.M.A.R.T. data, does not exceed 120°C (industrial temperature drive) and 105°C (commercial temperature drive) respectively.

³ According to JEDEC (JESD471), the time to write the full TBW is a minimum of 18 months. Higher average daily data volume reduces the specified TBW. The values listed are estimates and are subject to change without notice.

2. Product Features

- Dynamic and Static Wear Leveling
- Subpage Mode Flash Translation Layer (FTL)
- Active Data Care Management: Read Refresh
- Lifetime Enhancements
 - Dynamic Bad Block Remapping
 - Write Amplification Reduction
- On-Board Power Fail Protection
- AHCI, TRIM, and NCQ Support
- ATA Security Feature Set Support
- DEVSLP Compatible
- In-Field Firmware Update
- Enterprise-Grade Self-Monitoring, Analysis, and Reporting Technology (S.M.A.R.T.)
- Life Cycle Management
- Controlled "Locked" BOM
- RoHS-6 Compliant
- 30 µinch Gold-Plated Connector (on request)
- Conformal coating (on request)
- Swissbit Life Time Monitoring (SBLTM) Tool and SDK for SBLTM (on request)



3. Ordering Information

Table 1: Standard Product List

Capacity	Part Number
8 GBytes	SFCA008GHxAD1T0-t-GS-2y6-STD
16 GBytes	SFCA016GHxAD2T0-t-GS-2y6-STD
32 GBytes	SFCA032GHxAD4T0-t-GS-2y6-STD
64 GBytes	SFCA064GHxAD4T0-t-GS-2y6-STD
128 GBytes	SFCA128GHxAD4T0-t-LT-2y6-STD
256 GBytes	SFCA256GHxAD4T0-t-HT-2y6-STD

x = product generation; t = temperature; y= firmware revision

Table 2: Part Numbers Available for Ordering

Capacity	Commercial Temperature	Industrial Temperature
	Part Number	Part Number
8 GBytes	SFCA008GH2AD1T0-C-GS-236-STD	SFCA008GH2AD1T0-I-GS-236-STD
16 GBytes	SFCA016GH2AD2T0-C-GS-236-STD	SFCA016GH2AD2T0-I-GS-236-STD
32 GBytes	SFCA032GH2AD4T0-C-GS-236-STD	SFCA032GH2AD4T0-I-GS-236-STD
64 GBytes	SFCA064GH2AD4T0-C-GS-236-STD	SFCA064GH2AD4T0-I-GS-236-STD
128 GBytes	SFCA128GH2AD4T0-C-LT-236-STD	SFCA128GH2AD4T0-I-LT-236-STD
256 GBytes	SFCA256GH2AD4T0-C-HT-236-STD	SFCA256GH2AD4T0-I-HT-236-STD

4. Product Description

The Swissbit® F-50 Solid State Drive (SSD) leverages the CFast 2.0 compatible, industry-standard form factor and connectivity. Combined with a SATA Gen3 controller and Multi-Level Cell (MLC) NAND flash technology, the F-50 realizes a robust non-volatile storage solution for today's embedded storage applications. A functional block diagram of the F-50 SSD is provided below in Figure 1.

Figure 1: F-50 CFast Functional Block Diagram

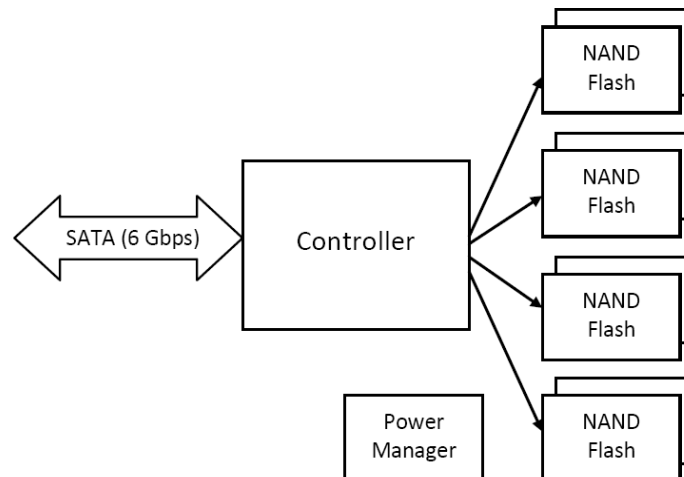

The F-50 SSD incorporates two existing industry standards into a single product: the CompactFlash™ (CF) card form factor and the Serial ATA (SATA) interface commonly used with hard disk drives (HDDs) and SSDs. The interface consists of a female 7-pin SATA data connector and a female 17-pin power connector. Because standard SATA hard drives use male connectors, an adaptor is required to replace drives with CFast cards. CFast cards can be used to replace HDDs, SSDs, and Compact Flash™ cards in applications requiring smaller form factors, high endurance, and the ability to withstand shock, vibration, extreme temperatures (-40°C to 85°C), high altitude, and rough environmental conditions. The Swissbit CFast™ cards provide rugged storage for embedded and industrial systems where data and system reliability, power fail protection, and flexibility are important design considerations.

The on-board SATA Gen3 controller manages the interface between the host and the non-volatile NAND flash memory array. The controller supports SATA Gen3 (6 Gbit/s) interface speeds and is fully backward compatible with SATA Gen2 (3 Gbit/s) and SATA Gen1 (1.5 Gbit/s) to enable the broadest possible range of platform compatibility. The controller utilizes an ARC 700 processing core, providing an optimum balance between read/write performance, Data Care Management, and power fail protection.

The F-50 achieves high sequential and random read/write performance (see Table 3: Read/Write Performance). In addition, the F-50 series feature Swissbit's proven power fail safety and support for the ATA security feature set, NCQ, TRIM, advanced wear leveling and bad block management, and in-field firmware updates.

An on-controller BCH Error Correction Code (ECC) engine provides the F-50 hardware ECC, which is capable of correcting up to 66 bits per 1 KByte page. This, combined with Swissbit's Data Care Management firmware, provides active data management strategies to ensure data integrity and extract the maximum possible endurance and reliability from the NAND flash array. These strategies include, but are not limited to, Global Wear Leveling, Read Refresh and Dynamic Block Remapping.

The risk of data loss as a result of an unexpected power fail event is mitigated using a robust sequence of voltage regulators and detectors designed to ensure a graceful shutdown of the controller and NAND flash array. A combination of both hardware and firmware power fail features prevent the possibility of resident data being corrupted during an unexpected power failure.

Related Documentation

- CFast Specification 2.0 (<http://www.compactflash.org>)
- Serial ATA International Organization Serial ATA Revision 3.0 (<http://www.serialata.org>)
- Serial Transport Protocols and Physical Interconnect (ATA/ATAPI-8) (<http://www.t13.org>)
- Electronic Industries Alliance (<http://www.ecianow.org>)

4.1 Performance Specifications

The F-50 read/write sequential and random I/O performance benchmarks are detailed below in Table 3.

Table 3: Read/Write Performance⁴

Capacity	Sequential Read (MBPS)	Sequential Write (MBPS)	Random Read 4K (IOPS)	Random Write 4K (IOPS)
8 GBytes	140	30	9,000	7,000
16 GBytes	280	55	18,000	14,000
32 GBytes	495	115	36,000	27,500
64 GBytes	500	100	36,000	24,500
128 GBytes	500	195	53,500	48,000
256 GBytes	500	330	53,500	74,000

4.2 Current Consumption

The drive-level current consumption as a function of operating mode is shown below in Table 4.

Table 4: Current Consumption⁵

Drive Capacity	Sequential Read	Sequential Write	Random Read	Random Write	Idle	Slumber	Unit
8 GBytes	175	170	160	165	75	5	mA
16 GBytes	235	210	195	210	75	5	
32 GBytes	325	280	250	275	75	5	
64 GBytes	325	285	250	280	75	5	
128 GBytes	335	420	255	415	75	5	
256 GBytes	350	615	230	575	75	5	

⁴ The values are measured using Crystal Disk Mark (CDM) across the full drive density. Performance depends on flash type and number, file/cluster size, and burst speed.

⁵ All values are the maximum recorded running IOMeter script for Read/Write operations with 1MB transfer size in 1 minute intervals at 25 °C, with nominal supply voltage and SATA transfer rate 6Gb/s.

4.3 Environmental Specifications

4.3.1 Recommended Operating Conditions

The recommended operating conditions for the F-50 SSDs are provided in Table 5 below.

Table 5: Recommended Operating Conditions⁶

Parameter	Value
Commercial Operating Temperature	0 °C to 70 °C
Industrial Operating Temperature	-40 °C to 85 °C
Power Supply V _{CC} Voltage	3.3 V ± 5%

4.3.2 Recommended Storage Conditions

The recommended storage conditions are listed below in Table 6.

Table 6: Recommended Storage Conditions

Parameter	Value
Commercial Storage Temperature	-40 °C to 85 °C
Industrial Storage Temperature	-40 °C to 85 °C

4.3.3 Shock, Vibration and Humidity

The maximum shock, vibration and humidity conditions are listed below in Table 7.

Table 7: Shock, Vibration and Humidity

Parameter	Value
Non-Operating Shock	500 g acceleration, 1ms pulse duration, half-sine wave (IEC 60068-2-27 and JESD22-B104 cond. A)
Non-Operating Vibration	20 g acceleration, 80-2,000 Hz, 3 axes, 12 cycles (IEC 60068-2-6, MIL-STD-883 H Method 2007.3)
Humidity (Non-Condensing)	85% RH 85 °C, 1000 hrs, max. supply voltage (JESD22-A101B)

⁶ Adequate airflow is required to ensure the temperature, as reported in the S.M.A.R.T. data, does not exceed 120°C (industrial temperature drive) and 105°C (commercial temperature drive) respectively.

4.4 Regulatory Compliance

The F-50 devices comply with the standards listed in the following table.

Table 8: Regulatory Compliance

Compliance	Country	Type	Standard(s)/Directive
CE	European Union	Certificate	2011/65/EU, 2012/19/EU, 2014/30/EU
CE/EMC	European Union	Compliance	2004/108/EC (AS/NZS CISPR22 :2009 +A1:2010, EN 61000-6-2:2005/AC:2005, EN 61000-6-4:2007/A1:2011 [EN55022:2010 Class B])
CE/RoHS	European Union	Compliance	2011/65/EU
CE/WEEE	European Union	Compliance	2012/19/EU
REACH	European Union	Certificate	1907/2006
FCC	United States	Certificate	47CFR Part 15, Class B
UL	United States	Compliance	UL/CSA 60950-1, Second Edition
VCCI	Japan	Compliance	ITE (Class A)
CCC	China	Compliance	Laws and Regulations of the People's Republic of China Governing Foreign-Related Matters (1991.7)
C-Tick	Australia	Compliance	AS/NZS CISPR22
TüV	Germany	Compliance	TüV IEC 60950-1; UL/CSA 60950-1, Second Edition
SATA-IO	International	Compliance	SATA Revision 1.4 Interoperability

4.5 Mechanical Specifications

The F-50 SSD consists of a flash controller and NAND flash memory devices. The controller interfaces with a host system allowing data to be written to and read from the flash memory array. The SSD has a female 7-pin SATA data connector and a female 17-pin power connector. Because standard SATA hard drives use male connectors, an adaptor is required to replace drives with CFast cards. Physical dimensions are detailed in Table 9 below. Figure 3 on page 12 illustrates the F-50 dimensions and connector location.

Table 9: Physical Dimensions

Physical Dimensions		Unit
Length	36.40±0.15	mm
Width	42.80±0.10	
Thickness (Max)	3.60	
Weight (Max Capacity)	10	g

4.6 Reliability and Endurance

The Mean Time Between Failure (MTBF) is specified to exceed the value listed below. Data reliability with effective error tolerance and data retention at the beginning and end of life is also provided.

Table 10: Reliability

Parameter	Value
MTBF (at 25 °C)	> 2,000,000 hours
Data Reliability	< 1 Non-Recoverable Error per 10 ¹⁶ Bits Read
Data Retention	10 Years at Start (JESD47), 1 Year at EOL

Endurance represented as both TeraBytes Written (TBW) and full Drive Writes Per Day (DWPD) for two different application scenarios is provided in the following table.

Table 11: Endurance⁷

Drive Capacity	Client ⁸		Enterprise	
	TBW	DWPD ⁹	TBW	DWPD ⁹
8 GBytes	10.78	1.23	0.66	0.075
16 GBytes	28.16	1.61	1.72	0.098
32 GBytes	45.76	1.31	2.79	0.080
64 GBytes	76.05	1.09	4.54	0.065
128 GBytes	105.61	0.75	7.81	0.056
256 GBytes	169.05	0.60	8.30	0.030

NOTE: Because NAND flash has a limited life, replace the drive once it has reached the number of program/erase (P/E) cycles rated for the device as data loss can occur at any time beyond this point. The current and rated erase counts for the device are reported in the S.M.A.R.T. data. Swissbit also offers lifetime monitoring software and a software development kit (SDK) to monitor drive health.

4.7 Drive Geometry Specification

The F-50 drive geometry is set to report industry standard LBA settings per the IDEMA standard (LBA1-03). The values for each capacity are shown below in Table 12.

Table 12: Drive Geometry

Drive Capacity	User Capacity ¹⁰	Total LBA	User Addressable Bytes
		Decimal	(Unformatted)
8 GBytes	8 GBytes	15,649,200	8,012,390,400
16 GBytes	16 GBytes	31,277,232	16,013,942,784
32 GBytes	32 GBytes	62,533,296	32,017,047,552
64 GBytes	64 GBytes	125,045,424	64,023,257,088
128 GBytes	128 GBytes	250,069,680	128,035,676,160
256 GBytes	256 GBytes	500,118,192	256,060,514,304

⁷ Client and Enterprise workloads follow the JEDEC JESD219 standard. Enterprise workload values are measured based on 168 hours of runtime. 1 TByte = 10¹² bytes

⁸ Because the JEDEC master trace file for the Client workload is designed for capacities ≥ 60 GBytes, the TBW and DWPD values for the capacities below 60 GBytes are estimates.

⁹ DWPD values are based on a service life of 3 years

¹⁰ 1 GByte = 10⁹ bytes

5. Electrical Interface

The CFast card is connected with a standard 7-pin SATA connector and a standard 17-pin power connector (see below Figure 2: F-50 CFast Connector). The signal/pin assignments and descriptions are listed in Table 13.

Figure 2: F-50 CFast Connector

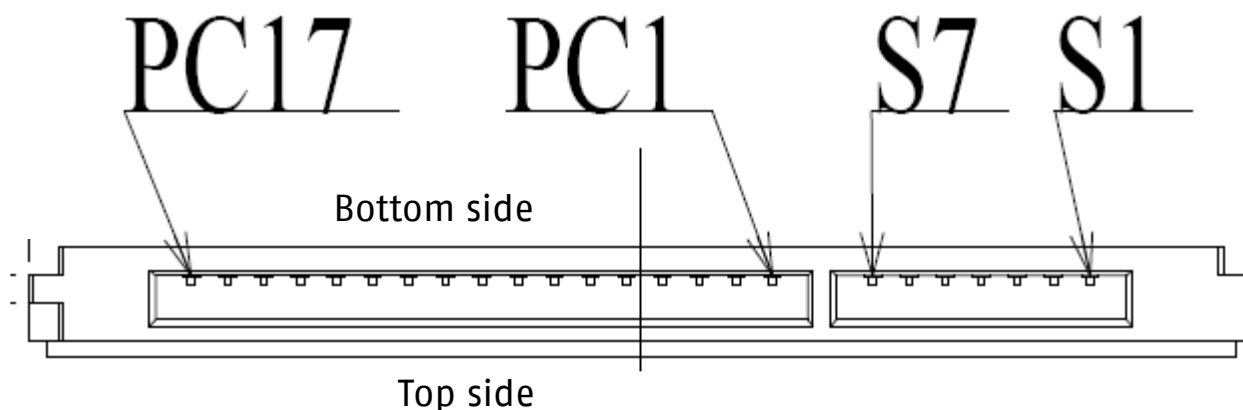

Table 13: Pin Assignment, Name, and Description

Pin	Signal Name	Description
S1	SGround	Signal Ground
S2	A+	+ Differential Device Transmit Signal
S3	A-	- Differential Device Transmit Signal
S4	SGround	Signal Ground
S5	B-	- Differential Device Receive Signal
S6	B+	+ Differential Device Receive Signal
S7	SGround	Signal Ground
PC1	CDI ¹¹	Card Detect In
PC2	PGround	Power Ground
PC3	DEVSLP	DEVSLP Input
PC4-PC6	NC	No Connect
PC7	PGround	Power Ground
PC8	LED1	Reserved
PC9	LED2	Reserved
PC10-PC11		Reserved
PC12	IFDet	Card Output, Connected to GND
PC13-PC14	3.3 V	Device Power 3.3 V
PC15-PC16	PGround	Power Ground
PC17	CDO ¹¹	Card Detect Out

¹¹ CDI and CDO are physically shorted together in the device. The CDO logic state shall follow the CDI logic state whether the device is powered up or not.

6. Package Mechanical

NOTE: The dimensions in the following figure are the maximum values based on the CFast specification. For the product dimensions, see the *Mechanical Specifications* section on page 9.

Figure 3: CFast SSD Dimensions in mm [in]

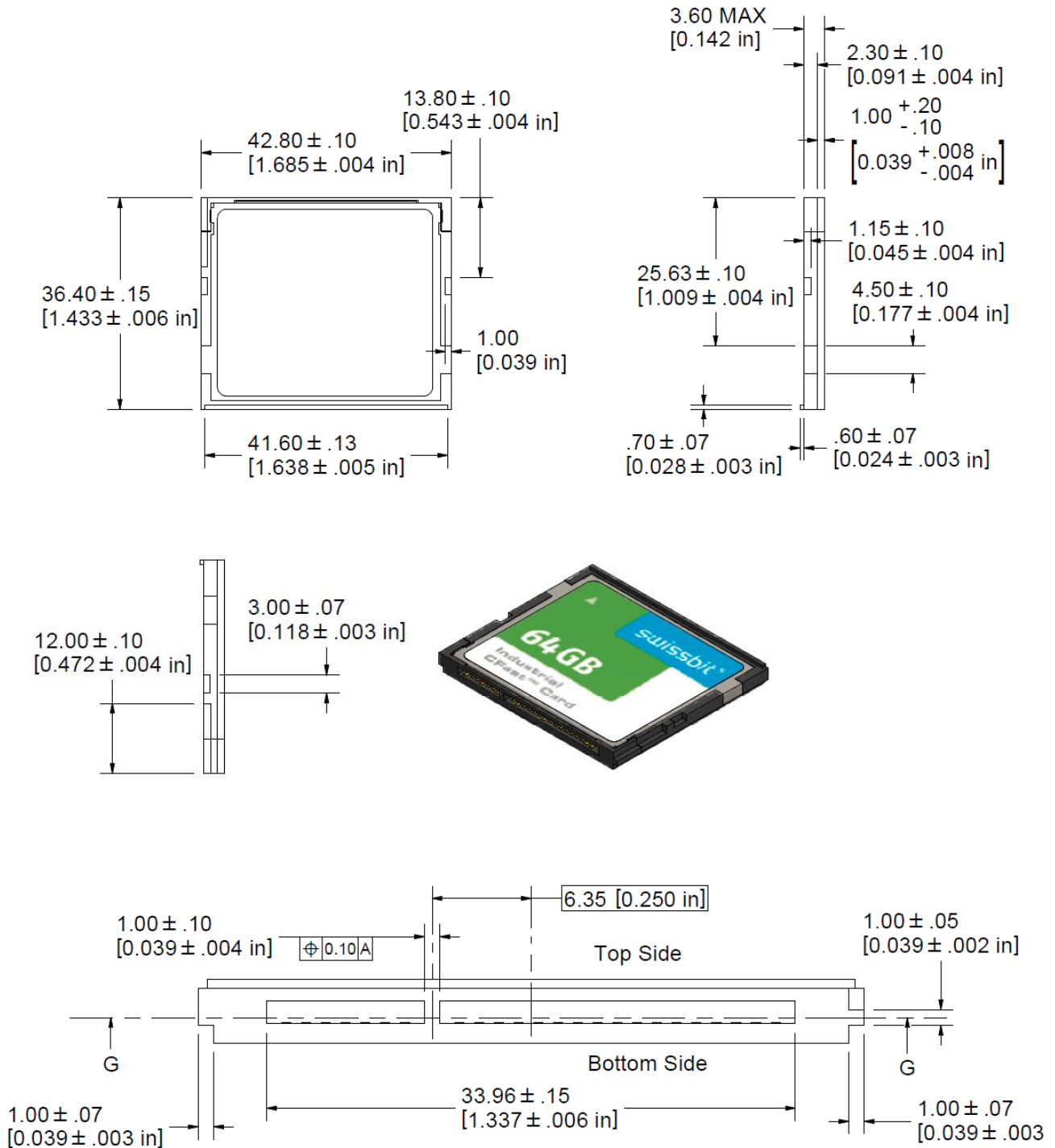

7. ATA Commands

This section provides information on the ATA commands supported by the SSD. The commands are issued to the ATA by loading the required registers in the command block with the supplied parameter, and then writing the command code to the register. For backward compatibility, some commands are implemented as a "no operation". See Table 14 for a list of ATA commands the device supports. For details about setting up the command registers, see the latest ATA Specification.

Table 14: ATA Command Set

Command	Code	Protocol
General Feature Set		
Execute Device Diagnostic	90h	Execute Device Diagnostic
Flush Cache	E7h	Non-data
Identify Device	Ech	PIO data-in
Initialize Drive Parameters	91h	Non-data
Read DMA	C8h	DMA
Read Log Ext	2Fh	PIO data-in
Read Multiple	C4h	PIO data-in
Read Sector(s)	20h	PIO data-in
Read Verify Sector(s)	40h or 41h	Non-data
Set Feature	Efh	Non-data
Set Multiple Mode	C6h	Non-data
Write DMA	Ca9h	DMA
Write Multiple	C5h	PIO data-out
Write Sector(s)	30h	PIO data-out
NOP	00h	Non-data
Read Buffer	E4h	PIO data-in
Write Buffer	E8h	PIO data-out
Power Management Feature Set		
Check Power Mode	E5h or 98h	Non-data
Idle	E3h or 97h	Non-data
Idle Immediate	E1h or 95h	Non-data
Sleep	E6h or 99h	Non-data
Standby	E2h or 96h	Non-data
Standby Immediate	E0h or 94h	Non-data
Security Mode Feature Set		
Security Set Password	F1h	PIO data-out
Security Unlock	F2h	PIO data-out
Security Erase Prepare	F3h	Non-data
Security Erase Unit	F4h	PIO data-out
Security Freeze Lock	F5h	Non-data
Security Disable Password	F6h	PIO data-out
S.M.A.R.T. Feature Set		
S.M.A.R.T. Disable Operations	Boh	Non-data
S.M.A.R.T. Enable/Disable Autosave	Boh	Non-data
S.M.A.R.T. Enable Operations	Boh	Non-data
S.M.A.R.T. Execute Off-Line Immediate	Boh	Non-data
S.M.A.R.T. Read Data	Boh	PIO data-in
S.M.A.R.T. Read Log	Boh	PIO data-in
S.M.A.R.T. Read Threshold	Boh	PIO data-in
S.M.A.R.T. Return Status	Boh	Non-data
S.M.A.R.T. Save Attribute Values	Boh	Non-data
S.M.A.R.T. Write Log	Boh	PIO data-out

Command	Code	Protocol
Host Protected Area Feature Set		
Read Native Max Address	F8h	Non-data
Set Max Address	F9h	Non-data
Set Max Set Password	F9h	PIO data-out
Set Max Lock	F9h	Non-data
Set Max Freeze Lock	F9h	Non-data
Set Max Unlock	F9h	PIO data-out
48-Bit Address Feature Set		
Flush Cache Ext	Eah	Non-data
Read Sector(s) Ext	24h	PIO data-in
Read DMA Ext	25h	DMA
Read Multiple Ext	29h	PIO data-in
Read Native Max Address Ext	27h	Non-data
Read Verify Sector(s) Ext	42h	Non-data
Set Max Address Ext	37h	Non-data
Write DMA Ext	35h	DMA
Write DMA FUA Ext	3Dh	DMA
Write Multiple Ext	39h	PIO data-out
Write Multiple FUA Ext	Ceh	PIO data-out
Write Sector(s) Ext	34h	PIO data-out
NCQ Feature Set		
Read FPDMA Queued	60h	DMA Queued
Write FPDMA Queued	61h	DMA Queued
Others		
Data Set Management	06h	DMA
Seek	70h	Non-data

8. Identify Device Data

The following table describes the 512 bytes of data the drive returns for the Identify Device command (ECh).

Table 15: Identify Device Information

Word(s)	Default Value	Total Bytes	Data Field Type Information
0	044Ah*	2	Standard Configuration Fixed (optional 848Ah for removable)
1	XXXXh	2	Default number of cylinders
2	0000h	2	Reserved
3	00XXh	2	Default number of heads
4-5	0000h	4	Obsolete
6	XXXXh	2	Default number of sectors per track
7-8	XXXXh	4	Number of sectors per drive (Word 7 = MSW, Word 8 = LSW)
9	0000h	2	Obsolete
10-19	aaaa	20	Serial number in ASCII (right-justified)
20-22	0000h	6	Obsolete
23-26	XXXX*	8	Firmware revision in ASCII (big-endian byte order in Word)
27-46	XXXX*	40	Model number in ASCII (right-justified)
47	8001h	2	Maximum number of sectors on Read/Write Multiple command
48	4000h	2	Trusted Computing feature set not supported
49	2F00h*	2	Standby Timer, DMA, LBA, IORDY supported
50	4000h	2	Capabilities
51	0200h	2	PIO data transfer cycle timing mode
52	0000h	2	Obsolete
53	0007h*	2	Words 88 and 64-70 valid
54	XXXXh	2	Current numbers of cylinders
55	XXXXh	2	Current numbers of heads
56	XXXXh	2	Current sectors per track
57-58	XXXXh	4	Current capacity in LBAs (Word 57 = LSW, Word 58 = MSW)
59	010Xh*	2	Multiple sector setting (host changeable)
60-61	XXXXh	4	Total number of sectors addressable in LBA mode
62	0000h	2	Obsolete
63	0007h* 0000h*	2	Multiword DMA transfer support modes 2, 1, and 0 Multiword DMA not supported
64	0003h	2	Advanced PIO modes supported
65	0078h*	2	Minimum Multiword DMA transfer cycle time per Word
66	0078h*	2	Recommended Multiword DMA transfer cycle time
67	0078h*	2	Minimum PIO transfer cycle time without flow control
68	0078h*	2	Minimum PIO transfer cycle time with IORDY flow control
69	0100h	2	CFast support
70-74	0000h	10	Reserved
75	001Fh	1	Queue Depth
76	870Eh	2	SATA Capabilities
77	0086h	2	Additional SATA Capabilities
78	014Ch	2	SATA feature support
79	0040h*	2	SATA features enabled (host changeable)
80	03FCh	2	Major revision
81	0000h	2	Minor revision
82 -84	746Bh* 7D09h* 4163h*	6	Features/command sets supported
85-87	7429h* 7429h* 4163h*	6	Features/command sets enabled (may change in operation)
88	407Fh*	2	UDMA mode supported
89	0001h*	2	Time for security erase unit completion
90	0001h*	4	Time for enhanced security erase completion
91	0000h	2	Power Management
92	FFFEh*	2	Master password revision code

Word(s)	Default Value	Total Bytes	Data Field Type Information
93-99	0000h*	14	Reserved
100-103	XXXXh	8	Max user LBA48 address feature set
104-105	0000h	4	Reserved
106	4000h	2	Sector size
107-118	0000h	24	Reserved
119-120	4018h 4018h	4	Command set supported settings Command set features enabled
121-127	0000h	14	Reserved
128	0021h*	2	Security status (may change in operation)
129-159	XXXXh	62	"Swissbit SSD"
160	0000h*	2	Power requirement
161	0000h	2	CFast Configuration
162	0000h	2	Management schemes
163	0000h	2	IDE Timing
164	0000h	2	IO Timing
165-168	0000h	8	Reserved
169	0001h	2	Data Set Management supported
170-208	XXXXh	78	Reserved
209	4000h	2	Logical block alignment
210-216	0000h	14	Reserved
217	0001h*	2	Nominal media rotation rate: Solid State Device
218-221	0000h	8	Reserved
222	107Fh	2	Transport major revision
223-233	0000h	22	Reserved
234	0020h	2	Minimum number of 512-byte units per segmented download
235	0020h	2	Maximum number of 512-byte units per segmented download
236-254	0000h	38	Reserved
255	XXXXh	2	Integrity Word

* Standard values for full functionality are listed. Values depend on device configuration.

9. S.M.A.R.T. Functionality

The F-50 SSD fully supports the ATA Specification for Self-Monitoring, Analysis, and Reporting Technology (S.M.A.R.T.).

9.1 S.M.A.R.T. Subcommands

The following table lists the supported S.M.A.R.T. subcommands and the Features register values.

Table 16: S.M.A.R.T. Features Supported

Features	Operation
D0h	S.M.A.R.T. Read Data
D1h	S.M.A.R.T. Read Attribute Thresholds
D2h	S.M.A.R.T. Enable/Disable Autosave
D3h	S.M.A.R.T. Save Attribute Values
D4h	S.M.A.R.T. Execute Off-Line Immediate
D5h	S.M.A.R.T. Read Log
D6h	S.M.A.R.T. Write Log
D8h	S.M.A.R.T. Enable Operations
D9h	S.M.A.R.T. Disable Operations
DAh	S.M.A.R.T. Return Status

The device aborts any S.M.A.R.T. subcommands with Features register values not listed in the above table.

9.2 S.M.A.R.T. Read Data

When the drive receives the S.M.A.R.T. Read Data subcommand, it returns one sector (512 bytes) of data. See the following table for the data structure of this sector.

Table 17: S.M.A.R.T. Data Structure

Byte(s)	Value	Description
0-1	0100h	S.M.A.R.T. structure version
2-361	XXh	Attribute entries 1 to 30 (see Table 19)
362	00h	Off-line data collection status (no off-line data collection started)
363	00h	Self-test execution status byte (self-test completed)
364-365	0000h	Total time, in seconds, to complete off-line data collection
366	00h	Vendor specific
367	00h	Off-line data collection capability (no off-line data collection)
368-369	0002h	S.M.A.R.T. capabilities
370	01h	Error logging capability
371	00h	Vendor specific
372	01h	Short self-test routine recommended polling time, in minutes
373	01h	Extended self-test routine recommended polling time, in minutes
374	01h	Conveyance self-test routine recommended polling time, in minutes
375-385	00h	Reserved
386-395	XXh	Firmware version in ASCII
396-399	00h	Reserved
400-405	XXh	Controller model in ASCII ("SM2246XT")
406-510	00h	Reserved
511	XXh	Data structure checksum

9.3 S.M.A.R.T. Attributes

The F-50 drives support the S.M.A.R.T. attributes listed in the following table.

Table 18: S.M.A.R.T. Attributes

ID	Worst	Threshold	Attribute	Description
01h	100	0	Raw Read Error Rate	Total number of Cyclic Redundancy Check (CRC) errors that occurred over the SATA interface
05h	100	0	Reallocated Sector Count	Total number of runtime identified (field marked) bad blocks
09h	100	0	Power-On Hours	Total hours that the device has been powered on and operational (not in Sleep mode)
0Ch	100	0	Power Cycle Count	Total number of power cycles that have occurred during the life of the drive
A0h	100	0	Uncorrectable Sector Count	Total number of sectors read (active or passive) with UECC errors
A1h	100	0	Spare Block Count	Total number of spare blocks currently available
A2h	100	0	Number of Cache Data Blocks	Status of the cache data block (0 = inactive; 1 = active)
A3h	100	0	Number of Initial Invalid Blocks	Total number of initially identified (factory marked and pretest) bad blocks
A4h	100	0	Total Erase Count	Total number of erase operations that have ever been performed on all currently valid blocks (excluding the system, bad and reserved blocks)
A5h	100	0	Maximum Erase Count	The maximum number of erase operations that have ever been performed on a single block (excluding the system, bad and reserved blocks)
A6h	100	0	Minimum Erase Count	The minimum number of erase operations that have ever been performed on a single block (excluding the system, bad and reserved blocks)
A7h	100	0	Average Erase Count	The average number of erase operations that have ever been performed on a single block (excluding the system, bad and reserved blocks)

ID	Worst	Threshold	Attribute	Description
A8h	100	0	Maximum Specified Erase Count	The specified maximum erase count; equivalent to number of program/erase (P/E) cycles rated for the device
A9h	100	0	SSD Remaining Life	Percent of SSD life remaining on the SSD (a value from 0 to 64h), normalized to 100; based upon Average Erase Count (A7h) scaled by the Maximum Specified Erase Count (A8h)
C0h	100	0	Power Off Retract Count	Total number of unexpected power-off events that occurred
C2h	100	0	Current Temperature	Current temperature of the device
C3h	100	0	Flash ECC Recovered	Total number of times the read-retry process was required to recover data
C4h	100	0	Reallocation Event Count	Total count of remapping operations
C7h	100	0	CRC Error Count	Total count of cyclic redundancy check (CRC) errors that occurred over the SATA interface
F1h	100	0	Total Host LBAs Written	The total number of LBAs written to the device by the host; each increment represents 32 MBytes of writes
F2h	100	0	Total Host LBAs Read	The total number of LBAs read from the device by the host; each increment represents 32 MBytes of reads
F5h	100	0	Total Flash LBAs Written	The total number of LBAs written to the flash; this value represents the number of 32 MByte flash transfers

9.4 S.M.A.R.T. Attribute Entry Structure

Each attribute entry consists of 12 bytes. See the following table for the data structure of each entry.

Table 19: Attribute Entry

Byte(s)	Value	Description
0	XXh	Attribute ID (see Table 18)
1-2	XXXXh	Flags (little-endian)
3	XXh	Attribute value as a percentage
4	XXh	Worst value as a percentage
5-8	XXXXh	Raw value (little-endian)
9-11	00h	Reserved

10. Part Number Decoder

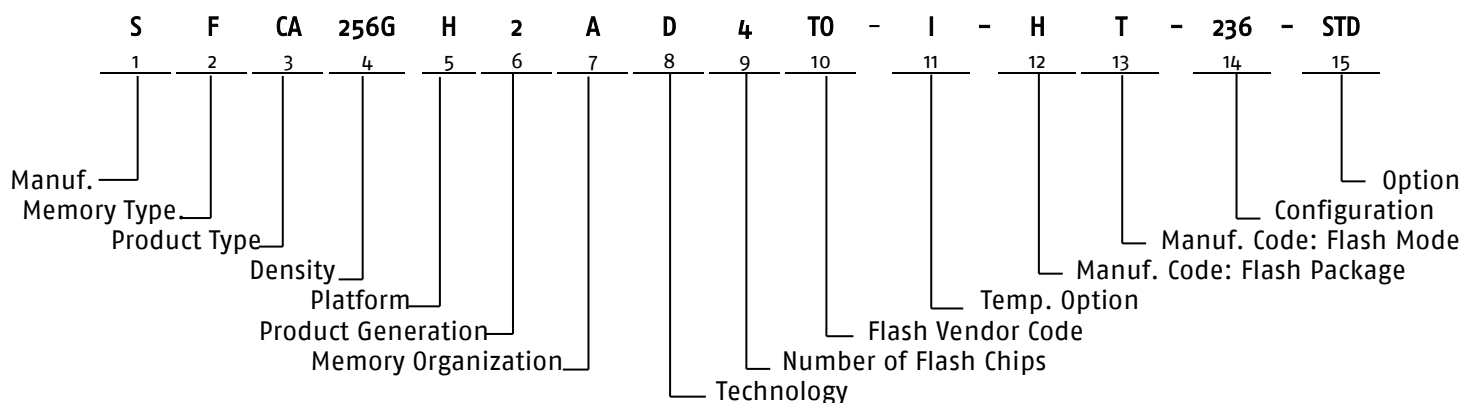

10.1 Manufacturer

Swissbit code	S
---------------	---

10.2 Memory Type

Flash	F
-------	---

10.3 Product Type

CFast Interface	CA
-----------------	----

10.4 Density

8 GBytes	008G
16 GBytes	016G
32 GBytes	032G
64 GBytes	064G
128 GBytes	128G
256 GBytes	256G

10.5 Platform

CFast SSD	H
-----------	---

10.6 Product Generation

10.7 Memory Organization

x8	A
----	---

10.8 Technology

F-50 Series	D
-------------	---

10.9 Number of Flash Chips

1 Flash	1
2 Flash	2
4 Flash	4

10.10 Flash Code

Toshiba	T0
---------	----

10.11 Temperature Option

Industrial Temperature Range: -40 °C to 85 °C	I
Commercial Temperature Range: 0 °C to 70 °C	C

10.12 Die Classification

MLC MONO (single die package)	G
MLC DDP (dual die package)	L
MLC QDP (quad die package)	H
MLC ODP (octal die package)	O

10.13 Pin Mode

	TSOP	BGA
Single nCE and Single R/nB	S	A
Dual nCE and Dual R/nB	T	B
Quad nCE and Quad R/nB	U	C
Octal nCE and Octal R/nB	*	V
Sexdec nCE & Sexdec R/nB	*	W

*Not Available

10.14 Drive Configuration XYZ

X = Type

Drive Mode	PIO	DMA Support	X
Fix	Yes	Yes	2

Y = Firmware Revision

FW Revision	Y
SBS10058	3

Z = Feature

Feature	Z
Standard	6

10.15 Option

Swissbit/Standard	STD
-------------------	-----

11. Swissbit CFast SSD Marking Specification

11.1 Top View



11.2 Bottom View



11.3 Label Content

- Swissbit Logo
- CFast Logo
- Part Number
- Lot Code information with Bar Code
- CE Logo
- RoHS Logo
- WEEE Logo
- Manufacturing Date
- Country of Origin

12. Revision History

Table 20: Document Revision History

Date	Revision	Description	Revision Details
7-Mar-2016	0.95	First preliminary release.	
9-Mar-2016	1.00	Initial release.	Doc. req. no. 1000
20-May-2016	1.01	Changed Endurance, performance, and consumption values. Identify device data Word 0 044Ah (fixed drive).	Doc. req. no. 1032
14-Jun-2016	1.02	Added regulatory table. Updated power consumption and performance values.	Doc. req. no. 1127
5-Jul-2016	1.03	Added note regarding P/E cycles for endurance.	Doc. req. no. 1157
27-Jul-2016	1.04	Changed firmware version.	Doc. req. no. 1190
31-Aug-2016	1.05	Fixed typo.	Doc. req. no. 1250
4-Nov-2016	1.06	Added SSD Remaining Life attribute (A9h), updated mechanical drawing, and fixed typo.	Doc. req. no. 1353
05-Dec-2018	1.07	Updated product features and description, product picture, firmware info (chapters device info and S.M.A.R.T. read data), endurance values, test-conditions and part-number decoder (pin mode)	Doc. req. no. 2659
28-Feb-2018	1.08	Updated product description and sections to meet standard datasheet review criteria.	Doc. req. no. 2790
17-Dec-2019	1.09	Updated ordering information and sections to meet standard datasheet review criteria. Updated endurance.	Doc. req. no. 3347

Disclaimer:

No part of this document may be copied or reproduced in any form or by any means, or transferred to any third party, without the prior written consent of an authorized representative of Swissbit AG ("SWISSBIT"). The information in this document is subject to change without notice. SWISSBIT assumes no responsibility for any errors or omissions that may appear in this document, and disclaims responsibility for any consequences resulting from the use of the information set forth herein. SWISSBIT makes no commitments to update or to keep current information contained in this document. The products listed in this document are not suitable for use in applications such as, but not limited to, aircraft control systems, aerospace equipment, submarine cables, nuclear reactor control systems and life support systems. Moreover, SWISSBIT does not recommend or approve the use of any of its products in life support devices or systems or in any application where failure could result in injury or death. If a customer wishes to use SWISSBIT products in applications not intended by SWISSBIT, said customer must contact an authorized SWISSBIT representative to determine SWISSBIT willingness to support a given application. The information set forth in this document does not convey any license under the copyrights, patent rights, trademarks or other intellectual property rights claimed and owned by SWISSBIT. The information set forth in this document is considered to be "Proprietary" and "Confidential" property owned by SWISSBIT.

ALL PRODUCTS SOLD BY SWISSBIT ARE COVERED BY THE PROVISIONS APPEARING IN SWISSBIT'S TERMS AND CONDITIONS OF SALE ONLY, INCLUDING THE LIMITATIONS OF LIABILITY, WARRANTY AND INFRINGEMENT PROVISIONS. SWISSBIT MAKES NO WARRANTIES OF ANY KIND, EXPRESS, STATUTORY, IMPLIED OR OTHERWISE, REGARDING INFORMATION SET FORTH HEREIN OR REGARDING THE FREEDOM OF THE DESCRIBED PRODUCTS FROM INTELLECTUAL PROPERTY INFRINGEMENT, AND EXPRESSLY DISCLAIMS ANY SUCH WARRANTIES INCLUDING WITHOUT LIMITATION ANY EXPRESS, STATUTORY OR IMPLIED WARRANTIES OF MERCHANTABILITY OR FITNESS FOR A PARTICULAR PURPOSE.

©2019 SWISSBIT AG All rights reserved.