

# TEMPATRON

## TT33 Digital Multifunction Timer User Manual



Tempatron: Eltime House, Hall Road, Maldon, Essex, CM9 4NF UK.

Telephone: +44(0)1621 859500 Email: sales@tempatron.co.uk Web: www.tempatron.co.uk



Please read this document carefully before using this product. The product guarantee will become invalidated by any damage to the timer caused by not following the instructions in the user manual. Tempatron do not accept any liability for personal injury, material damage or capital losses which may arise by not following the instructions in the user manual.

- 4 digit red LED display panel mounting digital timer
- 5 programmable timing modes
- Time ranges from 0-99.99sec to 0-9999hrs
- 24Vac/dc or 100-240Vac powered
- 1 changeover and 1 N/O relay output
- Programmable reset function
- Easy to programme through front keys
- Status and timing indicators
- Selectable up/down timing
- EEPROM memory (minimum 10 years)
- Security passcode
- IP65 enclosure



**TECHNICAL SPECIFICATION**

**ENVIRONMENTAL CONDITIONS**

Operating/Storage Temperature: 0°C to +50°C / -20°C to +60°C  
 Protection Class: IP65  
 Maximum Installation Height: 2000m

Do not use this timer in locations where corrosive or flammable gases could be present.

**ELECTRICAL**

Power Supply Voltage: 24Vac/dc or 100-240Vac  
 Power Consumption (Burden): <3VA  
 Frequency: 50/60Hz  
 Wiring: 2mm<sup>2</sup> screw type terminals  
 Data Retention: EEPROM (minimum 10 years)  
 CE Markings: **Directive LV 2014/35/EU** (EN 60730-1, EN 60730-2-7, EN 61812-1, UL 508)  
**Directive EMC 2014/30/EU** (EN 55011: class B; EN 61000-4-2, EN 61000-4-3, EN 61000-4-4, EN 61000-4-5, EN 61000-4-6)

**OUTPUTS**

Relay Outputs (R1 & R2): Out1: Single pole changeover contact 16A rated at 240Vac (resistive load)  
 Out2: Single pole N/O contact 5A rated at 240Vac (resistive load)  
 Relay Contact Life: Mechanical 1,000,000 operations  
 Electrical 100,000 operations  
 Reset Time: 100ms approx.  
 Accuracy: ±3sec/24hours

**HOUSING**

Housing Type: Panel mounting  
 Display: 4 digit red LED display  
 Dimensions: 78mm wide x 35mm high x 64mm deep  
 Weight: Approximately 130g (without packaging)  
 Enclosure Materials: Self extinguishing plastics, UL 94 V0

When cleaning the timer, solvents (thinners, gasoline, acid etc.) or corrosive materials must not be used.

**WIRING CONNECTIONS**

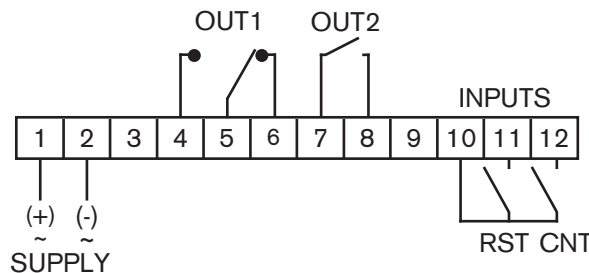

## FRONT PANEL DISPLAY FUNCTIONS

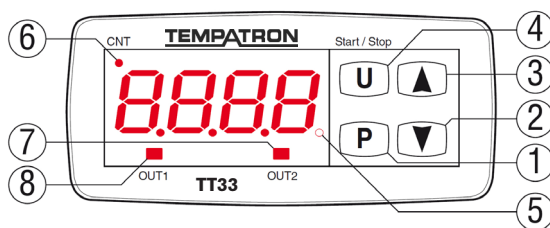

## KEYS & DISPLAY SYMBOLS

1. **P**: Press and release to set the time delays (if programmed with the  $t.E.d.t$  parameter). Press for 5 seconds to enter the programming mode. Press again to access the parameter edit mode and confirm the values. In programming mode press together with the **▲** key to change the programming level of the parameters. When the keys are locked press the **P** and **▲** keys together for 5 seconds to unlock the keys.
2. **▼**: When in programming mode, press to decrease the setting value and to select parameters.
3. **▲**: When in programming mode, press to increase the setting value and to select parameters. In programming mode press together with the **P** key to change the programming level of the parameters. Press together with the **P** key to unlock the keys.
4. **U Start/Stop**: Press for Start/Stop/Reset functions as programmed using the  $t.U.F$  parameter.
5. **SET LED**: In normal operating mode this indicates the time delays are being set. In programming mode this indicates the parameter programming level.
6. **CNT LED**: Indicates count in progress (flashes every 1 second), count interrupted (steadily on) or the reset status (off).
7. **OUT2 LED**: Indicates the status of output relay 2 (illuminated for ON and not illuminated for OFF).
8. **OUT1 LED**: Indicates the status of output relay 1 (illuminated for ON and not illuminated for OFF).

## DIMENSIONS

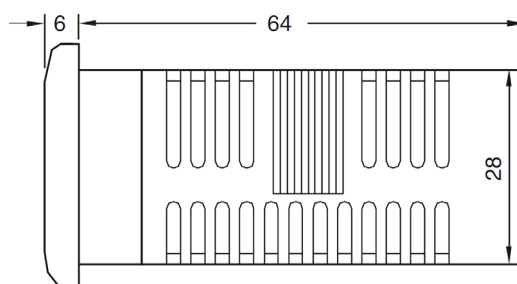
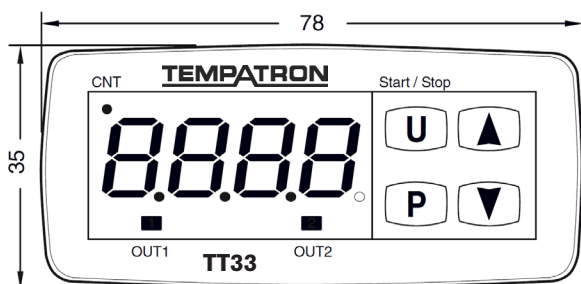

All dimensions in mm

## PANEL CUTOUT

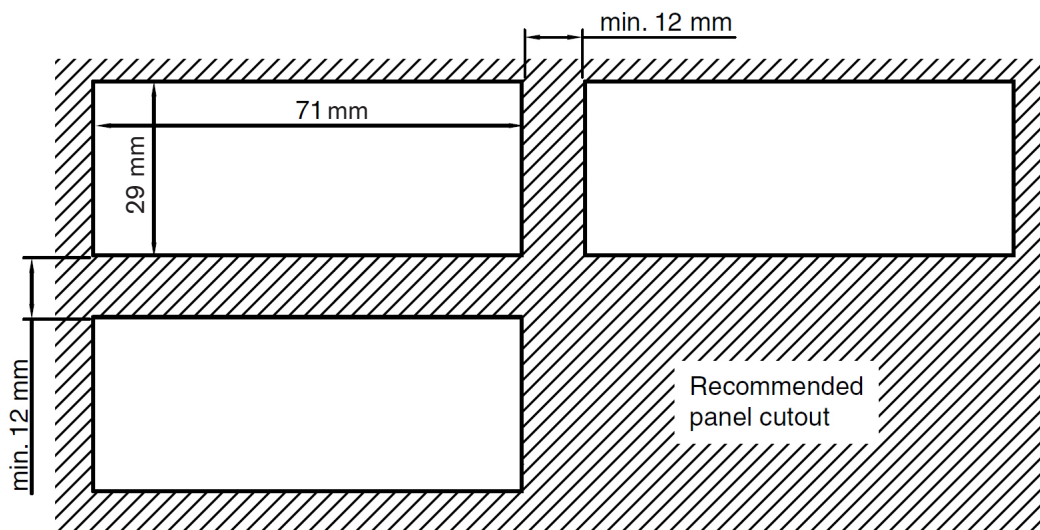

## SET TIME PROGRAMMING (FAST MODE)

1. To set the delay times (set times) press the **P** key, the **SET LED** will illuminate and the display will show  $S_{t1}$  (parameter acronym) and its programmed value. To change the value press the **▲** key to increase the value shown or the **▼** key to decrease it. Note: Press the **▲**/**▼** keys for longer than 1 second to increase/decrease the numerical value more quickly.

Through programming the  $tEdt$  parameter it is possible to select which set times can be set in this fast mode. An option also exists which allows the setting of the  $S_{t1}$  set time value only using the **▲**/**▼** keys without pressing the **P** key in advance ( $tEdt = 8$ ). The options for the  $tEdt$  parameter are as follows:

**oF** No set time can be set with the **P** short key (if pressed and released the **P** key has no effect).

- 1 Only  $S_{t1}$  set time value can be set with this procedure.
- 2 Only  $S_{t2}$  set time value can be set with this procedure.
- 3  $S_{t1}$  and  $S_{t2}$  set time values can be set with this procedure.
- 4 Only  $S_{t3}$  set time value can be set with this procedure.
- 5  $S_{t1}$  and  $S_{t3}$  set time values can be set with this procedure.
- 6  $S_{t2}$  and  $S_{t3}$  set time values can be set with this procedure.
- 7  $S_{t1}$ ,  $S_{t2}$  and  $S_{t3}$  set time values can be set with this procedure.
- 8  $S_{t1}$  set time value can be set directly with the **▲**/**▼** keys.

For example, when the **P** parameter is set to **1** or **3**, the procedure is as follows:

- Press and release the **▲** key, the display shows  $S_{t1}$  alternated with the  $S_{t1}$  value.
- To change the set time, press the **▲** key to increase the value or the **▼** key to decrease the value.
- If  $tEdt = 1$ , once the desired value has been set, press the **P** key to exit the set time programming mode.
- If  $tEdt = 3$ , pressing and releasing the **P** key the display shows  $S_{t2}$  alternating with the value. To change the value use the **▲**/**▼** keys using the same method as for the  $S_{t1}$  value.
- Once the set time(s) have been programmed, press the **P** key to exit the set time programming mode. If no key is pressed for over 10 seconds the display will automatically return to normal operation.

$S_{t1}$  and  $S_{t3}$  can be set within the limits established by parameters  $S_{L1}$  and  $S_{H1}$  and  $S_{t2}$  can be set within the limits established by  $S_{L2}$  and  $S_{H2}$ .

## PARAMETER SETTING MODE

To access the timer function parameters when passcode protection is disabled, press the **P** key for 5 seconds, after which the display shows the code that identifies the first programmable parameter. Use the **▲**/**▼** keys to select the desired parameter then press the **P** key, the display will then show the parameter code, alternated with its value, that can then be changed with the **▲**/**▼** keys. Once the desired value has been reached, press the **P** key again to store the new value, the display will then return to show the parameter code. Press the **▲**/**▼** keys to select any other desired parameters and change them using the same method. To exit the programming mode, press no key for 30 seconds or keep the **U** key pressed for 2 seconds. The timer display will then return to showing the timing count value.

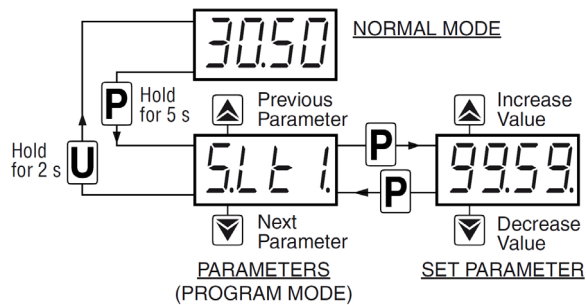

## PARAMETER PROTECTION USING A PASSCODE

The timer has a parameter protection function using a passcode that can be personalised through the  $tPP$  parameter. To protect the parameters, set the  $tPP$  parameter to your desired passcode number.

When the passcode protection is active, press the **P** key for 5 seconds after which the display shows  $r.P.$ . Press the **P** key and the display will show **0.**. Using the **▲**/**▼** keys, enter the programmed passcode number and press the **P** key again. If the passcode is correct the timer will display the code of the first programmable parameter and it is possible to program the timer as previously described.

The passcode protection can be disabled by setting  $tPP = oF$ .

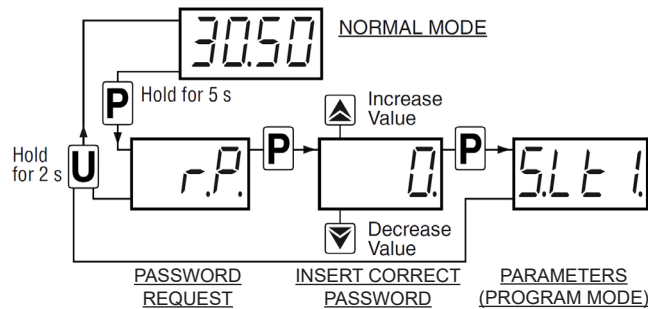

Notes:

1. All parameters are configured by default as protected so that by simply setting the  $tPP$  parameter they are all protected by the passcode.
2. If the passcode is lost, switch the timer OFF then ON, pushing the **P** key during initial test and keeping it pressed for 5 seconds. All programmable parameters are then accessible and parameter  $tPP$  can be set as required.

## CUSTOMISED PARAMETER PASSCODE PROTECTION

All parameters are configured by default as protected. To make certain parameters programmable without protection whilst keeping the protection on other parameters, the procedure is as follows:

- Enter program mode using the  $\text{L.P.P}$  passcode and with the  $\uparrow/\downarrow$  keys, select the parameter that must be accessible without passcode protection.
  - Once the parameter is selected, if the **SET LED flashes** the parameter is programmable only after entering the passcode (protected). If the **SET LED is steadily ON** the parameter is programmable without entering the passcode (unprotected).
  - To change the parameter protection, press the  $\text{P}$  key and keeping it pressed, also press the  $\uparrow$  key.
  - The **SET LED** changes its state indicating the new level of parameter protection (**ON** = unprotected, **Flashing** = passcode protected).
- If some parameters are set as unprotected, when accessing the programming mode the display first shows the unprotected parameters then the parameter  $\text{r.P}$  through which it will then be possible to access the protected parameters.

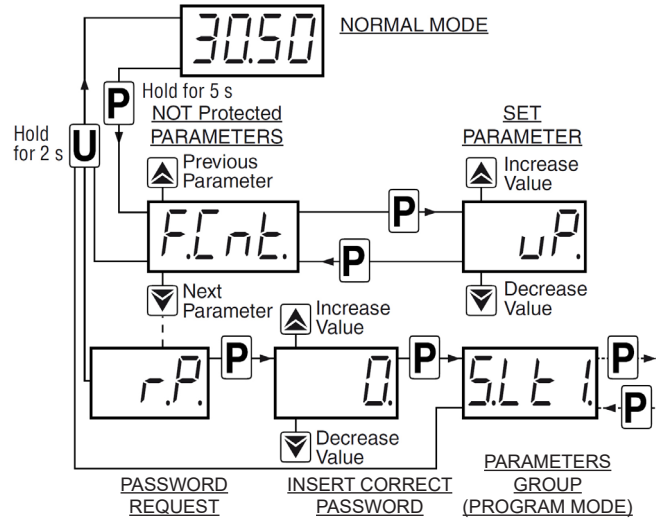

## RESET PARAMETERS TO DEFAULT VALUE

To reset all parameters to the factory default values enter  $-4B$  at the  $\text{r.P}$  passcode request. The passcode must first be enabled by setting parameter  $\text{L.P.P}$  so that the  $\text{r.P}$  setting is requested. Enter the  $-4B$  value and press the  $\text{P}$  key to confirm. The display shows “- - -” for 2 seconds and then all parameters have been reset to the factory default values.

## KEY LOCK FUNCTION

It is possible to completely lock the timer keys. This function is useful when the timer is being used in an accessible area and unauthorised changes must be avoided. To activate the key lock, program the parameter  $\text{L.L.O}$  to a value different from **oF**. The  $\text{L.L.O}$  value is the time in seconds of key inactivity after which the keys are automatically locked. When the keys are locked, if any of the keys are pressed the display shows  $\text{L.n}$  to indicate the key lock is active. To unlock the keys press the  $\text{P}$  key and  $\uparrow$  key together for 5 seconds,  $\text{L.F}$  will then appear on the display and all the key functions will be active again.

## INTERNAL BUZZER OPERATION

The internal buzzer can be programmed using the  $\text{F.b.u.F}$  parameter to operate as follows:

**oF** Internal buzzer disabled.

- 1 The internal buzzer operates at the end of  $\text{S.t.1}$  for  $\text{S.t.2}$  period. The buzzer also sounds when keys are pressed. If a **Reset** command is activated (by a key or digital input), the buzzer is silenced immediately. This buzzer mode is only active for timing operating modes that do not use the  $\text{S.t.2}$  time.
- 2 The internal buzzer operates at the end of  $\text{S.t.1}$  for  $\text{S.t.2}$  period. The buzzer does not sound when keys are pressed.
- 3 The buzzer only sounds when keys are pressed.
- 4 Only the external buzzer output is activated at the end of  $\text{S.t.1}$  for  $\text{S.t.2}$  period (if **OUT2** configured with  $\text{F.o.2.t} = 5$ ).

## COUNTING OPERATION MODES

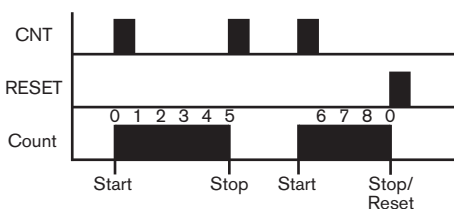

### $iF.c.t. = 1$ Bistable Start/Stop

Activating the **CNT** input starts the timer counting and the **CNT** input can then be deactivated. Activating the **CNT** input again stops the counting on the value reached (without disabling the output if this was activated). The next **CNT** impulse resumes the count from the point it stopped, and so on, until the end of the count or the **Reset** signal. In this mode the  $\text{U}$  Start/Stop key (if  $\text{L.U.F.t} = 2$ ) acts exactly the same way as the **CNT** input with the addition that, when pressed for 2 seconds during the counting, performs the **Reset** command. If the counting has finished, pressing the  $\text{U}$  key performs the **Reset-Start** command at the same time.

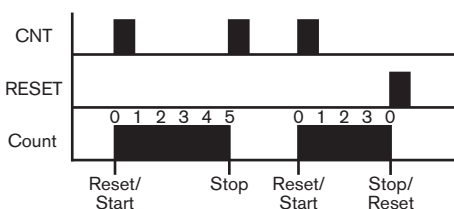

### $iF.c.t. = 2$ Bistable Reset-Start/Stop

Activating the **CNT** input resets and starts the timer counting and the **CNT** input can then be deactivated. Activating the **CNT** input again, if done before the end of the count, stops the count (disabling the output if this was activated). The next **CNT** impulse starts a new count cycle or if the second **CNT** impulse arrives after the end of the count, a new count cycle is started. In this mode the  $\text{U}$  Start/Stop key (if  $\text{L.U.F.t} = 2$ ) acts exactly the same way as the **CNT** input.

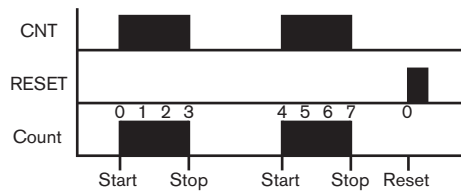

**$iF_{ct} = 3$  Monostable Start/Stop**

Activating the **CNT** input and keeping it active, starts the timer counting and the count then stops on the value reached when the **CNT** input is deactivated (without disabling the output if this was activated). The next **CNT** impulse resumes the count from the point it stopped, and so on, until the **Reset** signal. In this mode the **U** Start/Stop key (if  $LUFF =$  different to **oF**) only acts as a **Reset**.

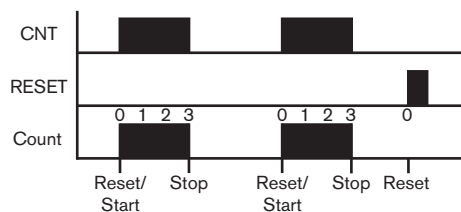

**$iF_{ct} = 4$  Monostable Reset-Start/Stop**

Activating the **CNT** input and keeping it active, resets and starts the timer counting and the count then stops on the value reached when the **CNT** input is deactivated (disabling the output if this was activated). This count operation mode is similar to a traditional timer in which the counting is enabled when the timer is powered and the **Reset** occurs when the power supply is removed. In this mode the **U** Start/Stop key (if  $LUFF =$  different to **oF**) only acts as a **Reset**.



**$iF_{ct} = 5$  Bistable Reset-Start/Stop**

Activating the **CNT** input **Resets** the timer. Activating the **CNT** input again starts the timer counting and activating the **CNT** input for a third time stops the count on the value reached (disabling the output if this was activated). In this mode the **U** Start/Stop key (if  $LUFF = 2$ ) acts exactly the same way as the **CNT** input.

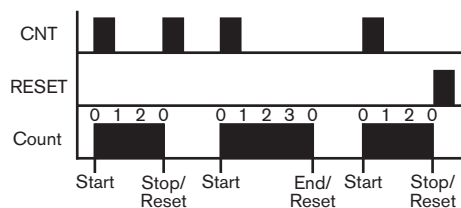

**$iF_{ct} = 6$  Bistable Start/Stop-Reset**

Activating the **CNT** input starts the timer counting and the **CNT** input can then be deactivated. Activating the **CNT** input again, if done before the end of the count, stops the count (disabling the output if this was activated) and **Resets** the count. If the second **CNT** impulse arrives after the end of the count, a new count cycle is started. In this mode the **U** Start/Stop key (if  $LUFF = 2$ ) at the end of  $S_{t1}$  time acts exactly the same way as the **CNT** input.

**OUT1 OPERATING MODES**

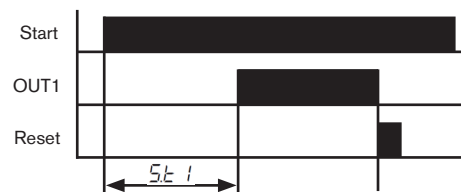

**$F.o It = 1$  Delay on Energise (On Delay)**

The timer starts counting when the **Start** signal is activated. At the end of the time period  $S_{t1}$ , the output relay **OUT1** energises and remains energised until the **Reset** signal is activated.

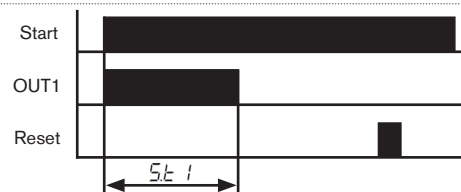

**$F.o It = 2$  Interval**

The timer starts counting and the output relay **OUT1** energises when the **Start** signal is activated. At the end of the time period  $S_{t1}$ , the output relay **OUT1** de-energises. The output can only be reactivated after a **Reset** signal and a new **Start** signal.

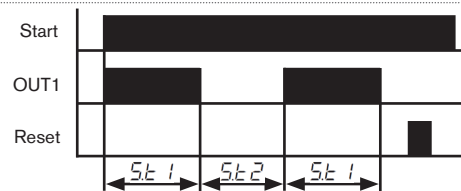

**$F.o It = 3$  Immediate Cycle with Variable On and Off Times**

The timer starts counting and the output relay **OUT1** energises when the **Start** signal is activated. At the end of the time period  $S_{t1}$ , the output relay **OUT1** de-energises and then after time period  $S_{t2}$  **OUT1** energises again and this repeats indefinitely until the **Stop/Reset** signal is activated.

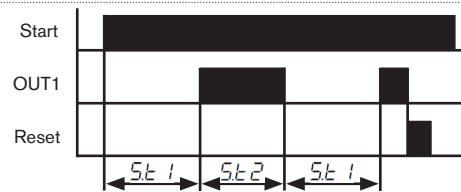

**$F.o It = 4$  Delayed Cycle with Variable On and Off Times**

The timer starts counting when the **Start** signal is activated. At the end of the time period  $S_{t1}$  the output relay **OUT1** energises and then after time period  $S_{t2}$  **OUT1** de-energises. After a further time period  $S_{t1}$  **OUT1** energises again and this repeats indefinitely until the **Stop/Reset** signal is activated.

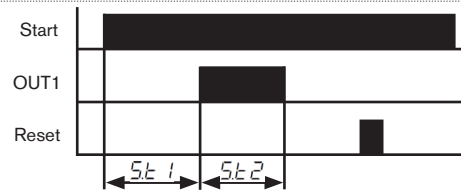

**$F.o It = 5$  Single Delayed Cycle with Variable On and Off Times**

The timer starts counting when the **Start** signal is activated. At the end of the time period  $S_{t1}$  the output relay **OUT1** energises and then after time period  $S_{t2}$  **OUT1** de-energises. The cycle can only be reactivated after a **Reset** signal and a new **Start** signal.

## OUT2 OPERATING MODES

The second output (**OUT2**) can be programmed in one of 5 different operating modes with the  $F_{o2t}$  parameter.

$F_{o2t} = 0$  **OUT2** disabled

$F_{o2t} = 1$  **OUT2** operates exactly the same as **OUT1** to give a double output contact

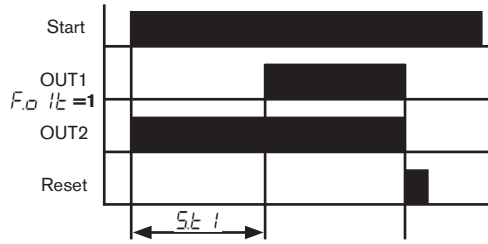

$F_{o2t} = 2$  **Instantaneous Contact**

**OUT2** is energised during the counting process and remains energised until the **Reset** signal is activated.

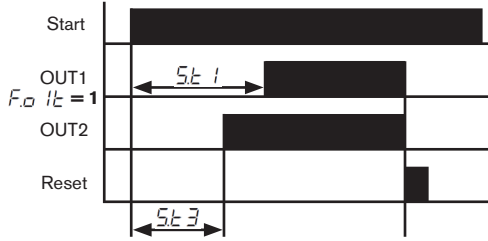

$F_{o2t} = 3$  **OUT2 Operates the same function as OUT1 but with S\_t3 time**

**OUT2** operates exactly the same function as **OUT1** but whilst **OUT1** operates to time  $S_{t1}$ , **OUT2** operates to time  $S_{t3}$ .  $S_{t3}$  has the same time range as  $S_{t1}$  (9999h, 99h59m, 99m59s or 99.99s) and cannot be set to a value higher than  $S_{t1}$ .

If  $F_{o1t} = 1, 4$  or  $5$ , **OUT2** operates a delay on energise function.

If  $F_{o1t} = 2$  or  $3$ , **OUT2** operates a feed through function with a  $S_{t3}$  set time.

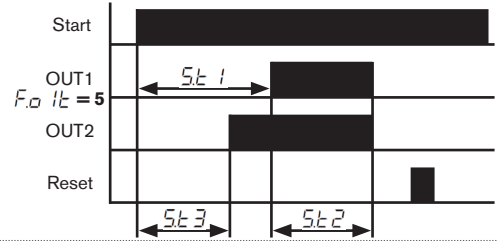
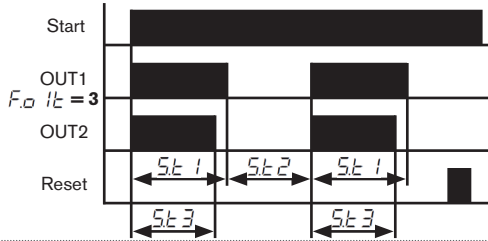
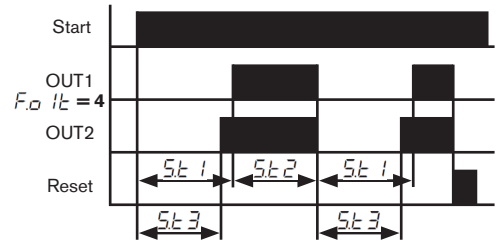
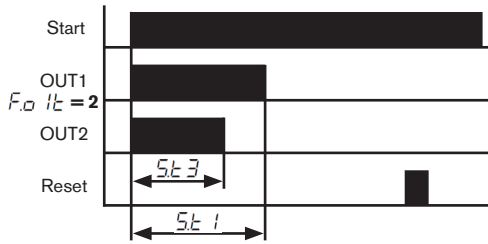

$F_{o2t} = 4$  **OUT2 Operates the same function as OUT1 but in advance by S\_t3 time**

**OUT2** operates exactly the same function as **OUT1** but **OUT2** operates  $S_{t3}$  in advance of **OUT1**.  $S_{t3}$  has the same time range as  $S_{t1}$  (9999h, 99h59m, 99m59s or 99.99s) and cannot be set to value higher than  $S_{t1}$ .

If  $F_{o1t} = 1, 4$  or  $5$ , **OUT2** operates a delay on energise function.

If  $F_{o1t} = 2$  or  $3$ , **OUT2** operates a feed through function with a  $S_{t3}$  set time.

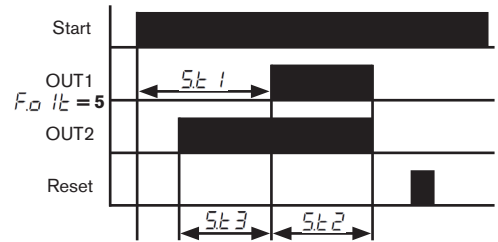
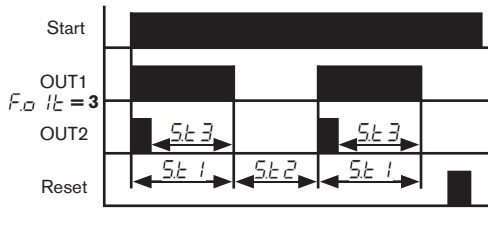
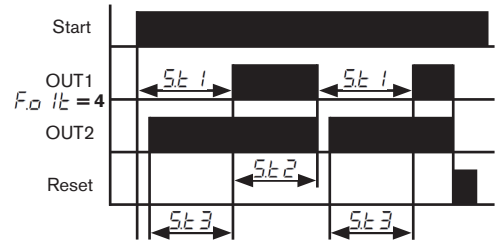
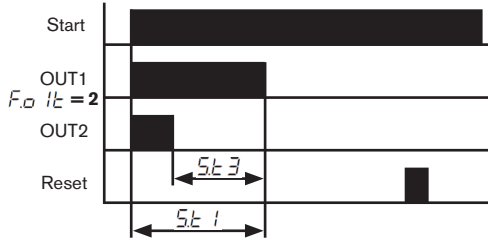
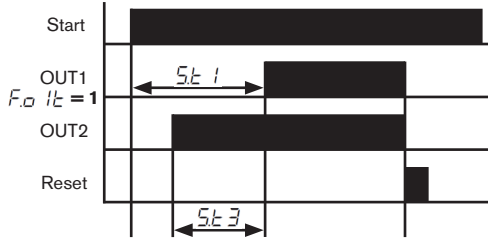





$F_{o2t} = 5$  **OUT2** energises when the buzzer sounds (with  $F_{buF} = 2$ ) to manage an external sound/light signalling device.

## OPERATION WITH A POWER SUPPLY INTERRUPTION

When the power supply to the timer is restored after an interruption the timing count can be programmed using the *F.buL* parameter to operate as follows:

- 1 The timing count resets.
- 2 The timing count stops at the value reached when the power supply ceased. The timing count continues once a new **Start** signal is activated.
- 3 The timing count stops at the value reached when the power supply ceased. When the power supply is restored the count restarts from that value if the conditions for restarting are present (e.g. the timer was counting within a bistable mode when the power supply ceased).

## PROGRAMMABLE PARAMETERS

	Parameter	Description	Range	Default	Note
1	<i>S.Lt 1</i>	<i>S.Lt 1</i> Minimum set time	0 to S.Ht1	0	
2	<i>S.Ht 1</i>	<i>S.Lt 1</i> Maximum set time	S.Lt1 to 9999	99.59	
3	<i>S.Lt 2</i>	<i>S.Lt 2</i> Minimum set time	0 to S.Ht2	0.00	
4	<i>S.Ht 2</i>	<i>S.Lt 2</i> Maximum set time	S.Lt2 to 9999	99.59	
5	<i>SSt 1</i>	<i>S.Lt 1</i> Time range	1 hours (9999h) 2 hours & minutes (99h 59min) 3 minutes & seconds (99min 59s) 4 seconds (99.99s)	3	
6	<i>SSt 2</i>	<i>S.Lt 2</i> Time range	1 hours (9999h) 2 hours & minutes (99h59min) 3 minutes & seconds (99min59s) 4 seconds (99.99s)	3	
7	<i>S.Lt 1</i>	<i>S.Lt 1</i> Set time	S.Lt1 to S.Ht1	1.00	
8	<i>S.Lt 2</i>	<i>S.Lt 2</i> Set time	S.Lt2 to S.Ht2	0.00	
9	<i>S.Lt 3</i>	<i>S.Lt 3</i> Set time	S.Lt1 to S.Ht1	0.00	
10	<i>iF.c.t</i>	CNT input operating mode	1 Bistable START/STOP 2 Bistable RESET-START/STOP 3 Monostable START/STOP 4 Monostable RESET-START/STOP 5 Bistable RESET/START/STOP 6 Bistable START/STOP-RESET	2	
11	<i>F.o.l.t</i>	OUT1 output operating mode	1 Delay on Energise (On Delay) 2 Interval 3 Immediate Cycle with Variable On and Off Times 4 Delayed Cycle with Variable On and Off Times 5 Single Delayed Cycle with Variable On and Off Times	1	
12	<i>F.o.2.t</i>	OUT2 output operating mode	oF OUT2 disabled 1 OUT2 operates exactly the same as OUT1 2 Instantaneous contact 3 OUT2 operates the same function as OUT1 but with <i>S.Lt 3</i> time 4 OUT2 operates the same function as OUT1 but in advance by <i>S.Lt 3</i> time 5 OUT2 energises when the buzzer sounds	oF	
13	<i>F.c.n.t</i>	Count mode	uP Up dn Down	uP	
14	<i>F.b.u.F</i>	Buzzer operating mode	oF Disabled 1 The internal buzzer activates at the end of <i>S.Lt 1</i> for <i>S.Lt 2</i> period and when keys are pressed 2 The internal buzzer activates at the end of <i>S.Lt 1</i> for <i>S.Lt 2</i> period 3 The internal buzzer only activates when keys are pressed 4 Only the external buzzer activates only at the end of <i>S.Lt 1</i> for <i>S.Lt 2</i> period (if OUT2 configured with <i>F.o.2.t</i> = 5).	1	
15	<i>t.U.F.t</i>	 -START/STOP key operating mode	oF No function 1 RESET only 2 RESET-START/STOP if <i>iF.c.t</i> = 1/2 or RESET/START/STOP if <i>iF.c.t</i> = 5/6	2	
16	<i>t.E.d.t</i>	Set times visible with fast set time procedure (  key)	oF No set time visibility 1 <i>S.Lt 1</i> 2 <i>S.Lt 2</i> 3 <i>S.Lt 1</i> and <i>S.Lt 2</i> 4 <i>S.Lt 3</i> 5 <i>S.Lt 1</i> and <i>S.Lt 3</i> 6 <i>S.Lt 2</i> and <i>S.Lt 3</i> 7 <i>S.Lt 1</i> , <i>S.Lt 2</i> and <i>S.Lt 3</i> 8 <i>S.Lt 1</i> only directly with the  /  keys with no  key pressed	1	
17	<i>F.b.u.t</i>	Backup operation mode	1 The timing count resets 2 The timing count stops at the value reached when the power supply ceased 3 The timing count stops at the value reached when the power supply ceased and restarts from that value if the conditions for restarting are present	1	
18	<i>t.L.o</i>	Key lock	oF Key lock disabled 1 to 9999s (value in seconds of key inactivity after which the keys are locked)	oF	
19	<i>t.P.P</i>	Passcode for parameters protection	oF Passcode disabled 1 to 9999	oF	

Tempatron: Eltime House, Hall Road, Maldon, Essex, CM9 4NF UK.

Telephone: +44(0)1621 859500 Fax: +44(0)1621 855335 Email: sales@tempatron.co.uk Web: www.tempatron.co.uk

# TEMPATRON

Tempatron Industrial Controls is a division of Eltime Ltd.

© Eltime Ltd. Tempatron TT33 Digital Timers 10/2020