

PRO-ELEC



Solar Spotlights Model: PELL0265

Please read these instructions carefully before use and retain for future reference.

IMPORTANT SAFETY INFORMATION

- Avoid locations of high temperature or humidity.
- The lamp is constructed to IP65 suitable for external use.

WHAT'S INCLUDED

- Lamp assembly x 2.
- User manual.

INSTALLATION

- Installation is simply embedding the spike in the ground ensuring the solar panel is exposed for maximum charging efficiency but not in the vicinity of other strong light source or the low light illumination may not function.
- When the light level is low, press the button on the rear of the solar panel once to turn on low level illumination.
- Press the button again to select high level illumination.
- Press the button again to turn the spotlight off.

OPERATION

- Allow at least 8hrs for the battery to fully charge initially.

NOTE: the lamp does not light except in low ambient light levels.

- When the ambient light falls below a preset level the LEDs will illuminate constantly.
- When set to low level the lamp will illuminate for 6-8hrs and at high level 3-4hrs depending on battery charge level.

CLEANING & MAINTENANCE

- Clean the unit only with a damp cloth. Do not use any chemicals, abrasives or solvents that could damage the casing or lens.
- The internal battery should last for several years but if the performance drops off substantially the battery can be replaced by removing the 4 screws on the rear of the solar panel and lifting off the top panel.
- Only replace the battery by one of identical specification noting the polarity.
- Refit the top panel and replace the screws.
- Allow about 8hrs for the new battery to fully charge.

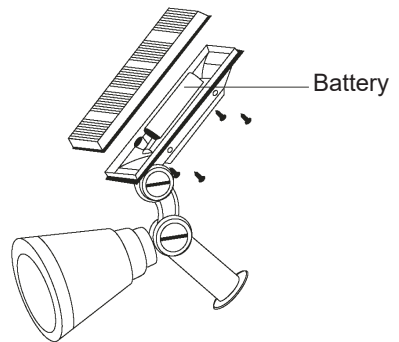

SPECIFICATION

Solar panel: Monocrystal 5V, 200mA

Battery: 1 x 3.7V 2200mAh Li-ion.

LED: 4 x white LED

Working time: up to 6-8 hours.



INFORMATION ON WASTE DISPOSAL FOR CONSUMERS OF ELECTRICAL & ELECTRONIC EQUIPMENT.

When this product has reached the end of its life it must be treated as Waste Electrical & Electronic Equipment (WEEE). Any WEEE marked products must not be mixed with general household waste, but kept separate for the treatment, recovery and recycling of the materials used. Contact your local authority for details of recycling schemes in your area.



Made in China
PO Box 13362 Dublin 2
PR2 9PP

Man Rev 1.1