

40 V Max Stepping Motor Driver for Automotive

BD63800MUF-C

General Description

BD63800MUF-C is a bipolar low-consumption driver that is driven by PWM current. Rated power supply voltage of the device is 40 V, and rated output current is 1.35 A. BD63800MUF-C has two input interface as driving mode: CLK-IN and SPI-IN, and six excitation modes: Full step, 1/2, 1/4, 1/8, 1/16 and 1/32 step. Mix Decay Mode: the seamless adjustment function of slow/fast decay ratio, and Auto Decay Mode: Automatic switching function of slow/fast decay, can realize the optimized control status for all kinds of motor. In addition, BD63800MUF-C operates with single power supply which can simplify the set design.

Features

- AEC-Q100 Qualified (Note 1)
- Low ON Resistance DMOS Output
- CLK-IN Drive Mode
- PWM Constant Current Control (Separately Excited)
- Built-in Spike Noise Cancel Function (No external noise filter is required)
- Supported Modes: Full step, 1/2, 1/4, 1/8, 1/16 and 1/32 step
- Excitation Mode Switching Timing Free
- Current Decay Mode Switch Function
Mix Decay: Linear Adjustment of Slow Decay / Fast Decay Ratio
Auto Decay: Automatic Switch of Slow Decay / Fast Decay
- Selectable Rotation Direction: Clockwise/Counter Clockwise
- Power Save Function
- Built-in Pull-down Resistors for Logic Input
- Power-on Reset Function
- Malfunction prevention function w/o power supply (Ghost Supply Prevention Function)
- Thermal Shutdown Function (TSD)
- Thermal Warning Function (TW)
- Over Current Protection Function (OCP)
- Over Voltage Lock-out Function (OVLO)
- Under Voltage Lock-out Function (UVLO)
- Under Voltage Motor Hold Function
- Open Detection Function
- Stall Detection Function
- Adjacent Pin Short Protection

(Note 1) Grade 1

Applications

- Head-up Display
- LED Headlight
- etc.

Key Specifications

- Supply Voltage Range: 6.0 V to 28.0 V
- Output Current Rating (peak): 1.35 A
- Output Current Rating (DC): 1.21 A
- Output On Resistance (up and down): 0.75 Ω
- Operating Temperature Range: -40 °C to +125 °C

Package

W (Typ) x D (Typ) x H (Max)

VQFN32FBV050

5.0 mm x 5.0 mm x 1.0 mm

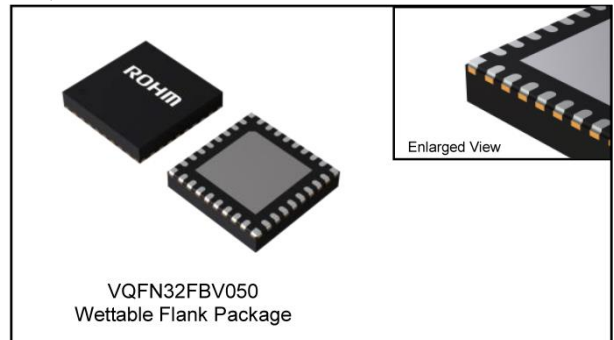

Typical Application Circuits

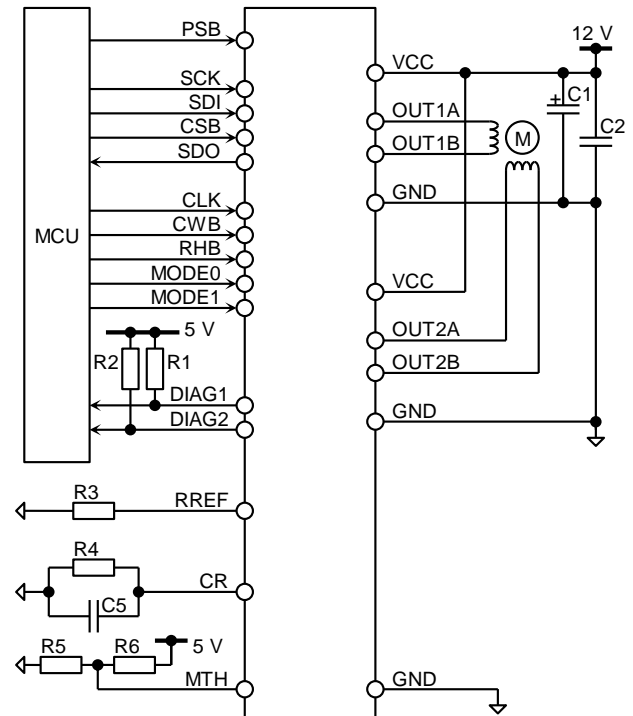

Contents

General Description	1
Features.....	1
Applications	1
Key Specifications	1
Package.....	1
Typical Application Circuits	1
Contents	2
Pin Configuration	4
Pin Description.....	4
Block Diagram	5
Function Description	6
Detailed Description for Pin Function	6
CLK (Clock Input Pin for Micro Step).....	6
MODE0, MODE1 (Motor Excitation Mode Selection Pin)	6
CWB (Motor Rotation Direction Selection Pin)	7
RHB (Drive/Hold Mode Selection Pin)	7
PSB (Power Save Pin).....	7
VCC (Power Supply Pin)	8
GND (Ground Pin).....	8
OUT1A, OUT1B, OUT2A, OUT2B (H-Bridge Output Pin).....	8
RREF (Output Current Level Setting Pin).....	8
CR (Chopping Frequency Setting Pin).....	9
MTH (Current Damping Method Setting Pin).....	9
NC Pins	9
IC Backside Metal.....	9
PWM Constant Current control	10
Current Decay Mode.....	11
Slow Decay Mode.....	11
Fast Decay Mode	11
Mix Decay Mode.....	12
Auto Decay Mode.....	12
Translator Circuit Operation	13
Reset Operation	13
Initializing sequence when power supply is turned on.....	13
Initialization sequence during motor operation	13
Control Input Timing.....	14
Switching of CWB	14
Switching of Motor Excitation Mode	15
Cautions on Simultaneous Switching of CWB and Excitation Mode (MODE0, MODE1).....	15
Step Sequence	16
Step Sequence in Full Step Mode.....	16
Step Sequence in 1/2, 1/4, 1/8, 1/16 and 1/32 Step Modes	17
Drive Mode and Hold Mode.....	21
SPI Interface	22
Examples of SPI Input / Output Sequence	23
SPI Bit Count Error Detection	24
Multi IC connection example.....	24
Protection/Detection Functions	25
Malfunction Prevention Function w/o Power Supply (Ghost Supply Prevention Function)	25
Thermal Shutdown Function (TSD)	25
Thermal Warning Function (TW).....	25
Over Current Protection Function (OCP).....	25
Over Voltage Lock-out Function (OVLO)	25
Under Voltage Lock-out (UVLO) / Under Voltage Motor Hold Function	26
Open Detection Function.....	26
Stall Detection Function.....	27
DIAG Output Selection Function.....	29
Control Register	30
Control Register Map.....	30
Definition of each Control Register Bit.....	31
CR1 (0x01).....	31

CR2 (0x02).....	31
CR3 (0x03).....	31
CR5 (0x05).....	31
CR6 (0x06).....	31
CR7 (0x07).....	32
CR1A (0x11).....	32
CR2A (0x12).....	32
CR5A (0x15).....	33
CR6A (0x16).....	33
Status Register.....	34
Status Register Map.....	34
Definition of each Status Register Bit.....	35
SR1 (0x08).....	35
SR2 (0x09).....	35
SR3 (0x0A).....	36
SR5 (0x0C).....	36
SR6 (0x0D).....	36
SR7A (0x1E).....	37
SR8A (0x1F).....	37
Power-on Sequence.....	38
Power Dissipation.....	39
Thermal Calculation.....	39
Absolute Maximum Rating.....	40
Recommended Operating Condition.....	40
Thermal Resistance.....	40
Electrical Characteristics.....	41
I/O Equivalence Circuit.....	43
Operational Notes.....	44
1. Reverse Connection of Power Supply.....	44
2. Power Supply Lines.....	44
3. Ground Voltage.....	44
4. Ground Wiring Pattern.....	44
5. Recommended Operating Conditions.....	44
6. Inrush Current.....	44
7. Testing on Application Boards.....	44
8. Inter-pin Short and Mounting Errors.....	44
9. Unused Input Pins.....	44
10. Regarding the Input Pin of the IC.....	45
11. Ceramic Capacitor.....	45
12. Thermal Shutdown Circuit (TSD).....	45
13. Over Current Protection Circuit (OCP).....	45
Ordering Information.....	46
Marking Diagram.....	46
Physical Dimension and Packing Information.....	47
Revision History.....	48

Pin Configuration

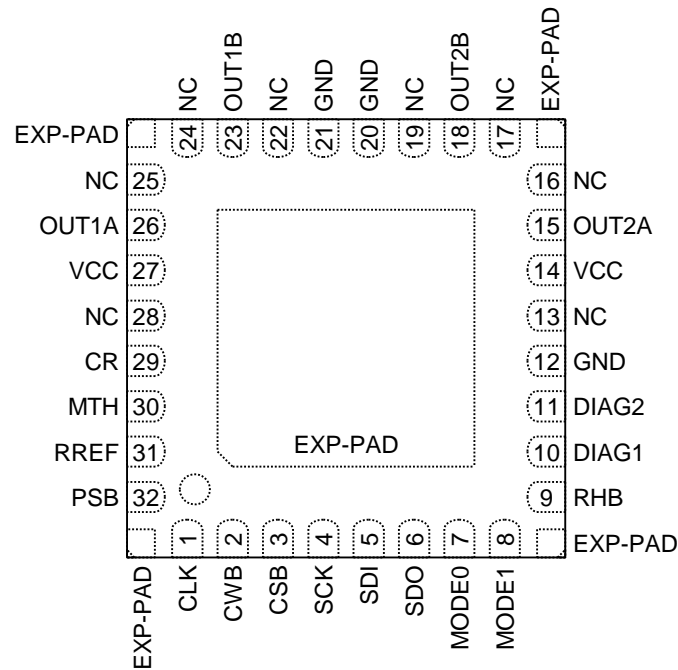

(TOP VIEW)

Pin Description

Pin No.	Pin Name	P/G/I/O	Function
1	CLK	Input	Micro step clock input pin
2	CWB	Input	Motor rotation direction selection pin
3	CSB	Input	Serial interface chip select pin
4	SCK	Input	Serial interface clock pin
5	SDI	Input	Serial interface data input pin
6	SDO	Output	Serial interface data output pin
7	MODE0	Input	Motor excitation mode selection pin
8	MODE1	Input	Motor excitation mode selection pin
9	RHB	Input	Motor drive / hold mode selection pin
10	DIAG1	Output	Protection / detection output pin
11	DIAG2	Output	Protection / detection output pin
15	OUT2A	Output	H-bridge output pin
18	OUT2B	Output	H-bridge output pin
23	OUT1B	Output	H-bridge output pin
26	OUT1A	Output	H-bridge output pin
29	CR	Output	Chopping frequency setting pin
30	MTH	Input	Current decay mode setting pin
31	RREF	Input	Output current level setting pin
32	PSB	Input	Power save pin
14, 27	VCC	Power	Input power supply pin
12, 20, 21	GND	Ground	Ground pin
13, 28	NC	-	No-Connection (Keep this pin open to avoid damage when it shorts with the VCC pin)
16, 17, 19, 22, 24, 25	NC	-	No-Connection
-	EXP-PAD	Ground	Connect central EXP-PAD to GND The central EXP-PAD and the corner EXP-PADs are shorted inside the package

Block Diagram

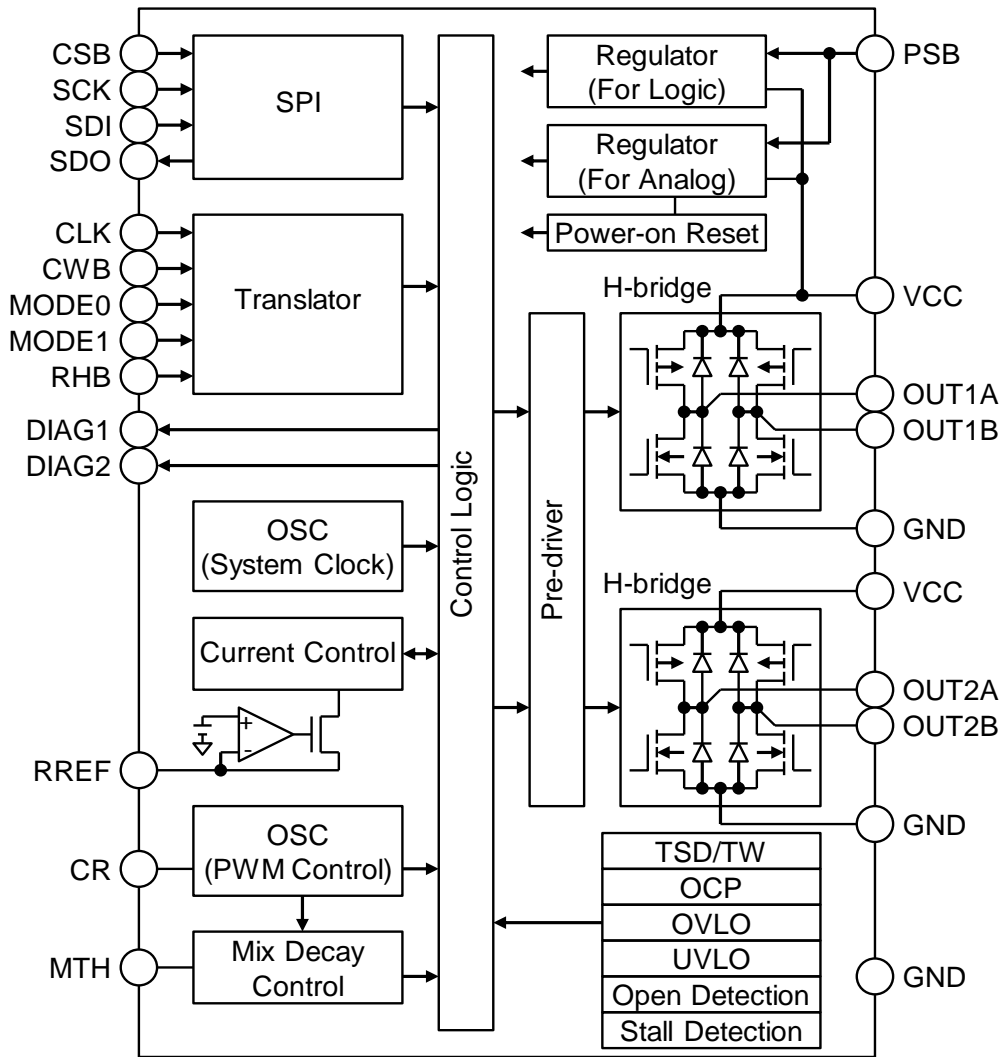

Function Description

Detailed Description for Pin Function

CLK (Clock Input Pin for Micro Step)

The electrical angle changes by one step for each rising edge of input clock pulse.

The effect is also the same when '1' is written to CLKP in the Control Register.

Noise introduced to the CLK pin can cause missteps in motor. Design the PCB layout so that noise will not affect the CLK input easily.

MODE0, MODE1 (Motor Excitation Mode Selection Pin)

These pins set the motor excitation mode. The motor excitation mode can also be set through SM[2:0] in the Control Register.

The setting change of excitation mode is forcibly reflected regardless of the clock pulse input to the CLK pin. Refer to [P15 Switching of Motor Excitation Mode](#).

In case SM[2:0] is not used (SM[2:0] = '000'):

MODE1	MODE0	Excitation Mode
L	L	Full step
L	H	1/2 step
H	L	1/8 step
H	H	1/16 step

In case the MODE1 and MODE0 pins are not used (MODE1 = L and MODE0 = L):

SM2	SM1	SM0	Excitation Mode
0	0	0	Full step
0	0	1	1/2 step
0	1	0	1/8 step
0	1	1	1/16 step
1	0	0	Full step
1	0	1	1/2 step
1	1	0	1/4 step
1	1	1	1/32 step

In case both SM[2:0] and the MODE1, MODE0 pins are used:

SM2	MODE1 xor SM1	MODE0 xor SM0	Excitation Mode
0	0	0	Full step
0	0	1	1/2 step
0	1	0	1/8 step
0	1	1	1/16 step
1	0	0	Full step
1	0	1	1/2 step
1	1	0	1/4 step
1	1	1	1/32 step

Detailed description for Pin function – continued

CWB (Motor Rotation Direction Selection Pin)

This pin sets the direction of the motor rotation. Changes in the CWB pin settings are reflected at the rising edge of the following clock pulse input to the CLK pin. (Refer to [P14 Switching of CWB](#))

The effect of the CWB pin is inverted when CWBP is '1' in the Control Register.

CWBP	CWB	Rotation Direction
0	L	Clockwise The phase of CH1 current output is advanced by 90° from the phase of CH2 current output.
0	H	Counter Clockwise The phase of CH1 current output is delayed by 90° from the phase of CH2 current output.
1	L	Counter Clockwise The phase of CH1 current output is delayed by 90° from the phase of CH2 current output.
1	H	Clockwise The phase of CH1 current output is advanced by 90° from the phase of CH2 current output.

RHB (Drive/Hold Mode Selection Pin)

This pin selects modes from a drive mode where the IC drives output / a hold mode where the IC holds an electrical angle. In the hold mode, the input clock pulse to the CLK pin is ignored and the micro stepping behavior in the internal translator circuit is stopped. The logic of the RHB pin is inverted when RHBP register is '1'. Refer to a table below for each setting.

If MCU changes the motor excitation mode setting (the level of the MODE0 pin and the MODE1 pin and the value of SM[2:0] register) during the hold mode, the actual excitation mode switches after changing from the hold mode to the drive mode.

RHBP	RHB	Mode
0	L	Hold mode
0	H	Drive mode
1	L	Drive mode
1	H	Hold mode

PSB (Power Save Pin)

This pin puts the IC in standby state and sets the motor output to open state. In standby state, the translator circuit is RESET and the electrical angle is initialized.

Note that a maximum of 40 μs is necessary as the recovery period from the standby state to normal state when PSB is set from 'L' to 'H'. Refer to [P13 Reset Operation](#).

PSB	Motor Output State
L	Standby State (RESET)
H	ACTIVE

The initial electrical angle of each excitation mode after RESET is as follows. (Refer to [P16 Step Sequence](#))

Excitation mode	Initial electrical angle
Full step	45°
1/2 step	45°
1/4 step	45°
1/8 step	45°
1/16 step	45°
1/32 step	45°

Detailed description for Pin function – continued**VCC (Power Supply Pin)**

Since the motor driving current flows into the VCC pin, design the PCB layout with low impedance by making the trace for the VCC pin thick and short. VCC voltage has large fluctuations due to back electromotive force of the motor, PWM switching noise etc. In order to stabilize VCC voltage level, place the bypass capacitors (ranged from 100 μF to 470 μF) as close as possible to the VCC pin.

Larger capacitors are necessary especially when the application needs larger current or when the motor has large back electromotive force. In addition, we recommend placing multilayer ceramic capacitors (ranged from 0.01 μF to 0.1 μF) in parallel to the bypass capacitor. The purpose is to decrease the impedance of the power supply in a wide frequency bandwidth.

Higher VCC voltage level than the rating is prohibited even for a moment.

Make sure to short all VCC pins on the PCB layout though they are shorted inside IC. When these are not shorted, malfunction or destruction may occur because of current flow concentration.

Each power supply pin has a built-in clamper for preventing electrostatic damage. When a steep pulse signal or voltage, such as a surge exceeding the absolute maximum rating is applied to power supply pins, the clammers are actuated and destroyed. Therefore, do not exceed the absolute maximum rating. It is also recommended to attach a Zener diode that matches the absolute maximum rating.

Between the VCC pins and the GND pins, diodes are inserted for preventing electrostatic damage. Note that the IC will be destroyed if reversed voltage is applied between them.

GND (Ground Pin)

In order to reduce the noise caused by switching current and to stabilize the internal reference voltage of IC, design the PCB layout to make the wiring impedance from these pins as low as possible to achieve the lowest electrical potential in any operating conditions. Design the PCB layout so that it does not have common impedance with other GND patterns.

OUT1A, OUT1B, OUT2A, OUT2B (H-Bridge Output Pin)

Since the motor driving current flows into these pins, design the PCB layout with low impedance by making the trace for the output pin thick and short. It is recommended to add Schottky diodes in case that the output voltage swings largely between positive and negative side in an application with large current, and in case that the back electromotive voltage level is large. Each output pin has a built-in clamper for preventing electrostatic damage. When a steep pulse signal or voltage, such as a surge exceeding the absolute maximum rating is applied to the power supply pins, the clammers are actuated and destroyed. Therefore, do not exceed the absolute maximum rating.

RREF (Output Current Level Setting Pin)

This pin is used to set output current level. The maximum output current value can be set by RREF voltage and current-sensing resistor (RREF resistor).

$$I_{OUT} = \frac{V_{RREF}}{R_{RREF}} \times 14,900 \text{ [A]}$$

Where:

I_{OUT} is the Maximum Output Current

V_{RREF} is the RREF Voltage [V]. 0.457 V (Typ).

R_{RREF} is the RREF Resistor [Ω]. 6.2 kΩ to 43 kΩ.

If the RREF pin is open, the output current is set to 700 mA. The minimum current that can be controlled by the RREF resistor, will depend on L/R value of the motor coil and the minimum ON time of PWM Drive.

Detailed description for Pin function – continued

CR (Chopping Frequency Setting Pin)

This pin is to set the output chopping frequency. Connect an external capacitance (470 pF to 1500 pF) and resistor (10 kΩ to 200 kΩ) to GND.

Refer to 3) CR Timer in [P10 PWM Constant Current control](#) for setting method of the chopping frequency.

In PCB, ensure that GND line from the external components has no common impedance with other GND patterns. Also ensure that it is far from wires with steep pulses like square waves, etc. to prevent noise.

Both of capacitance and resistance must be attached when PWM constant current control is used. The control doesn't work correctly if the external voltage is applied to the CR pin.

MTH (Current Damping Method Setting Pin)

This pin is for setting the current decay method. It can be selected by changing the input voltage level.

Input voltage in the MTH pin	Current Decay Method
0.0 V to 0.3 V	Slow Decay
0.4 V to 1.0 V	Mix Decay
1.5 V to 2.0 V	Fast Decay
2.5 V or more, or open	Auto Decay

In case of using slow decay mode, connect MTH to GND. If MTH voltage is generated by a voltage divider composed of resistors, select the resistance value in taking the outflow current (Max 2 μA) and the internal pull-up resistor (1 MΩ) into consideration. Refer to [P11 Current Decay Mode](#) for each current decay method.

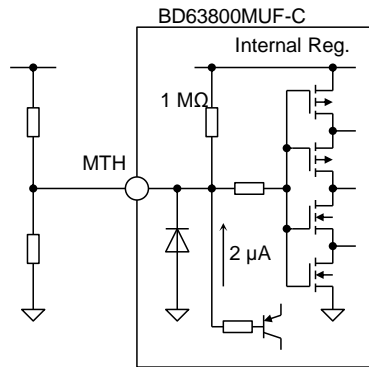
**NC Pins**

These are no connection pins. They are not connected electrically to the internal circuit of IC.

IC Backside Metal

VQFN32FBV050 package has a metal for heat dissipation on the back of the IC. Since the heat is supposed to be dissipated through this metal, the metal must be connected to GND plane on substrate with soldering and GND pattern as large as possible must be used for the sufficient heat dissipation area.

In addition, the backside metal is shorted to the back of the IC chip. So the backside metal is at GND potential. If it is shorted to a potential other than GND potential, malfunction and destruction will occur. Don't route signals other than GND potential at the back-side of the IC

Function Description – continued

PWM Constant Current control

1) Current Control Operation

The output current increases when the output transistor is turned on. When the current reaches the level set by RREF resistor and DAC in IC, the current limit comparator operates, then the IC enters current decay mode. After a wait period set by CR timer, the output transistor turns on again. This sequence repeats continuously.

2) Noise Canceling Function

To avoid misdetection of current-sense comparator caused by spike noise generated when the output turns ON, the IC has a minimum ON time t_{ONMIN} (Blank time). The current detection is invalid for the minimum ON time after the output transistor is turned on.

3) CR Timer

The CR pin is repeatedly charged and discharged between the VCRH and VCRL levels through the external capacitor and resistor.

The detection of the current-sense comparator is disabled while charging from VCRL level to VCRH level.

This charging period is the minimum ON Time: t_{ONMIN} .

After CR level reaches VCRH, CR starts discharging. During this discharge period, IC enters current decay mode when the output current reaches the target current level.

When CR is discharged to VCRL level, IC recovers to output ON mode from current decay mode. At the same time, IC starts charging again.

CR charging time: the minimum ON Time t_{ONMIN} and CR discharge time $t_{DISCHARGE}$ are determined by the following formula (Typ) with external capacitor (C) and resistor (R). The sum of two parameters is the chopping cycle time t_{CHOP} .

$$t_{ONMIN} \approx C \times \frac{R \times R'}{R + R'} \times \ln \left(\frac{VCR - 0.4}{VCR - 1.0} \right) \quad [s]$$

$$t_{DISCHARGE} \approx C \times R \times \ln \left(\frac{1 + \alpha}{0.4} \right) \quad [s]$$

$$t_{CHOP} \approx t_{ONMIN} + t_{DISCHARGE} \quad [s]$$

Where:

- R is the external resistor in the CR pin
- C is the external capacitor in the CR pin
- V is the internal regulator output voltage. 5 V (Typ)
- R' is the internal impedance in the CR pin. 5 kΩ (Typ)
- α is referred to the chart to the right

$$VCR = \frac{R}{R + R'} \times V$$

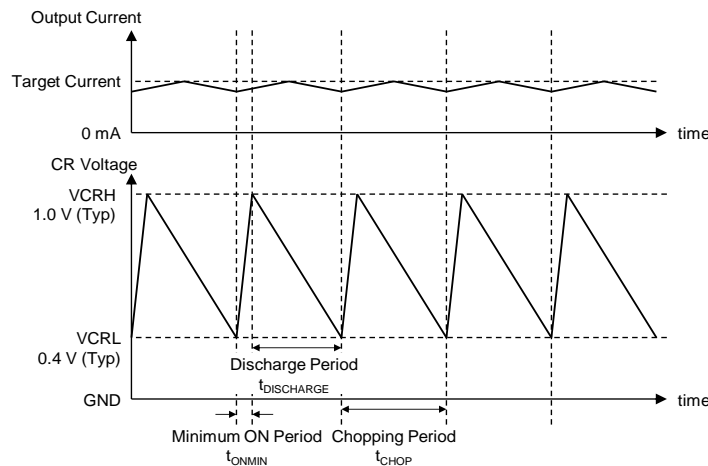
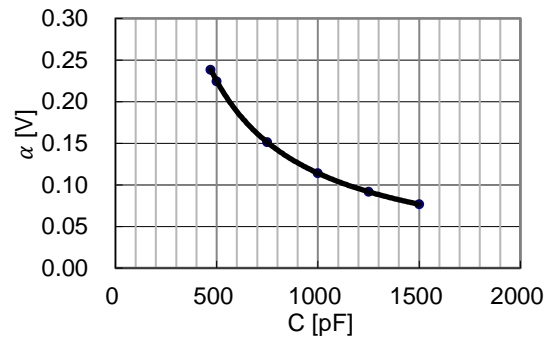

Figure 1. Timing Chart of CR Voltage and Output Current

Use 10 kΩ or more for the resistor in the CR pin since CR level doesn't reach VCRH level with lower resistor values. (10 kΩ to 200 kΩ is recommended).

For the capacitor in the CR pin, the minimum ON time: t_{ONMIN} will become long by the capacitance value of over several thousand pF. So note that output current may exceed the target current level depending on L and R values of the motor coils (470 pF to 1,500 pF is recommended as the capacitance value).

Note that a very long chopping cycle time: t_{CHOP} causes larger ripple in output current, smaller average output current and lower rotation efficiency. Select the optimum value of the resistor and the capacitor for the CR pin to minimize motor sound and distortion of output current waveform.

PWM Constant Current control - continued

Current Decay Mode

BD63800MUF-C PWM realizes a PWM Constant Current Control with two kinds of decay state (Fast Decay/Slow Decay). The following diagrams show the states of output transistors and paths of the motor regenerative current during current decay period in each decay mode.

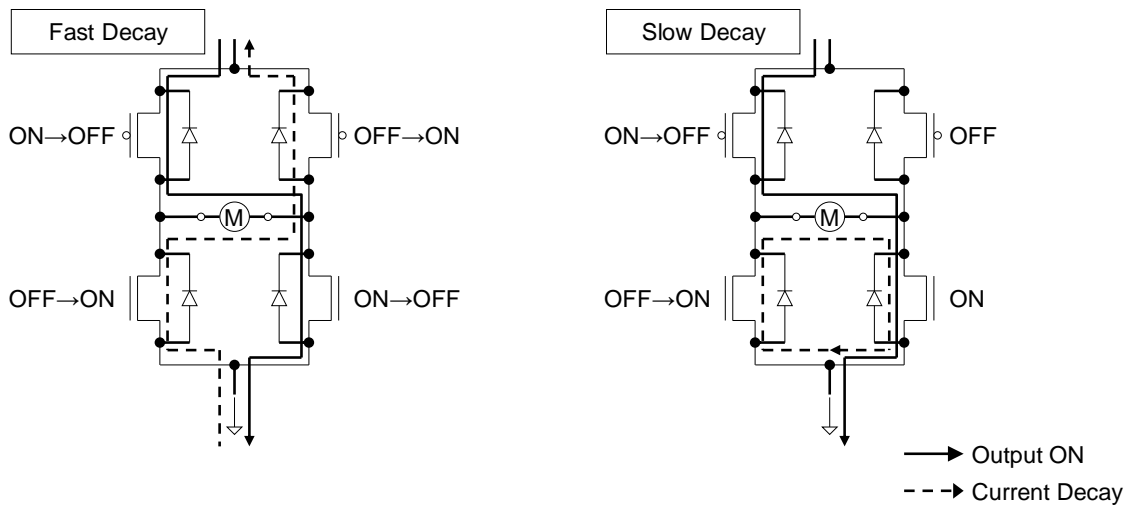

Figure 2. Paths of Regenerated Current during Current Decay

BD63800MUF-C implements 4 decay mode of combination of these decay states in order to realize optimized operation for motor characteristics, excitation mode and pulse rate.

The features of each decay mode are as follows:

Slow Decay Mode

During current decay period, regenerative current decreases slowly because of smaller voltage between both ends of a motor coil. It makes ripple on output current smaller and torque of motor higher.

However, (1) in the lower operating current condition, the output current increases because of lower controllability of current. And (2) in using 1/2 step to 1/32 step with high-pulse-rate driving, the current waveform cannot follow the change of the current target due to the influence of motor back electromotive voltage. As the result, the distortion and motor vibration are increased.

Thus, this decay mode is suitable for Full step mode or low-pulse-rate driven 1/2 step to 1/32 step modes.

Fast Decay Mode

The regeneration current is decreased quickly, so distortion of the output current waveform is reduced even in the high-pulse-rate driving condition

However, the average current is reduced by large ripple of output current. It causes (1) Motor torque reduction (This issue can be solved by larger current limit setting though the rated output current must be satisfied) and (2) Heat Generation caused by motor power loss.

If these points can be allowed, fast decay is stable for high-pulse rate 1/2 step to 1/32 step modes.

PWM Constant Current control - continued

Mix Decay Mode

The mix decay mode can improve issues caused in both of slow and fast decay mode. It can improve current controllability without increasing the current ripple by switching slow and fast decay states during current decay period. In addition, the time ratio of slow decay and fast decay can be adjusted by the voltage applied to the MTH pin. So it can provide the optimal control state for any kind of motors. In decay state, period from t1 to t2 of the discharge section of the CR pin in the chopping cycle t_{CHOP} is the slow decay, and the remaining interval from t2 to t3 is the fast decay. If the current doesn't reach the target value during the period from t1 to t2, the slow decay is skipped and only fast decay is applied.

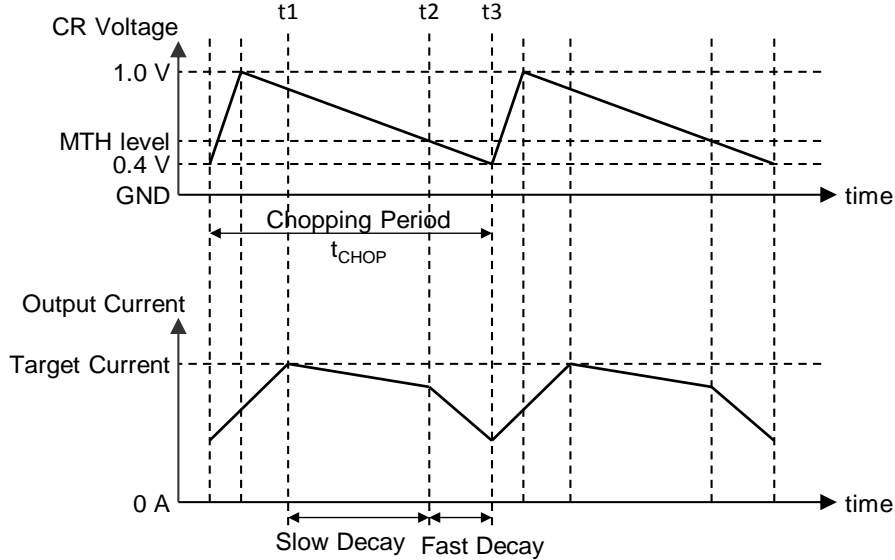

Figure 3. CR Pin Voltage and Output Current during Mix Decay

Auto Decay Mode

In the auto decay mode automatically select fast decay and slow decay during decay state according to the difference between the target current and the output current. It causes small current ripple and quick following for the change of target current. For example, when target current drops and the output current is excess the target current, Fast decay is selected as current decay mode.

Current waveform in Auto decay is shown below.

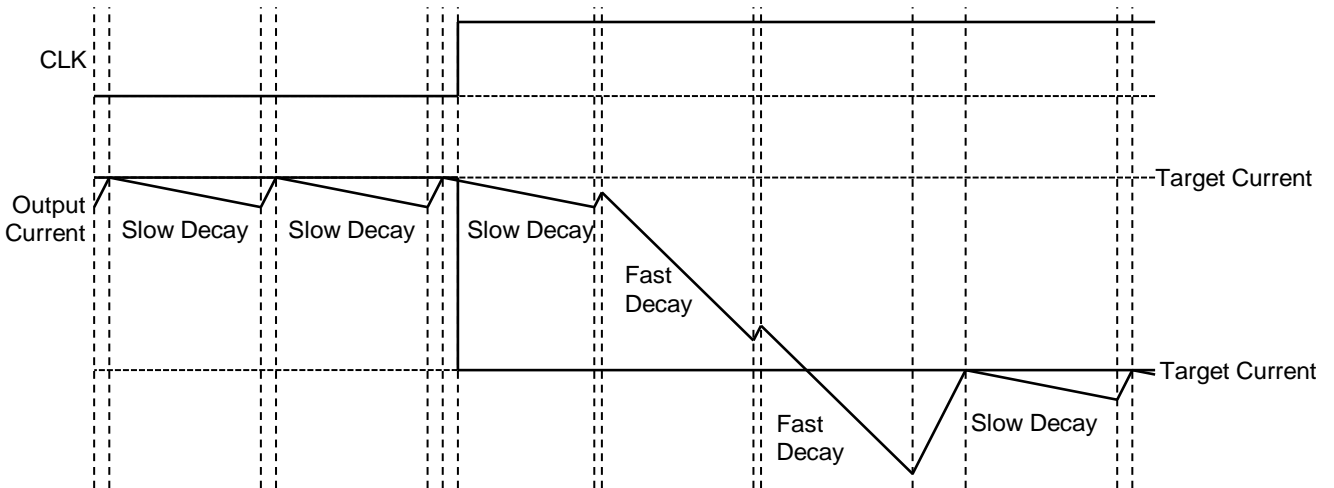

Figure 4. Current Decay by Auto Decay in Reducing Target Current

Function Description – continued

Translator Circuit Operation

This IC has a built-in translator circuit and can drive stepping motors by CLK-IN mode and SPI command. The operation of the translator circuit in CLK-IN drive mode is described below.

Reset Operation

The translator circuit is initialized by power ON reset function and the PSB pin.

Initializing sequence when power supply is turned on

(1) Power-on in PSB = L (Recommended)

When power supply is turned on, the internal power-on reset function initializes IC. During PSB = L, IC is in standby state and the motor output keeps open state. After PSB = Low to High, IC enters normal state and it can accept SPI command. In this state, by setting '1' to MOTEN in the control register CR1 by SPI, IC enters active state and the motor output becomes active and the excitation starts in the initial electrical angle.

Note that there is 40 μs (Max) delay from the standby state to the normal state when PSB = L → H.

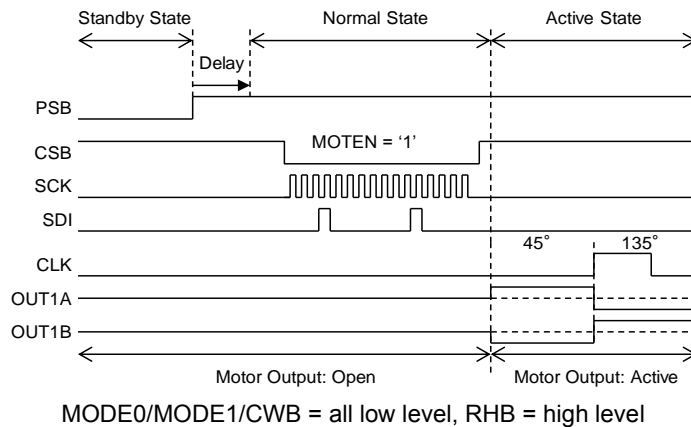

(2) Power-on in PSB = H

When power supply is turned on, the Power-on reset function in IC operates and the IC is initialized. Then, by setting '1' to MOTEN in the control register CR1 by SPI, IC enters active state and the motor output becomes active and the excitation starts in the initial electrical angle. However, there is a possibility that IC is not initialized normally if VCC rises up rapidly because of no Power-on reset operation. In that case, set PSB level to ground level once after VCC rises up. (Refer to [P38 Power-on Sequence](#) and [P14 Control Input Timing](#))

Initialization sequence during motor operation

Input a reset signal to the PSB pin to initialize translator circuit during motor operation. IC is reset only by the PSB pin regardless of the other input signals. After reset, IC internal circuit enters the normal state and makes the motor output open. Note that there is 40 μs (Max) delay from the standby state to the normal state when PSB = L → H.

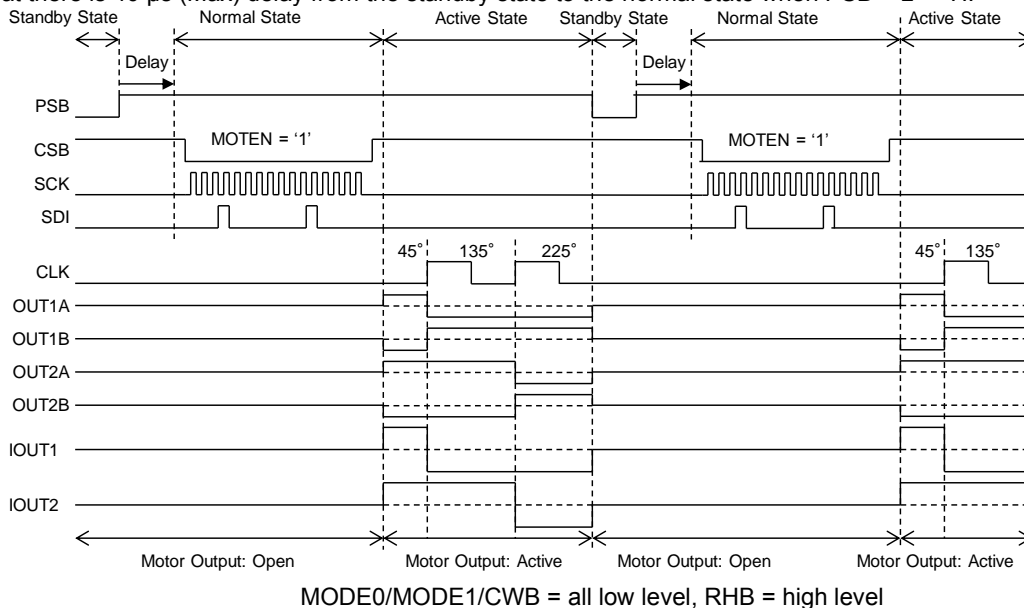

Translator Circuit Operation - continued

Control Input Timing

The translator circuit operates at the rising edge of the CLK signal. The input timing shown below must be satisfied.

Note that there is a risk that the translator circuit will not operate as expected if input timing is violated.

There is 40 μs (Max) delay from the standby state to the normal state when PSB = L → H (Interval B). Note that SPI command input during the delay period is not acceptable.

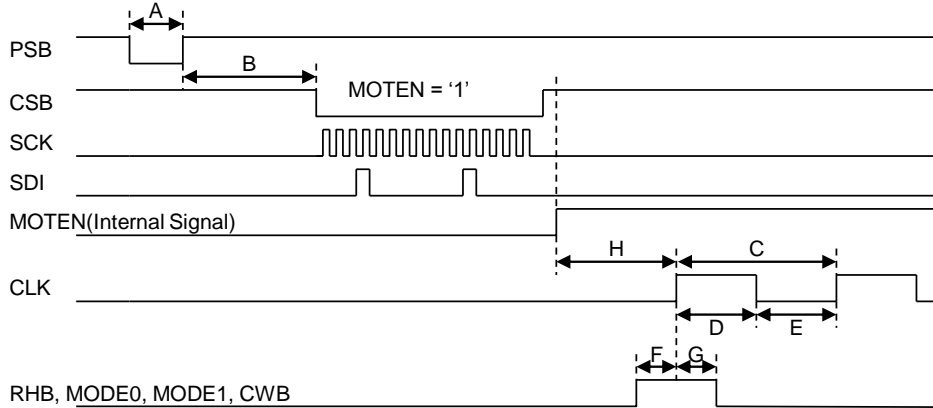

Symbol	Item	Required Time
A	Low pulse width of PSB	20 μs (Min)
B	Period from PSB rising edge to SPI command input start time	40 μs (Max)
C	Cycle time of CLK	4 μs (Min)
D	High pulse width of CLK	2 μs (Min)
E	Low pulse width of CLK	2 μs (Min)
F	Set-up time of RHB, MODE0, MODE1, CWB for CLK	1 μs (Min)
G	Hold time of RHB, MODE0, MODE1, CWB for CLK	1 μs (Min)
H	Setup time of MOTEN for CLK	1 μs (Min)

Switching of CWB

The switch in CWB is reflected at the next rising edge of CLK after CWB is changed.

However, depending on the motor status at CWB switching, there are possibilities of step-out or misstep in motor when the motor cannot follow the input even if the control input for driver IC is valid. Therefore, the transition sequence must be evaluated with application condition well.

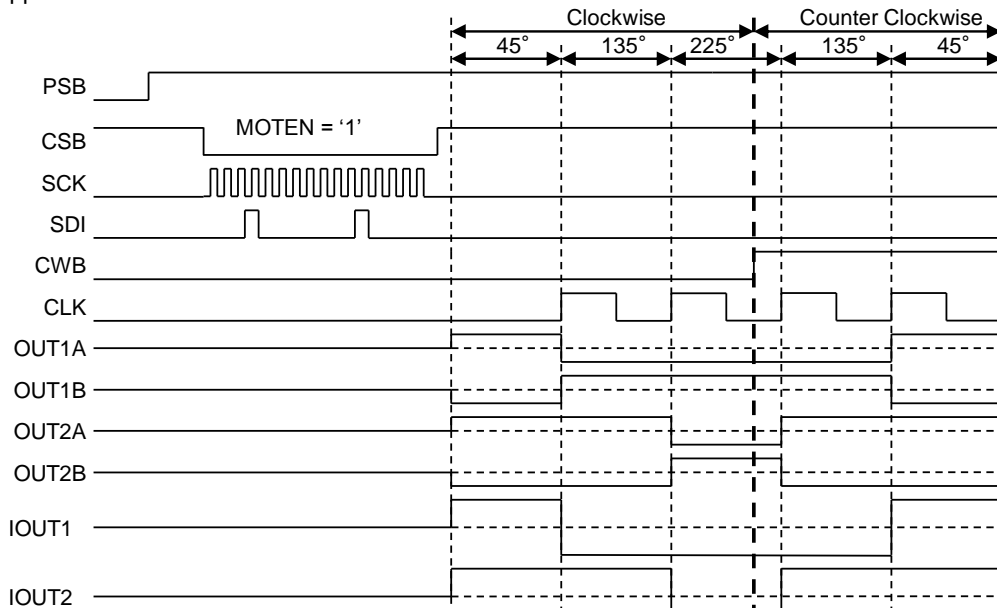

MODE0/MODE1 = all low level, RHB = high level

Translator Circuit Operation - continued

Switching of Motor Excitation Mode

The excitation mode is switched at the timing of changing MODE0, MODE1 level regardless of CLK signal.

This product has a function which can prevent motor out-of-step caused by discrepancies of torque vector between transition excitations. However, depending on the motor status at MODE0 and MODE1 switching, there are possibilities of step-out or misstep in motor when the motor cannot follow the input even if the control input for driver IC is valid. Therefore, evaluate the switching sequence of excitation mode fully.

Cautions on Simultaneous Switching of CWB and Excitation Mode (MODE0, MODE1)

Interval A is defined as the period from reset (PSB = L → H) to the 1st CLK pulse input and Interval B is defined as the period after the 1st CLK pulse input as shown in the figure below.

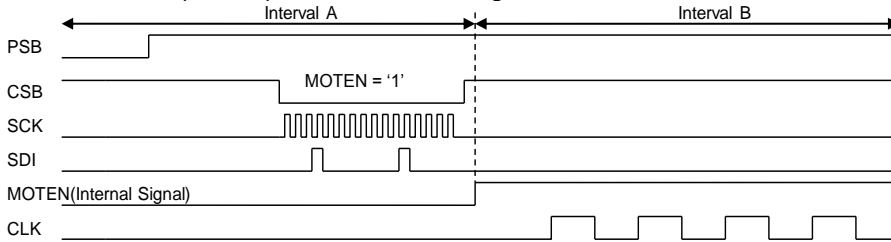

Interval A	There is no constraint in switching CWB and the excitation mode.
Interval B	During one CLK cycle or MOTEN = L, simultaneous switching of CWB and excitation mode should be avoided. If this is violated, it is possible to have misstep of motor (extra one more step) and out-of-step in motor.

Therefore, when switching CWB and excitation mode simultaneously, reset first the IC by setting PSB = L → H. Then set CWB and excitation mode during interval A.

Translator Circuit Operation – continued

Step Sequence

In motor stepping, Micro-step Position (MSP), IOUT current ratio and electric angle of each step are decided depending on the excitation mode. The initial excited position is 45° in all excitation modes.

Step Sequence in Full Step Mode

Timing chart, MSP, IOUT current ratio and the electric angle for Full step mode are shown in the figure below.
 ({SM2, MODE1 xor SM1, MODE0 xor SM0} = '100' or '000', CWB = High)

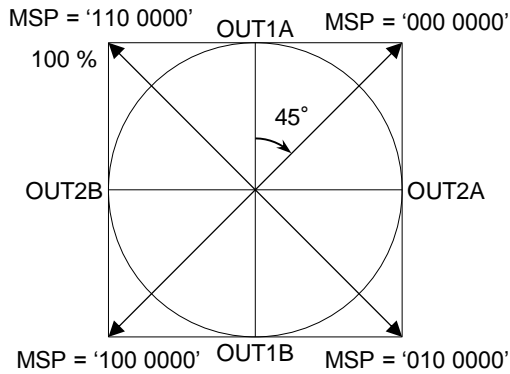
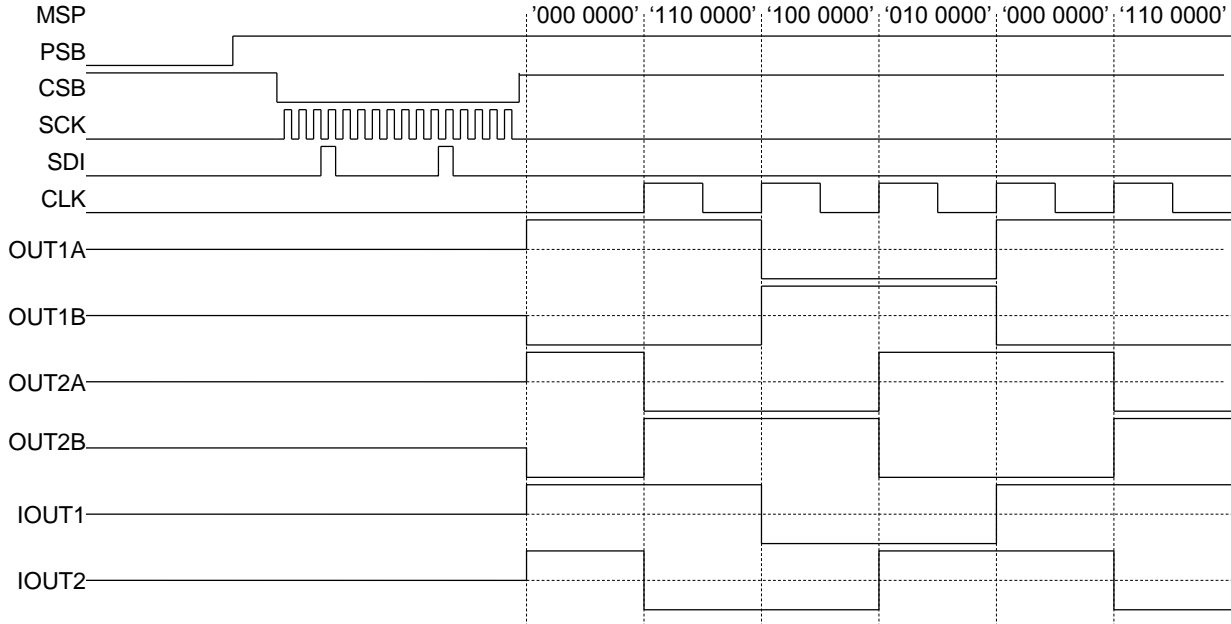

Step Sequence - continued

Step Sequence in 1/2, 1/4, 1/8, 1/16 and 1/32 Step Modes

MSP, IOUT current ratio and the electric angle for 1/2, 1/4, 1/8, 1/16 and 1/32 step of each excitation mode are shown in the figure below. (CWB = L)

MSP[6:0]	Step Mode {SM2, MODE1 xor SM1, MODE0 xor SM0}					% of I _{max}		Step angle [°]
	111	011	010	110	101 / 001	Coil 1	Coil 2	
	1/32	1/16	1/8	1/4	1/2			
111 0000	112	56	28	14	7	100.0	0.0	0.0
111 0001	113					99.9	4.9	2.8
111 0010	114	57				99.5	9.8	5.6
111 0011	115					98.9	14.7	8.5
111 0100	116	58	29			98.1	19.5	11.2
111 0101	117					97.0	24.3	14.1
111 0110	118	59				95.7	29.0	16.9
111 0111	119					94.2	33.7	19.7
111 1000	120	60	30	15		92.4	38.3	22.5
111 1001	121					90.4	42.8	25.3
111 1010	122	61				88.2	47.1	28.1
111 1011	123					85.8	51.4	30.9
111 1100	124	62	31			83.1	55.6	33.8
111 1101	125					80.3	59.6	36.6
111 1110	126	63				77.3	63.4	39.4
111 1111	127					74.1	67.2	42.2
000 0000	0	0	0	0	0	70.7	70.7	45.0
000 0001	1					67.2	74.1	47.8
000 0010	2	1				63.4	77.3	50.6
000 0011	3					59.6	80.3	53.4
000 0100	4	2	1			55.6	83.1	56.2
000 0101	5					51.4	85.8	59.1
000 0110	6	3				47.1	88.2	61.9
000 0111	7					42.8	90.4	64.7
000 1000	8	4	2	1		38.3	92.4	67.5
000 1001	9					33.7	94.2	70.3
000 1010	10	5				29.0	95.7	73.1
000 1011	11					24.3	97.0	75.9
000 1100	12	6	3			19.5	98.1	78.8
000 1101	13					14.7	98.9	81.5
000 1110	14	7				9.8	99.5	84.4
000 1111	15					4.9	99.9	87.2

Step Sequence in 1/2, 1/4, 1/8, 1/16 and 1/32 Step Modes – continued

MSP[6:0]	Step Mode {SM2, MODE1 xor SM1, MODE0 xor SM0}					% of I _{max}		Step angle [°]
	111	011	010	110	101 / 001	Coil 1	Coil 2	
	1/32	1/16	1/8	1/4	1/2			
001 0000	16	8	4	2	1	0.0	100.0	90.0
001 0001	17					-4.9	99.9	92.8
001 0010	18	9				-9.8	99.5	95.6
001 0011	19					-14.7	98.9	98.5
001 0100	20	10	5			-19.5	98.1	101.2
001 0101	21					-24.3	97.0	104.1
001 0110	22	11				-29.0	95.7	106.9
001 0111	23					-33.7	94.2	109.7
001 1000	24	12	6	3		-38.3	92.4	112.5
001 1001	25					-42.8	90.4	115.3
001 1010	26	13				-47.1	88.2	118.1
001 1011	27					-51.4	85.8	120.9
001 1100	28	14	7			-55.6	83.1	123.8
001 1101	29					-59.6	80.3	126.6
001 1110	30	15				-63.4	77.3	129.4
001 1111	31					-67.2	74.1	132.2
010 0000	32	16	8	4	2	-70.7	70.7	135.0
010 0001	33					-74.1	67.2	137.8
010 0010	34	17				-77.3	63.4	140.6
010 0011	35					-80.3	59.6	143.4
010 0100	36	18	9			-83.1	55.6	146.2
010 0101	37					-85.8	51.4	149.1
010 0110	38	19				-88.2	47.1	151.9
010 0111	39					-90.4	42.8	154.7
010 1000	40	20	10	5		-92.4	38.3	157.5
010 1001	41					-94.2	33.7	160.3
010 1010	42	21				-95.7	29.0	163.1
010 1011	43					-97.0	24.3	165.9
010 1100	44	22	11			-98.1	19.5	168.8
010 1101	45					-98.9	14.7	171.5
010 1110	46	23				-99.5	9.8	174.4
010 1111	47					-99.9	4.9	177.2

Step Sequence in 1/2, 1/4, 1/8, 1/16 and 1/32 step Modes – continued

MSP[6:0]	Step Mode {SM2, MODE1 xor SM1, MODE0 xor SM0}					% of I _{max}		Step angle [°]
	111	011	010	110	101 / 001	Coil 1	Coil 2	
	1/32	1/16	1/8	1/4	1/2			
011 0000	48	24	12	6	3	-100.0	0.0	180.0
011 0001	49					-99.9	-4.9	182.8
011 0010	50	25				-99.5	-9.8	185.6
011 0011	51					-98.9	-14.7	188.5
011 0100	52	26	13			-98.1	-19.5	191.2
011 0101	53					-97.0	-24.3	194.1
011 0110	54	27				-95.7	-29.0	196.9
011 0111	55					-94.2	-33.7	199.7
011 1000	56	28	14	7		-92.4	-38.3	202.5
011 1001	57					-90.4	-42.8	205.3
011 1010	58	29				-88.2	-47.1	208.1
011 1011	59					-85.8	-51.4	210.9
011 1100	60	30	15			-83.1	-55.6	213.8
011 1101	61					-80.3	-59.6	216.6
011 1110	62	31				-77.3	-63.4	219.4
011 1111	63					-74.1	-67.2	222.2
100 0000	64	32	16	8	4	-70.7	-70.7	225.0
100 0001	65					-67.2	-74.1	227.8
100 0010	66	33				-63.4	-77.3	230.6
100 0011	67					-59.6	-80.3	233.4
100 0100	68	34	17			-55.6	-83.1	236.2
100 0101	69					-51.4	-85.8	239.1
100 0110	70	35				-47.1	-88.2	241.9
100 0111	71					-42.8	-90.4	244.7
100 1000	72	36	18	9		-38.3	-92.4	247.5
100 1001	73					-33.7	-94.2	250.3
100 1010	74	37				-29.0	-95.7	253.1
100 1011	75					-24.3	-97.0	255.9
100 1100	76	38	19			-19.5	-98.1	258.8
100 1101	77					-14.7	-98.9	261.5
100 1110	78	39				-9.8	-99.5	264.4
100 1111	79					-4.9	-99.9	267.2

Step Sequence in 1/2, 1/4, 1/8, 1/16 and 1/32 step Modes – continued

MSP[6:0]	Step Mode {SM2, MODE1 xor SM1, MODE0 xor SM0}					% of I _{max}		Step angle [°]
	111	011	010	110	101 / 001	Coil 1	Coil 2	
	1/32	1/16	1/8	1/4	1/2			
101 0000	80	40	20	10	5	0.0	-100.0	270.0
101 0001	81					4.9	-99.9	272.8
101 0010	82	41				9.8	-99.5	275.6
101 0011	83					14.7	-98.9	278.5
101 0100	84	42	21			19.5	-98.1	281.2
101 0101	85					24.3	-97.0	284.1
101 0110	86	43				29.0	-95.7	286.9
101 0111	87					33.7	-94.2	289.7
101 1000	88	44	22	11		38.3	-92.4	292.5
101 1001	89					42.8	-90.4	295.3
101 1010	90	45				47.1	-88.2	298.1
101 1011	91					51.4	-85.8	300.9
101 1100	92	46	23			55.6	-83.1	303.8
101 1101	93					59.6	-80.3	306.6
101 1110	94	47				63.4	-77.3	309.4
101 1111	95					67.2	-74.1	312.2
110 0000	96	48	24	12	6	70.7	-70.7	315.0
110 0001	97					74.1	-67.2	317.8
110 0010	98	49				77.3	-63.4	320.6
110 0011	99					80.3	-59.6	323.4
110 0100	100	50	25			83.1	-55.6	326.2
110 0101	101					85.8	-51.4	329.1
110 0110	102	51				88.2	-47.1	331.9
110 0111	103					90.4	-42.8	334.7
110 1000	104	52	26	13		92.4	-38.3	337.5
110 1001	105					94.2	-33.7	340.3
110 1010	106	53				95.7	-29.0	343.1
110 1011	107					97.0	-24.3	345.9
110 1100	108	54	27			98.1	-19.5	348.8
110 1101	109					98.9	-14.7	351.5
110 1110	110	55				99.5	-9.8	354.4
110 1111	111					99.9	-4.9	357.2

Function Description – continued

Drive Mode and Hold Mode

The IC has a drive mode and a hold mode and the peak current for each mode can be set by SPI.

The drive mode = Not (hold mode) and this mode is determined by exclusive OR of the RHB pin and RHBP register.

The peak current in drive mode is determined by IRUN[3:0] register, and the peak current in hold mode is determined by IHOLD[3:0] register. The percentage of peak current for each register value is shown below

IRUN[3:0]	Peak Motor Current IRUN [%]	IHOLD[3:0]	Peak Motor Current IHOLD [%]
0000	9.1	0000	0.0 <i>(Note 1)</i>
0001	10.1	0001	9.1
0010	11.6	0010	10.1
0011	13.0	0011	11.6
0100	15.1	0100	13.0
0101	17.4	0101	15.1
0110	20.3	0110	17.4
0111	24.0	0111	20.3
1000	30.4	1000	24.0
1001	36.1	1001	30.4
1010	42.9	1010	36.1
1011	50.0	1011	42.9
1100	59.5	1100	50.0
1101	70.8	1101	59.5
1110	83.9	1110	70.8
1111	100.0	1111	83.9

(Note 1) Open detection is disabled under this condition.

Function Description – continued

SPI Interface

This IC supports Serial Peripheral Interface (SPI) to set parameter into IC and to read out status data from IC.

SPI frame structure is as follows,

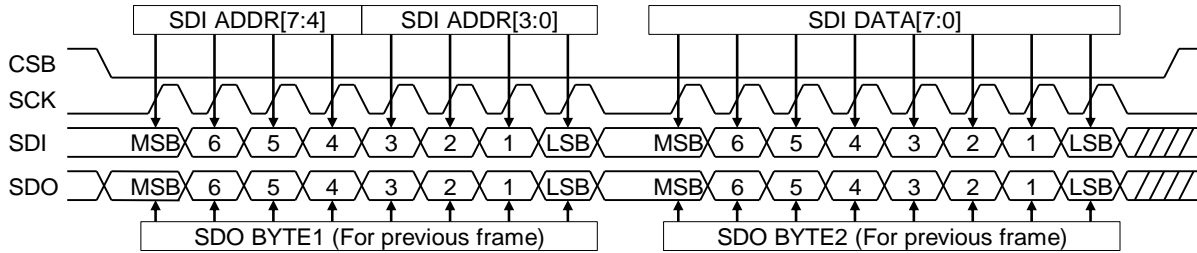

The SPI transfer data length is 16 bits.

When CSB is 'L', the SPI is active and IC latches SDI data at the rising of SCK.

During CSB is 'L', the frame data is stored at every multiples of 16 SCK pulses.

The frame data is not latched internally if the number of SCK pulses is less than 16 after CSB becomes 'L' or after latching frame data.

The structure of SPI address, data input and data output is described below,

SDI ADDR[7:4]	SDI ADDR[3:0]	SDI DATA[7:0]	SDO BYTE1	SDO BYTE2	Comment on Use
ACR1	ACR2	SDICR1	SDOCR1	SDOCR2	Control Register CR1 Data Input Data Output of CR1 and CR2
ACR1	ASR1	SDICR1	SDOCR1	SDOSR1	Control Register CR1 Data Input Data Output of CR1 and SR1
ACR1	NOP	SDICR1	SDOCR1	00h	Control Register CR1 Data Input Data Output of CR1
ASR1	ACR1	XXh	SDOSR1	SDOCR1	Data Output of SR1 and CR1
ASR1	ASR2	XXh	SDOSR1	SDOSR2	Data Output of SR1 and SR2
ASR1	NOP	XXh	SDOSR1	00h	Data Output of SR1
NOP	ACR1	XXh	00h	SDOCR1	Data Output of CR1
NOP	ASR2	XXh	00h	SDOSR2	Data Output of SR2
NOP	NOP	XXh	00h	00h	Dummy/Placeholder

- ACR1, ACR2 : Control Register Address. Refer to [P30 Control Register](#).
- ASR1, ASR2 : Status Register Address. Refer to [P34 Status Register](#).
- SDICR1 : Control Register Data Input
- SDOCR_x, SDOSR_x : Data Output (x = 1, 2)
- NOP : Register Address outside the range
- XXh : Any Value

SPI Interface - continued

Examples of SPI Input / Output Sequence

In writing data to Control Register, the addresses are specified by the first 4 bits, and the data in the last 8bits is stored. Output data is output in 16 bit of the next frame from SDO. The data corresponding to the address indicated in the first 4 bits is output in the first 8 bits of the next frame. The data corresponding to the address indicated in the next 4 bits is output in the last 8 bits of the next frame.

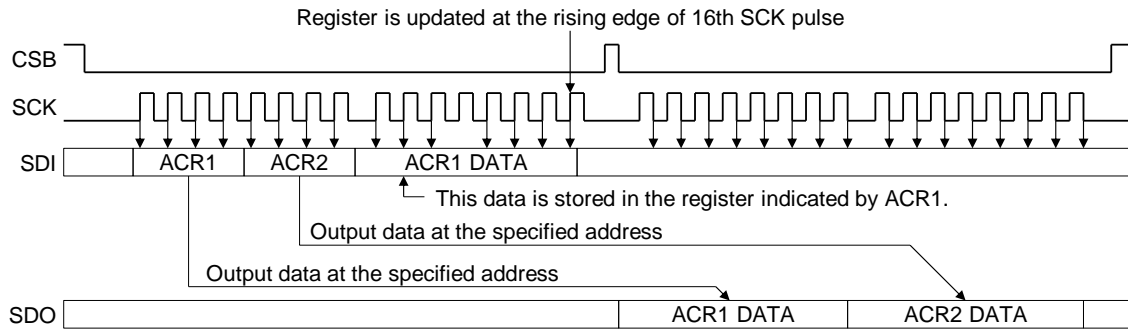

In reading data from Status Register, the address is indicated in the first 4 bits and the next 4 bits. It is not necessary to input values to the last 8 bits. Output data is output in 16 bit of the next frame from SDO. The data corresponding to the address indicated in the first 4 bits is output in the first 8 bits of the next frame. And the data corresponding to the address indicated in the next 4 bits is output in the last 8 bits of the next frame.

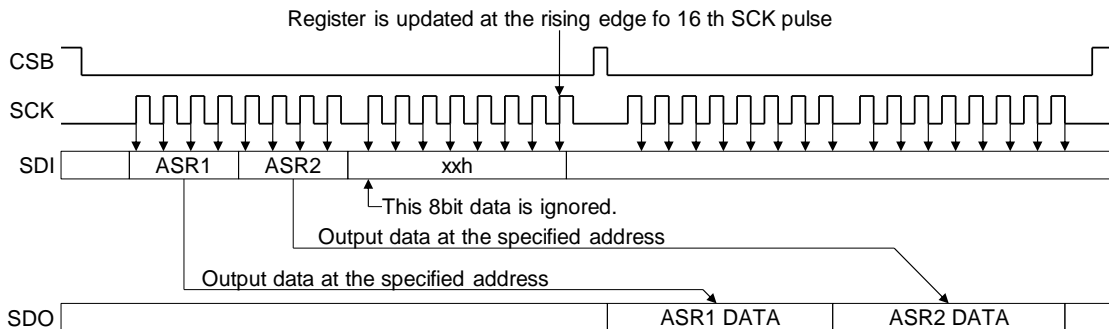

This IC supports a burst transfer. MCU can write data to registers continuously by inputting data in multiple of 16 to SCK and SDI with CSB = 'L'.

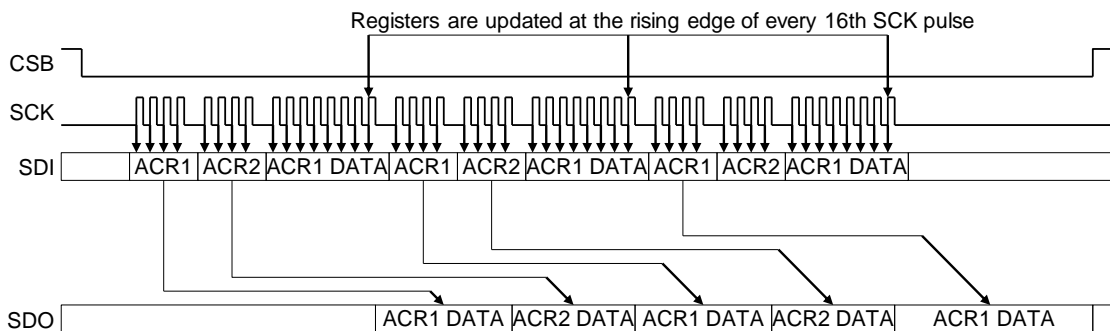

SPI Interface - continued

SPI Bit Count Error Detection

This IC supports SPI error check function. Then IC counts the SCK pulses during CSB = L and checks the count at the rising edge of CSB. If the count is not a multiple of 16, SPI bit count error is detected.
(If there are no SCK pulses during CSB = L, any SPI bit count errors are not detected because of no effect for register access.)

In case of single packet transfer

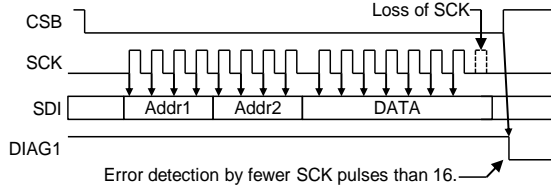

In case of burst transfer

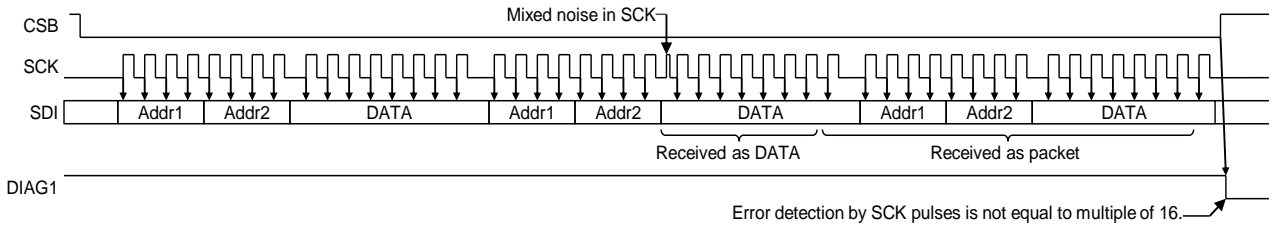

Multi IC connection example

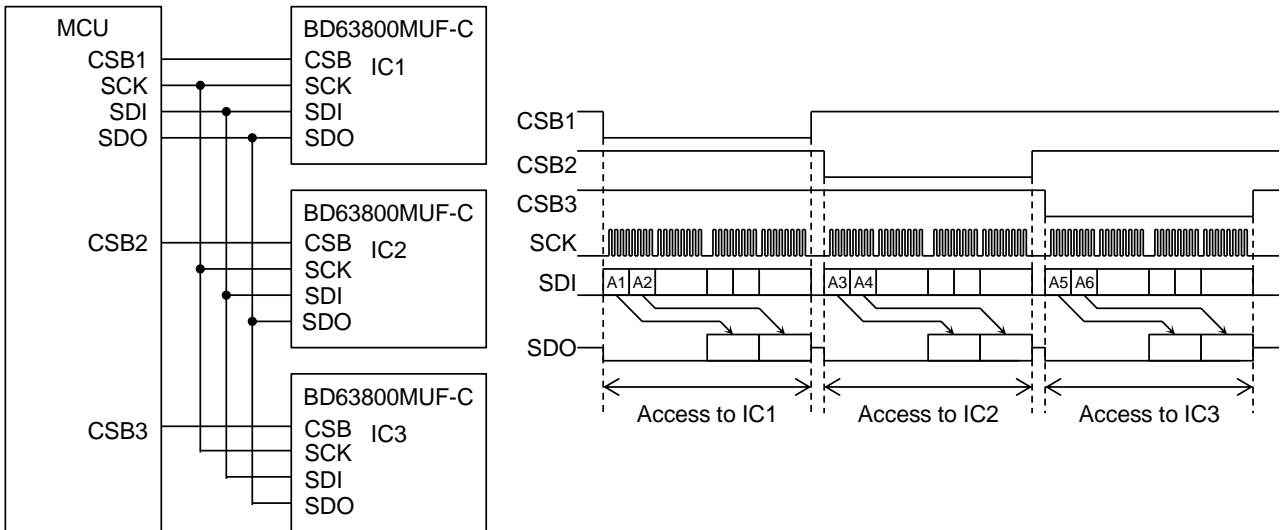

Figure 5. Example of Multi IC Connection

The Figure 5 shows the connection diagram and the access timing chart where three ICs are connected in parallel. The pins SCK, SDI, SDO can be shorted to each other. The MCU can select the specific IC to write to Control Register and to read from Status Register by controlling each CSB pin. The SDO pin is CMOS type. But it switches to HiZ state during CSB = H. Therefore, the MCU can read data from specific IC even if all SDOs are shorted. If the MCU send command two or more ICs at the same time, each IC may output different levels. Note that large current flows in the SDO pin in that case. Also, the MCU input from SDO becomes HiZ when CSB pins of all ICs are set to 'H'. Ensure that there is enough time of CSB = H so that each IC's output does not overlap. (Refer to $t_{DCSBSDO1}$, $t_{DCSBSDO2}$ in SPI timing table in [P41 Electrical Characteristics](#))

Function Description – continued

Protection/Detection Functions

Malfunction Prevention Function w/o Power Supply (Ghost Supply Prevention Function)

This function prevents IC malfunction when there is no power supplied to the IC and a control signal^(Note 1) is input to the IC. The voltage supplied to the power supply of this IC or other IC in the system is shorted through the electrostatic destruction prevention diode from these input pins to the VCC. Therefore, there is no malfunction of the circuit even when voltage is supplied to these input pins while there is no power supply.

(Note 1) control signal: Logic signals, MTH, RREF

Thermal Shutdown Function (TSD)

This IC has a built-in Thermal Shutdown circuit for protection against overheating. If the chip temperature of the IC is above +175 °C (Typ), the motor output will become open. It will automatically return to normal operation when the temperature goes below +150 °C (Typ). However, even when TSD is in operation, if heat is continuously applied externally, it will result in thermal runaway and can lead to destruction of the IC.

Thermal Warning Function (TW)

This IC has a built-in temperature warning circuit to detect overheating. When the chip temperature of the IC is above the level set by SPI, a temperature warning is output to the SDO and DIAG1/DIAG2 pins. The warning is cleared when temperature goes down under the level set by SPI. Unlike Thermal Shutdown Function (TSD), IC keeps the motor control operation even in Thermal Warning Function.

TWThr[3:0]	TW Threshold Level ON/OFF [°C] (Typ)		
0000	65.7	/	33.8
0001	71.4	/	39.8
0010	77.1	/	45.9
0011	82.8	/	51.9
0100	88.4	/	58.0
0101	94.1	/	64.0
0110	99.8	/	70.1
0111	105.4	/	76.1
1000	111.1	/	82.2
1001	116.8	/	88.2
1010	122.4	/	94.2
1011	128.1	/	100.3
1100	133.8	/	106.3
1101	139.5	/	112.4
1110	145.1	/	118.4
1111	150.8	/	124.5

Over Current Protection Function (OCP)

This IC has a built-in over current protection circuit as a countermeasure against destruction when the motor outputs are shorted to each other, to VCC or to GND. This circuit latches the motor output to open state when the current is above the specified level (reference value: 3 A in 25 °C, Typ) for 4 μs (Typ). The IC can only recover by power-on again or reset by the PSB pin.

The overcurrent protection circuit is designed to prevent the breakdown of IC caused by overcurrent in abnormal conditions such as shorted motor outputs. This protection is not intended to guarantee the protection of application circuit. Therefore, do not design the protection of the system using this circuit function. After detecting over current, then power-on again or recovery by reset while IC is still in abnormal state, the OCP operates repeatedly ('latch → recover → latch'). Note that the IC may generate heat and may lead to deterioration of the IC.

If the L value of the wiring is large, such as when the wiring during a shorted circuit to each other, to VCC or to GND is long, there is a possibility of destruction of the IC after the over current has flowed and the output pin voltage suddenly jumps to a value that is over the absolute maximum ratings.

If the current is below the OCP detection current level and above the output current rating level, the IC can heat up, exceed $T_{jmax} = 150\text{ °C}$ and then deteriorate, so current which exceeds the output rating should not be applied.

Over Voltage Lock-out Function (OVLO)

This IC has a built-in over voltage lock-out circuit to protect the IC output and the motor during power supply over voltage. When the applied voltage to the VCC pin goes up to 32 V (Typ) or more, the motor output is set to OPEN. To prevent false operation by noise, etc., the switching voltage has a 1 V (Typ) hysteresis and there is a 4 μs (Typ) mask time for the detection time

Although the overvoltage lock out circuit is built-in, there is a possibility of destruction if the absolute maximum value for power supply voltage is exceeded. Avoid to exceed the absolute maximum rating. Note that this circuit does not operate during power save state.

Protection/Detection Functions – continued

Under Voltage Lock-out (UVLO) / Under Voltage Motor Hold Function

This IC has a built-in under voltage lock-out circuit to prevent malfunction of IC output caused by low level power supply to IC. When the VCC pin is lower than the level set by SPI, IC set the motor output to open.

Under voltage motor hold mode can also be selected. In this mode, when IC detects low level of power supply, IC keeps motor hold although the detected results are output to DIAG1/DIAG2 and Status Register.

These modes can be selected by setting UVM3 to UVM0 in the control register.

UVM3	UVM2	UVM1	UVM0	Mode	Operation
0	0	0	0	Protection	Motor output: Open during low voltage in VCC
1	1	0	1	Hold	Motor output: Hold during low voltage in VCC
Others				Prohibited	_(Note 1)

(Note 1) In this mode, IC keeps the operation. But there is a possibility that the following status occurs. If each of protection/hold is set to UVM3 to UVM0, SDO output normally.

- SDO output unexpected logical value.
- Protection/Detection function are turned off.

This switching voltage has hysteresis to prevent false operation by noise etc. Note that this circuit does not operate during power save mode.

UVThr[3:0]	UV Threshold Level ON/OFF [V] (Typ)
0000	3.92 / 4.53
0001	4.29 / 4.96
0010	4.67 / 5.39
0011	5.04 / 5.82
0100	5.41 / 6.24
0101	5.78 / 6.67
0110	6.15 / 7.10
0111	6.52 / 7.53
1000	6.89 / 7.96
1001	7.26 / 8.39
1010	7.64 / 8.82
1011	8.01 / 9.24
1100	8.38 / 9.67
1101	8.75 / 10.10
1110	9.12 / 10.53
1111	9.49 / 10.96

Open Detection Function

This IC has a built-in open detection function.

It outputs open detection result to the SDO and DIAG1/DIAG2 pins when any of H-bridge output pins (OUT1A, OUT1B, OUT2A, and OUT2B) become open.

The open detection is asserted when the open status keeps over 5.12 ms (Typ). The open detection is not asserted in the following conditions because an internal timer counting the open period will be stopped. If the open state continues after recovering from the following conditions, the timer starts to count-up again and the open detection will be asserted.

(1) In detection of TSD, OCP, UVLO^(Note 1), OVLO

(2) In Hold mode with IHOLD = '0000'

(3) When Electric angle is 0°/180° (Stopping detection Only in OUT2 side), 90°/270° (Stopping detection Only in OUT1 side)

(Note 1) The open detection is available when under voltage motor hold mode is selected.

In case of fast motor rotation without chopping operation, the open status is detected even if the outputs are not open.

Protection/Detection Functions – continued

Stall Detection Function

This IC has a built-in stall detection circuit.

Stall is detected by monitoring the back electromotive voltages at zero cross points.

If the motor gets stalled, the IC outputs the Status register value from the SDO pin by SPI and Stall detection result from the DIAG1/DIAG2 pins.

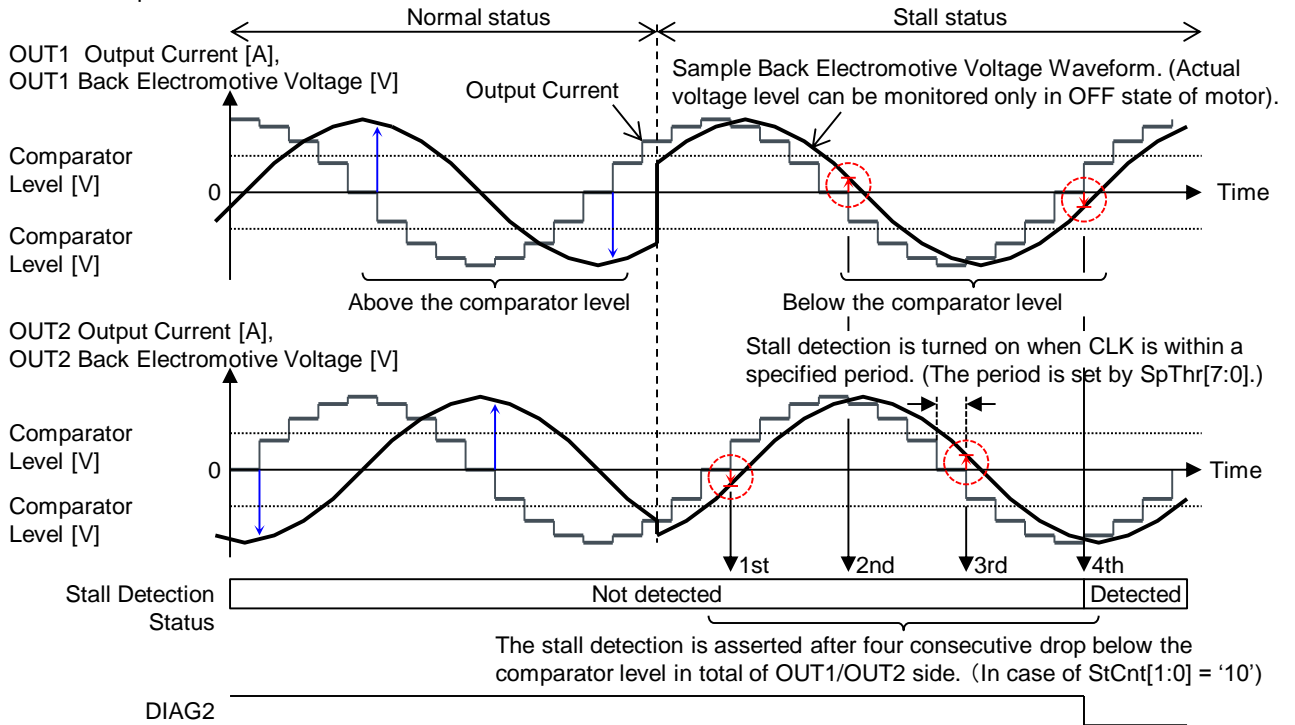

The stall detection is asserted after four consecutive drop below the comparator level in total of OUT1/OUT2 side. (In case of StCnt[1:0] = '10')

DIAG2

Comparator Voltage Level: Set StThr[7:0] and BeGain2/BeGain referring to the table below
Unit [V] (all values are typical)

StThr[7:0]	n	BeGain2/BeGain			
		'0'/'0'	'0'/'1'	'1'/'0'	'1'/'1'
0000 0000	0	Stall detection: Disabled			
0000 0001	1	0.20	0.15	0.06	0.03
0000 0010	2	0.39	0.29	0.12	0.06
0000 0011	3	0.59	0.44	0.18	0.09
0000 0100	4	0.78	0.59	0.24	0.12
:	:	:	:	:	:
1111 1110	254	49.80	37.35	14.94	7.47
1111 1111	255	50.00	37.50	15.00	7.50
Calculation Formula		$\frac{10}{51} \times n$	$\frac{5}{34} \times n$	$\frac{2}{34} \times n$	$\frac{1}{34} \times n$

Comparator Hysteresis: Hysteresis is the share for Comparator Voltage Level. Set StHys[3:0] referring to the table below.

StHys[3:0]	m	Hysteresis (Typ)
0000	0	4 %
0001	1	8 %
0010	2	12 %
:	:	:
1110	14	60 %
1111	15	64 %
Calculation Formula		$4 \times (m + 1)$

Stall Detection Function – continued

CLK-IN period condition where stall detection is enabled: Set SpThr[7:0] referring to the table below. Stall detection is enabled when CLK-IN period is less than or equal to the values in the table.

SpThr[7:0]	Threshold setting of CLK-IN Period for Stall detection (Typ)
0000 0000	Stall detection: Disabled
0000 0001	20 μ s
0000 0010	40 μ s
:	:
1111 1110	5,080 μ s
1111 1111	5,100 μ s

Total count of asserting Stall detection: Set StCnt[1:0] referring to the table below. Stall detection is asserted when the back electromotive voltage falls below the comparator level in consecutive certain times indicated in the table below.

StCnt[1:0]	Total times of stall status for asserting stall detection
00	1 time stall status
01	2 times consecutive stall status
10	4 times consecutive stall status
11	8 times consecutive stall status

Stall detection is available in 1/2, 1/4, 1/8, 1/16 and 1/32 step modes.

Protection/Detection Functions – continued**DIAG Output Selection Function**

This IC has DIAG output function.

The following detection results are output from the DIAG1/DIAG2 pins.

- (1) Over Current Detection
- (2) Open Detection
- (3) Thermal Warning (TW)
- (4) Thermal Shutdown (TSD)
- (5) Stall Detection
- (6) Under Voltage Detection
- (7) Over Voltage Detection
- (8) SPI Bit Count Error Detection

MCU can freely select detection/protection to output to the DIAG1 and DIAG2 pins by setting Control Register CR5A/CR6A. In the initial state after the IC resets, DIAG1 outputs logical OR of all detection results mentioned above and DIAG2 outputs only stall detection result. Refer to [P33 CR5A \(0x15\) CR6A \(0x16\)](#).

Function Description – continued

Control Register

Control Register Map

Values in the bottom row are the default value after reset

5-bit Address	Bit7	Bit6	Bit5	Bit4	Bit3	Bit2	Bit1	Bit0
01h(CR1)	CWBP	RHBP	CLKP	MOTEN	StThr7	StThr6	StThr5	StThr4
	0	0	0	0	0	0	0	0
02h(CR2)	IHOLD3	IHOLD2	IHOLD1	IHOLD0	IRUN3	IRUN2	IRUN1	IRUN0
	0	0	0	0	0	0	0	0
03h(CR3)	-	-	EMC1	EMC0	UVM3	SM2	SM1	SM0
	0	0	1	0	0	0	0	0
05h(CR5)	SpThr7	SpThr6	SpThr5	SpThr4	SpThr3	SpThr2	SpThr1	SpThr0
	0	0	0	0	0	0	0	0
06h(CR6)	UVThr3	UVThr2	UVThr1	UVThr0	-	-	-	-
	0	0	0	0	0	0	0	0
07h(CR7)	AD4	BeGain	UVM2	UVM1	-	-	-	-
	0	0	0	0	0	0	0	0
11h(CR1A)	UVM0	BeGain2	StCnt1	StCnt0	TwThr3	TwThr2	TwThr1	TwThr0
	0	0	0	1	0	0	0	0
12h(CR2A)	StHys3	StHys2	StHys1	StHys0	StThr3	StThr2	StThr1	StThr0
	0	0	0	0	0	0	0	0
15h(CR5A)	SelSPI1	SelSHORT1	SelOPEN1	SelTW1	SelTSD1	SelSTALL1	SelUV1	SelOV1
	1	1	1	1	1	1	1	1
16h(CR6A)	SelSPI2	SelSHORT2	SelOPEN2	SelTW2	SelTSD2	SelSTALL2	SelUV2	SelOV2
	0	0	0	0	0	1	0	0

Control Register - continued

Definition of each Control Register Bit

CR1 (0x01)

Symbol	Bit	Description
CWBP	7	Motor rotation direction selection. When CWBP = 1, the CWB pin logic is inverted. Refer to P7 CWB (Motor Rotation Direction Selection Pin)
RHBP	6	Drive/Hold mode selection. When RHBP = 1, the RHB pin logic is inverted. In RHB xor RHBP = 0, Hold mode is selected Refer to P7 RHB (Drive/Hold Mode Selection Pin)
CLKP	5	CLKIN input. It's recognized as CLKIN input to set '1' to this bit. Internally the value is cleared to '0' automatically after receiving next rising edge of SCK. (Note that the external CLK input is ignored during this period) Refer to P6 CLK (Clock Input Pin for Micro Step)
MOTEN	4	Enable of H-bridge. Motor driving operation starts after '1' is set to this bit. H-bridge is open after '0' is set to this bit. Refer to P13 Translator Circuit Operation
StThr[7:4]	[3:0]	Threshold setting for Stall detection. Stall detection is disabled in StThr[7:0]='0000 0000'. When other values are set, Stall detection is enabled. Refer to P27 Stall Detection Function

CR2 (0x02)

Symbol	Bit	Description
IHOLD[3:0]	[7:4]	Current ratio setting for the hold mode. Refer to P21 Drive Mode and Hold Mode
IRUN[3:0]	[3:0]	Current ratio setting for the drive mode. Refer to P21 Drive Mode and Hold Mode

CR3 (0x03)

Symbol	Bit	Description
EMC[1:0]	[5:4]	Switching slew rate setting for motor driver. '00': 12 V/μs, '01': 24 V/μs, '10': 96 V/μs, '11': 192 V/μs
SM[2:0]	[2:0]	Excitation mode selector. Refer to P6 MODE0, MODE1 (Motor Excitation Mode Selection Pin)
UVM3	3	Selection bit for Protection /Hold mode in Under Voltage state. Refer to P26 Under Voltage Lock-out (UVLO) / Under Voltage Motor Hold Function

CR5 (0x05)

Symbol	Bit	Description
SpThr[7:0]	[7:0]	Threshold setting of stepping speed for Stall detection. 1 step = 20 μs (Typ). Stall detection is enabled when the CLKIN period is smaller than this register. Stall detection is disabled in SpThr[7:0]='0000 0000'. Refer to P27 Stall Detection Function

CR6 (0x06)

Symbol	Bit	Description
UVThr[3:0]	[7:4]	Threshold setting for UVLO Refer to P26 Under Voltage Lock-out (UVLO) / Under Voltage Motor Hold Function

Definition of each Control Register Bit – continued

CR7 (0x07)

Symbol	Bit	Description
AD4	7	Address setting bit. AD4 = '0': Access to following registers is available. CR1, CR2, CR3, CR5, CR6, SR1, SR2, SR3, SR5 and SR6 AD4 = '1': Access to following registers is available. CR1A, CR2A, CR5A, CR6A, SR7A and SR8A Note that writing access to CR7 is available both in AD4 = '0'/'1' but reading access to CR7 is available only in AD4 = '0'.
BeGain	6	Gain setting for back electromotive voltage for Stall detection. Refer to P27 Stall Detection Function
UVM2, UVM1	[5:4]	Selection bit for Protection /Hold mode in Under Voltage state. Refer to P26 Under Voltage Lock-out (UVLO) / Under Voltage Motor Hold Function

CR1A (0x11)

Symbol	Bit	Description
UVM0	7	Selection bit for Protection /Hold mode in Under Voltage state. Refer to P26 Under Voltage Lock-out (UVLO) / Under Voltage Motor Hold Function
BeGain2	6	Gain setting for back electromotive voltage for Stall detection. Refer to P27 Stall Detection Function
StCnt[1:0]	[5:4]	Counter setting for Stall detection. Refer to P27 Stall Detection Function
TwThr[3:0]	[3:0]	Threshold setting for Thermal warning Refer to P25 Thermal Warning Function (TW)

CR2A (0x12)

Symbol	Bit	Description
StHys[3:0]	[7:4]	Hysteresis setting for Stall detection. Refer to P27 Stall Detection Function
StThr[3:0]	[3:0]	Threshold setting for Stall detection. Refer to P27 Stall Detection Function

Definition of each Control Register Bit – continued

CR5A (0x15)

Symbol	Bit	Description
SelSPI1	7	DIAG1 output selector for SPI bit count error detection result '1': the detection result output to DIAG1. Refer to P29 DIAG Output Selection Function.
SelSHORT1	6	DIAG1 output selector for Over current protection '1': the detection result output to DIAG1. Refer to P29 DIAG Output Selection Function.
SelOPEN1	5	DIAG1 output selector for Open detection result '1': the detection result output to DIAG1. Refer to P29 DIAG Output Selection Function.
SelTW1	4	DIAG1 output selector for Thermal warning (TW) '1': the detection result output to DIAG1. Refer to P29 DIAG Output Selection Function.
SelTSD1	3	DIAG1 output selector for Thermal shutdown (TSD) '1': the detection result output to DIAG1. Refer to P29 DIAG Output Selection Function.
SelSTALL1	2	DIAG1 output selector for Stall detection result '1': the detection result output to DIAG1. Refer to P29 DIAG Output Selection Function.
SelUV1	1	DIAG1 output selector for Under voltage detection result '1': the detection result output to DIAG1. Refer to P29 DIAG Output Selection Function.
SelOV1	0	DIAG1 output selector for Over voltage detection result '1': the detection result output to DIAG1. Refer to P29 DIAG Output Selection Function.

CR6A (0x16)

Symbol	Bit	Description
SelSPI2	7	DIAG2 output selector for SPI bit count error detection result '1': the detection result output to DIAG2. Refer to P29 DIAG Output Selection Function.
SelSHORT2	6	DIAG2 output selector for Over current protection '1': the detection result output to DIAG2. Refer to P29 DIAG Output Selection Function.
SelOPEN2	5	DIAG2 output selector for Open detection result '1': the detection result output to DIAG2. Refer to P29 DIAG Output Selection Function.
SelTW2	4	DIAG2 output selector for Thermal warning (TW) '1': the detection result output to DIAG2. Refer to P29 DIAG Output Selection Function.
SelTSD2	3	DIAG2 output selector for Thermal shutdown (TSD) '1': the detection result output to DIAG2. Refer to P29 DIAG Output Selection Function.
SelSTALL2	2	DIAG2 output selector for Stall detection result '1': the detection result output to DIAG2. Refer to P29 DIAG Output Selection Function.
SelUV2	1	DIAG2 output selector for Under voltage detection result '1': the detection result output to DIAG2. Refer to P29 DIAG Output Selection Function.
SelOV2	0	DIAG2 output selector for Over voltage detection result '1': the detection result output to DIAG2. Refer to P29 DIAG Output Selection Function.

Function Description – continued

Status Register

Status Register Map

Values in the bottom row are the default value after reset

5-bit Address	Bit7	Bit6	Bit5	Bit4	Bit3	Bit2	Bit1	Bit0
08h(SR1) Errors1	PAR	SPI	SHORT	OPEN	TSD	TW	STALL	Reserved
	0	0	0	0	0	0	0	0
09h(SR2) Errors2	PAR	ORErr	OV	UV	Reserved	Reserved	Reserved	Reserved
	0	0	0	0	0	0	0	0
0Ah(SR3) Position	PAR	MSP6	MSP5	MSP4	MSP3	MSP2	MSP1	MSP0
	0	0	0	0	0	0	0	0
0Ch(SR5) Speed	Sp7	Sp6	Sp5	Sp4	Sp3	Sp2	Sp1	Sp0
	0	0	0	0	0	0	0	0
0Dh(SR6) StepLoss	PAR	SI6	SI5	SI4	SI3	SI2	SI1	SI0
	0	0	0	0	0	0	0	0
1Eh(SR7A) In&Short1	PAR	OPEN1	MODE0pin	MODE1pin	SHRT1AB	SHRT1BB	SHRT1AT	SHRT1BT
	0	0	0	0	0	0	0	0
1Fh(SR8A) In&Short2	PAR	OPEN2	RHBpin	CWBpin	SHRT2AB	SHRT2BB	SHRT2AT	SHRT2BT
	0	0	0	0	0	0	0	0

Status Register - continued

Definition of each Status Register Bit

SR1 (0x08)

Symbol	Bit	Description
PAR	7	Parity bit for Status Register SR1. PAR value is calculated so that total of '1' in SR1 is even.
SPI	6	SPI input bit count check result. '1' is set when total bit number during CSB = 'L' is not multiple of 16. This bit is cleared by setting CLKP = '0' and MOTEN = '1' in CR1. Refer to P24 SPI Bit Count Error Detection .
SHORT	5	OCP detection status. '1' is set when over current status is detected. This bit is cleared by PSB = L or VCC power down. SR7A[3:0] and SR8A[3:0] show the positions where over current actually flows. Refer to P25 Over Current Protection Function (OCP) .
OPEN	4	Open detection status. '1' is set when the open status is detected. This bit is cleared by setting CLKP = '0' and MOTEN = '1' in CR1. SR7A[6] and SR8A[6] show which of OUT1/OUT2 is open. Refer to P26 Open Detection Function .
TSD	3	Thermal shutdown status. '1' is set when TSD is detected. This bit is cleared by setting CLKP = '0' and MOTEN = '1' in CR1. Refer to P25 Thermal Shutdown Function (TSD) .
TW	2	Thermal warning status. '1' is set when temperature of IC chip is over the threshold set by SPI. This bit is cleared by setting CLKP = '0' and MOTEN = '1' in CR1. Refer to P25 Thermal Warning Function (TW) .
STALL	1	Stall detection status. '1' is set when stall is detected. This bit is cleared by setting CLKP = '0' and MOTEN = '1' in CR1. Refer to P27 Stall Detection Function .

SR2 (0x09)

Symbol	Bit	Description
PAR	7	Parity bit for Status Register SR2. PAR value is calculated so that total of '1' in SR2 is even.
ORErr	6	OR output of bit 6 to bit0 in SR1
OV	5	Over voltage lock-out status. '1' is set when 'over voltage' is detected. This bit is cleared by setting CLKP = '0' and MOTEN = '1' in CR1. Refer to P25 Over Voltage Lock-out Function (OVLO) .
UV	4	Under voltage lock-out status. '1' is set when 'under voltage' is detected. This bit is cleared by setting CLKP = '0' and MOTEN = '1' in CR1. Refer to P26 Under Voltage Lock-out (UVLO) / Under Voltage Motor Hold Function .

Definition of each Status Register Bit – continued

SR3 (0x0A)

Symbol	Bit	Description
PAR	7	Parity bit for Status Register SR3. PAR value is calculated so that total of '1' in SR3 is even.
MSP[6:0]	[6:0]	Micro step position. MSP is updated by CLK-IN input based on the excitation mode and CW setting. But MSP is not updated when CLK-IN is input during TSD, OCP, OVLO, UVLO and Open detection because the motor is turned off. And MSP is also not updated in the hold mode (including under voltage motor hold mode.) where CLK-IN is ignored. Refer to P16 Step Sequence

SR5 (0x0C)

Symbol	Bit	Description
Sp[7:0]	[7:0]	CLK-IN stepping period. Sp shows the period between the rising edge of last two CLK-IN. 1 step is 20 us (Typ) and the maximum period is 5.1 ms (Typ) at Sp[7:0] = '1111 1111'. IC keeps the maximum value if the period is longer than it.

SR6 (0x0D)

Symbol	Bit	Description
PAR	7	Parity bit for Status Register SR6. PAR value is calculated so that total of '1' in SR6 is even.
SI[6:0]	[6:0]	Step Loss Counter. IC counts CLK-IN input while the motor is in open state by TSD/OCP/UVLO/OVLO. The maximum number is 127 pulses (SI[6:0] = '111 1111'). IC keeps the maximum value if more CLK-IN pulses are input. In the hold mode where CLK-IN is no available, SI is not updated even in the protected state. This bit is cleared by setting CLKP = '0' and MOTEN = '1' in CR1.

Definition of each Status Register Bit – continued

SR7A (0x1E)

Symbol	Bit	Description
PAR	7	Parity bit for Status Register SR7A. PAR value is calculated so that total of '1' in SR7A is even.
OPEN1	6	Output of Open detection result for OUT1. '1' is set when the open status is detected. This bit goes back '0' when the open state is cleared.
MODE0pin	5	Output of the MODE0 pin logic level
MODE1pin	4	Output of the MODE1 pin logic level
SHRT1AB	3	Short status of OUT1A - GND. '1' is set when the short status is detected. This bit is cleared by PSB = L or VCC power down.
SHRT1BB	2	Short status of OUT1B - GND. '1' is set when the short status is detected. This bit is cleared by PSB = L or VCC power down.
SHRT1AT	1	Short status of OUT1A - VCC. '1' is set when the short status is detected. This bit is cleared by PSB = L or VCC power down.
SHRT1BT	0	Short status of OUT1B - VCC. '1' is set when the short status is detected. This bit is cleared by PSB = L or VCC power down.

SR8A (0x1F)

Symbol	Bit	Description
PAR	7	Parity bit for Status Register SR8A. PAR value is calculated so that total of '1' in SR8A is even.
OPEN2	6	Output of Open detection result for OUT2. '1' is set when the open status is detected. This bit goes back '0' when the open state is cleared.
RHBpin	5	Output of the RHB pin logic level
CWBpin	4	Output of the CWB pin logic level
SHRT2AB	3	Short status of OUT2A - GND. '1' is set when the short status is detected. This bit is cleared by PSB = L or VCC power down.
SHRT2BB	2	Short status of OUT2B - GND. '1' is set when the short status is detected. This bit is cleared by PSB = L or VCC power down.
SHRT2AT	1	Short status of OUT2A - VCC. '1' is set when the short status is detected. This bit is cleared by PSB = L or VCC power down.
SHRT2BT	0	Short status of OUT2B - VCC. '1' is set when the short status is detected. This bit is cleared by PSB = L or VCC power down.

Power-on Sequence

To initialize this IC completely in power-on, follow the sequences shown below.

$t_1 > 1 \mu\text{s}$, $t_2 > 0 \mu\text{s}$, $t_4 > 0 \mu\text{s}$ (all Typ). Refer to [P14 Control Input Timing](#) for t_3 and t_5 .

If $t_1 > 1 \mu\text{s}$ is not satisfied, there is a possibility that IC is not initialized completely because of no power-on reset operation by steep rise of VCC. In that case, PSB should be set to GND level once after the rise of VCC.

Case of power-on with PSB = L

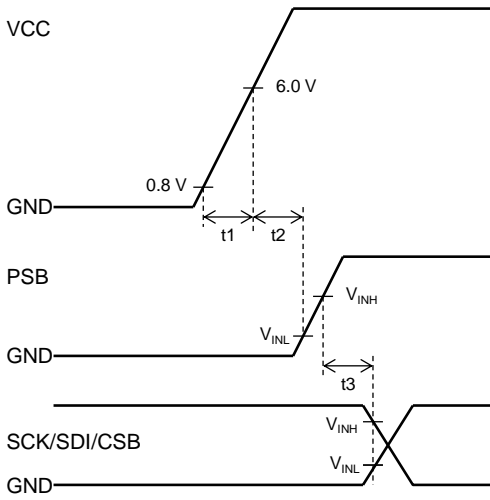

Case of power-on with PSB = H

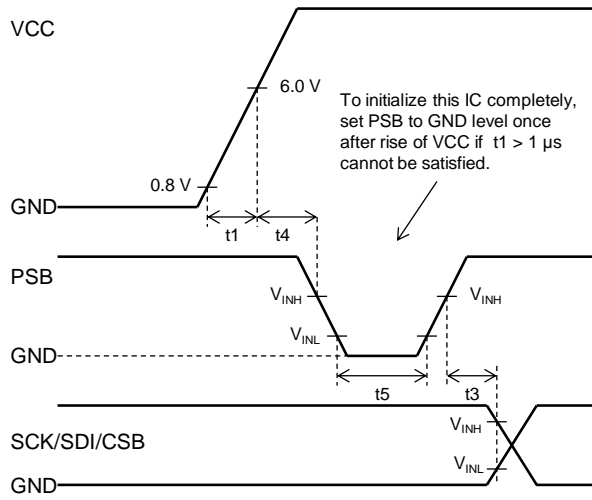

Power Dissipation

In consideration of the IC's power consumption (W), thermal resistance (θ_{JA}), and ambient temperature (T_a), confirm that the IC's chip temperature T_j is not over 150 °C. When $T_j = 150$ °C is exceeded, the functions as a semiconductor do not operate and problems such as parasitism and leaks occur. Constant use under these circumstances leads to deterioration and eventually destruction of the IC. $T_{jmax} = 150$ °C must be strictly obeyed under all circumstances.

Thermal Calculation

The power consumption of this IC can be estimated roughly. The calculation formula in case of Full step mode in slow decay mode is shown below:

Self-power consumption in V_{CC} :

$$V_{CC} \times I_{CC} \quad [W] \quad (1)$$

Output DMOS power consumption during output ON:

$$(R_{ONH} + R_{ONL}) \times I_{OUT}^2 \times 2 \times on_duty \quad [W] \quad (2)$$

Output DMOS power consumption during decay:

$$2 \times R_{ONL} \times I_{OUT}^2 \times 2 \times (1 - on_duty) \quad [W] \quad (3)$$

IC total power consumption:

$$W_{TOTAL} = (1) + (2) + (3) \quad [W]$$

Junction temperature:

$$T_j = T_a + \theta_{JA} \times W_{TOTAL} \quad [^{\circ}C]$$

Where

V_{CC} is the power supply voltage [V].

I_{CC} is the circuit current [A] without motor load.

I_{OUT} is the motor output current [A].

R_{ONH} is the Upper Pch DMOS ON Resistance [Ω]. 0.45 Ω in BD63800MUF-C (Typ).

R_{ONL} is the Lower Nch DMOS ON Resistance [Ω]. 0.30 Ω in BD63800MUF-C (Typ).

$$on_duty = \frac{t_{ON}}{t_{CHOP}}$$

t_{CHOP} is the chopping cycle time [s], which depends on the CR pin. Refer [P10 PWM Constant Current control](#) for details.

t_{ON} is the CR charging period during t_{CHOP} [s], which depends on the L and R values of the motor coil and the current setting. Confirm by actual measurement, or make an approximate calculation.

T_a is the ambient temperature [$^{\circ}C$].

θ_{JA} is the thermal resistance from junction to ambient [$^{\circ}C/W$].

Note that the thermal resistance value θ_{JA} [$^{\circ}C/W$] differs greatly depending on circuit board conditions. ROHM provides a service to measure the thermal resistance θ_{JA} with a PCB which customers actually designed. Contact us about this service. The calculated values above are only theoretical. For actual thermal design, perform sufficient thermal evaluation for the application board used, and make the thermal design with enough margin so as not to exceed $T_{jmax} = 150$ °C.

Consider attaching an external Schottky diode between the motor output pin and the GND pin / the VCC pin to abate heat from the IC if the IC is used under particularly severe heat conditions. (This counter measure is not necessary for normal use)

Absolute Maximum Rating

(Ta = 25 °C)

Item	Symbol	Rated Value	Unit
Supply Voltage	V _{CC}	-0.2 to +40.0	V
Input Voltage for Control Pin	V _{IN}	-0.2 to +7.0	V
Output Voltage for Control Pin	V _{OUT}	-0.2 to +7.0	V
Output Current (Steady-state)	I _{OUT}	1.21 ^(Note 1)	A/Phase
Output Current (Peak) ^(Note 2)	I _{OUTPEAK}	1.35 ^(Note 1)	A/Phase
Storage Temperature Range	T _{stg}	-55 to +150	°C
Maximum Junction Temperature	T _{jmax}	+150	°C

(Note 1) Do not exceed T_{jmax} = 150 °C.*(Note 2)* Pulse width tw ≤ 1 ms, duty 20 %

Caution 1: Operating the IC over the absolute maximum ratings may damage the IC. The damage can either be a short circuit between pins or an open circuit between pins and the internal circuitry. Therefore, it is important to consider circuit protection measures, such as adding a fuse, in case the IC is operated over the absolute maximum ratings.

Caution 2: Should by any chance the maximum junction temperature rating be exceeded the rise in temperature of the chip may result in deterioration of the properties of the chip. In case of exceeding this absolute maximum rating, design a PCB with thermal resistance taken into consideration by increasing board size and copper area so as not to exceed the maximum junction temperature rating.

Recommended Operating Condition

Item	Symbol	Min	Typ	Max	Unit
Operating Temperature	Topr	-40	+25	+125	°C
Supply Voltage	V _{CC}	6.0	12.0	28.0	V

Thermal Resistance *(Note 1)*

Parameter	Symbol	Thermal Resistance (Typ)		Unit
		1s ^(Note 3)	2s2p ^(Note 4)	
VQFN32FBV050				
Junction to Ambient	θ _{JA}	89.20	30.80	°C/W
Junction to Top Characterization Parameter ^(Note 2)	Ψ _{JT}	10.00	7.00	°C/W

(Note 1) Based on JESD51-2A (Still-Air).*(Note 2)* The thermal characterization parameter to report the difference between junction temperature and the temperature at the top center of the outside surface of the component package.*(Note 3)* Using a PCB board based on JESD51-3.*(Note 4)* Using a PCB board based on JESD51-5, 7.

Layer Number of Measurement Board	Material	Board Size
Single	FR-4	114.3 mm x 76.2 mm x 1.57 mmt

Top	
Copper Pattern	Thickness
Footprints and Traces	70 μm

Layer Number of Measurement Board	Material	Board Size	Thermal Via ^(Note 5)	
			Pitch	Diameter
4 Layers	FR-4	114.3 mm x 76.2 mm x 1.6 mmt	1.20 mm	Φ0.30 mm

Top		2 Internal Layers		Bottom	
Copper Pattern	Thickness	Copper Pattern	Thickness	Copper Pattern	Thickness
Footprints and Traces	70 μm	74.2 mm x 74.2 mm	35 μm	74.2 mm x 74.2 mm	70 μm

(Note 5) This thermal via connects with the copper pattern of all layers.

Electrical Characteristics(Unless otherwise specified $V_{CC} = 8.0\text{ V}$ to 28.0 V , $T_a = -40\text{ }^\circ\text{C}$ to $+125\text{ }^\circ\text{C}$)

Item	Symbol	Limit			Unit	Conditions
		Min	Typ	Max		
Whole						
Standby Circuit Current	I_{CCST}	-	0.1	10.0	μA	PSB = L
Circuit Current	I_{CC}	-	3.5	-	mA	PSB = H, RREF = 6.2 k Ω
Control input (CLK, CWB, MODE0, MODE1, RHB, PSB, SCK, SDI, CSB)						
H Level Input Voltage	V_{INH}	2.0	-	-	V	
L Level Input Voltage	V_{INL}	-	-	0.8	V	
H Level Input Current	I_{INH}	35	50	100	μA	$V_{IN} = 5.0\text{ V}$
L Level Input Current	I_{INL}	-10	0	-	μA	$V_{IN} = 0.0\text{ V}$
Output(OUT1A, OUT1B, OUT2A, OUT2B)						
Output On Resistance	R_{ON}	-	0.75	1.50	Ω	$I_{OUT} = \pm 0.5\text{ A}$, Total of upper and lower side
Output Leakage Current	I_{LEAK}	-	0.1	10.0	μA	
Output Rising Slew Rate	t_R	-	2.0	-	μs	$V_{CC} = 24\text{ V}$
Output Falling Slew Rate	t_F	-	2.0	-	μs	EMC[1:0] = '00'
Current Control Unit						
Maximum Output Current	I_{OMAX}	0.99	1.10	1.21	A	RREF = 6.2 k Ω
PWM Frequency	f_{PWM}	-	25.0	-	kHz	C = 1000 pF, R = 39 k Ω
RREF Outflow Current	I_{RREF}	-	74	-	μA	RREF = 6.2 k Ω
RREF Output Voltage	V_{RREF}	-	0.457	-	V	
MTH Input Current	I_{MTH}	-10	-5	-	μA	MTH = 0 V
MTH Input Voltage Range	V_{MTH}	0	-	3.5	V	
Minimum ON Time (Blank Time)	t_{ONMIN}	0.3	0.8	1.5	μs	C = 1000 pF, R = 39 k Ω
DIAG Output (DIAG1, DIAG2)						
Output L Voltage	V_{OLD}	-	0.15	0.50	V	$I_{LOAD} = -1\text{ mA}$
Output Leakage Current	I_{OD}	-	0	10	μA	$V_{DG} = 5\text{ V}$
SDO Output						
Output H Voltage	V_{OHS}	4.50	4.85	-	V	$I_{LOAD} = +1\text{ mA}$
Output L Voltage	V_{OLS}	-	0.15	0.50	V	$I_{LOAD} = -1\text{ mA}$
Output Leakage Current	I_{OS}	-	0	10	μA	$V_{SDO} = 5\text{ V}$
Protection circuit						
Thermal Shutdown ON Temperature	T_{TSDON}	-	175.0	-	$^\circ\text{C}$	
Thermal Shutdown OFF Temperature	T_{TSDOFF}	-	150.0	-	$^\circ\text{C}$	
Thermal Warning ON Ambient Temp	T_{TAON}	-	150.8	-	$^\circ\text{C}$	TWThr = '1111'
Thermal Warning OFF Ambient Temp	T_{TAOFF}	-	124.5	-	$^\circ\text{C}$	TWThr = '1111'
Low Voltage Protection ON Voltage	V_{UVON}	-	5.04	-	V	UVThr = '0011'
Low Voltage Protection OFF Voltage	V_{UVOFF}	-	5.82	-	V	UVThr = '0011'
Over Voltage Protection ON Voltage	V_{OVON}	-	32.0	-	V	
Over Voltage Protection OFF Voltage	V_{OVOFF}	-	31.0	-	V	
Output Load Open Detection Time	t_{LOPEN}	-	5.12	-	ms	

Electrical Characteristics - continued

(Unless otherwise specified $V_{CC} = 8.0\text{ V}$ to 28.0 V , $T_a = -40\text{ }^\circ\text{C}$ to $+125\text{ }^\circ\text{C}$)

Item	Symbol	Specification			Unit	Conditions
		Min	Typ	Max		
SPI Timing						
SPI Clock Cycle	t_{SCK}	1	-	-	μs	
SPI Clock High Time Range	t_{HSCK}	200	-	-	ns	
SPI Clock Rise Time	t_{RSCK}	-	-	1	μs	
SPI Clock Fall Time	t_{FSCK}	-	-	1	μs	
SPI Clock Low Time Range	t_{LSCK}	200	-	-	ns	
SDI Setup Time for SCK	t_{STSDI}	50	-	-	ns	
SDI Hold Time for SCK	t_{HDSDI}	50	-	-	ns	
CSB High Time	t_{HCSB}	200	-	-	ns	
CSB Low Setup Time for SCK	t_{STLCSB}	1	-	-	μs	
CSB High Hold Time for SCK	t_{HDHCSB}	200	-	-	ns	
SDO Delay Time for CSB Rising Edge	$t_{DCSBSDO1}$	-	-	250	ns	$R_L = 1.5\text{ k}\Omega$, $C_L = 10\text{ pF}$
SDO Delay Time for CSB Falling Edge	$t_{DCSBSDO2}$	-	-	250	ns	$R_L = 1.5\text{ k}\Omega$, $C_L = 10\text{ pF}$
SDO Delay Time for SCK	$t_{DSCKSDO}$	-	-	100	ns	$R_L = 1.5\text{ k}\Omega$, $C_L = 10\text{ pF}$

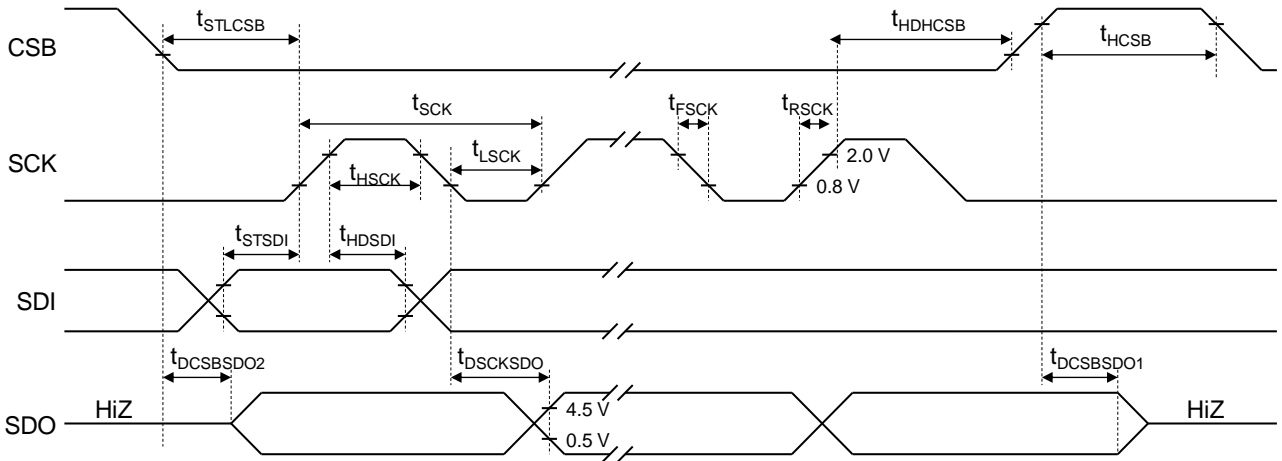

Figure 6. SPI Timing Chart

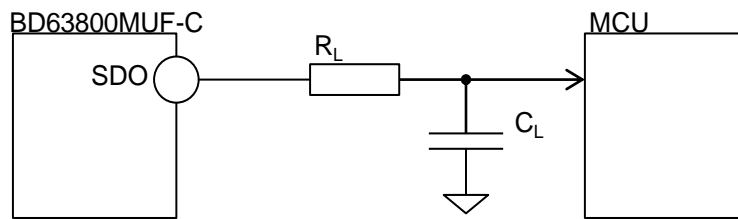
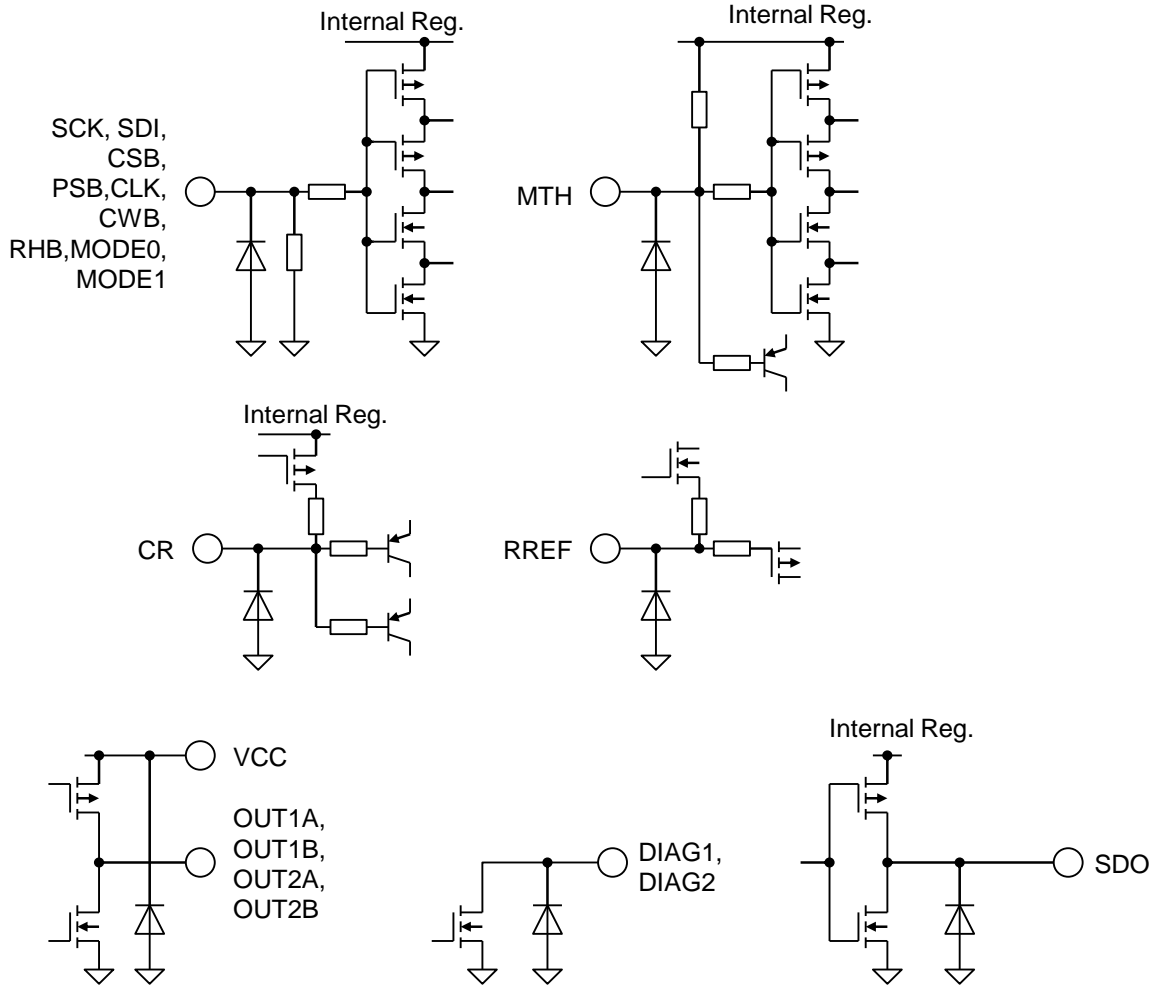

Figure 7. SDO Load Model

I/O Equivalence Circuit



Operational Notes

1. Reverse Connection of Power Supply

Connecting the power supply in reverse polarity can damage the IC. Take precautions against reverse polarity when connecting the power supply, such as mounting an external diode between the power supply and the IC's power supply pins.

2. Power Supply Lines

Design the PCB layout pattern to provide low impedance supply lines. Furthermore, connect a capacitor to ground at all power supply pins. Consider the effect of temperature and aging on the capacitance value when using electrolytic capacitors.

3. Ground Voltage

Ensure that no pins are at a voltage below that of the ground pin at any time, even during transient condition.

4. Ground Wiring Pattern

When using both small-signal and large-current ground traces, the two ground traces should be routed separately but connected to a single ground at the reference point of the application board to avoid fluctuations in the small-signal ground caused by large currents. Also ensure that the ground traces of external components do not cause variations on the ground voltage. The ground lines must be as short and thick as possible to reduce line impedance.

5. Recommended Operating Conditions

The function and operation of the IC are guaranteed within the range specified by the recommended operating conditions. The characteristic values are guaranteed only under the conditions of each item specified by the electrical characteristics.

6. Inrush Current

When power is first supplied to the IC, it is possible that the internal logic may be unstable and inrush current may flow instantaneously due to the internal powering sequence and delays, especially if the IC has more than one power supply. Therefore, give special consideration to power coupling capacitance, power wiring, width of ground wiring, and routing of connections.

7. Testing on Application Boards

When testing the IC on an application board, connecting a capacitor directly to a low-impedance output pin may subject the IC to stress. Always discharge capacitors completely after each process or step. The IC's power supply should always be turned off completely before connecting or removing it from the test setup during the inspection process. To prevent damage from static discharge, ground the IC during assembly and use similar precautions during transport and storage.

8. Inter-pin Short and Mounting Errors

Ensure that the direction and position are correct when mounting the IC on the PCB. Incorrect mounting may result in damaging the IC. Avoid nearby pins being shorted to each other especially to ground, power supply and output pin. Inter-pin shorts could be due to many reasons such as metal particles, water droplets (in very humid environment) and unintentional solder bridge deposited in between pins during assembly to name a few.

9. Unused Input Pins

Input pins of an IC are often connected to the gate of a MOS transistor. The gate has extremely high impedance and extremely low capacitance. If left unconnected, the electric field from the outside can easily charge it. The small charge acquired in this way is enough to produce a significant effect on the conduction through the transistor and cause unexpected operation of the IC. So unless otherwise specified, unused input pins should be connected to the power supply or ground line.

Operational Notes – continued

10. Regarding the Input Pin of the IC

This monolithic IC contains P+ isolation and P substrate layers between adjacent elements in order to keep them isolated. P-N junctions are formed at the intersection of the P layers with the N layers of other elements, creating a parasitic diode or transistor. For example (refer to figure below):

- When $GND > Pin\ A$ and $GND > Pin\ B$, the P-N junction operates as a parasitic diode.
- When $GND > Pin\ B$, the P-N junction operates as a parasitic transistor.

Parasitic diodes inevitably occur in the structure of the IC. The operation of parasitic diodes can result in mutual interference among circuits, operational faults, or physical damage. Therefore, conditions that cause these diodes to operate, such as applying a voltage lower than the GND voltage to an input pin (and thus to the P substrate) should be avoided.

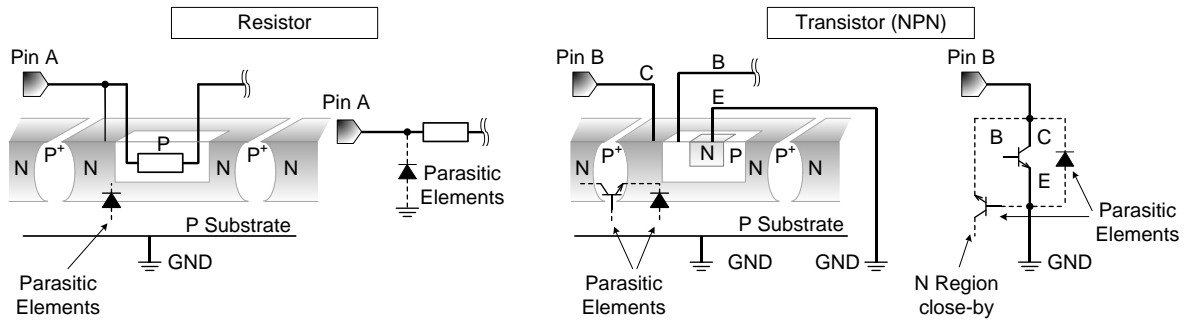

Figure 8. Example of Monolithic IC Structure

11. Ceramic Capacitor

When using a ceramic capacitor, determine a capacitance value considering the change of capacitance with temperature and the decrease in nominal capacitance due to DC bias and others.

12. Thermal Shutdown Circuit (TSD)

This IC has a built-in thermal shutdown circuit that prevents heat damage to the IC. Normal operation should always be within the IC's maximum junction temperature rating. If however the rating is exceeded for a continued period, the junction temperature (T_j) will rise which will activate the TSD circuit that will turn OFF power output pins. When the T_j falls below the TSD threshold, the circuits are automatically restored to normal operation.

Note that the TSD circuit operates in a situation that exceeds the absolute maximum ratings and therefore, under no circumstances, should the TSD circuit be used in a set design or for any purpose other than protecting the IC from heat damage.

13. Over Current Protection Circuit (OCP)

This IC incorporates an integrated overcurrent protection circuit that is activated when the load is shorted. This protection circuit is effective in preventing damage due to sudden and unexpected incidents. However, the IC should not be used in applications characterized by continuous operation or transitioning of the protection circuit.

Ordering Information

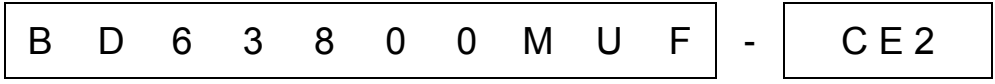

Package
MUF: VQFN32FBV050

Product Rank
C: for Automotive
Packaging and forming specification
E2: Embossed tape and reel

Marking Diagram

VQFN32FBV050 (TOP VIEW)

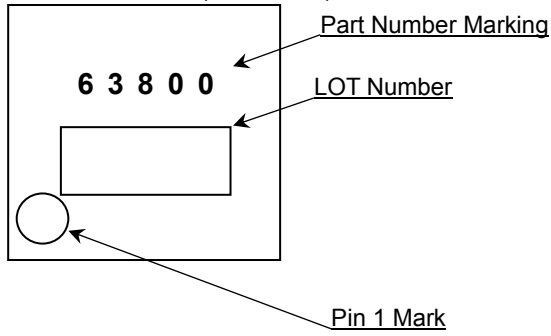

Revision History

Date	Revision	Changes
10.Feb.2021	001	The first edition

Notice

Precaution on using ROHM Products

1. If you intend to use our Products in devices requiring extremely high reliability (such as medical equipment ^(Note 1), aircraft/spacecraft, nuclear power controllers, etc.) and whose malfunction or failure may cause loss of human life, bodily injury or serious damage to property ("Specific Applications"), please consult with the ROHM sales representative in advance. Unless otherwise agreed in writing by ROHM in advance, ROHM shall not be in any way responsible or liable for any damages, expenses or losses incurred by you or third parties arising from the use of any ROHM's Products for Specific Applications.

(Note1) Medical Equipment Classification of the Specific Applications

JAPAN	USA	EU	CHINA
CLASS III	CLASS III	CLASS II b	CLASS III
CLASS IV		CLASS III	

2. ROHM designs and manufactures its Products subject to strict quality control system. However, semiconductor products can fail or malfunction at a certain rate. Please be sure to implement, at your own responsibilities, adequate safety measures including but not limited to fail-safe design against the physical injury, damage to any property, which a failure or malfunction of our Products may cause. The following are examples of safety measures:
 - [a] Installation of protection circuits or other protective devices to improve system safety
 - [b] Installation of redundant circuits to reduce the impact of single or multiple circuit failure
3. Our Products are not designed under any special or extraordinary environments or conditions, as exemplified below. Accordingly, ROHM shall not be in any way responsible or liable for any damages, expenses or losses arising from the use of any ROHM's Products under any special or extraordinary environments or conditions. If you intend to use our Products under any special or extraordinary environments or conditions (as exemplified below), your independent verification and confirmation of product performance, reliability, etc, prior to use, must be necessary:
 - [a] Use of our Products in any types of liquid, including water, oils, chemicals, and organic solvents
 - [b] Use of our Products outdoors or in places where the Products are exposed to direct sunlight or dust
 - [c] Use of our Products in places where the Products are exposed to sea wind or corrosive gases, including Cl₂, H₂S, NH₃, SO₂, and NO₂
 - [d] Use of our Products in places where the Products are exposed to static electricity or electromagnetic waves
 - [e] Use of our Products in proximity to heat-producing components, plastic cords, or other flammable items
 - [f] Sealing or coating our Products with resin or other coating materials
 - [g] Use of our Products without cleaning residue of flux (Exclude cases where no-clean type fluxes is used. However, recommend sufficiently about the residue.); or Washing our Products by using water or water-soluble cleaning agents for cleaning residue after soldering
 - [h] Use of the Products in places subject to dew condensation
4. The Products are not subject to radiation-proof design.
5. Please verify and confirm characteristics of the final or mounted products in using the Products.
6. In particular, if a transient load (a large amount of load applied in a short period of time, such as pulse, is applied, confirmation of performance characteristics after on-board mounting is strongly recommended. Avoid applying power exceeding normal rated power; exceeding the power rating under steady-state loading condition may negatively affect product performance and reliability.
7. De-rate Power Dissipation depending on ambient temperature. When used in sealed area, confirm that it is the use in the range that does not exceed the maximum junction temperature.
8. Confirm that operation temperature is within the specified range described in the product specification.
9. ROHM shall not be in any way responsible or liable for failure induced under deviant condition from what is defined in this document.

Precaution for Mounting / Circuit board design

1. When a highly active halogenous (chlorine, bromine, etc.) flux is used, the residue of flux may negatively affect product performance and reliability.
2. In principle, the reflow soldering method must be used on a surface-mount products, the flow soldering method must be used on a through hole mount products. If the flow soldering method is preferred on a surface-mount products, please consult with the ROHM representative in advance.

For details, please refer to ROHM Mounting specification

Precautions Regarding Application Examples and External Circuits

1. If change is made to the constant of an external circuit, please allow a sufficient margin considering variations of the characteristics of the Products and external components, including transient characteristics, as well as static characteristics.
2. You agree that application notes, reference designs, and associated data and information contained in this document are presented only as guidance for Products use. Therefore, in case you use such information, you are solely responsible for it and you must exercise your own independent verification and judgment in the use of such information contained in this document. ROHM shall not be in any way responsible or liable for any damages, expenses or losses incurred by you or third parties arising from the use of such information.

Precaution for Electrostatic

This Product is electrostatic sensitive product, which may be damaged due to electrostatic discharge. Please take proper caution in your manufacturing process and storage so that voltage exceeding the Products maximum rating will not be applied to Products. Please take special care under dry condition (e.g. Grounding of human body / equipment / solder iron, isolation from charged objects, setting of Ionizer, friction prevention and temperature / humidity control).

Precaution for Storage / Transportation

1. Product performance and soldered connections may deteriorate if the Products are stored in the places where:
 - [a] the Products are exposed to sea winds or corrosive gases, including Cl₂, H₂S, NH₃, SO₂, and NO₂
 - [b] the temperature or humidity exceeds those recommended by ROHM
 - [c] the Products are exposed to direct sunshine or condensation
 - [d] the Products are exposed to high Electrostatic
2. Even under ROHM recommended storage condition, solderability of products out of recommended storage time period may be degraded. It is strongly recommended to confirm solderability before using Products of which storage time is exceeding the recommended storage time period.
3. Store / transport cartons in the correct direction, which is indicated on a carton with a symbol. Otherwise bent leads may occur due to excessive stress applied when dropping of a carton.
4. Use Products within the specified time after opening a humidity barrier bag. Baking is required before using Products of which storage time is exceeding the recommended storage time period.

Precaution for Product Label

A two-dimensional barcode printed on ROHM Products label is for ROHM's internal use only.

Precaution for Disposition

When disposing Products please dispose them properly using an authorized industry waste company.

Precaution for Foreign Exchange and Foreign Trade act

Since concerned goods might be fallen under listed items of export control prescribed by Foreign exchange and Foreign trade act, please consult with ROHM in case of export.

Precaution Regarding Intellectual Property Rights

1. All information and data including but not limited to application example contained in this document is for reference only. ROHM does not warrant that foregoing information or data will not infringe any intellectual property rights or any other rights of any third party regarding such information or data.
2. ROHM shall not have any obligations where the claims, actions or demands arising from the combination of the Products with other articles such as components, circuits, systems or external equipment (including software).
3. No license, expressly or implied, is granted hereby under any intellectual property rights or other rights of ROHM or any third parties with respect to the Products or the information contained in this document. Provided, however, that ROHM will not assert its intellectual property rights or other rights against you or your customers to the extent necessary to manufacture or sell products containing the Products, subject to the terms and conditions herein.

Other Precaution

1. This document may not be reprinted or reproduced, in whole or in part, without prior written consent of ROHM.
2. The Products may not be disassembled, converted, modified, reproduced or otherwise changed without prior written consent of ROHM.
3. In no event shall you use in any way whatsoever the Products and the related technical information contained in the Products or this document for any military purposes, including but not limited to, the development of mass-destruction weapons.
4. The proper names of companies or products described in this document are trademarks or registered trademarks of ROHM, its affiliated companies or third parties.

General Precaution

1. Before you use our Products, you are requested to carefully read this document and fully understand its contents. ROHM shall not be in any way responsible or liable for failure, malfunction or accident arising from the use of any ROHM's Products against warning, caution or note contained in this document.
2. All information contained in this document is current as of the issuing date and subject to change without any prior notice. Before purchasing or using ROHM's Products, please confirm the latest information with a ROHM sales representative.
3. The information contained in this document is provided on an "as is" basis and ROHM does not warrant that all information contained in this document is accurate and/or error-free. ROHM shall not be in any way responsible or liable for any damages, expenses or losses incurred by you or third parties resulting from inaccuracy or errors of or concerning such information.