



Product Change Notification / SYST-09QLBY018

Date:

11-Nov-2021

Product Category:

PoE PD

PCN Type:

Document Change

Notification Subject:

Data Sheet - PD70101/PD70201 Datasheet

Affected CPNs:

[SYST-09QLBY018_Affected_CPN_11112021.pdf](#)

[SYST-09QLBY018_Affected_CPN_11112021.csv](#)

Notification Text:

SYST-09QLBY018

Microchip has released a new Product Documents for the PD70101/PD70201 Datasheet of devices. If you are using one of these devices please read the document located at [PD70101/PD70201 Datasheet](#).

Notification Status: Final

Description of Change: The following is the summary of changes in this revision. 1) Updated the figure and table in the 4. Package Specifications section. 2) Updated the 5. Recommended PCB Layout section.

Impacts to Data Sheet: None

Reason for Change: To Improve Productivity

Change Implementation Status: Complete

Date Document Changes Effective: 11 Nov 2021

NOTE: Please be advised that this is a change to the document only the product has not been changed.

Markings to Distinguish Revised from Unrevised Devices: N/A

Attachments:

[PD70101/PD70201 Datasheet](#)

Please contact your local [Microchip sales office](#) with questions or concerns regarding this notification.

Terms and Conditions:

If you wish to receive Microchip PCNs via email please register for our PCN email service at our [PCN home page](#) select register then fill in the required fields. You will find instructions about registering for Microchips PCN email service in the [PCN FAQ](#) section.

If you wish to change your PCN profile, including opt out, please go to the [PCN home page](#) select login and sign into your myMicrochip account. Select a profile option from the left navigation bar and make the applicable selections.

Affected Catalog Part Numbers (CPN)

PD70101ILQ-TR

PD70201ILQ-TR



PD70101 and PD70201

PoE IEEE® 802.3af/at PD Controller

Introduction

The PD70101 and PD70201 devices are integrated Powered Device (PD) interface and PWM controllers for a DC-DC converter used in IEEE® 802.3af and IEEE® 802.3at applications. The PD70101 device can be used for IEEE 802.3af or IEEE 802.3at Type 1 applications, while the PD70201 device can also be used in IEEE 802.3at Type 2 applications.

A single PD70201 device can be used in 4-pair applications that consume up to 47.7 W.

These devices have a number of features designed to improve efficiency and reliability:

- **Detection and Classification:** The front-end interface includes detection and classification circuitry. The detection signature resistor is disconnected upon completion of the detection phase. The system then begins the classification phase. Classification can be configured for Classes 0 to 4 via an external resistor. The PD70201 includes a two-events classification identification circuit, which generates a flag to inform the PD application whether the Power Source Equipment (PSE) is Type 1 or Type 2.
- **Capacitor:** A current-limited internal MOSFET switch charges the input capacitor of the DC-DC converter. This capacitor is discharged in a timely manner when the input power is removed.
- **Gate drivers:** The PWM DC-DC controller has two built-in gate drivers designed to swing between VCC and GND. These two out-of-phase driver stages can be configured for synchronous rectification or active clamp.
- **Peak current mode control:** The DC-DC converter employs peak current mode control for better line and load step response. The switching frequency can be set from 100 kHz to 500 kHz, enabling a size and efficiency trade off.
- **Maximum duty cycle** is limited to 50% to reduce the power MOSFET switch voltage to two times the input voltage; a 150V rated MOSFET can be used for the primary side switch. The secondary synchronous MOSFET voltage rating depends on the output voltage and can be higher or lower than the primary side MOSFET switch.
- **Soft-Start circuit:** The devices include a soft-start circuit to control the output voltage rise time (user settable) at start-up, and to limit the inrush current. An integrated startup bias circuit powers the DC-DC controller, until the device starts up by the voltage generated by the bootstrap circuit.
- **Low Voltage Protection Warning and Monitoring:** Dual Under Voltage Lock Out (UVLO), which monitors both the PoE Port Input Voltage and VCC, ensures reliable operation during any system disturbances. The PoE port UVLO has a programmable threshold and hysteresis to enable tailoring to the desired turn-on and turn-off voltage.

An internal current sense amplifier with a Kelvin connection allows the use of an extremely low resistor to measure the current sense threshold voltage (200 mV) which optimizes efficiency.

Low Power Mode operation is provided to improve efficiency under light loads such as when the PD is in standby. The user can define at what power level the unit enters low power mode by means of a single resistor value.

Features

The following is a list of features that are supported in this device.

- Designed to support IEEE 802.3af and IEEE 802.3at standards.
- PD Detection and Programmable Classification Signature
- Two-Events Classification Flag
- Signature Resistor Disconnection after Detection
- Integrated 0.6 Ω Isolating Switch and Inrush Current Limiter
- 4-Pairs support with a single PD70201 IC for up to 48 W
- 4-Pairs support with two PD70201 ICs for up to 96 W
- Less than 10 μ A Offset Current during Detection
- Single DC Voltage Input (36 V – 57 V)
- Wide Operating Temperature Range: -40 to 85 °C
- On-Chip Thermal Protection
- Integrated PWM - 100 kHz to 500 kHz adjustable DC-DC switching frequency DC-DC frequency can be synchronized to external clock
- Supports low power mode operation for higher efficiency
 - 50% maximum duty cycle
 - Soft-start circuit to control the output voltage rise time
- Two out-of-phase driver stages for efficient synchronous rectification or active clamp
- PoE port input UVLO with programmable threshold and hysteresis
- Internal differential amplifier simplifying non-isolated step down converter
- Over load and short circuit protection
- 32-Pin 5 mm x 5 mm QFN Package
- RoHS Compliant
- MSL3

The following table lists the Microchip PD products offerings.

Table 1. Microchip Powered Device Products Offerings

Part	Type	Package	IEEE 802.3af	IEEE 802.3at	HDBaseT (PoH)	UPoE
PD70100	Front end	3 mm × 4 mm 12L DFN	x	—	—	—
PD70101	Front end + PWM	5 mm × 5 mm 32L QFN	x	—	—	—
PD70200	Front end	3 mm × 4 mm 12L DFN	x	x	—	—
PD70201	Front end + PWM	5 mm × 5 mm 32L QFN	x	x	—	—
PD70210	Front end	4 mm × 5 mm 16L DFN	x	x	x	x
PD70210A	Front end	4 mm × 5 mm 16L DFN	x	x	x	x
PD70210AL	Front end	5 mm × 7 mm 38L QFN	x	x	x	x
PD70211	Front end + PWM	6 mm × 6 mm 36L QFN	x	x	x	x
PD70224	Ideal diode bridge	6 mm × 8 mm 40L QFN	x	x	x	x

Table of Contents

Introduction.....	1
Features.....	2
Applications.....	3
1. Functional Descriptions.....	6
2. Electrical Specifications.....	7
2.1. Absolute Maximum Ratings.....	7
2.2. Thermal Specifications.....	7
2.3. Electrical Characteristics.....	8
3. Pin Configuration.....	15
4. Package Specifications.....	18
5. Recommended PCB Layout.....	20
6. Theory of Operation.....	22
6.1. Detection.....	22
6.2. Physical Layer Classification.....	22
6.3. Two-Events Detection and AT Flag.....	22
6.4. Soft Start and Inrush Current Protection.....	23
6.5. Over-Current Protection.....	23
6.6. Power Good.....	24
6.7. Start-Up Supply.....	24
6.8. PD Interface Thermal Protection.....	24
6.9. Bulk Capacitor Discharge.....	24
6.10. DC-DC Start-Up.....	24
6.11. Current Limit and Short Circuit Protection.....	25
6.12. Low Power Mode Operation.....	25
6.13. Input (VPP and VCC) Under Voltage Lock Out.....	25
6.14. External Enable.....	25
7. Ordering Information.....	26
8. Reference Documents.....	27
9. Revision History.....	28
The Microchip Website.....	29
Product Change Notification Service.....	29
Customer Support.....	29
Microchip Devices Code Protection Feature.....	29
Legal Notice.....	29
Trademarks.....	30

Quality Management System.....	30
Worldwide Sales and Service.....	31

1. Functional Descriptions

The following figure shows the functional block diagram of PD70101/PD70201 device.

Figure 1-1. Functional Block Diagram

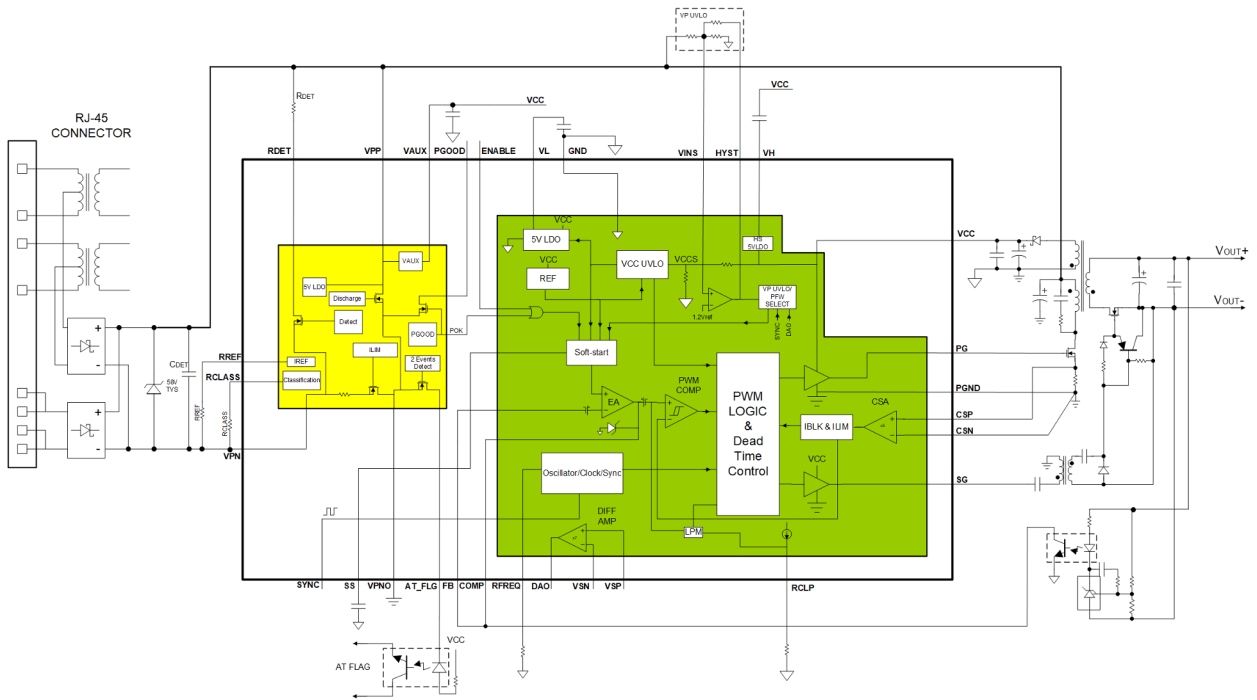

2. Electrical Specifications

The following section describes the electrical specifications of the PD70101/PD70201 device.

2.1 Absolute Maximum Ratings

The following table lists the absolute maximum ratings of the PD70101/PD70201 device.

Table 2-1. Absolute Maximum Ratings

Parameter	Value	Units
VPP, RDET, VPN_OUT (with respect to VPN_IN)	-0.3 to 74	V _{DC}
RREF, RCLASS (with respect to VPN_IN)	-0.3 to 6	V
PGOOD, AT_FLAG, VAUX (with respect to VPN_OUT)	-0.3 to 74	V
VCC (with respect to PGND)	-0.3 to 40	V _{DC}
PG, SG (with respect to PGND)	-0.3 to 20	V _{DC}
VL, VSN, VSP (with respect to PGND)	-0.3 to 6	V
VH (with respect to VCC)	-0.3 to VCC-6	V _{DC}
All Other Pins (with respect to GND)	-0.3 to VL +0.3	V _{DC}
ESD (HBM) Protection at all I/O pins ¹	±1	kV
Maximum Junction Temperature (T _{JMAX})	150	°C
Operational Ambient Temperature	-40 to 85	°C
Storage Temperature Range	-65 to 150	°C
Peak Package Solder Re-flow Temperature (40 seconds maximum exposure), MSL3	260	°C

Note:

1. All pins except pin 2 (PGOOD) and pin 31 (VAUX). Pin 2 and 31 ESD Protection is ±150 V HBM.

Exceeding these ratings might cause damage to the device. All voltages are with respect to VPN_IN. Currents are positive into, negative out of specified terminal. These are stress ratings only and functional operation of the device at these or any other conditions beyond those indicated under Recommended Operating Conditions are not implied. Exposure to Absolute Maximum Ratings for extended periods may affect device reliability.

2.2 Thermal Specifications

The following table lists the thermal specifications of the PD70101/PD70201 device.

Table 2-2. Thermal Properties

Symbol	Thermal Resistance	Min	Type	Max	Units
θ _{JC}	Junction to case		5		°C/W
θ _{JP}	Junction to pad		4		°C/W
θ _{JA}	Junction to ambient		23		°C/W

Note: The θ_{Jx} numbers assume no forced airflow. Junction temperature is calculated using $T_J = T_A + (P_D \times \theta_{JA})$. In particular, θ_{JA} is a function of the PCB construction. The stated number above is for a four-layer board in accordance with JESD-51 (JEDEC) with thermal vias.

2.3 Electrical Characteristics

This section describes the electrical characteristics of the PD70101/PD70201 device.

The following specifications apply over the operating ambient temperature of $-40\text{ }^{\circ}\text{C} \leq T_A \leq 85\text{ }^{\circ}\text{C}$ (except where otherwise noted with $V_{PP} = 48\text{ V}$; $V_{EN} = \text{HIGH}$, $F_{\text{FREQ}} = 250\text{ kHz}$). Production tests were performed at $25\text{ }^{\circ}\text{C}$. Unless otherwise specified, V_{PP} is with respect to V_{PN_IN} and V_{CC} is with respect to PGND .

Table 2-3. PD Interface

Symbol	Parameter	Test Conditions/ Comment	Min	Type	Max	Units
Power Supply						
V_{PP}	Input voltage		0	55	57	V
Detection Mode						
DET_{RANGE}	Detection voltage range	Measured between V_{PP} and V_{PN_IN}	1.3		10.1	V
$R_{\text{DET-ON}}$	Detection switch ON resistance	$2.5\text{ V} \leq (\Delta V_{PP} \text{ to } V_{PN_IN}) \leq 10.1\text{ V}$ Measured between R_{DET} and V_{PN_IN}			50	Ω
$V_{\text{DET-OFF}}$	Detection is disconnected	Measured between V_{PP} and V_{PN_IN}	10.1		12.8	V
$R_{\text{DET-OFF}}$	Detection switch OFF resistance	$12.8\text{ V} \leq (\Delta V_{PP} \text{ to } V_{PN_IN}) \leq 57.0\text{ V}$ Measured between R_{DET} and V_{PN_IN}	2.0			$\text{M}\Omega$
I_{OFFSET}	Input offset current	$2.5\text{ V} \leq V_{PP} \leq 10.1\text{ V}$ $-40\text{ }^{\circ}\text{C} \leq T_J \leq 85\text{ }^{\circ}\text{C}$			16	μA
I_{OFFSET}		$2.5\text{ V} \leq V_{PP} \leq 10.1\text{ V}$ $-40\text{ }^{\circ}\text{C} \leq T_J \leq 55\text{ }^{\circ}\text{C}$			10	μA
$V_{\text{RDET-ON}}$	RDET reconnection level	Measured between V_{PP} and V_{PN_IN}	1.95	3.0	4.85	V
Classification Mode						

PD70101 and PD70201

Electrical Specifications

.....continued						
Symbol	Parameter	Test Conditions/ Comment	Min	Type	Max	Units
V _{TH-LOW-ON}	Classification current source, turn ON threshold range measured at V _{PP}	Turn on for any I _{CLASS} while V _{PP} increases	11.4		13.7	V
V _{HST}	Classification disconnection minimum hysteresis voltage	Hysteresis between V _{TH-low-on} and V _{TH-low-off}		1		V
V _{TH-HIGH-OFF}	Classification current source, turn OFF threshold range measured at V _{PP}	Turn off while V _{PP} increases	20.9		23.9	V
I _{CLASS-LIM}	Current limit threshold		50	68	80	mA
I _{CLASS-DIS}	Input current IPP when classification function is disabled	Class 0 R _{CLASS} = Open			3.0	mA
I _{CLASS-EN}	Input current IPP when classification function is enabled	Class 1 R _{CLASS} = 133 Ω ± 1%	9.5	10.5	11.5	mA
		Class 2 R _{CLASS} = 69.8 Ω ± 1%	17.5	18.5	19.5	mA
		Class 3 R _{CLASS} = 45.3 Ω ± 1%	26.5	28.0	29.5	mA
		Class 4 R _{CLASS} = 30.9 Ω ± 1%	38.0	40.0	42.0	mA
	R _{CLASS} Voltage		1.142		1.278	V
Mark						
V _{MARK}	Mark, working range	V _{PP} falling edge	4.9		10.1	V
I _{MARK}	Mark current		0.25		4	mA

PD70101 and PD70201

Electrical Specifications

Table 2-4. Isolation Switch

Symbol	Parameter	Test Conditions/Comment	Min	Type	Max	Units
V _{SW-START}	Isolation Switch MOSFET switches from off to I _{LIM-LOW}		36		42	V
V _{SW-OFF}	Isolation Switch MOSFET switched off		30.5		34.5	V
I _{LIM-LOW}	Startup current limit, I _{LIM-LOW}		130	240	330	mA
V _{DIFF}	VPN_IN to VPN_OUT Threshold voltage for I _{LIM-LOW} to I _{LIM-HIGH} switchover	When VPNIN to VPNOOUT ≤ VDIFF, Isolating switch switches over from I _{LIM-LOW} to I _{LIM-HIGH}			0.7	V
OCP	Over current protection limit current		1500	1800	2000	mA
I _{LOAD}	Continuous operation load	Isolating switch at I _{LIM-HIGH} PD70101			450	mA
		PD70201			1123	mA
SW-RDS _{ON}	Isolated Switch On resistance at I _{LIM-HIGH}	Total resistance between VPNIN and VPNOOUT Isolating switch at I _{LIM-HIGH}			0.6	Ω

Table 2-5. DC/DC Capacitor Discharge

Symbol	Parameter	Test Conditions/Comment	Min	Type	Max	Units
CIN	DC/DC input capacitance	For reference only Guaranteed by design (not tested in production)		220	264	μF
	Discharge current	7.0 V ≤ VPP to VPNOOUT ≤ 30 V	22.8	32	50	mA
AT_FLAG						
	Output low voltage	IOL = 0.75 mA			0.4	V
		IOL = 5 mA			2.5	V
	Leakage current	VAT_FLAG = 57 V			1.7	μA
PGOOD						
	Output low voltage	IOL = 0.75 mA			0.4	V
		IOL MAX = 5 mA			2.5	V
	Leakage current	VPGOOD = 57 V			1.7	μA
Interface Thermal Shutdown						
	Thermal Shutdown Temperature ¹		180	200	220	°C
VAUX (respect to VPN_OUT)						
VAUX-OFF	VAUX output voltage off (leakage current)	PGOOD = High impedance Load = 1 MΩ			1	V
VAUX-ON	VAUX output voltage on	Isolating switch at I _{LIM-HIGH} and PGOOD = Low	9.8	10.5	11.8	V
I _{VAUXP}	Output current peak	Capacitor = 30 μF When T _{LOAD} ≤ 5 ms Isolating switch at I _{LIM-HIGH} and PGOOD = Low	0		10	mA

PD70101 and PD70201

Electrical Specifications

.....continued

Symbol	Parameter	Test Conditions/Comment	Min	Type	Max	Units
I_{VAUXC}	Output continuous current	When $T_{LOAD} \leq 10$ mS Isolating switch at $I_{LIM-HIGH}$ and $PGOOD = Low$	0		2	mA
I_{VAUX}	VAUX output current limit	Isolating switch at $I_{LIM-HIGH}$ and $PGOOD = Low$	10		32	mA

Table 2-6. DC/DC Controller

Symbol	Parameter	Test Conditions/Comment	Min	Typ	Max	Units
VCC						
VCC	Maximum Input Operating Voltage				20	V
IVCC	Input Current	$VCC < VCC_{UVLO}$ or $ENABLE = Low$. ⁵		250	2000	μA
		V_{ENABLE} and $VINS = High$; $V_{VCC} < VCC_{UVLO_UP}$; $-40\text{ }^{\circ}C \leq$ $Temp \leq +55\text{ }^{\circ}C$. ⁵			4.5	mA
		$VCC > VCC_{UVLO}$ and $ENABLE = High$, No Load on PG, SG, VL, and FSW = 500 kHz.			3	mA
VCC_UVLO	VCC UVLO Rising Threshold	VCC raising edge	8.85	9.15	9.5	V
VCC_UVLO	VCC UVLO Falling Threshold	VCC falling edge	7	7.3	7.6	V
POE Port Input UVLO						
VINS	UVLO Threshold		1.171	1.200	1.229	V
	VINS Input Current		-0.1		0.1	μA
HYST- V_{OH}	HYST Output High Voltage	$I_{SOURCE} = 1$ mA	2.8			V
HYST- V_{OL}	HYST Output Low Voltage	$I_{SINK} = 3$ mA			0.4	V
Internal LDO's						
VL	5 V LDO	$IL < 5$ mA	4.75	5	5.25	V
VH	-5 V LDO	Reference to VCC		-5		V
Soft-Start						
I_{SS_CHG}	Soft-start charging current ²	$R_{FREQ} = 33.2$ k Ω ; $V_{SOFTSTART} = 0.5$ V	32	36	40	μA
I_{SS_DIS}	Soft-start discharging current	$V_{SOFTSTART} = 0.5$ V; % of I_{SS_CHG}		10		%
V_{SS_CH}	Soft-start completion threshold ¹	% of 1.2 V	90		95	%
V_{SS_DISCH}	Soft-start discharge completion threshold ¹			50		mV
R_{SS_DISCH}	Soft-start discharge FET on resistance			50		Ω
t_{DISCH}	Soft-start discharge FET on time ¹	1 cyc = $1/F_{FREQ}$		32		cyc

PD70101 and PD70201

Electrical Specifications

.....continued

Symbol	Parameter	Test Conditions/Comment	Min	Typ	Max	Units
Switching Frequency and Synchronization						
F _{FREQ}	Switching frequency range		100		500	kHz
F _{FREQ}	Switching frequency accuracy ³	R _{FREQ} = 33.2k	285	315	345	kHz
F _{SYNC}	Synchronization frequency range	F _{SYNC} > 2x F _{FREQ}	200		1000	kHz
V _{SYNC-HIGH}	Synchronization voltage high threshold		2.4		5	V
V _{SYNC-LOW}	Synchronization voltage low threshold				0.8	V
PW _{SYNC_MIN}	Synchronization minimum pulse width		100			ns
PW _{SYNC_MAX}	Synchronization maximum PWM duty				90	%
I _{SYNC}	Synchronization input current		-1.3		1.3	μA

Table 2-7. Error Amplifier

Symbol	Parameter	Test Conditions/Comment	Min	Type	Max	Units
Gain _{DC_OPL}	DC Open Loop Gain ¹	R _{LOAD} = 100k	70	100		dB
AV _{UGBW}	Unity Gain Bandwidth ¹	C _{LOAD} = 10 pF	2	5		MHz
I _{COMP_OUT}	Output Sourcing Current	0.2 V ≤ V _{COMP} ≤ 1.3 V	110		620	μA
I _{COMP_IN}	Output Sink Current	0.2 V ≤ V _{COMP} ≤ 1.3 V	145		495	μA
V _{EA_CM}	Input Common Mode Range		0		2	V
V _{FB}	Feedback Voltage	COMP shorted to FB	1.171	1.200	1.229	V
I _{FB}	FB Pin Input Current		-50		50	nA
V _{COMP}	Output Clamp Voltage		1.8	2.1	2.6	V

Table 2-8. PWM Comparator

Symbol	Parameter	Test Conditions/Comment	Min	Type	Max	Units
V _{RCLP}	RCLP Voltage Range		0		1	V
Low Power Mode (Skip Pulse Mode)						
	Low Power Skip	V _{COMP} Rising (% of V _{RCLP})		95		%
	Mode Threshold ^{1,4}	V _{COMP} Falling (% of V _{RCLP})		90		%

PD70101 and PD70201

Electrical Specifications

Table 2-9. Current Sense Amplifier and Current Limit

Symbol	Parameter	Test Conditions/ Comment	Min	Type	Max	Units
Gain _{CSA}	Gain	Measure at DC	4.75	5.0	5.25	V/V
V _{CSA_CMR}	Input Common Mode Range		0		2.0	V
	Output Rise/ Fall time ¹	10% to 90%			75	ns
t _{BLANK}	Blanking Time ¹		50		100	ns
V _{ILIM_TH}	Current Limit Threshold		1.1	1.2	1.3	V
V _{IMAX_TH}	Current Maximum Threshold		1.7	1.8	1.9	V

Table 2-10. Differential Amplifier

Symbol	Parameter	Test Conditions/ Comment	Min	Type	Max	Units
Gain _{DA}	Gain	Measured at DC	6.86	7.0	7.14	V/V
A _{V_UGBW_DA}	Unity Gain Bandwidth ¹			5		MHz
V _{DA_CMR}	Common Mode Range		0		3.5	V
	Input Offset Voltage		-7		7	mV
	Input Bias Current		-1		1	μA

Table 2-11. Output Drivers

Symbol	Parameter	Test Conditions/ Comment	Min	Type	Max	Units
PG R _{dsONH}	Primary Gate (PG) High On Resistance			10		Ω
PG R _{dsONL}	Primary Gate (PG) Low On Resistance			5		Ω
SG R _{dsONH}	Secondary Gate (SG) High On Resistance			10		Ω

PD70101 and PD70201

Electrical Specifications

.....continued

Symbol	Parameter	Test Conditions/ Comment	Min	Type	Max	Units
SG Rds _{ONL}	Secondary Gate (SG) Low On Resistance			10		Ω
T _{DEAD}	Dead Time – PG low to SG high or SG low to PG high	CLOAD on PG and SG = 1000 pF		110		ns
	PG Minimum On Time				120	ns
	PG Maximum Duty Cycle		44.5		50	%

Table 2-12. Logic (ENABLE Pin)

Symbol	Parameter	Test Conditions/ Comment	Min	Type	Max	Units
V _{HI}	Logic High Threshold		2.0			V
V _{LO}	Logic Low Threshold				0.8	V
	Input Current		-1		1	μA

Table 2-13. PWM Controller Thermal Shutdown

Symbol	Parameter	Test Conditions/ Comment	Min	Type	Max	Units
T _{SD}	Thermal Shutdown Threshold ¹			157		°C
T _{HYST}	Threshold Hysteresis ¹			15	30	°C

Notes:

1. Guaranteed by design.
2. Soft start charge current equation: $I_{ss_chg} = 1.2V/R_{FREQ}$.
3. Switching frequency equation: $Freq = 1/[(90 \text{ pF} \times R_{FREQ}) + 150 \text{ ns}]$, where Freq is (Hz).
4. Low power mode clamp equation: $V_{CLAMP} = 0.3 * (R_{RCLP}/R_{FREQ})$.
5. Minimum and maximum current are guaranteed by design.

3. Pin Configuration

The following illustration shows the device pin diagram from the top views.

Figure 3-1. Pin Diagram

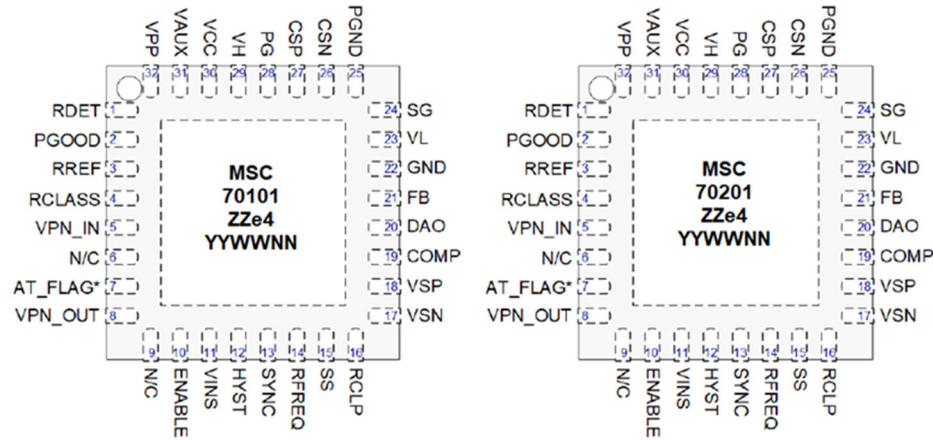

ZZ = Random character with no meaning and e4 = 2nd level interconnect.

YY = Year, WW = Week, NNN = Trace Code

The following table lists the pin descriptions of the PD70101/PD70201 device.

Table 3-1. Pin Descriptions

Pin Number	PD70101 Pin Name	PD70201 Pin Name	Description
1	RDET	RDET	Valid Detection Resistor: Connect a 24.9 kΩ, 1% resistor from this pin to VPP.
2	PGOOD	PGOOD	Open Drain Output (active low): This flag is generated to indicate the power rails (VPN_OUT) are ready.
3	RREF	RREF	Bias current resistor for the PD Interface. Connect a 240k 1% resistor between this pin and VPN_IN.
4	RCLASS	RCLASS	Power Classification Setting: Connect external class resistor between this pin and VPN_IN.
5	VPN_IN	VPN_IN	VPort Negative Input: Connected to the isolating switch input N-channel MOSFET source.
6	N/C	N/C	Not used.
7	N/C	AT_FLAG	Open Drain Output (active low): This flag indicates if the chip detects an IEEE 802.3at compliant PSE.
8	VPN_OUT	VPN_OUT	VPort Negative Output: Connected to the isolating switch output. N-channel MOSFET Drain.
9	N/C	N/C	Not Used.
10	ENABLE	ENABLE	Logic level Enable input for DC-DC controller. Pulling this pin to VL turns on the DC-DC controller. This allows the DC-DC controller to be turned on without power to the PD interface.

PD70101 and PD70201

Pin Configuration

.....continued			
Pin Number	PD70101 Pin Name	PD70201 Pin Name	Description
11	VINS	VINS	VPP input voltage sensing for UVLO comparator. Connect to an external resistor divider from VPP to GND. Threshold is 1.2 V reference.
12	HYST	HYST	Output of the VINS/UVLO comparator. This pin is used for VPP UVLO hysteresis programming.
13	SYNC	SYNC	External Clock synchronization for the DC-DC controller. Connect an external clock as defined in the EC table to this pin to synchronize the DC-DC converter switching frequency to this clock. PG rising edge is synchronized with the clock rising edge.
14	RFREQ	RFREQ	DC-DC Switching Frequency Setting. Connect a resistor from this pin to GND to set the switching frequency.
15	SS	SS	Soft-start: Connect a capacitor from this pin to GND to set the soft-start time of the DC-DC converter. This capacitor is charged with an internal current source to 1.2 V.
16	RCLP	RCLP	Low Power Mode Clamp. Connect a resistor from this pin to GND to program the LPM clamping voltage or connect this pin to GND to disable LPM.
17	VSN	VSN	Differential Amplifier's negative input. Connect this to the junction of a resistor divider from Vo- to GND for the Direct Buck converter application.
18	VSP	VSP	Differential Amplifier's positive input. Connect this to the junction of a resistor divider from Vo+ to GND for the Direct Buck converter application.
19	COMP	COMP	Error Amplifier Output. Short to FB pin when driven directly with an optoisolator for Isolated DC-DC Converter. Connect to FB via RC compensation networks for Non-Isolated Direct Buck Converter.
20	DAO	DAO	Differential Amplifier Output. Connect to FB (externally) for Non-Isolated Direct Buck Converter.
21	FB	FB	Inverting Input of the Error Amplifier. Connect to opto-coupler for Isolated DC-DC. Connect to RC compensation networks for Non-isolated DC-DC.
22	GND	GND	This is Analog GND. Connect to a local AGND plane. Soft-start capacitor and the frequency setting resistor return to this local GND plane.
23	VL	VL	5 V (GND reference) internal LDO Output. Connect a 1 μ F or higher ceramic cap from VL to GND.
24	SG	SG	Secondary Gate Driver. Output is the compliment of PG output. Leave open (NC) if not used. SG is low when in Low Power Skip Mode.
25	PGND	PGND	This is the Power Ground. Connect to a local PGND plane. Input, VCC decoupling capacitors, PG and SG drivers. Primary current sense resistor return to this PGND.

PD70101 and PD70201

Pin Configuration

.....continued			
Pin Number	PD70101 Pin Name	PD70201 Pin Name	Description
26	CSN	CSN	Negative Input of the Current Sense Amplifier. Kelvin connect to the PGND side of the primary current sense resistor.
27	CSP	CSP	Positive Input of the Current Sense Amplifier. Kelvin connect to the Non-PGND side of the primary current sense resistor.
28	PG	PG	Primary Gate Driver. Connect to the gate of the primary side Power MOSFET, directly or via a resistor.
29	VH	VH	5V High side (VCC reference) internal LDO Output. Connect a 0.1 μ F or higher ceramic cap from VH to VCC.
30	VCC	VCC	Input Supply to the DC-DC Controller. Connect a 4.7 μ F or higher ceramic capacitor from this pin to PGND. Alternately, a parallel combination of 1 μ F ceramic and greater than 10 μ F electrolytic capacitor can be used.
31	VAUX	VAUX	Auxiliary voltage reference to VPN_OUT; this voltage can be used for DC-DC start up when operated with a bootstrapped voltage source. For applications with POE power only connect directly to VCC; for applications using multiple power sources (such as a wall adapter), connect to VCC pin through a small, low current, 30 V rated schottky diode.
32	VPP	VPP	This is the positive terminal of the POE input port. Connect to the positive terminal of the input bridges at the CDET positive side.
EP	Exposed Pad	Exposed Pad	Thermal Pad; electrically connected to VPN_IN. For proper thermal management should be tied to a large copper fill or plane that is electrically connected to VPN_IN.

4. Package Specifications

The following section describes the package information of the PD70101/PD70201 device.

Figure 4-1. Package Outline Diagram

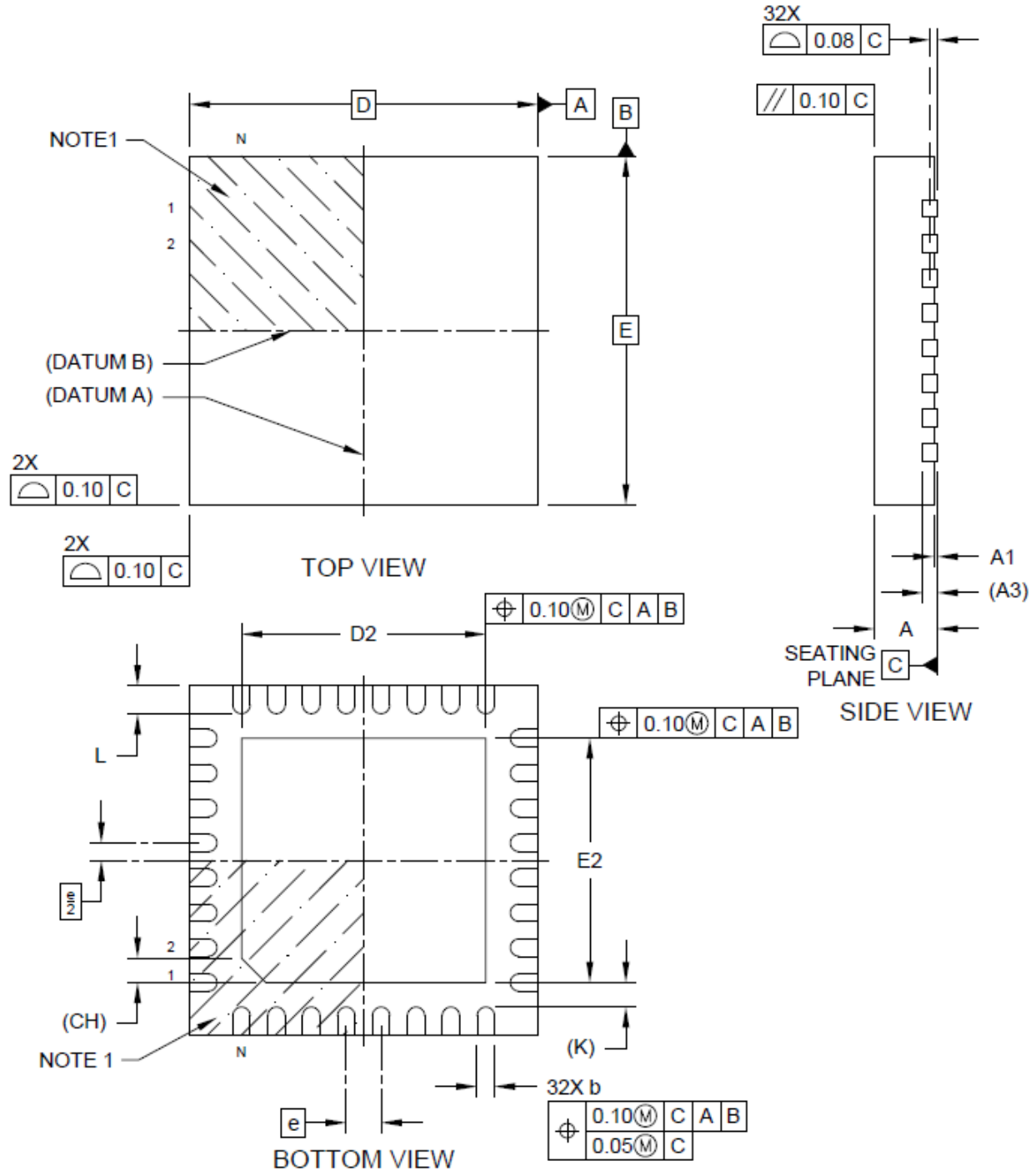

Dimensions do not include protrusions; these shall not exceed 0.155 mm (0.006") on any side; lead dimension shall not include solder coverage. Dimensions are in millimeters. Inches are for reference only.

The following table lists the dimensions for the PD70101/PD70201 package.

PD70101 and PD70201

Package Specifications

Table 4-1. Package Dimensions

Units		Millimeters		
Dimension Limist		Min	Nom	Max
Number of terminals	N	—	32	—
Pitch	e	0.50 BSC		
Overall height	A	0.80	0.90	1.00
Standoff	A1	0.00	0.02	0.05
Terminal thickness	A3	0.20 REF		
Overall length	D	5.00 BSC		
Exposed pad length	D2	3.40	3.50	3.60
Overall width	E	5.00 BSC		
Exposed pad width	E2	3.40	3.50	3.60
Terminal width	b	0.20	0.25	0.30
Terminal length	L	0.30	0.40	0.50
Terminal-to-exposedp-ad	K	0.35 REF		
Index corner chamfer	CH	0.35 REF		

Notes:

1. Pin 1 visual index feature may vary, but must be located within the hatched area.
2. Package is saw singulated.
3. Dimensioning and tolerancing per ASME Y14.5M.
 - a. BSC: Basic Dimension. Theoretically exact value shown without tolerances.
 - b. REF: Reference Dimension, usually without tolerance, for information purposes only.
4. For the most current package drawings, please see the Microchip Packaging Specification located at www.microchip.com/packaging.

5. Recommended PCB Layout

The following figures show the PD70101/201 recommended PCB layout for 32-pin QFN 5 mm × 5 mm.

Figure 5-1. Solder Mask

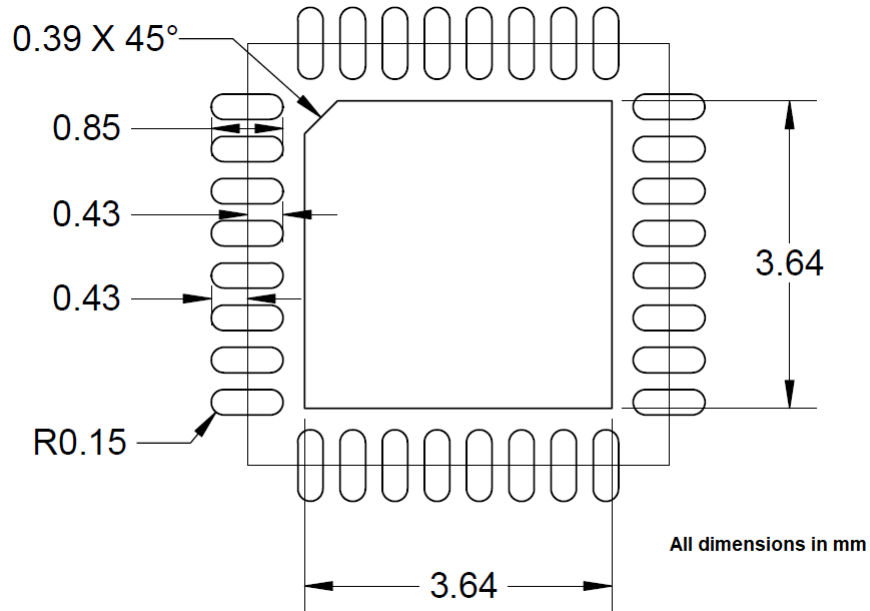

Figure 5-2. Top Layer Copper

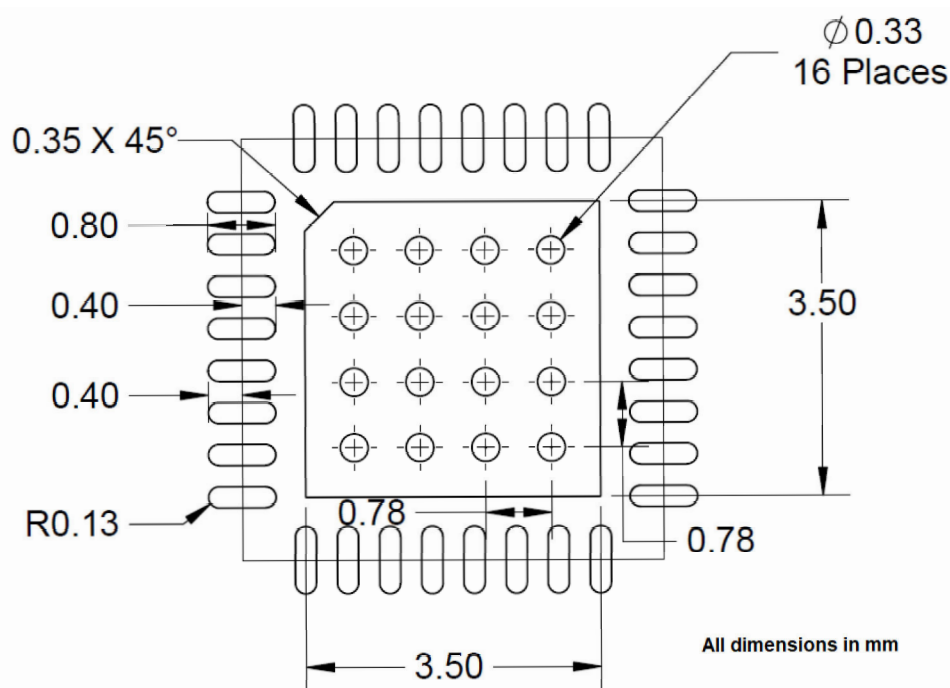
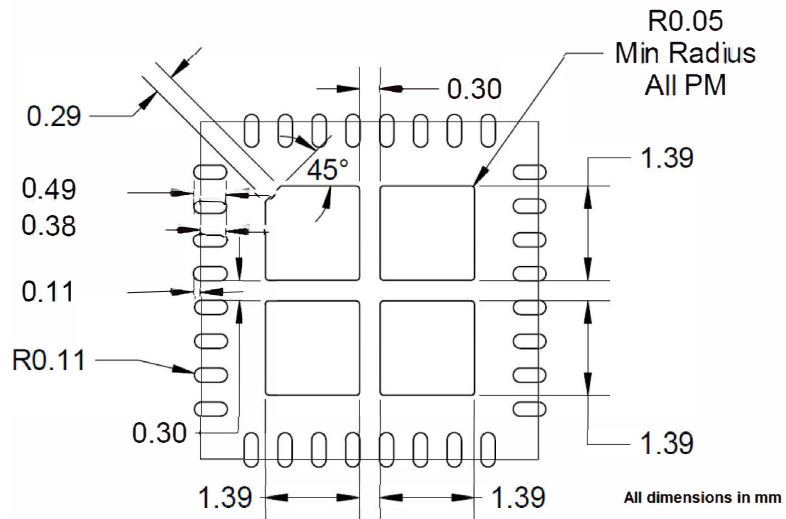
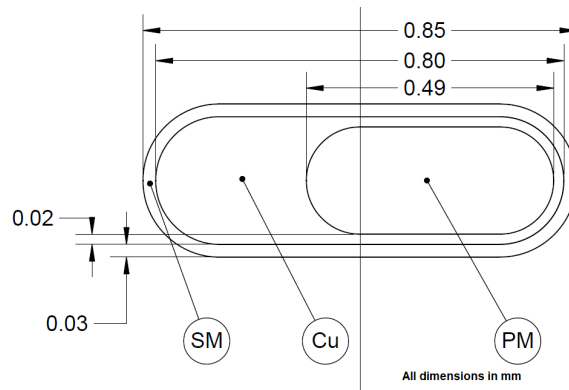

Figure 5-3. Paste Mask



Note: Paste mask stencil is 5 mm thick. All paste mask openings have a radius of 0.05 mm.

Figure 5-4. Pin Geometry



6. Theory of Operation

The PD70101/PD70201 device theory of operation is described in the following sections.

The PD70101/PD70201 IC integrates IEEE 802.3af/at compliant PD front-end functions including Detection, Physical Layer Classification, Two-events Classification (PD70201 only), Power Good, Soft Start Current Limiting, Over-Current Protection, and Bulk Capacitor Discharge with a PWM controller. The integrated PWM controller function provides a PWM controller solution with a minimum requirement of external components.

6.1 Detection

IEEE 802.3af/at-compliant detection is provided by means of a 24.9 K Ω resistor connected between VPP and RDET pin. RDET pin is connected to VPN_IN via an open drain MOSFET with a maximum specified R_{DS(on)} of 50 Ω . Internal logic monitors VPP to VPN_IN and connects the RDET pin to VPN_IN when the rising VPP to VPN_IN voltage is between 1.1 V and 10.1 V. When rising VPP to VPN_IN voltages exceed 10.1 V, the MOSFET is switched off. Once above 10.1 V, falling VPP to VPN_IN voltage between 2.45 V and 4.85 V will reconnect RDET pin to VPN_IN.

6.2 Physical Layer Classification

Physical Layer (hardware) Classification per IEEE 802.3af/at is generated via a regulated reference voltage of 1.2 V, switched onto the RCLASS pin. Internal logic monitors the VPP to VPN_IN voltage and connects the 1.2 V reference to RCLASS pin at a rising VPP to VPN_IN voltage threshold between 11.4 V and 13.7 V. Once VPP to VPN_IN has exceeded the rising threshold, there is a 1 V typical hysteresis between the VPP rising (turn-on) threshold and the VPP falling (turn-off) threshold.

The 1.2 V reference stays connected to the RCLASS pin until the VPP to VPN_IN rising voltage exceeds the upper turn-off threshold of 20.9 V to 23.9 V. The 1.2 V reference voltage is disconnected from the RCLASS pin at VPP to VPN_IN voltages above the upper threshold.

Classification current signature is provided via a resistor connected between RCLASS pin and VPN_IN. The classification current is therefore the current drawn by the PD70101/PD70201 IC during the classification phase, and is simply the 1.2 V reference voltage divided by the RCLASS resistor value. The maximum current available at the RCLASS pin is current limited to 68 mA (typical).

6.3 Two-Events Detection and AT Flag

The PD70201 IC provides IEEE 802.3at Type 2 compliant detection of the two-events classification signature, and generation of the AT flag. This feature is available on the PD70201 IC only.

The two-events classification signature is a means by which an IEEE 802.3at Type 2 Power Source can inform a compliant PD that it is AT Type 2 compliant, and as such is capable of providing AT Type 2 power levels.

The Power Source communicates the Type 2-compliant signature by toggling the VPP to VPN_IN voltage twice (2 events) during the Physical Layer Classification phase. The VPP to VPN_IN voltage is toggled from the Physical Layer Classification's voltage level (13.5 V to 20.9 V) down to a voltage Mark level. Voltage Mark level is specified as a VPP to VPN_IN voltage of 4.9 V to 10.1 V.

PD70201 IC recognizes a VPP to VPN_IN falling edge from Classification level to Mark level as being one event of the Two-Events Signature. If two such falling edges are detected, PD70201 will assert with 80 ms delay AT flag by means of an open drain MOSFET connected between AT_FLAG pin and VPN_OUT.

AT_FLAG pin is active low; a low impedance state between AT_FLAG and VPN_OUT indicates a valid Two-Events Classification Signature was received, and the Power Source is AT Type 2 compliant.

AT_FLAG MOSFET is capable of 5 mA of current and can be pulled up to VPP.

6.4 Soft Start and Inrush Current Protection

PD70101/PD70201 IC contains an internal isolation switch that provides ground isolation between power source and PD application during Detection and Classification phases. The isolation switch is a N- channel MOSFET, wired in a common source configuration where the MOSFET's Source is connected to Power Source ground at VPN_IN, and the MOSFET's Drain is connected to application's primary ground at VPN_OUT.

Internal logic monitors VPP to VPN_IN voltage and keeps the MOSFET in a high impedance state until VPP to VPN_IN voltage reaches turn-on threshold of 36 V to 42 V. Once VPP to VPN_IN voltage exceeds this threshold, the MOSFET is switched into one of two modes.

Mode into which the MOSFET is switched is determined by the voltage developed across the MOSFET, or put another way, the VPN_OUT to VPN_IN differential voltage. Two modes are defined as in the following table.

Table 6-1. Isolation Switch Modes

VPN_OUT to VPN_IN	Mode	Description
≥ 0.7 V	Soft start	Limits VPN_OUT current to 240 mA (typical)
≤ 0.7 V	Normal operating	Limits VPN_OUT current to 1.8 A (typical)

By controlling the MOSFET current based on VPN_OUT to VPN_IN voltage, inrush currents generated by fully discharged bulk capacitors can be limited. This method limits current to a maximum of 350 mA, compliant with IEEE 802.3af/at specification.

Soft Start current limiting is required to reduce occurrences of voltage sag at the PD input during device power-up. A comparison is shown in [figure 3 \(see page 7\)](#).

Figure 6-1. Comparison of Input Voltages without Soft-start (Hard Startup) and Soft-start (Soft Startup)

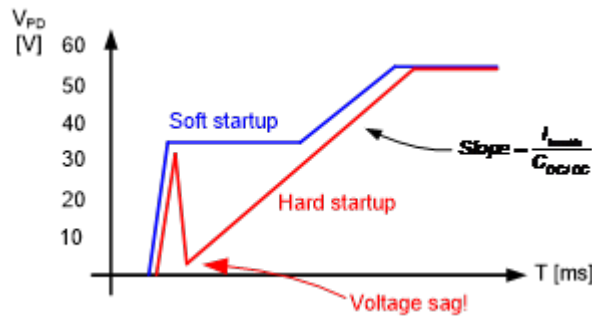

Once bulk capacitance has charged up to a point where VPN_OUT to VPN_IN differential voltage is less than 0.7 V, the isolation MOSFET is switched into normal operating mode with MOSFET current limit set at 1.8 A (typical), to provide over-current protection.

PD70101 and PD70201 ICs are different in their respective isolation MOSFET's continuous current handling capability. The maximum isolation MOSFET's continuous current handling capability is 450 mA for PD70101 and 1123 mA for PD70201.

An adequate heat sink for the PD70101/PD70201 IC's exposed pad must be provided to achieve these current levels without damaging the IC. A large, heavy copper fill area and/or a heavy ground plane with Thermal vias are recommended.

Internal logic monitoring VPP to VPN_IN will place the isolation switch MOSFET in a high impedance state if voltage between VPP and VPN_IN drops below 31 V to 34 V.

6.5 Over-Current Protection

An over-current protection is provided on the PD70101/PD70201 IC using the Isolation Switch MOSFET, which limits the VPN_OUT current to 1.8 A during normal operation. See previous description of Soft Start.

6.6 Power Good

During Soft Start mode, the PD70101/PD70201 IC monitors VPN_OUT to VPN_IN differential voltage. When this voltage is less than 0.7 V (maximum), the IC enters normal operation mode and the isolation switch current limit is increased to 1.8 A (typical). At this same 0.7 V (maximum) threshold the Power Good signal is asserted by means of an open drain MOSFET between PGOOD and VPN_OUT.

PGOOD pin is active low; a low impedance state between PGOOD and VPN_OUT indicates the Soft Start mode has finished and the isolation switch has transitioned into normal operating mode.

PGOOD MOSFET can handle current of 5 mA and can be pulled up to VPP.

The application load should begin after no less than 80 ms after PGOOD is activated according to IEEE 802.3.

6.7 Start-Up Supply

PD70101/PD70201 IC provides a 10.5 V (typical) regulated output used as a start-up supply for the integrated DC/DC controller when VCC is provided via a bootstrap winding. This regulated supply is available at VAUX pin, and is referenced to VPN_OUT pin. The VAUX start-up supply is current-limited at 10 mA (minimum).

For stability, the start-up regulator requires a minimum of 4.7 μ F ceramic capacitor connected directly between VAUX and PGND pins (most applications will connect PGND to VPN_OUT).

For applications where power to the DC-DC controller is provided by POE only, the VAUX pin is connected directly to VCC. For applications which have alternate power sources (such as a wall adaptor), the VAUX pin output is connected to the VCC pin through a series diode. This diode is typically a low current diode with a 30 V rating.

6.8 PD Interface Thermal Protection

Both PD70101 and PD70201 IC contain temperature sensors which individually monitor both the isolation MOSFET and the classification current source for over temperature conditions. In case of an over temperature condition, the sensor will activate protection circuitry which will disconnect its respective monitored function.

6.9 Bulk Capacitor Discharge

The bulk capacitor discharge circuitry eliminates the need to place a diode in series with the VPP line to prevent an application's bulk capacitance from discharging through the detection resistor and the isolation switch MOSFET's body diode. Discharge current through the detection resistor can cause failure of the detection signature in cases where a PD is connected and the bulk capacitance is not fully discharged.

During normal operation, PD70101/PD70201 IC continuously monitors voltage at VPP to VPN_IN. Should VPP to VPN_IN voltage fall below isolation switch turn-off threshold (31 V to 34 V), isolation switch MOSFET is immediately placed in a high-impedance state. At this point the internal logic monitors the voltage at VPP to VPN_OUT.

If VPP to VPN_OUT voltage is between 1.5 V to 32 V, minimum 23 mA constant current source is connected across the VPP and VPN_OUT pins. This constant current source provides bulk capacitor discharge.

A 220 μ F bulk capacitance can be discharged from 32 V to 1.5 V in a maximum period of 292 ms.

6.10 DC-DC Start-Up

The DC-DC controller starts up when it receives the PGOOD high signal from the front-end, or ENABLE goes high provided that VCC UVLO have passed. When the PGOOD signal or ENABLE goes high, the start-up sequence begins with ramping up the SS pin from GND to 1.2 V. For isolated applications the output voltage may reach the maximum level before the SS reaches 1.2 V, depending on the output loading condition. In applications with lighter loads, the output reaches regulation level sooner than in heavy loads, as in this mode the SS voltage directly controls the peak inductor current; hence the energy is delivered to the load. The external secondary error amplifier regulates the output voltage and controls the peak inductor current via the opto-coupler across the isolation barrier.

For non-isolated applications, because the internal error amplifier is used to close the regulation loop, the output reaches the regulation level when SS reaches 1.2 V.

An additional internal offset is added to the FB to ensure that COMP does not reach its upper limit because of amplifier input offset. This offset is removed (slowly to avoid overshoot) when the SS ramp is complete.

Low Power mode is not supported during SS ramp as it is not necessary.

6.11 Current Limit and Short Circuit Protection

The DC-DC converter is a peak current mode controller; an internal current sense amplifier with a gain of 5 monitors the voltage across an external current sense resistor and regulates the output based on the current through the resistor. If the output of the internal current sense amplifier reaches 1.2 V, the converter will truncate the PWM output, and thus limit the output current.

If the output of the internal current sense amplifier reaches 1.8 V, the controller enters hiccup mode by discharging the SS capacitor with a constant current that equals 10% of the charging current during ramp up.

This discharge continues until $V_{SS} = 50$ mV where an internal ~ 50 Ω MOSFET connected to SS turns on for 25 clock cycles to ensure the SS capacitor fully discharges to GND before ramping back up and restart. The converter will exit the hiccup mode when the over current condition is removed.

6.12 Low Power Mode Operation

The devices offer a pulse skipping operation for light load condition, referred to as Low Power Mode (LPM), to improve the efficiency of light load operation by reducing the power dissipation especially in high frequency switching. Using an external resistor from RCLP pin to GND, the user can program the output power when the unit enters pulse skipping.

Pulse skipping mode is disabled until SS ramp is completed, regardless of the LPM status.

6.13 Input (VPP and VCC) Under Voltage Lock Out

The PD interface circuit offers an internal PGOOD signal that can be used to start the DC-DC converter; however, the threshold of the PGOOD is fixed at $VPN_OUT - VPIN_IN \leq 0.7$ V. This may not fit all possible applications. Therefore, the device offers an option to have a programmable UVLO which is tied to level of $VPP - VPIN_OUT$, plus a programmable hysteresis. The voltage developed across a simple resistor divider is sensed at VINS, and will enable/disable the PWM controller at a nominal 1.2 V threshold. A third resistor connected between VINS and HYST pins allows programmable hysteresis. This feature enables the end user to tailor to any desired systems application's requirement for turn on and turn off time. In addition to the VPP sensing for UVLO, the devices also have VCC UVLO to ensure that the PWM controller is always properly powered during operation. These features provide robust solutions under various systems disturbances.

6.14 External Enable

The PD interface circuit provides an internal PGOOD signal that is used to enable the DC-DC converter when powered by the PoE input; however, for applications that require input power from a wall adaptor, the internal PGOOD signal is not functional. For these applications an external enable input is provided, allowing a non-PoE power source (such as a wall adaptor) the ability to start the DC-DC converter. The Enable pin is active high, and is driven by a 5 V maximum signal referenced to GND. When the DC-DC converter is powered by the PD interface (PoE power), the Enable pin will not disable the controller. It may be tied to ground or left floating when not used.

7. Ordering Information

The following table lists the ordering information of the PD70101/PD70201 device.

Table 7-1. Ordering Information

Ambient Temperature	Type	Package	Part Number	Packaging Type
-40 °C to 85 °C	RoHS compliant, Pb-free	QFN 5x5 Plastic 32-pin	PD70101ILQ (IEEE 802.3af)	Bulk/Tube
			PD70101ILQ-TR (IEEE 802.3af)	Tape and Reel
			PD70201ILQ (IEEE 802.3at)	Bulk/Tube
			PD70201ILQ-TR (IEEE 802.3at)	Tape and Reel

8. Reference Documents

The following is a list of documents you can refer to for more information.

- [AN3551: PD70101 and PD70201 PD Device Layout Guidelines](#)
- [AN3472: Implementing Auxiliary Power in PoE](#)
- [AN3471: Designing a Type 1/2 802.3 or HDBaseT Type 3 Powered Device Using PD702x1 and PD701x1 ICs](#)

9. Revision History

Revision	Date	Description
B	October 2021	The following is the summary of changes in this revision. <ul style="list-style-type: none"> Updated the figure and table in the 4. Package Specifications section. Updated the 5. Recommended PCB Layout section.
A	December 2020	The following is the summary of changes in this revision. <ul style="list-style-type: none"> Migrated this data sheet to the Microchip template. Updated the PD-000391083 to DS-00003738A. Added the Recommended PCB Layout diagrams.
3.0	October 2019	The following is the summary of changes in this revision. <ul style="list-style-type: none"> Microsemi logo was added to the pin out figures. Made formatting changes to application figures. Divided Electrical Characteristics table under ten different titles.
2.0	January 2017	The following is the summary of changes. <ul style="list-style-type: none"> Changed MSL from 1 to 3. Updated formatting and disclaimer.
1.9	November 2015	In this revision, the maximum value for VSW-START was added.
1.8	May 2015	The following is the summary of changes in this revision. <ul style="list-style-type: none"> Updated differential amplifier and GND connection in figures 2 and 3. Added the differential amplifier input (VSN, VSP) to Absolute Maximum Ratings table.
1.7	November 2014	The following is the summary of changes in this revision. <ul style="list-style-type: none"> Updated information continuous operation load current parameter. Updated Pin 3 description.
1.6	March 2014	Updated differential amplifier gain in figure 2.
1.5	February 2014	In this revision, minor formatting corrections were made.
1.4	February 2014	There were general updates in this revision.
1.3	November 2013	The following are the changes in this revision. <ul style="list-style-type: none"> Updated Vcc disable. Added note 5 and removed A from 70101A in the package pin out details.
1.2	June 2012	In this revision, Switching Frequency Accuracy specification limits and the equation in note 3 were updated.
1.1	February 2012	In this revision, the document's format and address were updated.
1.0	September 2011	Initial Revision.

The Microchip Website

Microchip provides online support via our website at www.microchip.com/. This website is used to make files and information easily available to customers. Some of the content available includes:

- **Product Support** – Data sheets and errata, application notes and sample programs, design resources, user's guides and hardware support documents, latest software releases and archived software
- **General Technical Support** – Frequently Asked Questions (FAQs), technical support requests, online discussion groups, Microchip design partner program member listing
- **Business of Microchip** – Product selector and ordering guides, latest Microchip press releases, listing of seminars and events, listings of Microchip sales offices, distributors and factory representatives

Product Change Notification Service

Microchip's product change notification service helps keep customers current on Microchip products. Subscribers will receive email notification whenever there are changes, updates, revisions or errata related to a specified product family or development tool of interest.

To register, go to www.microchip.com/pcn and follow the registration instructions.

Customer Support

Users of Microchip products can receive assistance through several channels:

- Distributor or Representative
- Local Sales Office
- Embedded Solutions Engineer (ESE)
- Technical Support

Customers should contact their distributor, representative or ESE for support. Local sales offices are also available to help customers. A listing of sales offices and locations is included in this document.

Technical support is available through the website at: www.microchip.com/support

Microchip Devices Code Protection Feature

Note the following details of the code protection feature on Microchip products:

- Microchip products meet the specifications contained in their particular Microchip Data Sheet.
- Microchip believes that its family of products is secure when used in the intended manner, within operating specifications, and under normal conditions.
- Microchip values and aggressively protects its intellectual property rights. Attempts to breach the code protection features of Microchip product is strictly prohibited and may violate the Digital Millennium Copyright Act.
- Neither Microchip nor any other semiconductor manufacturer can guarantee the security of its code. Code protection does not mean that we are guaranteeing the product is "unbreakable". Code protection is constantly evolving. Microchip is committed to continuously improving the code protection features of our products.

Legal Notice

This publication and the information herein may be used only with Microchip products, including to design, test, and integrate Microchip products with your application. Use of this information in any other manner violates these terms. Information regarding device applications is provided only for your convenience and may be superseded by updates. It is your responsibility to ensure that your application meets with your specifications. Contact your local Microchip sales office for additional support or, obtain additional support at www.microchip.com/en-us/support/design-help/client-support-services.

THIS INFORMATION IS PROVIDED BY MICROCHIP "AS IS". MICROCHIP MAKES NO REPRESENTATIONS OR WARRANTIES OF ANY KIND WHETHER EXPRESS OR IMPLIED, WRITTEN OR ORAL, STATUTORY OR OTHERWISE, RELATED TO THE INFORMATION INCLUDING BUT NOT LIMITED TO ANY IMPLIED WARRANTIES OF NON-INFRINGEMENT, MERCHANTABILITY, AND FITNESS FOR A PARTICULAR PURPOSE, OR WARRANTIES RELATED TO ITS CONDITION, QUALITY, OR PERFORMANCE.

IN NO EVENT WILL MICROCHIP BE LIABLE FOR ANY INDIRECT, SPECIAL, PUNITIVE, INCIDENTAL, OR CONSEQUENTIAL LOSS, DAMAGE, COST, OR EXPENSE OF ANY KIND WHATSOEVER RELATED TO THE INFORMATION OR ITS USE, HOWEVER CAUSED, EVEN IF MICROCHIP HAS BEEN ADVISED OF THE POSSIBILITY OR THE DAMAGES ARE FORESEEABLE. TO THE FULLEST EXTENT ALLOWED BY LAW, MICROCHIP'S TOTAL LIABILITY ON ALL CLAIMS IN ANY WAY RELATED TO THE INFORMATION OR ITS USE WILL NOT EXCEED THE AMOUNT OF FEES, IF ANY, THAT YOU HAVE PAID DIRECTLY TO MICROCHIP FOR THE INFORMATION.

Use of Microchip devices in life support and/or safety applications is entirely at the buyer's risk, and the buyer agrees to defend, indemnify and hold harmless Microchip from any and all damages, claims, suits, or expenses resulting from such use. No licenses are conveyed, implicitly or otherwise, under any Microchip intellectual property rights unless otherwise stated.

Trademarks

The Microchip name and logo, the Microchip logo, Adaptec, AnyRate, AVR, AVR logo, AVR Freaks, BesTime, BitCloud, chipKIT, chipKIT logo, CryptoMemory, CryptoRF, dsPIC, FlashFlex, flexPWR, HELDO, IGLOO, JukeBlox, KeeLoq, Kleer, LANCheck, LinkMD, maXStylus, maXTouch, MediaLB, megaAVR, Microsemi, Microsemi logo, MOST, MOST logo, MPLAB, OptoLyzer, PackeTime, PIC, picoPower, PICSTART, PIC32 logo, PolarFire, Prochip Designer, QTouch, SAM-BA, SenGenuity, SpyNIC, SST, SST Logo, SuperFlash, Symmetricom, SyncServer, Tachyon, TimeSource, tinyAVR, UNI/O, Vectron, and XMEGA are registered trademarks of Microchip Technology Incorporated in the U.S.A. and other countries.

AgileSwitch, APT, ClockWorks, The Embedded Control Solutions Company, EtherSynch, FlashTec, Hyper Speed Control, HyperLight Load, IntelliMOS, Libero, motorBench, mTouch, Powermite 3, Precision Edge, ProASIC, ProASIC Plus, ProASIC Plus logo, Quiet-Wire, SmartFusion, SyncWorld, Temux, TimeCesium, TimeHub, TimePictra, TimeProvider, WinPath, and ZL are registered trademarks of Microchip Technology Incorporated in the U.S.A.

Adjacent Key Suppression, AKS, Analog-for-the-Digital Age, Any Capacitor, AnyIn, AnyOut, Augmented Switching, BlueSky, BodyCom, CodeGuard, CryptoAuthentication, CryptoAutomotive, CryptoCompanion, CryptoController, dsPICDEM, dsPICDEM.net, Dynamic Average Matching, DAM, ECAN, Espresso T1S, EtherGREEN, IdealBridge, In-Circuit Serial Programming, ICSP, INICnet, Intelligent Paralleling, Inter-Chip Connectivity, JitterBlocker, maxCrypto, maxView, memBrain, Mindi, MiWi, MPASM, MPF, MPLAB Certified logo, MPLIB, MPLINK, MultiTRAK, NetDetach, Omniscient Code Generation, PICDEM, PICDEM.net, PICkit, PICtail, PowerSmart, PureSilicon, QMatrix, REAL ICE, Ripple Blocker, RTAX, RTG4, SAM-ICE, Serial Quad I/O, simpleMAP, SimpliPHY, SmartBuffer, SMART-I.S., storClad, SQI, SuperSwitcher, SuperSwitcher II, Switchtec, SynchroPHY, Total Endurance, TSHARC, USBCheck, VariSense, VectorBlox, VeriPHY, ViewSpan, WiperLock, XpressConnect, and ZENA are trademarks of Microchip Technology Incorporated in the U.S.A. and other countries.

SQTP is a service mark of Microchip Technology Incorporated in the U.S.A.

The Adaptec logo, Frequency on Demand, Silicon Storage Technology, and Symmcom are registered trademarks of Microchip Technology Inc. in other countries.

GestIC is a registered trademark of Microchip Technology Germany II GmbH & Co. KG, a subsidiary of Microchip Technology Inc., in other countries.

All other trademarks mentioned herein are property of their respective companies.

© 2021, Microchip Technology Incorporated, Printed in the U.S.A., All Rights Reserved.

ISBN: 978-1-5224-9194-1

Quality Management System

For information regarding Microchip's Quality Management Systems, please visit www.microchip.com/quality.

Worldwide Sales and Service

AMERICAS	ASIA/PACIFIC	ASIA/PACIFIC	EUROPE
<p>Corporate Office 2355 West Chandler Blvd. Chandler, AZ 85224-6199 Tel: 480-792-7200 Tel: 480-792-7277 Technical Support: www.microchip.com/support Web Address: www.microchip.com</p> <p>Atlanta Duluth, GA Tel: 678-957-9614 Fax: 678-957-1455</p> <p>Austin, TX Tel: 512-257-3370</p> <p>Boston Westborough, MA Tel: 774-760-0087 Fax: 774-760-0088</p> <p>Chicago Itasca, IL Tel: 630-285-0071 Fax: 630-285-0075</p> <p>Dallas Addison, TX Tel: 972-818-7423 Fax: 972-818-2924</p> <p>Detroit Novi, MI Tel: 248-848-4000</p> <p>Houston, TX Tel: 281-894-5983</p> <p>Indianapolis Noblesville, IN Tel: 317-773-8323 Fax: 317-773-5453 Tel: 317-536-2380</p> <p>Los Angeles Mission Viejo, CA Tel: 949-462-9523 Fax: 949-462-9608 Tel: 951-273-7800</p> <p>Raleigh, NC Tel: 919-844-7510</p> <p>New York, NY Tel: 631-435-6000</p> <p>San Jose, CA Tel: 408-735-9110 Tel: 408-436-4270</p> <p>Canada - Toronto Tel: 905-695-1980 Fax: 905-695-2078</p>	<p>Australia - Sydney Tel: 61-2-9868-6733</p> <p>China - Beijing Tel: 86-10-8569-7000</p> <p>China - Chengdu Tel: 86-28-8665-5511</p> <p>China - Chongqing Tel: 86-23-8980-9588</p> <p>China - Dongguan Tel: 86-769-8702-9880</p> <p>China - Guangzhou Tel: 86-20-8755-8029</p> <p>China - Hangzhou Tel: 86-571-8792-8115</p> <p>China - Hong Kong SAR Tel: 852-2943-5100</p> <p>China - Nanjing Tel: 86-25-8473-2460</p> <p>China - Qingdao Tel: 86-532-8502-7355</p> <p>China - Shanghai Tel: 86-21-3326-8000</p> <p>China - Shenyang Tel: 86-24-2334-2829</p> <p>China - Shenzhen Tel: 86-755-8864-2200</p> <p>China - Suzhou Tel: 86-186-6233-1526</p> <p>China - Wuhan Tel: 86-27-5980-5300</p> <p>China - Xian Tel: 86-29-8833-7252</p> <p>China - Xiamen Tel: 86-592-2388138</p> <p>China - Zhuhai Tel: 86-756-3210040</p>	<p>India - Bangalore Tel: 91-80-3090-4444</p> <p>India - New Delhi Tel: 91-11-4160-8631</p> <p>India - Pune Tel: 91-20-4121-0141</p> <p>Japan - Osaka Tel: 81-6-6152-7160</p> <p>Japan - Tokyo Tel: 81-3-6880-3770</p> <p>Korea - Daegu Tel: 82-53-744-4301</p> <p>Korea - Seoul Tel: 82-2-554-7200</p> <p>Malaysia - Kuala Lumpur Tel: 60-3-7651-7906</p> <p>Malaysia - Penang Tel: 60-4-227-8870</p> <p>Philippines - Manila Tel: 63-2-634-9065</p> <p>Singapore Tel: 65-6334-8870</p> <p>Taiwan - Hsin Chu Tel: 886-3-577-8366</p> <p>Taiwan - Kaohsiung Tel: 886-7-213-7830</p> <p>Taiwan - Taipei Tel: 886-2-2508-8600</p> <p>Thailand - Bangkok Tel: 66-2-694-1351</p> <p>Vietnam - Ho Chi Minh Tel: 84-28-5448-2100</p>	<p>Austria - Wels Tel: 43-7242-2244-39 Fax: 43-7242-2244-393</p> <p>Denmark - Copenhagen Tel: 45-4485-5910 Fax: 45-4485-2829</p> <p>Finland - Espoo Tel: 358-9-4520-820</p> <p>France - Paris Tel: 33-1-69-53-63-20 Fax: 33-1-69-30-90-79</p> <p>Germany - Garching Tel: 49-8931-9700</p> <p>Germany - Haan Tel: 49-2129-3766400</p> <p>Germany - Heilbronn Tel: 49-7131-72400</p> <p>Germany - Karlsruhe Tel: 49-721-625370</p> <p>Germany - Munich Tel: 49-89-627-144-0 Fax: 49-89-627-144-44</p> <p>Germany - Rosenheim Tel: 49-8031-354-560</p> <p>Israel - Ra'anana Tel: 972-9-744-7705</p> <p>Italy - Milan Tel: 39-0331-742611 Fax: 39-0331-466781</p> <p>Italy - Padova Tel: 39-049-7625286</p> <p>Netherlands - Drunen Tel: 31-416-690399 Fax: 31-416-690340</p> <p>Norway - Trondheim Tel: 47-72884388</p> <p>Poland - Warsaw Tel: 48-22-3325737</p> <p>Romania - Bucharest Tel: 40-21-407-87-50</p> <p>Spain - Madrid Tel: 34-91-708-08-90 Fax: 34-91-708-08-91</p> <p>Sweden - Gothenberg Tel: 46-31-704-60-40</p> <p>Sweden - Stockholm Tel: 46-8-5090-4654</p> <p>UK - Wokingham Tel: 44-118-921-5800 Fax: 44-118-921-5820</p>