

## MAX30001G

# Ultra-Low-Power, Single-Channel Integrated Biopotential (ECG and R-to-R) and Bioimpedance (BioZ) AFE

### General Description

The MAX30001G is a complete, biopotential and bioimpedance (BioZ), analog front-end (AFE) solution for wearable applications. It offers high performance for clinical and fitness applications, with ultra-low power for long battery life. The MAX30001G is a single biopotential channel providing electrocardiogram (ECG) waveforms, heart rate and a single bioimpedance channel capable of measuring respiration.

The biopotential and bioimpedance channels have ESD protection, EMI filtering, internal lead biasing, DC leads-off detection, ultra-low-power, leads-on detection during standby mode, and extensive calibration voltages for built-in self-test. Soft power-up sequencing ensures no large transients are injected into the electrodes. Both channels also have high input impedance, low noise, high CMRR, programmable gain, various low-pass and high-pass filter options, and a high resolution analog-to-digital converter. The biopotential channel is DC coupled, can handle large electrode voltage offsets, and has a fast recovery mode to quickly recover from overdrive conditions, such as defibrillation and electro-surgery. The bioimpedance channel includes integrated programmable current drive, works with common electrodes, and has the flexibility for 2 or 4 electrode measurements. The bioimpedance channel also has AC lead off detection.

The MAX30001G is available in a 30-bump wafer-level package (WLP), operating over the 0°C to +70°C commercial temperature range.

### Applications

- Single-Lead Event Monitors for Arrhythmia Detection
- Single-Lead Wireless Patches for In-Patient/Out-Patient Monitoring
- Chest Band Heart Rate Monitors for Fitness Applications
- Bio Authentication and ECG-On-Demand Applications
- Respiration and Hydration Monitors
- Impedance Based Heart Rate Detection

**Ordering Information** appears at end of data sheet.

### Benefits and Features

- Wide BioZ Drive Current Range (55nA to 96µA)  
Allows for a Wide Impedance Measurement Range
- Can be Used in IEC 60601-2-47:2012 Compliant Systems
- Clinical-Grade ECG and BioZ AFE with High Resolution Data Converter
  - 15.9 Bits ENOB with 3.1µV<sub>P-P</sub> (typ) Noise for ECG
  - 17 Bits ENOB with 1.1µV<sub>P-P</sub> Noise for BioZ
- Better Dry Starts Due to Much Improved Real World CMRR and High Input Impedance
  - Fully Differential Input Structure with CMRR > 100dB
- Offers Better Common-Mode to Differential Mode Conversion Due to High Input Impedance
- High Input Impedance > 1GΩ for Extremely Low Common-to-Differential Mode
- Minimum Signal Attenuation at the Input During Dry Start Due to High Electrode Impedance
- High DC Offset Range of ±650mV (1.8V, typ) Allows to Be Used with Wide Variety of Electrodes
- High AC Dynamic Range of 65mV<sub>P-P</sub> for ECG and ±90mV for BioZ Will Help Prevent Saturation in the Presence of Motion/Direct Electrode Hits
- Longer Battery Life Compared to Competing Solutions
  - 85µW at 1.1V Supply Voltage for ECG
  - 158µW at 1.1V Supply Voltage for BioZ
- Leads-On Interrupt Feature Allows to Keep the µC in Deep Sleep Mode Until Valid Lead Condition is Detected
  - Lead-On Detect Current: 0.7µA (typ)
- Built-In Heart Rate Detection with Interrupt Feature Eliminates the Need to Run HR Algorithm on the µController
  - Robust R-R Detection in High Motion Environment at Extremely Low Power
- Configurable Interrupts Allows the µC Wake-Up Only on Every Heart Beat Reducing the Overall System Power
- 32-Word ECG and 8-Word BioZ FIFOs Allows the MCU to Stay Powered Down for 256ms with Full Data Acquisition
- Shutdown Current of 0.6µA (typ)

Functional Diagram

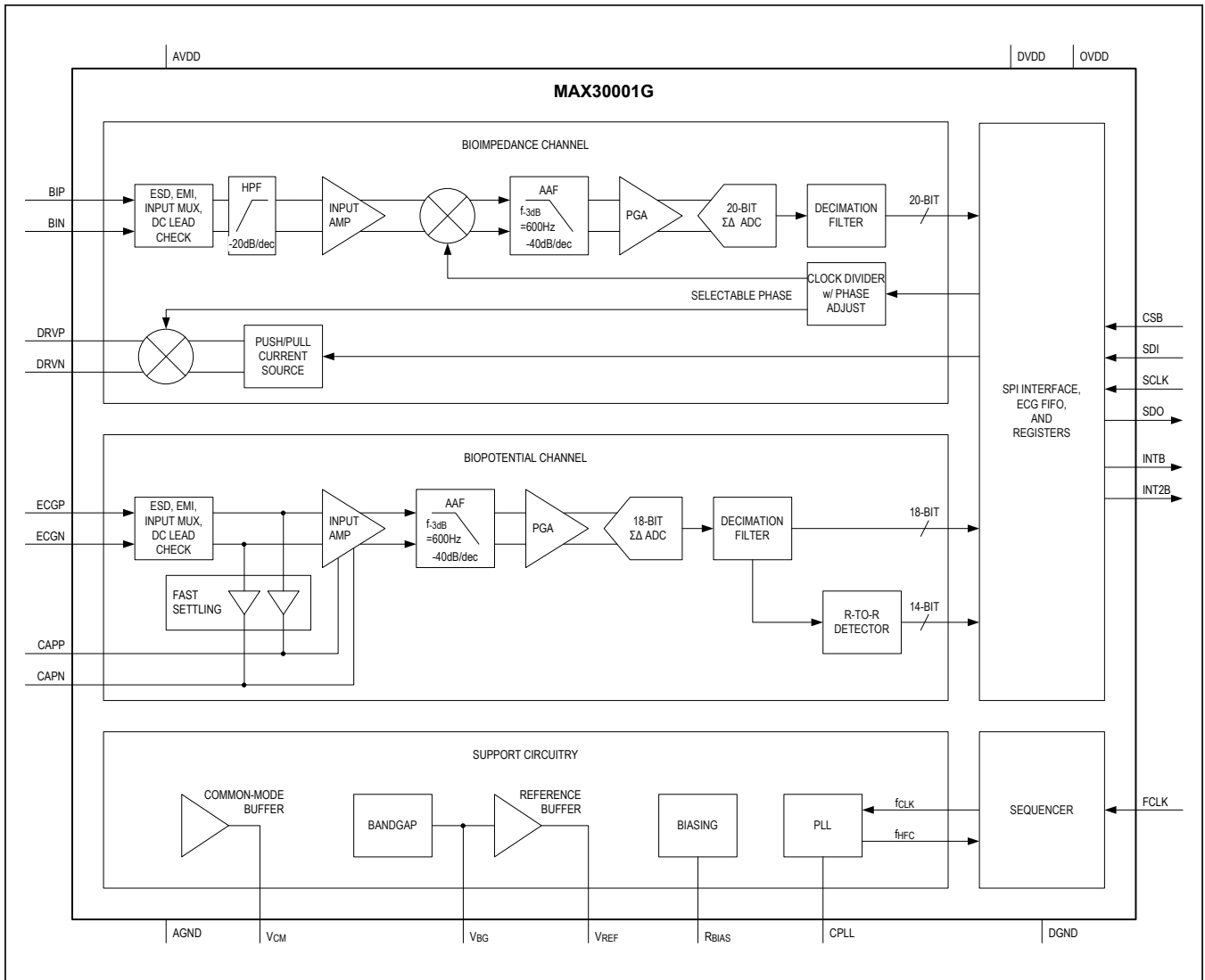

**Absolute Maximum Ratings**

AVDD to AGND .....	-0.3V to +2.0V	Maximum Current into Any Pin.....	±50mA
DVDD to DGND.....	-0.3V to +2.0V	Continuous Power Dissipation (T <sub>A</sub> = +70°C)	
AVDD to DVDD .....	-0.3V to +0.3V	30-Bump WLP	
OVDD to DGND .....	-0.3V to +3.6V	(derate 24.3mW/°C above +70°C).....	1945.5mW
AGND to DGND .....	-0.3V to +0.3V	Operating Temperature Range.....	0°C to +70°C
CSB, SCLK, SDI, FCLK to DGND .....	-0.3V to +3.6V	Junction Temperature.....	+150°C
SDO, INTB, INT2B		Storage Temperature Range.....	-65°C to +150°C
to DGND .....	-0.3V to the lower of (3.6V and OVDD + 0.3V)	Lead Temperature (Soldering, 10sec).....	+300°C
All Other Pins		Soldering Temperature (reflow).....	+260°C
to AGND .....	-0.3V to the lower of (2.0V and AVDD + 0.3V)		

Stresses beyond those listed under "Absolute Maximum Ratings" may cause permanent damage to the device. These are stress ratings only, and functional operation of the device at these or any other conditions beyond those indicated in the operational sections of the specifications is not implied. Exposure to absolute maximum rating conditions for extended periods may affect device reliability.

**Package Information**

<b>PACKAGE TYPE: 30 WLP</b>	
Package Code	W302L2+1
Outline Number	<a href="#">21-100074</a>
Land Pattern Number	Refer to <a href="#">Application Note 1891</a>
<b>THERMAL RESISTANCE, FOUR-LAYER BOARD</b>	
Junction to Ambient (θ <sub>JA</sub> )	41.12°C/W

Package thermal resistances were obtained using the method described in JEDEC specification JESD51-7, using a four-layer board. For detailed information on package thermal considerations, refer to [www.maximintegrated.com/thermal-tutorial](http://www.maximintegrated.com/thermal-tutorial).

For the latest package outline information and land patterns (footprints), go to [www.maximintegrated.com/packages](http://www.maximintegrated.com/packages). Note that a "+", "#", or "-" in the package code indicates RoHS status only. Package drawings may show a different suffix character, but the drawing pertains to the package regardless of RoHS status.

**Electrical Characteristics**

(V<sub>DVDD</sub> = V<sub>AVDD</sub> = +1.1V to +2.0V, V<sub>OVDD</sub> = +1.65V to +3.6V, f<sub>FCLK</sub> = 32.768kHz, LN\_BIOZ = 1, T<sub>A</sub> = T<sub>MIN</sub> to T<sub>MAX</sub>, unless otherwise noted. Typical values are at V<sub>DVDD</sub> = V<sub>AVDD</sub> = +1.8V, V<sub>OVDD</sub> = +2.5V, T<sub>A</sub> = +25°C.) (Note 1)

PARAMETER	SYMBOL	CONDITIONS	MIN	TYP	MAX	UNITS
<b>ECG CHANNEL</b>						
AC Differential Input Range		V <sub>AVDD</sub> = +1.1V, THD < 0.3%	-15		+15	mV <sub>P-P</sub>
		V <sub>AVDD</sub> = +1.8V, THD < 0.3%		±32.5		
DC Differential Input Range		V <sub>AVDD</sub> = +1.1V, shift from nominal gain < 2%	-300		+300	mV
		V <sub>AVDD</sub> = +1.8V		±650		
Common Mode Input Range		V <sub>AVDD</sub> = +1.1V, from V <sub>MID</sub> , shift from nominal gain < 2%	-150		+150	mV
		V <sub>AVDD</sub> = +1.8V, from V <sub>MID</sub> , shift from nominal gain < 2%		±550		
Common Mode Rejection Ratio	CMRR	0Ω source impedance, f = 64Hz, T <sub>A</sub> = +25°C (Note 2)	100	115		dB
		With impedance mismatch (Note 3)		77		

## Electrical Characteristics (continued)

( $V_{DVDD} = V_{AVDD} = +1.1V$  to  $+2.0V$ ,  $V_{OVDD} = +1.65V$  to  $+3.6V$ ,  $f_{CLK} = 32.768kHz$ ,  $LN\_BIOZ = 1$ ,  $T_A = T_{MIN}$  to  $T_{MAX}$ , unless otherwise noted. Typical values are at  $V_{DVDD} = V_{AVDD} = +1.8V$ ,  $V_{OVDD} = +2.5V$ ,  $T_A = +25^{\circ}C$ .) (Note 1)

PARAMETER	SYMBOL	CONDITIONS	MIN	TYP	MAX	UNITS
ECG Channel Input Referred Noise		BW = 0.05 – 150Hz, $G_{CH} = 20x$		0.77		$\mu V_{RMS}$
				4.6		$\mu V_{P-P}$
		BW = 0.05 – 40Hz, $G_{CH} = 20x$ (Note 2)		0.46	1.0	$\mu V_{RMS}$
				3.1	6.6	$\mu V_{P-P}$
Input Leakage Current		$T_A = +25^{\circ}C$	-1	$\pm 0.1$	+1	nA
Input Impedance (INA)		Common-mode, DC		45		$G\Omega$
		Differential, DC		1500		$M\Omega$
ECG Channel Total Harmonic Distortion	THD	$V_{AVDD} = +1.80V$ , $V_{IN} = 65mV_{P-P}$ , $f_{IN} = 64Hz$ , $G_{CH} = 20x$ , electrode offset = $\pm 300mV$		0.025		%
		$V_{AVDD} = +1.1V$ , $V_{IN} = 30mV_{P-P}$ , $f_{IN} = 64Hz$ , $G_{CH} = 20x$ , electrode offset = $\pm 300mV$			0.3	%
ECG Channel Gain Setting	$G_{CH}$	Programmable, see ECG_GAIN[1:0]		20 to 160		V/V
ECG Channel Gain Error (Excluding Reference)		$V_{AVDD} = +1.8V$ , $G_{CH} = 20x$ , $ECGP = ECGN = V_{MID}$	-2.5		+2.5	%
		$V_{AVDD} = +1.1V$ , $G_{CH} = 20x$ , $ECGP = ECGN = V_{MID}$	-4.5		+4.5	%
ECG Channel Offset Error		(Note 4)		$\pm 0.1$		% of FSR
ADC Resolution				18		Bits
ADC Sample Rate		Programmable, see ECG_RATE[1:0]		125 to 512		SPS
CAPP to CAPN Impedance	$R_{HPF}$	$FHP = 1/(2\pi \times R_{HPF} \times C_{HPF})$ , $C_{HPF}$ = capacitance between CAPP and CAPN	320	450	630	k $\Omega$
Analog High-Pass Filter Slew Current		Fast recovery enabled (1.8V)		160		$\mu A$
		Fast recovery enabled (1.1V)		55		
		Fast recovery disabled		0.09		
Fast Settling Recovery Time		$C_{HPF} = 10\mu F$ , Note: varies by sample rate, see Table 3.		500		ms
Digital Low-Pass Filter		Linear phase FIR filter. ECG_RATE = 00, 01	DLPF[0:1] = 01		40	Hz
			DLPF[0:1] = 10		100	
			DLPF[0:1] = 11		150	
Digital High-Pass Filter		Phase-corrected 1st-order IIR filter. $DHPF = 1$		0.5		Hz
ECG Power Supply Rejection	PSRR	Lead bias disabled, DC		107		dB
		Lead bias disabled, $f = 64Hz$		110		

## Electrical Characteristics (continued)

( $V_{DVDD} = V_{AVDD} = +1.1V$  to  $+2.0V$ ,  $V_{OVDD} = +1.65V$  to  $+3.6V$ ,  $f_{CLK} = 32.768kHz$ ,  $LN\_BIOZ = 1$ ,  $T_A = T_{MIN}$  to  $T_{MAX}$ , unless otherwise noted. Typical values are at  $V_{DVDD} = V_{AVDD} = +1.8V$ ,  $V_{OVDD} = +2.5V$ ,  $T_A = +25^{\circ}C$ .) (Note 1)

PARAMETER	SYMBOL	CONDITIONS		MIN	TYP	MAX	UNITS
<b>ECG INPUT MUX</b>							
DC Lead Off Check		Pullup/ pulldown	IMAG[2:0] = 001		5		nA
			IMAG[2:0] = 010		10		
			IMAG[2:0] = 011		20		
			IMAG[2:0] = 100		50		
			IMAG[2:0] = 101		100		
DC Lead Off Comparator Low Threshold		VTH[1:0] = 11 (Note 5)			$V_{MID} - 0.50$		V
		VTH[1:0] = 10 (Note 6)			$V_{MID} - 0.45$		
		VTH[1:0] = 01 (Note 7)			$V_{MID} - 0.40$		
		VTH[1:0] = 00			$V_{MID} - 0.30$		
DC Lead Off Comparator High Threshold		VTH[1:0] = 11 (Note 5)			$V_{MID} + 0.50$		V
		VTH[1:0] = 10 (Note 6)			$V_{MID} + 0.45$		
		VTH[1:0] = 01 (Note 7)			$V_{MID} + 0.40$		
		VTH[1:0] = 00			$V_{MID} + 0.30$		
Lead Bias Impedance		Lead bias enabled	RBIASV[1:0] = 00		50		MΩ
			RBIASV[1:0] = 01		100		
			RBIASV[1:0] = 10		200		
Lead Bias Voltage	$V_{MID}$	Lead bias enabled			$V_{AVDD}/2.15$		V
Calibration Voltage Magnitude		Single-ended	$V_{MAG} = 0$		0.25		mV
			$V_{MAG} = 1$		0.50		
Calibration Voltage Magnitude Error		Single-ended (Note 8)		-7		+7	%
Calibration Voltage Frequency		Programmable, see FCAL[2:0]			0.0156 to 256		Hz
Calibration Voltage Pulse Time		Programmable, see THIGH[10:0]	FIFTY = 0		0.03052 to 62.474		ms
			FIFTY = 1		50		%

## Electrical Characteristics (continued)

( $V_{DVDD} = V_{AVDD} = +1.1V$  to  $+2.0V$ ,  $V_{OVDD} = +1.65V$  to  $+3.6V$ ,  $f_{CLK} = 32.768kHz$ ,  $LN\_BIOZ = 1$ ,  $T_A = T_{MIN}$  to  $T_{MAX}$ , unless otherwise noted. Typical values are at  $V_{DVDD} = V_{AVDD} = +1.8V$ ,  $V_{OVDD} = +2.5V$ ,  $T_A = +25^{\circ}C$ .) (Note 1)

PARAMETER	SYMBOL	CONDITIONS	MIN	TYP	MAX	UNITS
<b>BIOIMPEDANCE (BioZ) CHANNEL</b>						
Signal Generator Resolution		Square wave generator		1		Bits
DRVP/N Injected Full-Scale Current		BIOZ_HI_LOB = 1		8 to 96		$\mu A_{PK}$
	BIOZ_HI_LOB = 0	BIOZ_LC2X = 1		110 to 1100		$nA_{PK}$
		BIOZ_LC2X = 0		55 to 550		$nA_{PK}$
DRVP/N Injected Current Accuracy		BIOZ_HI_LOB = 1, Internal bias resistor, see EXT_RBIA5	-30		+30	%
		BIOZ_HI_LOB = 1, External bias resistor (0.1%, 10ppm, 324k $\Omega$ )	-10		+10	
		BIOZ_HI_LOB = 0		$\pm 10$		
DRVP/N Injected Current Power Supply Rejection		BIOZ_HI_LOB = 1		< $\pm 1$		%/V
		BIOZ_HI_LOB = 0		$\pm 16$		
DRVP/N Injected Current Temperature Coefficient		BIOZ_HI_LOB = 1, External bias resistor, 32 $\mu A_{PK}$ , 0 to 70 $^{\circ}C$ (0.1%, 10ppm, 324k $\Omega$ )		50		ppm/ $^{\circ}C$
		BIOZ_HI_LOB = 0		437		
DRVP/N Compliance Voltage		$V_{DRVP} - V_{DRVN}$		$\pm(V_{AVDD} - 0.5)$		$V_{P-P}$
Current Injection Frequency		Programmable, see BIOZ_FCGEN[3:0]		0.125 to 131.072		kHz
AC Differential Input Range		Shift from nominal gain < 1% ( $V_{AVDD} = 1.1V$ )		25		mV
		Shift from nominal gain < 1% ( $V_{AVDD} = 1.8V$ )		$\pm 90$		mV
BioZ Channel Gain		Programmable, see BIOZ_GAIN[1:0]		10 to 80		V/V
ADC Sample Rate		Programmable, see BIOZ_RATE		24.98 to 64		sps
ADC Resolution				20		Bits
Input Referred Noise (BIP, BIN)		BW = 0.05 to 4Hz, Gain = 20x		0.16		$\mu V_{RMS}$
		BW = 0.05 to 4Hz, Gain = 20x		1.1		$\mu V_{P-P}$
Impedance Resolution		0.1 to 4Hz, 32 $\mu A_{P-P}$ , 40kHz, Gain = 20x, $R_{BODY} = 680\Omega$		40		$\Omega_{P-P}$
		0.1 to 4Hz, 20nA $_{P-P}$ , 125Hz, Gain = 20x, $R_{BODY} = 172k\Omega$ , BIOZ_HI_LOB = 0		74		
Input Analog High Pass Filter		Programmable, see BIOZ_AHPF[2:0]		60 to 4000		Hz
Demodulation Phase Range		Programmable, see BIOZ_PHOFF[3:0]		0 to 168.75		$^{\circ}$

## Electrical Characteristics (continued)

( $V_{DVDD} = V_{AVDD} = +1.1V$  to  $+2.0V$ ,  $V_{OVDD} = +1.65V$  to  $+3.6V$ ,  $f_{CLK} = 32.768kHz$ ,  $LN\_BIOZ = 1$ ,  $T_A = T_{MIN}$  to  $T_{MAX}$ , unless otherwise noted. Typical values are at  $V_{DVDD} = V_{AVDD} = +1.8V$ ,  $V_{OVDD} = +2.5V$ ,  $T_A = +25^{\circ}C$ .) (Note 1)

PARAMETER	SYMBOL	CONDITIONS	MIN	TYP	MAX	UNITS
Demodulation Phase Resolution				11.25		°
Output Digital Low Pass Filter		BIOZ_DLPF[1:0] = 01		4		Hz
		BIOZ_DLPF[1:0] = 10		8		
		BIOZ_DLPF[1:0] = 11		16		
Output Digital High Pass Filter		BIOZ_DHPF[1:0] = 01		0.05		Hz
		BIOZ_DHPF[1:0] = 1x		0.5		Hz
<b>BIOIMPEDANCE (BioZ) INPUT MUX</b>						
DC Lead Off Check		IMAG[2:0] = 001		5		nA
		IMAG[2:0] = 010		10		
		IMAG[2:0] = 011		20		
		IMAG[2:0] = 100		50		
		IMAG[2:0] = 101		100		
DC Lead Off Comparator Low Threshold		DCLOFF_VTH[1:0] = 11 (Note 5)		$V_{MID} - 0.50$		V
		DCLOFF_VTH[1:0] = 10 (Note 6)		$V_{MID} - 0.45$		
		DCLOFF_VTH[1:0] = 01 (Note 7)		$V_{MID} - 0.40$		
		DCLOFF_VTH[1:0] = 00		$V_{MID} - 0.30$		
DC Lead Off Comparator High Threshold		DCLOFF_VTH[1:0] = 11 (Note 5)		$V_{MID} + 0.50$		V
		DCLOFF_VTH[1:0] = 10 (Note 6)		$V_{MID} + 0.45$		
		DCLOFF_VTH[1:0] = 01 (Note 7)		$V_{MID} + 0.40$		
		DCLOFF_VTH[1:0] = 00		$V_{MID} + 0.30$		
Lead Bias Impedance		Lead bias enabled, RBIASV[1:0] = 00		50		MΩ
		Lead bias enabled, RBIASV[1:0] = 01		100		
		Lead bias enabled, RBIASV[1:0] = 10		200		
Lead Bias Voltage	$V_{MID}$	Lead bias enabled.		$V_{AVDD}/2.15$		V
Calibration Voltage Magnitude		Single-ended. $V_{MAG} = 0$		0.25		mV
		Single-ended. $V_{MAG} = 1$		0.50		
Calibration Voltage Error		Single-ended. (Note 8)	-7		+7	%
Calibration Voltage Frequency		Programmable, see FCAL[2:0]		0.0156 to 256		Hz
Calibration Voltage Pulse Time		Programmable, see THIGH[10:0]	FIFTY = 0	0.03052 to 62.474		ms
			FIFTY = 1	50		%

**Electrical Characteristics (continued)**

( $V_{DVDD} = V_{AVDD} = +1.1V$  to  $+2.0V$ ,  $V_{OVDD} = +1.65V$  to  $+3.6V$ ,  $f_{FCLK} = 32.768kHz$ ,  $LN\_BIOZ = 1$ ,  $T_A = T_{MIN}$  to  $T_{MAX}$ , unless otherwise noted. Typical values are at  $V_{DVDD} = V_{AVDD} = +1.8V$ ,  $V_{OVDD} = +2.5V$ ,  $T_A = +25^\circ C$ .) (Note 1)

PARAMETER	SYMBOL	CONDITIONS	MIN	TYP	MAX	UNITS
Resistive Load Nominal Value	$R_{VAL}$	Programmable, see BMUX_RNOM[2:0]	0.625 to 5.0			k $\Omega$
Resistive Load Modulation Value	$R_{MOD}$	Programmable, see BMUX_RMOD[2:0]	15 to 2960			m $\Omega$
Resistive Load Modulation Frequency	$f_{MOD}$	Programmable, see BMUX_FBIST[1:0]	0.625 to 4.0			Hz
<b>INTERNAL REFERENCE/Common-Mode</b>						
$V_{BG}$ Output Voltage	$V_{BG}$		0.650			V
$V_{BG}$ Output Impedance			100			k $\Omega$
External $V_{BG}$ Compensation Capacitor	$C_{VBG}$		1			$\mu F$
$V_{REF}$ Output Voltage	$V_{REF}$	$T_A = +25^\circ C$	0.995	1.000	1.005	V
$V_{REF}$ Temperature Coefficient	$TC_{REF}$	$T_A = 0^\circ C$ to $+70^\circ C$	10			ppm/ $^\circ C$
$V_{REF}$ Buffer Line Regulation			330			$\mu V/V$
$V_{REF}$ Buffer Load Regulation		$I_{LOAD} = 0$ to $100\mu A$	25			$\mu V/\mu A$
External $V_{REF}$ Compensation Capacitor	$C_{REF}$		1	10		$\mu F$
$V_{CM}$ Output Voltage	$V_{CM}$		0.650			V
External $V_{CM}$ Compensation Capacitor	$C_{CM}$		1	10		$\mu F$
<b>DIGITAL INPUTS (SDI, SCLK, CSB, FCLK)</b>						
Input-Voltage High	$V_{IH}$		$0.7 \times V_{OVDD}$			V
Input-Voltage Low	$V_{IL}$		$0.3 \times V_{OVDD}$			V
Input Hysteresis	$V_{HYS}$		$0.05 \times V_{OVDD}$			V
Input Capacitance	$C_{IN}$		10			pF
Input Current	$I_{IN}$		-1		+1	$\mu A$
<b>DIGITAL OUTPUTS (SDO, INTB, INT2B)</b>						
Output Voltage High	$V_{OH}$	$I_{SOURCE} = 1mA$	$V_{OVDD} - 0.4$			V
Output Voltage Low	$V_{OL}$	$I_{SINK} = 1mA$	0.4			V
Three-State Leakage Current			-1		+1	$\mu A$
Three-State Output Capacitance			15			pF



**Electrical Characteristics (continued)**

(V<sub>DVDD</sub> = V<sub>AVDD</sub> = +1.1V to +2.0V, V<sub>OVDD</sub> = +1.65V to +3.6V, f<sub>FCLK</sub> = 32.768kHz, LN\_BIOZ = 1, T<sub>A</sub> = T<sub>MIN</sub> to T<sub>MAX</sub>, unless otherwise noted. Typical values are at V<sub>DVDD</sub> = V<sub>AVDD</sub> = +1.8V, V<sub>OVDD</sub> = +2.5V, T<sub>A</sub> = +25°C.) (Note 1)

PARAMETER	SYMBOL	CONDITIONS	MIN	TYP	MAX	UNITS	
<b>POWER SUPPLY</b>							
Analog Supply Voltage	V <sub>AVDD</sub>	Connect AVDD to DVDD	1.1		2.0	V	
Digital Supply Voltage	V <sub>DVDD</sub>	Connect DVDD to AVDD	1.1		2.0	V	
Interface Supply Voltage	V <sub>OVDD</sub>	Power for I/O drivers only	1.65		3.6	V	
Supply Current	I <sub>AVDD</sub> + I <sub>DVDD</sub>	ECG channel	V <sub>AVDD</sub> = V <sub>DVDD</sub> = +1.1V	76			
			V <sub>AVDD</sub> = V <sub>DVDD</sub> = +1.8V	95			
			V <sub>AVDD</sub> = V <sub>DVDD</sub> = +2.0V	102	120		
		ECG and BioZ, BIOZ_HI_LOB = 0 LN_BIOZ = 0	V <sub>AVDD</sub> = V <sub>DVDD</sub> = +1.1V	152			
			V <sub>AVDD</sub> = V <sub>DVDD</sub> = +1.8V	175			
			V <sub>AVDD</sub> = V <sub>DVDD</sub> = +2.0V	184	230		
		ECG and BioZ, BIOZ_HI_LOB = 0 LN_BIOZ = 1	V <sub>AVDD</sub> = V <sub>DVDD</sub> = +1.1V	167			
			V <sub>AVDD</sub> = V <sub>DVDD</sub> = +1.8V	190			
			V <sub>AVDD</sub> = V <sub>DVDD</sub> = +2.0V	198	245		
		ECG and BioZ, BIOZ_HI_LOB = 1 LN_BIOZ = 0	V <sub>AVDD</sub> = V <sub>DVDD</sub> = +1.1V	186			
			V <sub>AVDD</sub> = V <sub>DVDD</sub> = +1.8V	211			
			V <sub>AVDD</sub> = V <sub>DVDD</sub> = +2.0V	220			
		ECG and BioZ, BIOZ_HI_LOB = 1 LN_BIOZ = 1	V <sub>AVDD</sub> = V <sub>DVDD</sub> = +1.1V	200			
			V <sub>AVDD</sub> = V <sub>DVDD</sub> = +1.8V	225			
			V <sub>AVDD</sub> = V <sub>DVDD</sub> = +2.0V	235			
		BioZ channel, BIOZ_HI_LOB = 0 LN_BIOZ = 0	V <sub>AVDD</sub> = V <sub>DVDD</sub> = +1.1V	110			
			V <sub>AVDD</sub> = V <sub>DVDD</sub> = +1.8V	126			
			V <sub>AVDD</sub> = V <sub>DVDD</sub> = +2.0V	133			
		BioZ channel, BIOZ_HI_LOB = 0 LN_BIOZ = 1	V <sub>AVDD</sub> = V <sub>DVDD</sub> = +1.1V	124			
			V <sub>AVDD</sub> = V <sub>DVDD</sub> = +1.8V	141			
			V <sub>AVDD</sub> = V <sub>DVDD</sub> = +2.0V	147			
		BioZ channel, BIOZ_HI_LOB = 1 LN_BIOZ = 0	V <sub>AVDD</sub> = V <sub>DVDD</sub> = +1.1V	144			
			V <sub>AVDD</sub> = V <sub>DVDD</sub> = +1.8V	163			
			V <sub>AVDD</sub> = V <sub>DVDD</sub> = +2.0V	170			
BioZ channel, BIOZ_HI_LOB = 1 LN_BIOZ = 1	V <sub>AVDD</sub> = V <sub>DVDD</sub> = +1.1V	158					
	V <sub>AVDD</sub> = V <sub>DVDD</sub> = +1.8V	178					
	V <sub>AVDD</sub> = V <sub>DVDD</sub> = +2.0V	185					
ULP Lead On Detect	T <sub>A</sub> = +70°C			1.3			
	T <sub>A</sub> = +25°C			0.63	2.5		

## Timing Characteristics (Note 2)

( $V_{DVDD} = V_{AVDD} = +1.1V$  to  $+2.0V$ ,  $V_{OVDD} = +1.65V$  to  $+3.6V$ ,  $f_{CLK} = 32.768kHz$ ,  $LN\_BIOZ = 1$ ,  $T_A = T_{MIN}$  to  $T_{MAX}$ , unless otherwise noted. Typical values are at  $V_{DVDD} = V_{AVDD} = +1.8V$ ,  $V_{OVDD} = +2.5V$ ,  $T_A = +25^\circ C$ .) (Note 1)

PARAMETER	SYMBOL	CONDITIONS	MIN	TYP	MAX	UNITS
Interface Supply Current	$I_{OVDD}$	$V_{OVDD} = +1.65V$ , ECG channel at 512sps (Note 9)		0.2		$\mu A$
		$V_{OVDD} = 3.6V$ , ECG channel at 512sps (Note 9)		0.6	1.6	
Shutdown Current	$I_{SAVDD} + I_{SDVDD}$	$V_{AVDD} = V_{DVDD} = 2.0V$ (Note 4)	$T_A = +70^\circ C$	1.3		$\mu A$
			$T_A = +25^\circ C$	0.58	2.5	
	$I_{SOVDD}$	$V_{OVDD} = 3.6V$ , $V_{AVDD} = V_{DVDD} = 2.0V$			1.1	
<b>ESD PROTECTION</b>						
ECGP, ECGN, BIP, BIN		IEC 61000-4-2 Contact Discharge (Note 10)		$\pm 8$		kV
		IEC 61000-4-2 Air-Gap Discharge (Note 10)		$\pm 15$		
All Other Pins		JEDEC JESD22-A114 HBM Transient Pulse		$\pm 2.5$		kV
<b>TIMING CHARACTERISTICS (NOTE 2)</b>						
SCLK Frequency	$f_{SCLK}$		0		12	MHz
SCLK Period	$t_{CP}$		83			ns
SCLK Pulse Width High	$t_{CH}$		15			ns
SCLK Pulse Width Low	$t_{CL}$		15			ns
CSB Fall to SCLK Rise Setup Time	$t_{CSS0}$	To 1st SCLK rising edge (RE)	15			ns
CSB Fall to SCLK Rise Hold Time	$t_{CSH0}$	Applies to inactive RE preceding 1st RE	0			ns
CSB Rise to SCLK Rise Hold Time	$t_{CSH1}$	Applies to 32nd RE, executed write	10			ns
CSB Rise to SCLK Rise	$t_{CSA}$	Applies to 32nd RE, aborted write sequence	15			ns
SCLK Rise to CSB Fall	$t_{CSF}$	Applies to 32nd RE	100			ns
CSB Pulse-Width High	$t_{CSPW}$		20			ns
SDI-to-SCLK Rise Setup Time	$t_{DS}$		8			ns
SDI to SCLK Rise Hold Time	$t_{DH}$		8			ns
SCLK Fall to SDO Transition	$t_{DOT}$	$C_{LOAD} = 20pF$			40	ns
		$C_{LOAD} = 20pF$ , $V_{AVDD} = V_{DVDD} \geq 1.8V$ , $V_{OVDD} \geq 2.5V$			20	ns
SCLK Fall to SDO Hold	$t_{DOH}$	$C_{LOAD} = 20pF$	2			ns
CSB Fall to SDO Fall	$t_{DOE}$	Enable time, $C_{LOAD} = 20pF$			30	ns
CSB Rise to SDO Hi-Z	$t_{DOZ}$	Disable time			35	ns

Timing Characteristics (Note 2)

( $V_{DVDD} = V_{AVDD} = +1.1V$  to  $+2.0V$ ,  $V_{OVDD} = +1.65V$  to  $+3.6V$ ,  $f_{FCLK} = 32.768kHz$ ,  $LN\_BIOZ = 1$ ,  $T_A = T_{MIN}$  to  $T_{MAX}$ , unless otherwise noted. Typical values are at  $V_{DVDD} = V_{AVDD} = +1.8V$ ,  $V_{OVDD} = +2.5V$ ,  $T_A = +25^{\circ}C$ .) (Note 1)

PARAMETER	SYMBOL	CONDITIONS	MIN	TYP	MAX	UNITS
FCLK Frequency	$f_{FCLK}$	External reference clock		32.768		kHz
FCLK Period	$t_{FP}$			30.52		$\mu s$
FCLK Pulse-Width High	$t_{FH}$	50% duty cycle assumed		15.26		$\mu s$
FCLK Pulse-Width Low	$t_{FL}$	50% duty cycle assumed		15.26		$\mu s$

- Note 1:** All devices are 100% production tested at  $T_A = +25^{\circ}C$ . Specifications over the operating temperature range and relevant supply voltage range are guaranteed by design and characterization.
- Note 2:** Guaranteed by design and characterization. Not tested in production.
- Note 3:** One electrode drive with  $<10\Omega$  source impedance, the other driven with  $51k\Omega$  in parallel with a  $47nF$  per IEC60601-2-47.
- Note 4:** Inputs connected to  $51k\Omega$  in parallel with a  $47nF$  to  $V_{CM}$ .
- Note 5:** Use this setting only for  $V_{AVDD} = V_{DVDD} \geq 1.65V$ .
- Note 6:** Use this setting only for  $V_{AVDD} = V_{DVDD} \geq 1.55V$ .
- Note 7:** Use this setting only for  $V_{AVDD} = V_{DVDD} \geq 1.45V$ .
- Note 8:** This specification defines the accuracy of the calibration voltage source as applied to the ECG input, not as measured through the ADC channel.
- Note 9:**  $f_{SCLK} = 4MHz$ , burst mode,  $EFIT = 8$ ,  $C_{SDO} = C_{INTB} = 50pF$ .
- Note 10:** ESD test performed with  $1k\Omega$  series resistor designed to withstand  $8kV$  surge voltage.

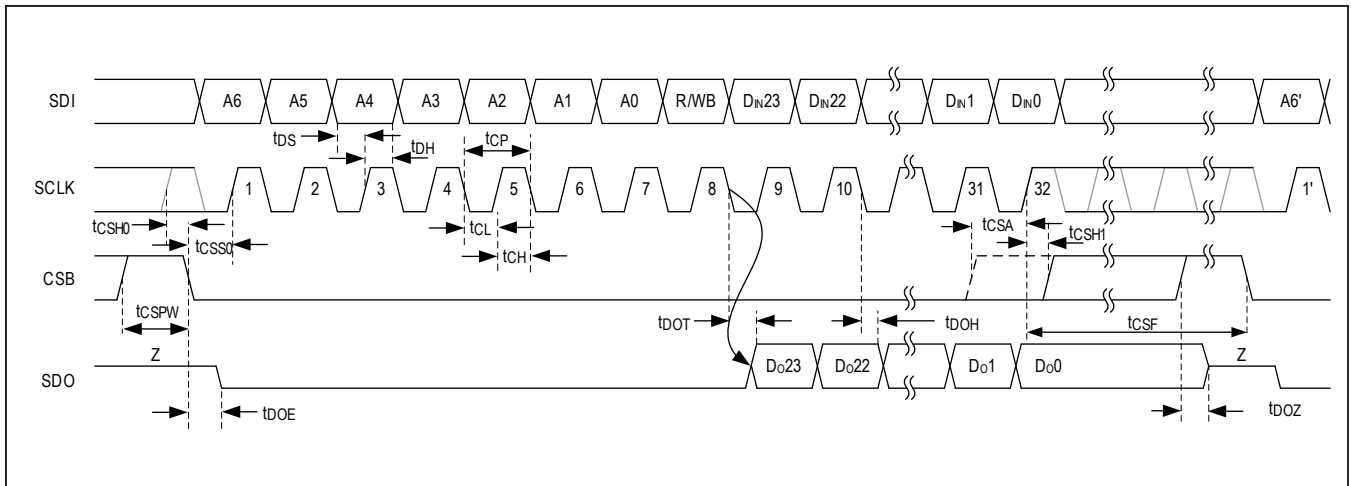

Figure 1a. SPI Timing Diagram

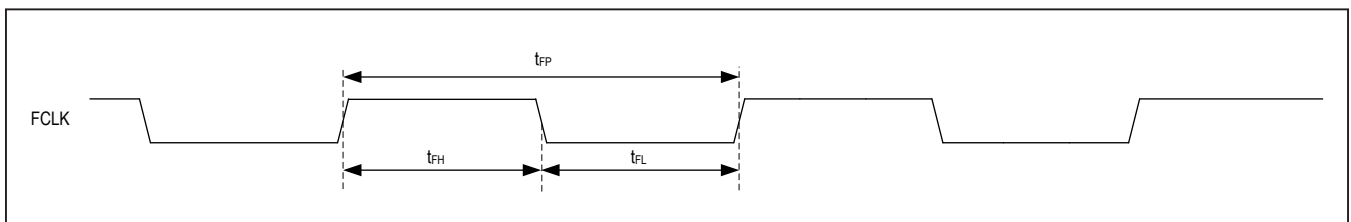
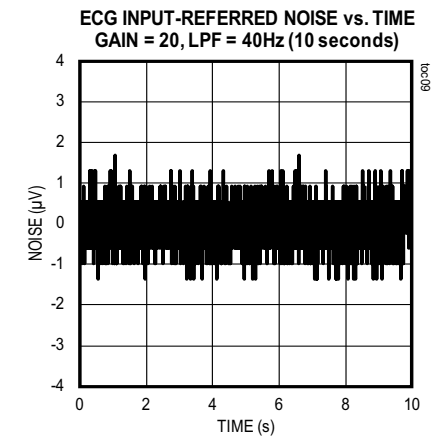
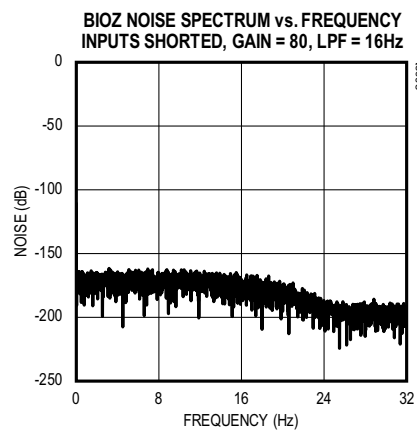
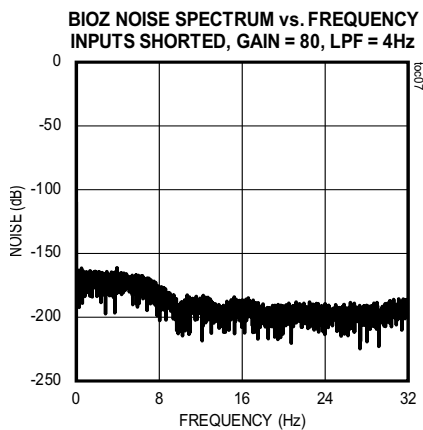
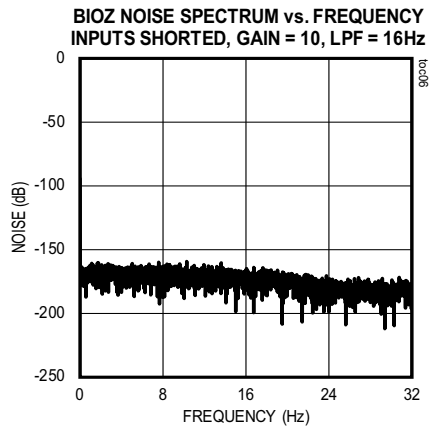
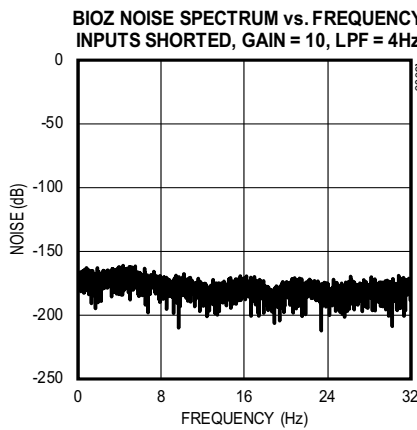
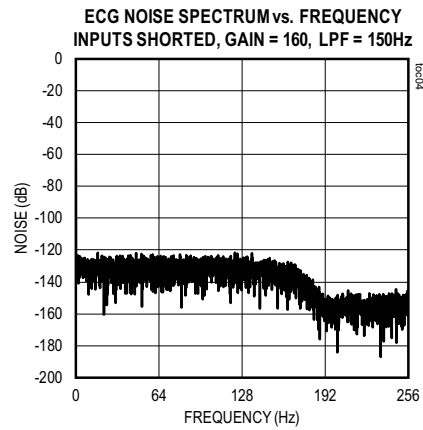
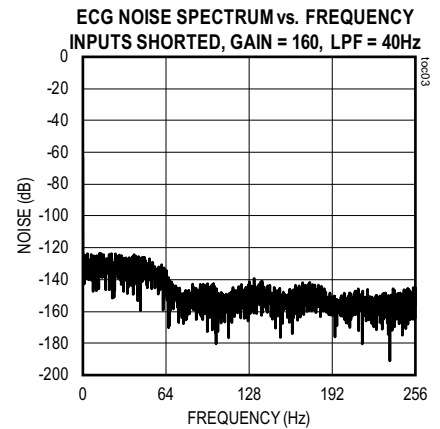
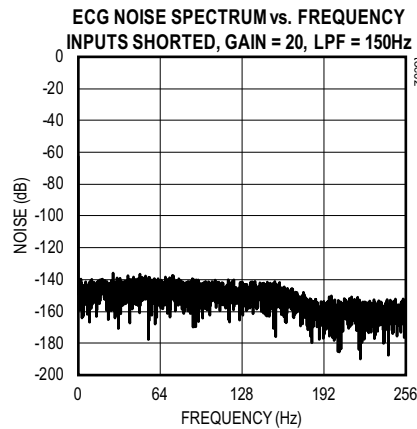
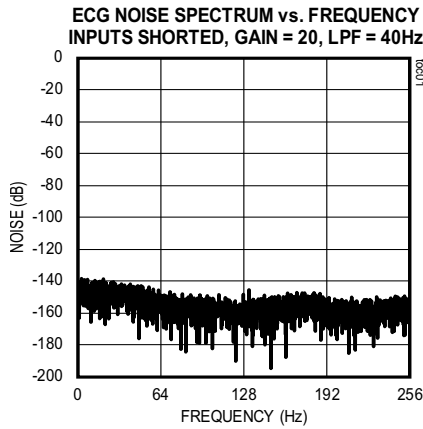

Figure 1b. FCLK Timing Diagram

Typical Operating Characteristics

( $V_{DVDD} = V_{AVDD} = 1.8V$ ,  $V_{OVDD} = 2.5V$ ,  $T_A = +25^\circ C$ , unless otherwise noted.)



Typical Operating Characteristics (continued)

( $V_{DVDD} = V_{AVDD} = 1.8V$ ,  $V_{OVDD} = 2.5V$ ,  $T_A = +25^\circ C$ , unless otherwise noted.)

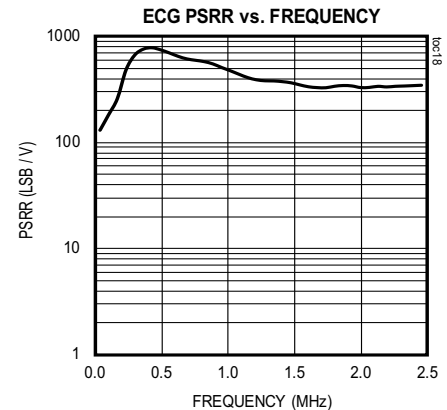
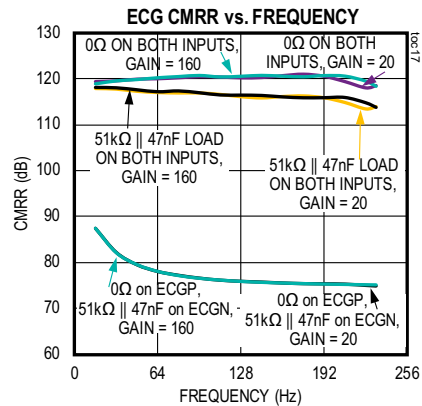
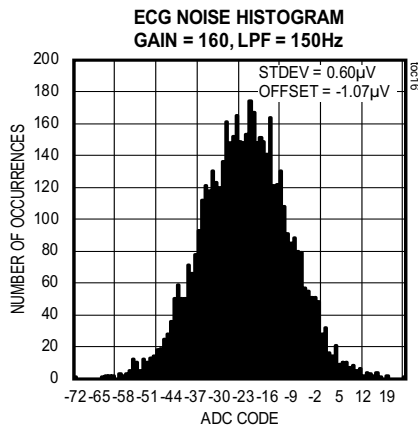
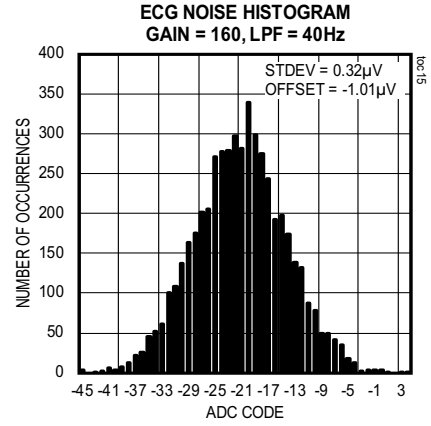
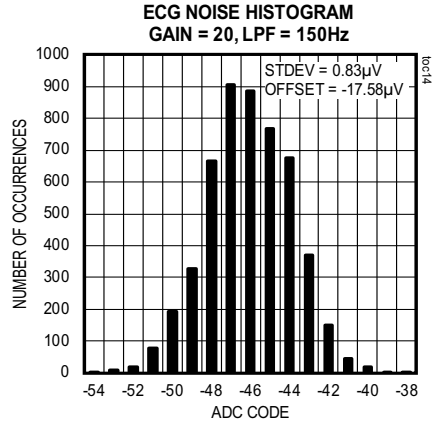
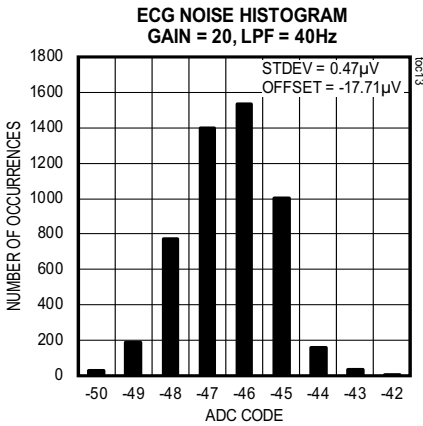
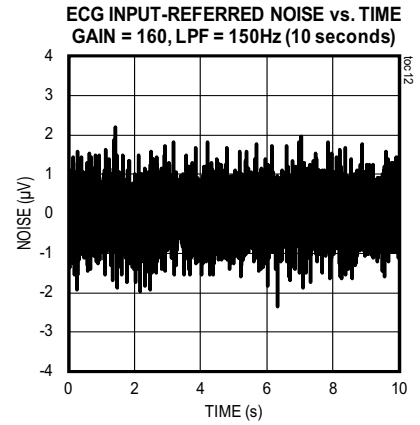
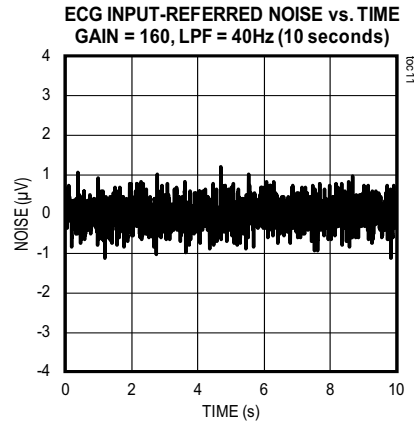
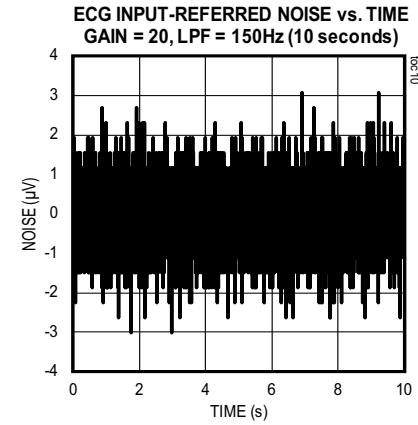

Typical Operating Characteristics (continued)

( $V_{DVDD} = V_{AVDD} = 1.8V$ ,  $V_{OVDD} = 2.5V$ ,  $T_A = +25^\circ C$ , unless otherwise noted.)

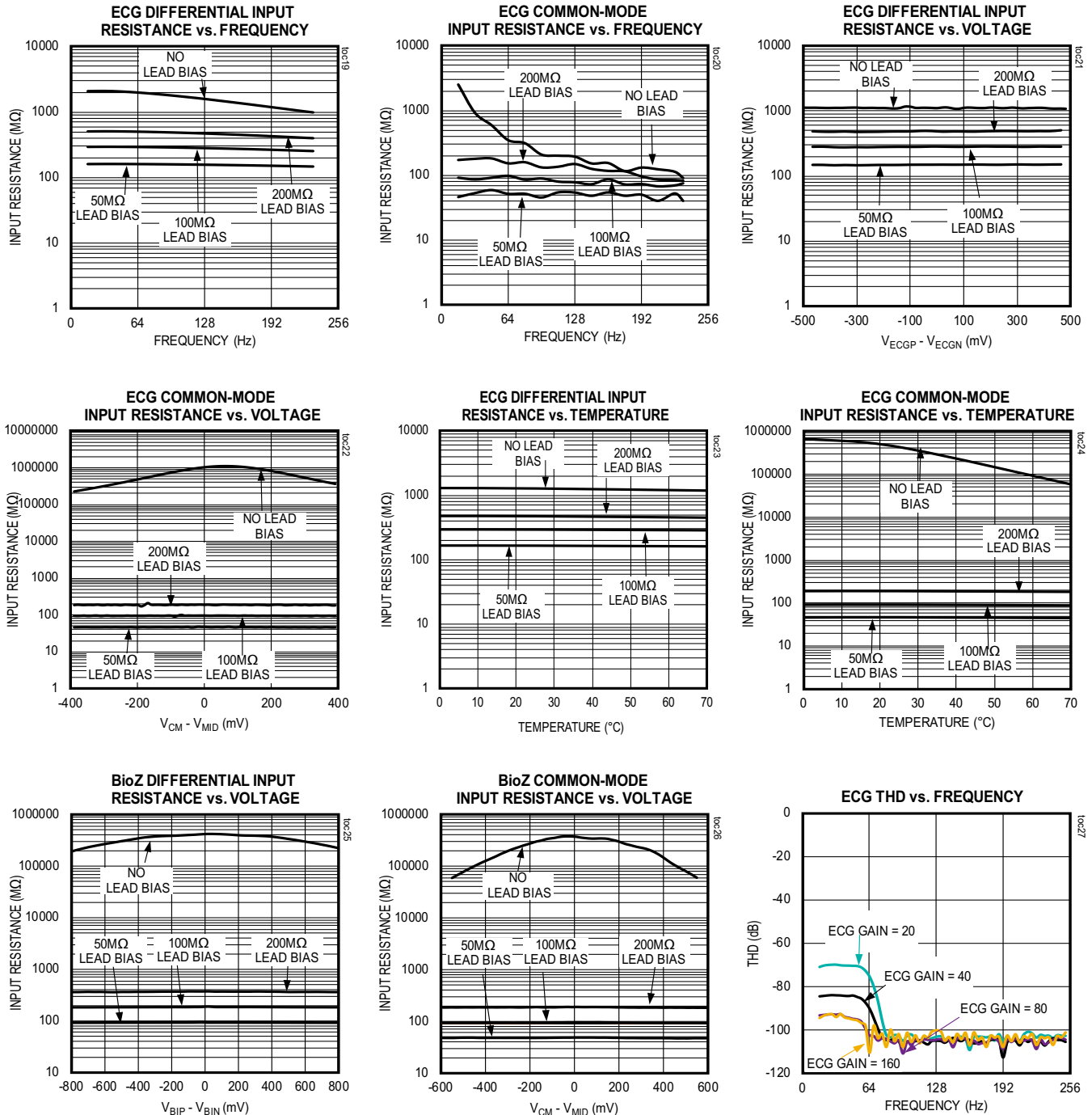

Typical Operating Characteristics (continued)

( $V_{DVDD} = V_{AVDD} = 1.8V$ ,  $V_{OVDD} = 2.5V$ ,  $T_A = +25^\circ C$ , unless otherwise noted.)

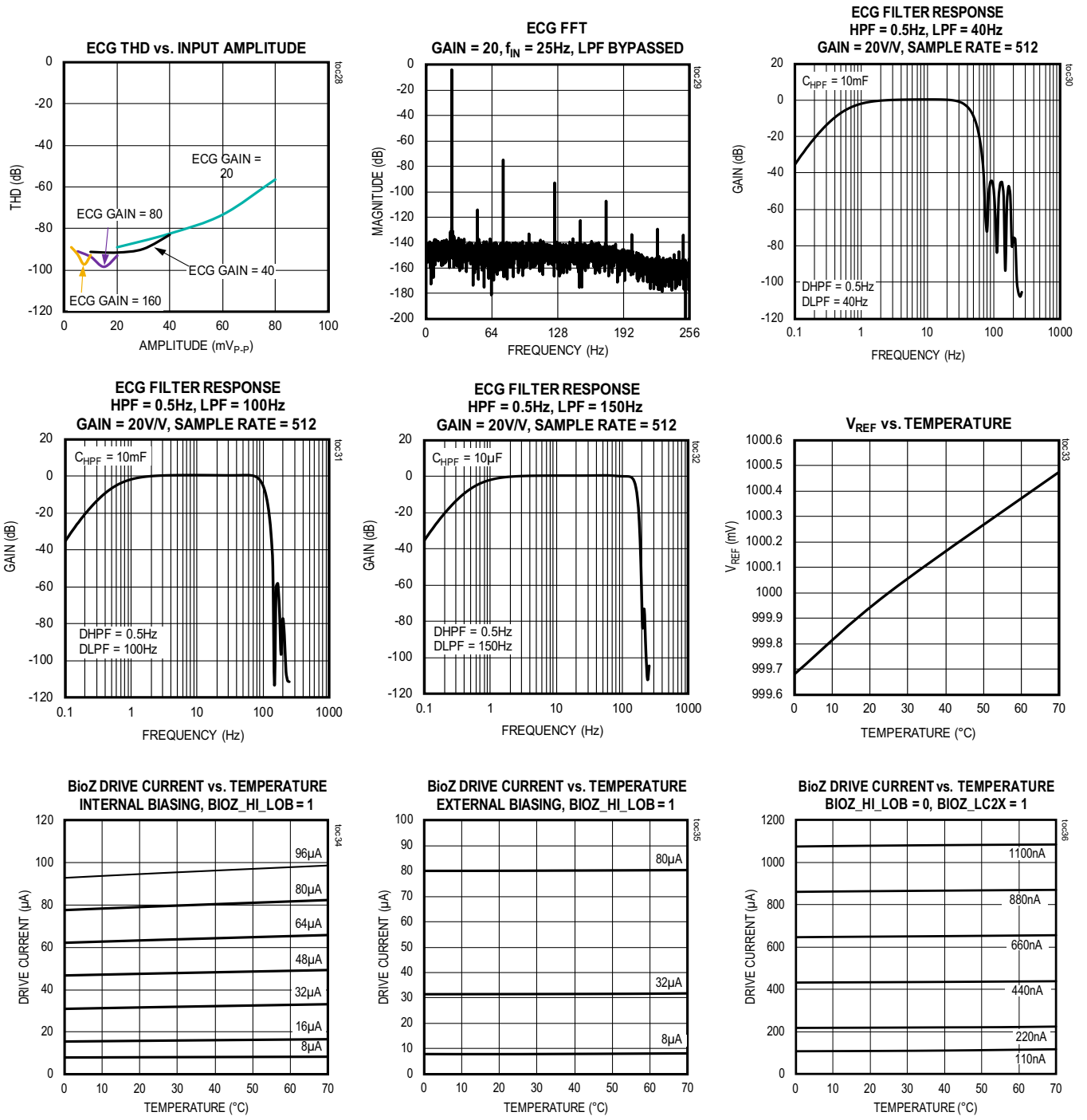

Typical Operating Characteristics (continued)

( $V_{DVDD} = V_{AVDD} = 1.8V$ ,  $V_{OVDD} = 2.5V$ ,  $T_A = +25^\circ C$ , unless otherwise noted.)

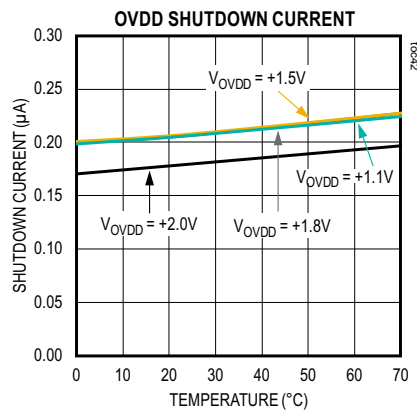
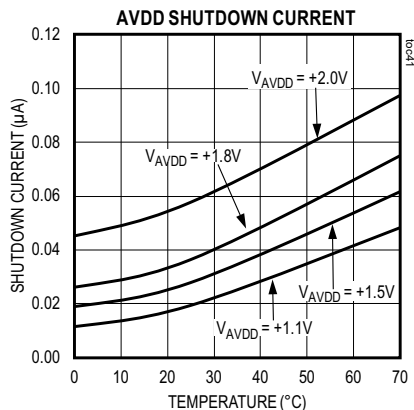
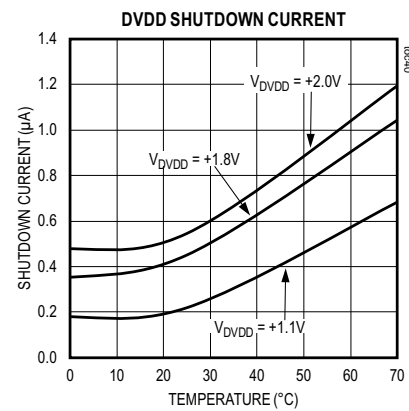
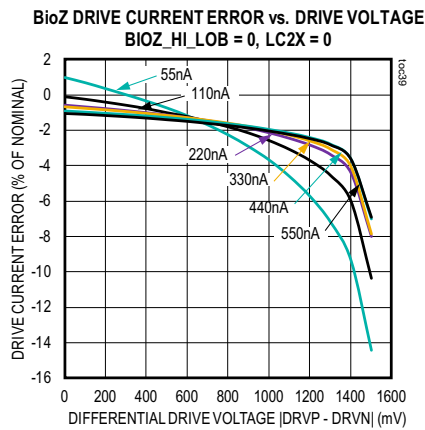
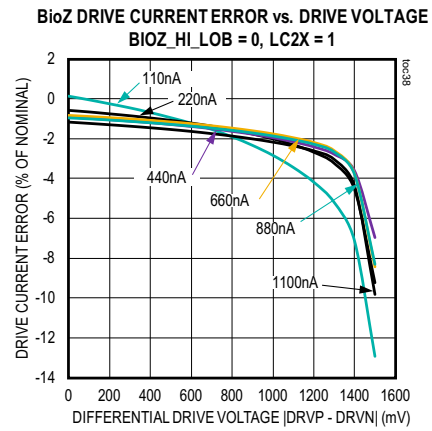
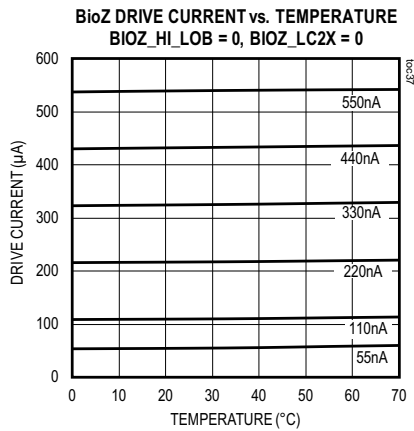



Typical Operating Characteristics (continued)

( $V_{DVDD} = V_{AVDD} = 1.8V$ ,  $V_{OVDD} = 2.5V$ ,  $T_A = +25^\circ C$ , unless otherwise noted.)

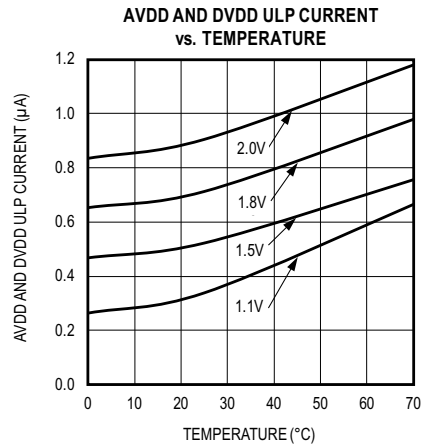
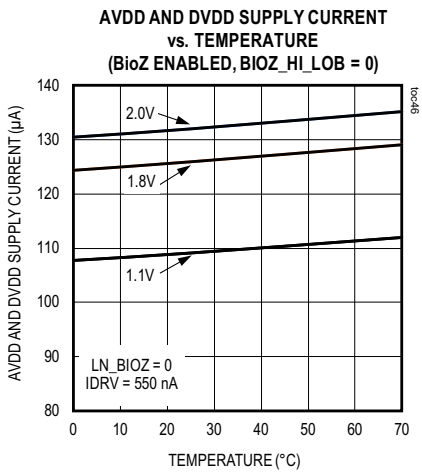
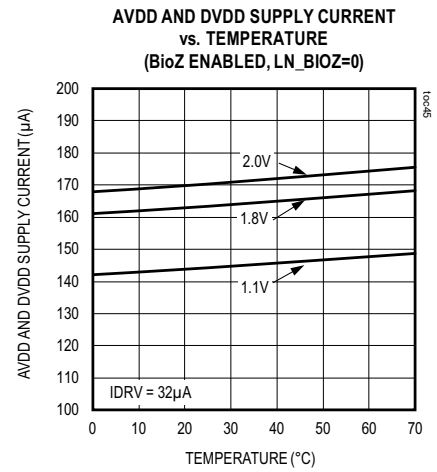
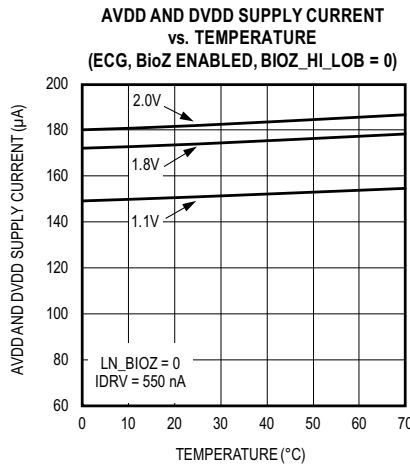
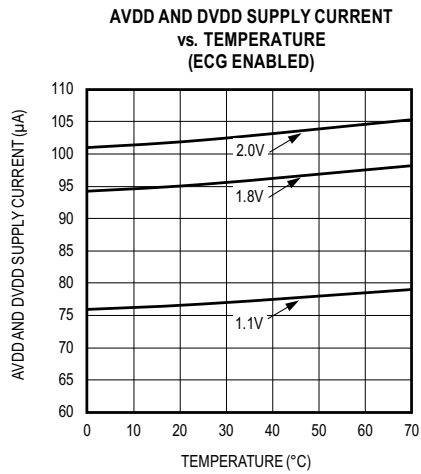

Typical Operating Characteristics (continued)

( $V_{DVDD} = V_{AVDD} = 1.8V$ ,  $V_{OVDD} = 2.5V$ ,  $T_A = +25^{\circ}C$ , unless otherwise noted.)

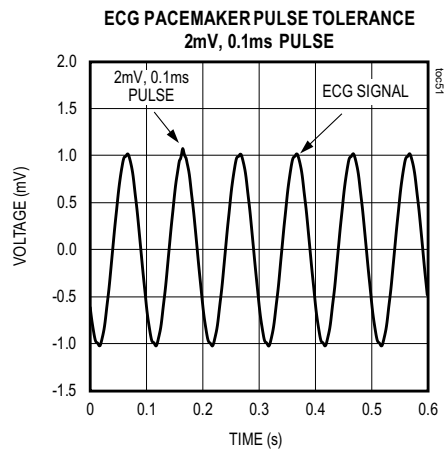
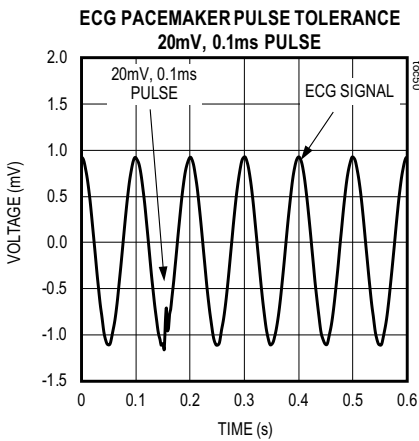
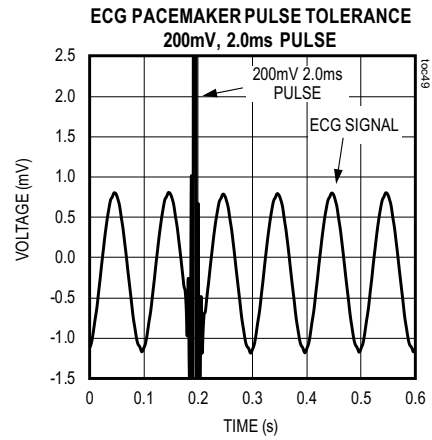
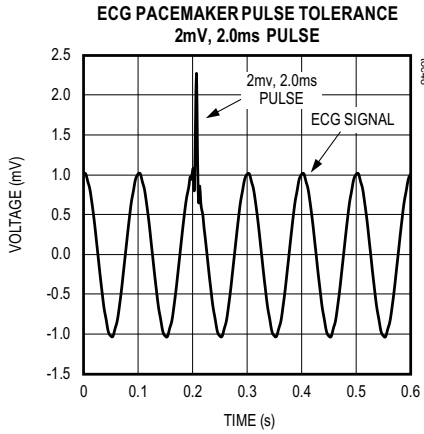

Pin Configuration

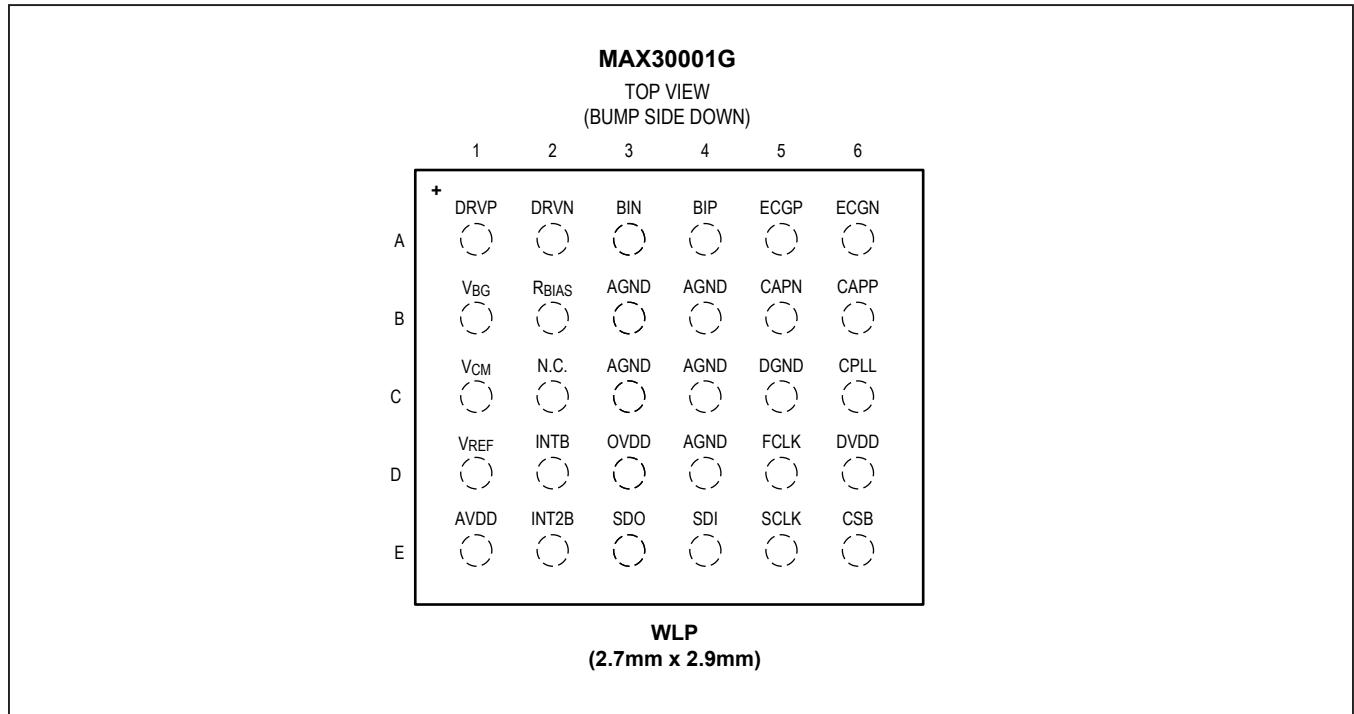

Pin Description

BUMP	NAME	FUNCTION
WLP		
A1	DRVP	Positive Output Current Source for Bio-Impedance Excitation. Requires a series capacitor between pin and electrode.
A2	DRVN	Negative Output Current Source for Bio-Impedance Excitation. Requires a series capacitor between pin and electrode.
A3	BIN	Bioimpedance Negative Input.
A4	BIP	Bioimpedance Positive Input.
A5	ECGP	ECG Positive Input.
A6	ECGN	ECG Negative Input.
B1	V <sub>BG</sub>	Bandgap Noise Filter Output. Connect a 1.0µF X7R ceramic capacitor between V <sub>BG</sub> and AGND.
B2	R <sub>BIAS</sub>	External Resistor Bias. Connect a low tempco resistor between R <sub>BIAS</sub> and AGND. If external bias generator is not used then R <sub>BIAS</sub> can be left floating.
B3, B4, C3, C4, D4	AGND	Analog Power and Reference Ground. Connect into the printed circuit board ground plane.
B5	CAPN	Analog High-Pass Filter Input. Connect a 1µF X7R capacitor (C <sub>H<sub>PF</sub></sub> ) between CAPP and CAPN to form a 0.5Hz high-pass response in the ECG channel. <i>Select a capacitor with a high voltage rating (25V) to improve linearity of the ECG signal path.</i>

## Pin Description (continued)

BUMP	NAME	FUNCTION
WLP		
B6	CAPP	Analog High-Pass Filter Input. Connect a 1 $\mu$ F X7R capacitor ( $C_{HPF}$ ) between CAPP and CAPN to form a 0.5Hz high-pass response in the ECG channel. <i>Select a capacitor with a high voltage rating (25V) to improve linearity of the ECG signal path.</i>
C1	V <sub>CM</sub>	Common Mode Buffer Output. Connect a 10 $\mu$ F X5R ceramic capacitor between V <sub>CM</sub> and AGND.
C2	N.C.	No Connection. Leave unconnected.
C5	DGND	Digital Ground for Both Digital Core and I/O Pad Drivers. Recommended to connect to AGND plane.
C6	CPLL	PLL Loop Filter Input. Connect 1nF C0G ceramic capacitor between CPLL and AGND.
D1	V <sub>REF</sub>	ADC Reference Buffer Output. Connect a 10 $\mu$ F X7R ceramic capacitor between V <sub>REF</sub> and AGND.
D2	INTB	Interrupt Output. INTB is an active low status output. It can be used to interrupt an external device.
D3	OVDD	Logic Interface Supply Voltage.
D5	FCLK	External 32.768kHz Clock that Controls the Sampling of the Internal Sigma-Delta Converters and Decimator.
D6	DVDD	Digital Core Supply voltage. Connect to AVDD.
E1	AVDD	Analog Core Supply Voltage. Connect to DVDD.
E2	INT2B	Interrupt 2 Output. INT2B is an active-low status output. It can be used to interrupt an external device.
E3	SDO	Serial Data Output. SDO will change state on the falling edge of SCLK when CSB is low. SDO is three-stated when CSB is high.
E4	SDI	Serial Data Input. SDI is sampled into the device on the rising edge of SCLK when CSB is low.
E5	SCLK	Serial Clock Input. Clocks data in and out of the serial interface when CSB is low.
E6	CSB	Active-Low Chip-Select Input. Enables the serial interface.

## Detailed Description

### ECG Channel

Figure 2 illustrates the ECG channel block diagram, excluding the ADC. The channel comprises an input MUX, a fast-recovering instrumentation amplifier, an anti-alias filter, and a programmable gain amplifier. The input MUX includes several features such as ESD protection, EMI filtering, lead biasing, leads off checking, and ultra-low power leads-on checking. The output of this analog channel drives an 18-bit Sigma-Delta ADC.

### Input MUX

The ECG input MUX shown in Figure 3 contains integrated ESD and EMI protection, DC leads off detect current sources, lead-on detect, series isolation switches, lead biasing, and a programmable calibration voltage source to enable channel built-in self-test.

### EMI Filtering and ESD Protection

EMI filtering of the ECGP and ECGN inputs consists of a single pole, low pass, differential, and common mode filter with the pole located at approximately 26MHz. The ECGP and ECGN inputs also have input clamps that protect the inputs from ESD events.

- $\pm 8\text{kV}$  using the Contact Discharge method specified in IEC61000-4-2 ESD
- $\pm 15\text{kV}$  using the Air Gap Discharge method specified in IEC61000-4-2 ESD
- For IEC61000-4-2 ESD protection, use  $1\text{k}\Omega$  series resistors on ECGP and ECGN that are rated to withstand  $\pm 8\text{kV}$  surge voltages.

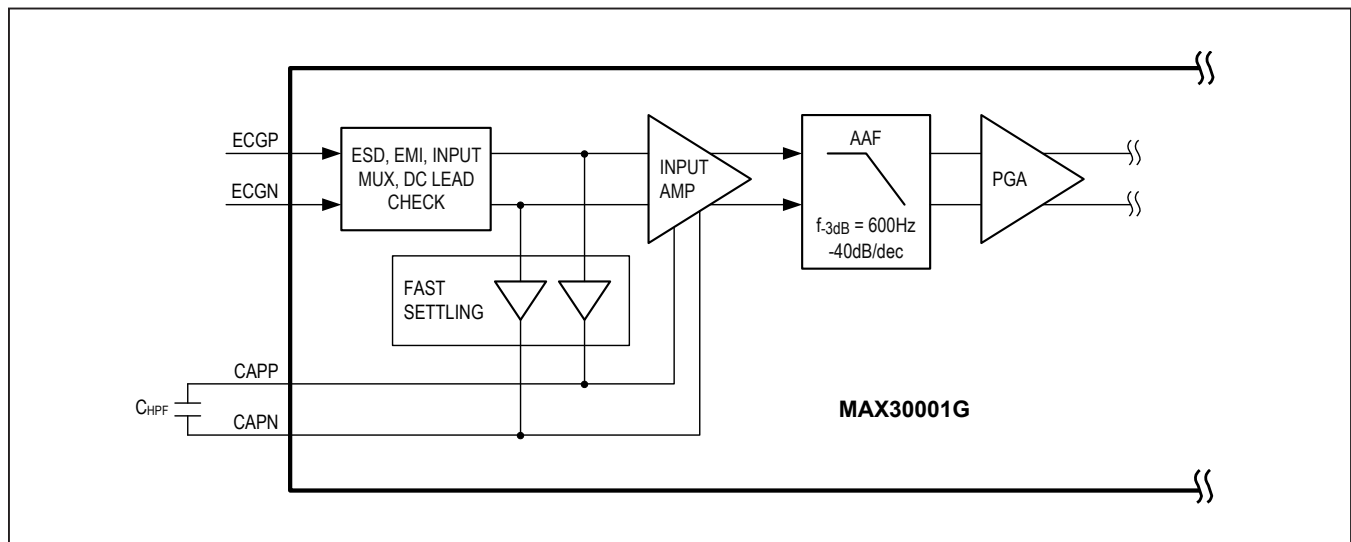

Figure 2. ECG Channel Input Amplifier and PGA Excluding the ADC

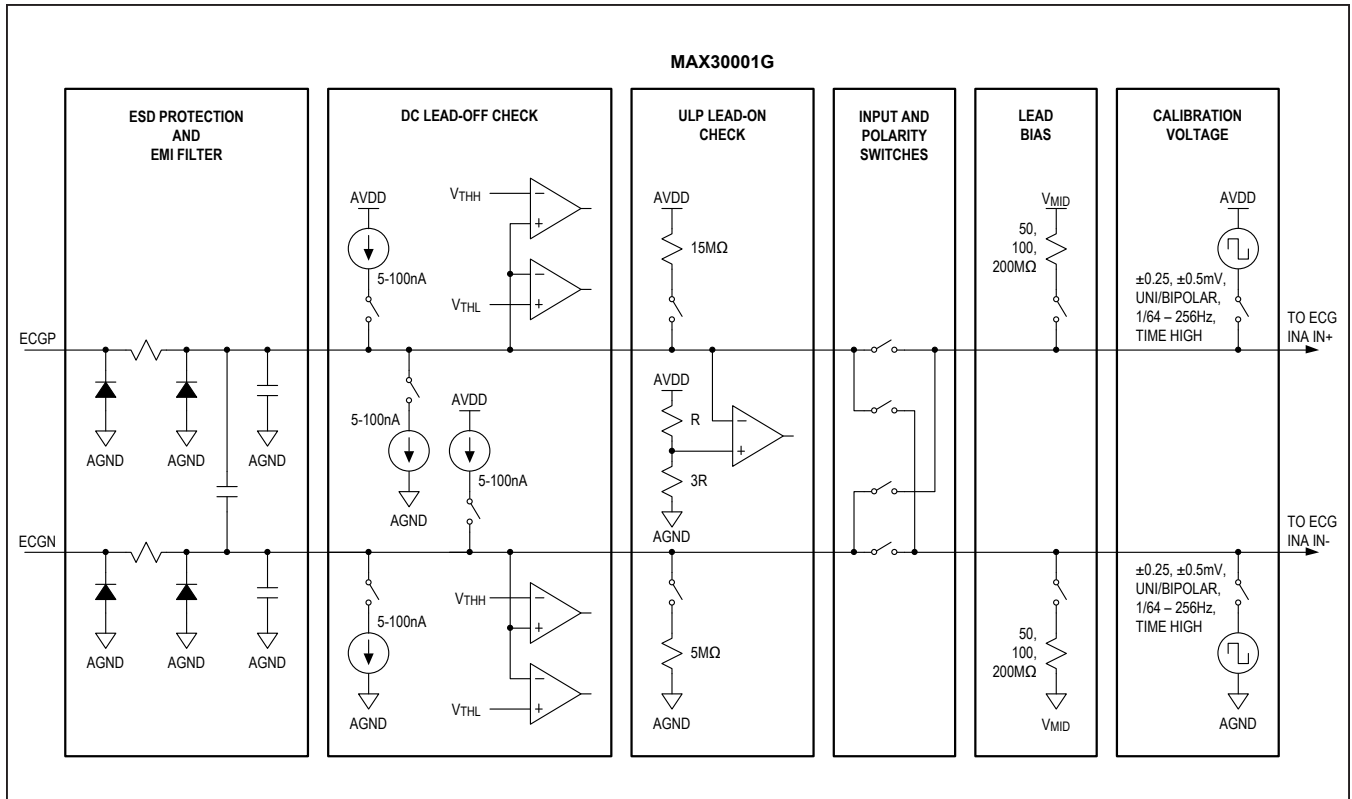

Figure 3. ECG Input MUX

### DC Leads-Off Detection and ULP Leads-On Detection

The input MUX leads-off detect circuitry consists of programmable sink/source DC current sources that allow for DC leads-off detection while the channel is powered up in normal operation and an ultra-low-power (ULP) leads-on detect while the channel is powered down.

The MAX30001G accomplishes DC leads-off detection by applying a DC current to pull the ECG input voltage up to above  $V_{MID} + V_{TH}$  or down to below  $V_{MID} - V_{TH}$ . The current sources have user selectable values of 0nA, 5nA, 10nA, 20nA, 50nA, and 100nA that allow coverage of dry and wet electrode impedance ranges. Supported thresholds are  $V_{MID} \pm 300\text{mV}$  (recommended),  $V_{MID} \pm 400\text{mV}$ ,  $V_{MID} \pm 450\text{mV}$ , and  $V_{MID} \pm 500\text{mV}$ . A threshold of 400mV, 450mV, and 500mV must only be used when  $V_{AVDD} \geq 1.45\text{V}$ , 1.55V, and 1.65V, respectively. A dynamic comparator protects against false flags generated by the input amplifier and input chopping. The comparator checks for a minimum continuous violation (or threshold exceeded) of 115ms to 140ms depending on the setting of FMSTR[1:0] before asserting any one of the LDOFF\_x interrupt flags (Figure 4). See registers CNFG\_GEN (0x10) and CNFG\_EMUX (0x14) for configuration settings and see Table 1 for recommended values given electrode type and supply voltage. The 0nA setting can also be used with the  $V_{MID} \pm 300\text{mV}$  threshold to monitor the input compliance of the INA when DC lead off detection is not needed.

The ULP lead on detect operates by pulling ECGN low with a pulldown resistance larger than  $5\text{M}\Omega$  and pulling ECGP high with a pullup resistance larger than  $15\text{M}\Omega$ . A low-power comparator determines if ECGP is pulled below a predefined threshold that occurs when both electrodes make contact with the body. When the impedance between ECGP and ECGN is less than  $20\text{M}\Omega$ , an interrupt LONINT is asserted, alerting the  $\mu\text{C}$  to a leads-on condition.

### Lead Bias

The MAX30001G limits the ECGP and ECGN DC input common mode range to  $V_{MID} \pm 150\text{mV}$  at  $V_{AVDD} = 1.1\text{V}$  or  $V_{MID} \pm 550\text{mV}$  (typ) at  $V_{AVDD} = 1.8\text{V}$ . This range can be maintained either through external or internal lead-biasing.

Internal DC lead-biasing consists of  $50\text{M}\Omega$ ,  $100\text{M}\Omega$ , or  $200\text{M}\Omega$  selectable resistors to  $V_{MID}$  that drive the electrodes within the input common mode requirements of the ECG channel and can drive the connected body to the proper common mode voltage level. See register CNFG\_GEN (0x10) to select a configuration.

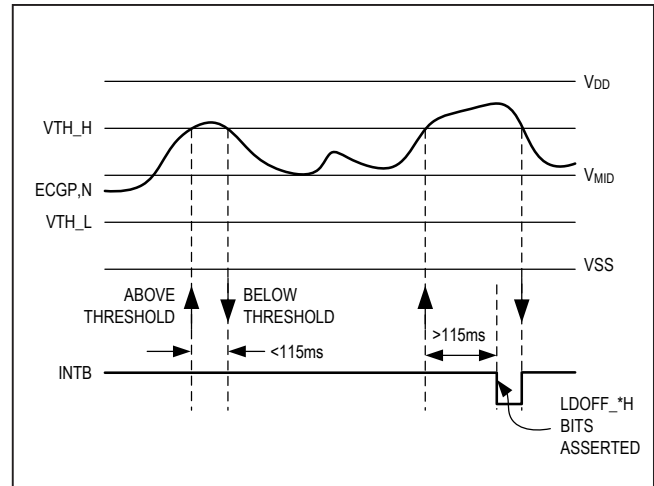

Figure 4. Lead Off Detect Behavior

The common-mode voltage,  $V_{CM}$ , can optionally be used as a body bias to drive the body to the common-mode voltage by connecting  $V_{CM}$  to a separate electrode on the body through a  $200\text{k}\Omega$  or higher resistor to limit current into the body according to IEC 60601-1:2005, 8.7.3. If this is utilized then the internal lead bias resistors to  $V_{MID}$  can be disabled.

### Isolation and Polarity Switches

The series switches in the MAX30001G isolate the ECGP and ECGN pins from the internal signal path, isolating it from the subject being monitored. The series switches are disabled by default. They must be enabled to record ECG. There are also polarity switches that will swap the inputs so that ECGP goes to the minus INA input and ECGN goes to the plus INA input.

### Calibration Voltage Sources

Calibration voltage sources are available to provide  $\pm 0.25\text{mV}$  ( $0.5\text{mV}_{P-P}$ ) or  $\pm 0.5\text{mV}$  ( $1.0\text{mV}_{P-P}$ ) inputs to the ECG channel with programmable frequency and duty cycle. The sources can be unipolar/bipolar relative to  $V_{MID}$ .

Figure 5 illustrates the possible calibration waveforms. Frequency selections are available in 4X increments from  $15.625\text{mHz}$  to  $256\text{Hz}$  with selected pulse widths varying from  $30.5\mu\text{s}$  to  $31.723\text{ms}$  and 50% duty cycle. Signals can be single-ended, differential, or common mode. This flexibility allows end-to-end channel-testing of the ECG signal path.

When applying calibration voltage sources with the device connected to a subject, the series input switches must be disconnected so as not to drive signals into the subject. See registers CNFG\_CAL (0x12) and CNFG\_EMUX (0x14) to select configuration.

**Table 1. Recommended Lead Bias, Current Source Values, and Thresholds for Electrode Impedance**

I <sub>DC</sub> V <sub>TH</sub>	ELECTRODE IMPEDANCE							
	<100kΩ	100kΩ – 200kΩ	200kΩ – 400kΩ	400kΩ – 1MΩ	1MΩ – 2MΩ	2MΩ – 4MΩ	4MΩ – 10MΩ	10MΩ – 20MΩ
I <sub>DC</sub> = 10nA	All settings of R <sub>b</sub> V <sub>TH</sub> = V <sub>MID</sub> ± 300mV, ± 400mV							
I <sub>DC</sub> = 20nA	All settings of R <sub>b</sub> All settings of V <sub>TH</sub>							All settings of R <sub>b</sub> V <sub>TH</sub> =V <sub>MID</sub> ± 400mV, ±450mV, ±500mV
I <sub>DC</sub> = 50nA	All settings of R <sub>b</sub> All settings of V <sub>TH</sub>					All settings of R <sub>b</sub> V <sub>TH</sub> =V <sub>MID</sub> ±450mV, ±500mV		
I <sub>DC</sub> = 100nA	All settings of R <sub>b</sub> All settings of V <sub>TH</sub>				All settings of R <sub>b</sub> V <sub>TH</sub> =V <sub>MID</sub> ± 400mV, ±450mV, ±500mV			

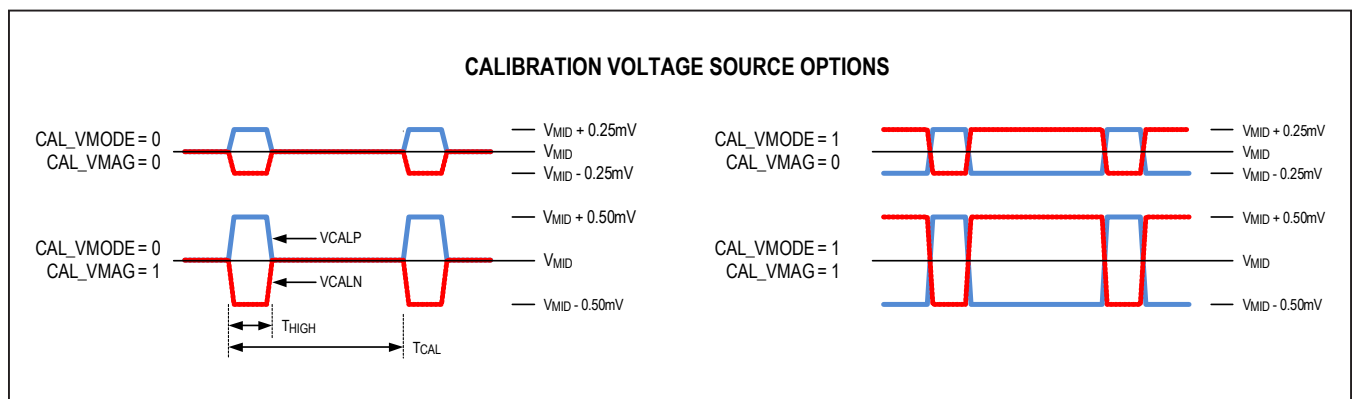

Figure 5. Calibration Voltage Source Options



### Gain Settings, Input Range, and Filtering

The device's ECG channel contains an input instrumentation amplifier that provides low-noise, fixed-gain amplification (gain of 20) of the differential signal, rejects differential DC voltage due to electrode polarization, rejects common-mode interference primarily due to AC mains interference, and provides high input impedance to guarantee high CMRR even in the presence of severe electrode impedance mismatch (see [Figure 2](#)). The differential DC rejection corner frequency is set by an external capacitor ( $C_{HPF}$ ) placed between pins CAPP and CAPN, refer to [Table 2](#) for appropriate value selection. There are three recommended options for the cutoff frequency: 5Hz, 0.5Hz, and 0.05Hz. Setting the cutoff frequency to 5Hz provides the most motion artifact rejection at the expense of ECG waveform quality, making it best suited for heart rate monitoring. For ambulatory applications requiring more robust ECG waveforms with moderate motion artifact rejection, 0.5Hz is recommended. Select 0.05Hz for patient monitoring applications in which ECG waveform quality is the primary concern and poor rejection of motion artifacts can be tolerated. The high-pass corner frequency is calculated by the following equation:

$$1/(2\pi \times R_{HPF} \times C_{HPF})$$

$R_{HPF}$  is specified in the Electrical Characteristics table. Following the instrumentation amplifier is a 2-pole active anti-aliasing filter with a 600Hz -3dB frequency that provides 57dB of attenuation at half the modulator sampling rate (approximately 16kHz) and a PGA with programmable gains of 1, 2, 4, and 8V/V for an overall gain of 20, 40, 80, and 160V/V. The instrumentation amplifier and PGA are chopped to minimize offset and 1/f noise. Gain settings are configured via the CNFG\_ECG (0x15) register. The usable common-mode range is  $V_{MID} \pm 150\text{mV}$  at  $V_{AVDD} = 1.1\text{V}$  or  $V_{MID} \pm 550\text{mV}$  (typ) at  $V_{AVDD} = 1.8\text{V}$ . Internal lead biasing can be used to meet this requirement. The usable DC differential range is  $\pm 300\text{mV}$  at  $V_{AVDD} = 1.1\text{V}$  or  $\pm 650\text{mV}$  (typ) at  $V_{AVDD} = 1.8\text{V}$  to allow for electrode polarization voltages on each electrode. The input AC differential range is  $\pm 32.5\text{mV}$  or  $65\text{mV}_{p-p}$ .

### Converting ECG Samples to Voltage

ECG samples are recorded in 18-bit, left justified two's complement format. After converting to signed magnitude format, the ECG input voltage is calculated by the following equation:

$$V_{ECG} (\text{mV}) = \text{ADC} \times V_{REF} / (2^{17} \times \text{ECG\_GAIN})$$

ADC is the ADC counts in signed magnitude format,  $V_{REF}$  is 1000mV (typ) (refer to the [Electrical Characteristics](#) section), and ECG\_GAIN is 20V/V, 40V/V, 80V/V, or 160V/V, set in CNFG\_ECG (0x15).

### Fast Recovery Mode

The input instrumentation amplifier has the ability to rapidly recover from an excessive overdrive event such as a defibrillation pulse, high-voltage external pacing, and electro-surgery interference. There are two modes of recovery that can be used: automatic or manual recovery. The mode is programmed by the FAST[1:0] bits in the MNGR\_DYN (0x05) register.

**Table 2. ECG Analog HPF Corner Frequency Selection**

$C_{HPF}$ ( $\mu\text{F}$ )	HPF CORNER FREQUENCY (Hz)
0.1	$\leq 5$
1.0	$\leq 0.5$
10	$\leq 0.05$

**Table 3. Fast Recovery Mode Recovery Time vs. Number of Samples**

SAMPLE RATE (sps)	NUMBER OF SAMPLES	RECOVERY TIME (APPROXIMATE) (ms)
512	255	498
256	127	496
128	63	492
500	249	498
250	124	496
125	64	512
200	99	495
199.8	99	495.5

Automatic mode engages once the saturation counter exceeds approximately 125ms ( $t_{SAT}$ ). The counter is activated the first time the ADC output exceeds the symmetrical threshold defined by the FAST\_TH[5:0] bits in the MNGR\_DYN (0x05) register and accumulates the time that the ADC output exceeds either the positive or negative threshold. If the saturation counter exceeds 125ms, it triggers the fast settling mode (if enabled) and resets. The saturation counter can also be reset prior to triggering the fast settling mode if the ADC output falls below the threshold continuously for 125ms ( $t_{BLW}$ ). This feature is designed to avoid false triggers due to the QRS complex. Once triggered, fast settling mode is engaged for 500ms,

(Table 3). ECG samples are tagged if they were taken while fast settling mode was asserted (Figure 6).

In manual mode, a user algorithm running on the host microcontroller or an external stimulus input will generate the trigger to enter fast recovery mode. The host microcontroller then enables the manual fast recovery mode in the MNGR\_DYN (0x05) register. The manual fast recovery mode can be of a much shorter duration than the automatic mode and allows for more rapid recovery. One such example is recovery from external high-voltage pacing signals in a few milliseconds to allow the observation of a subsequent p-wave.

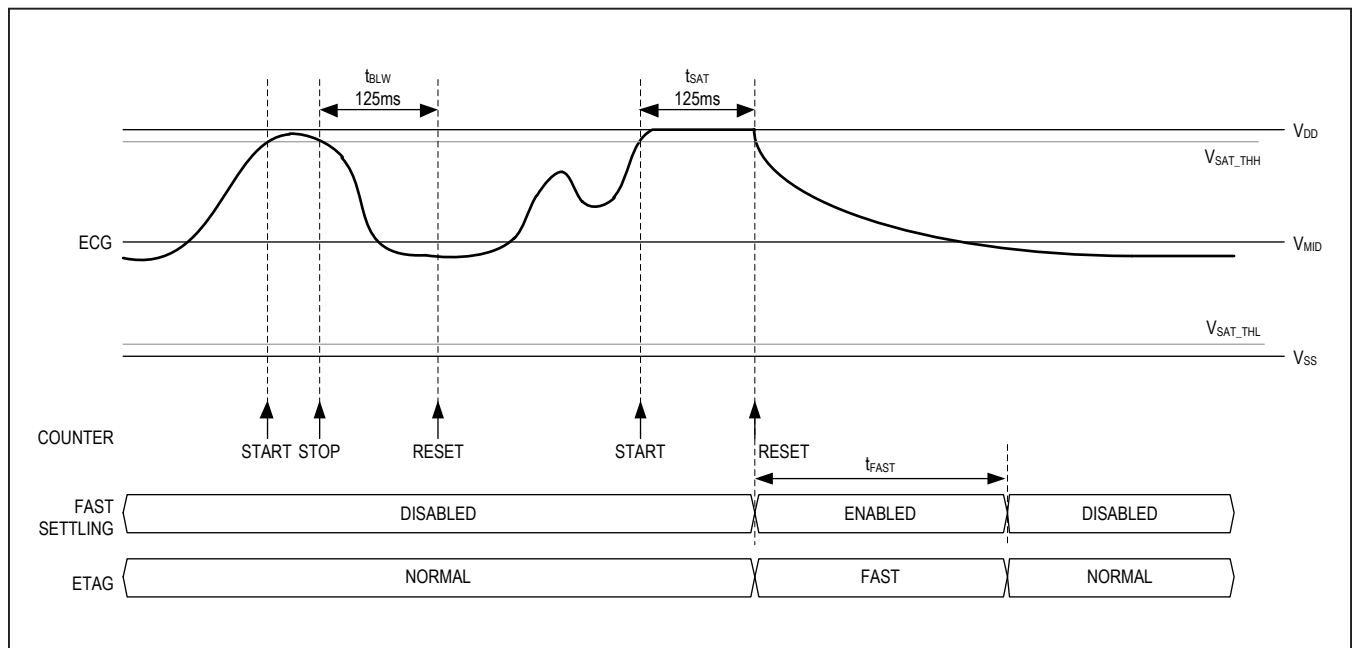

Figure 6. Automatic Fast Settling Behavior

**Decimation Filter**

The decimation filter consists of an FIR decimation filter to the data rate followed by a programmable IIR and FIR filter to implement HPF and LPF selections.

The high-pass filter options include a 1st-order IIR Butterworth filter with a 0.4Hz corner frequency along with a pass through setting for DC coupling. Low-pass filter options include a 12-tap linear phase (constant group

delay) approximately 40Hz, 100Hz, or 150Hz corner frequencies, depending on the sampling rate. See register CNFG\_ECG (0x15) to configure the filters. [Table 4](#) illustrates the ECG latency in samples and time for each ADC data rate.

**Noise Measurements**

[Table 5](#) shows the noise performance of the ECG channel of MAX30001G referred to the ECG inputs.

**Table 4. ECG Latency in Samples and Time as a Function of ECG Data Rate and Decimation**

ECG CHANNEL SETTINGS			LATENCY			
INPUT SAMPLE RATE (Hz)	OUTPUT DATA RATE (sps)	DECIMATION RATIO	WITHOUT LPF (INPUT SAMPLES)	WITH LPF (INPUT SAMPLES)	WITHOUT LPF (ms)	WITH LPF (ms)
32,768	512	64	650	1,034	19.836	31.555
32,000	500	64	650	1,034	20.313	32.313
32,768	256	128	2,922	3,690	89.172	112.610
32,000	250	128	2,922	3,690	91.313	115.313
32,000	200	160	1,242	2,202	38.813	68.813
31,968	199.8	160	1,242	2,202	38.851	68.881
32,768	128	256	3,370	4,906	102.844	149.719
32,000	125	256	3,370	4,906	105.313	153.313

**Table 5. ECG Channel Noise Performance**

GAIN	BANDWIDTH	NOISE		SNR	ENOB
		$\mu\text{V}_{\text{RMS}}$	$\mu\text{V}_{\text{P-P}}$		
V/V	Hz			dB	Bits
20	40	0.46	3.04	97.7	15.9
	100	0.64	4.20	94.9	15.5
	150	0.77	4.60	93.2	15.2
40	40	0.40	2.64	92.9	15.1
	100	0.54	3.56	90.3	14.7
	150	0.66	4.34	88.6	14.4
80	40	0.35	2.31	88.0	14.3
	100	0.50	3.33	84.9	13.8
	150	0.62	4.09	83.1	13.5
160	40	0.34	2.22	82.4	13.4
	100	0.49	3.24	79.1	12.8
	150	0.61	4.01	77.2	12.5

**R-to-R Detection**

The MAX30001G contains built-in hardware to detect R-R intervals using an adaptation of the Pan-Tompkins QRS detection algorithm\*. The timing resolution of the R-R interval is approximately 8ms and depends on the setting of FMSTR [1:0] in CNFG\_GEN (0x10) register. See [Table 26](#) for the timing resolution of each setting.

When an R event is identified, the RRINT status bit is asserted and the RTOR\_REG (0x25) register is updated with the count seen since the last R event. [Figure 7](#) illustrates the R-R interval on a QRS complex. Refer to registers CNFG\_RTOR1 (0x1D) and CNFG\_RTOR2 (0x1E) for selection details.

The latency of the R-to-R value written to the RTOR Interval Memory Register is the sum of the R-to-R decimation delay and the R-to-R detection delay blocks. The R-to-R decimation factor is fixed at 256 and the decimation delay ( $t_{R2R\_DEC}$ ) is always 3,370 FMSTR clocks, as shown in [Table 6](#).

The detection circuit consists of several digital filters and signal processing delays. These depend on the WNDW[3:0] bits in the CNFG\_RTOR (0x1D) register. The detection delay ( $t_{R2R\_DET}$ ) is described by the following equation:

$$t_{R2R\_DET} = 5,376 + 256 \times \text{WNDW in FMSTR clocks}$$

where WNDW is an integer from 0 to 15

and the total latency ( $t_{R2R\_DEL}$ ) is the sum of the two delays and summarized in the equation below:

$$t_{R2R\_DEL} = t_{R2R\_DEC} + t_{R2R\_DET} = 3,370 + 5,376 + 256 \times \text{WNDW in FMSTR clocks}$$

where WNDW is an integer from 0 to 15.

The total R-to-R latency minus the ECG latency is the delay of the R-to-R value relative to the ECG data and can be used to place the first R-to-R value on the ECG data plot. The succeeding values in the R-to-R Interval Memory Register can be used as is to locate subsequent R-to-R values on the ECG data plot relative to the initial placement.

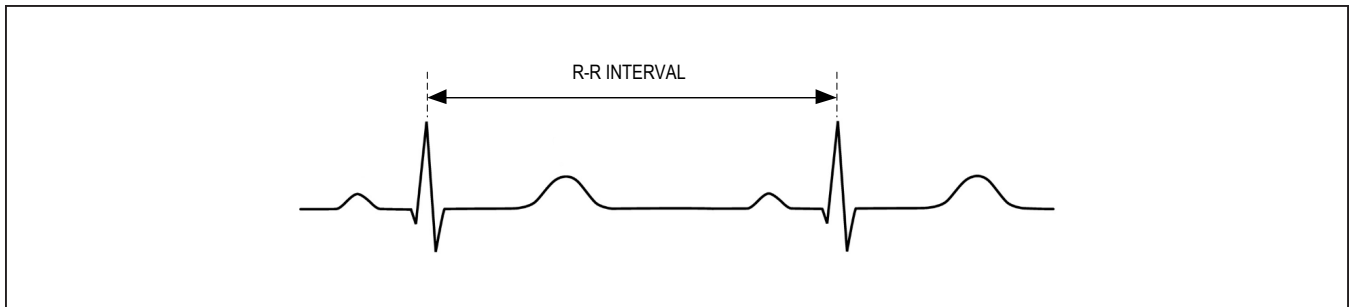

Figure 7. R-to-R Interval Illustration

**Table 6. R-to-R Decimation Delay vs. Register Settings**

FMSTR [1:0]	FMSTR FREQ	FMSTR FREQ (Hz)	DECIMATION	RTOR TIME RESOLUTION (ms)	DELAY IN R-TO-R DECIMATION	
					FMSTR CLKs	(ms)
00	FCLK	32,768	256	7.8125	3370	102.844
01	FCLK x 625/640	32,000	256	8.0	3370	105.313
10	FCLK x 625/640	32,000	256	8.0	3370	105.313
11	FCLK x 640/656	31,968.78	256	8.0078	3370	105.415

\*J. Pan and W.J. Tompkins, "A Real-Time QRS Detection Algorithm," IEEE Trans. Biomed. Eng., vol. 32, pp. 230-236

### BioZ Channel

Figure 8 illustrates the BioZ channel block diagram, excluding the ADC. The channel comprises an input MUX, an instrumentation amplifier, a mixer, an anti-alias filter, and a programmable gain amplifier. The MUX includes several features such as ESD protection, EMI filtering, lead biasing, leads off checking, and ultra-low power leads-on checking. The output of this analog channel drives a 20-bit Sigma-Delta ADC.

### Input MUX

The BioZ input MUX shown in Figure 9 contains integrated ESD and EMI protection, DC leads off detect current sources and comparators, lead-on detect, series isolation switches, lead biasing, a programmable calibration voltage source to enable channel built in self-test and a built in programmable resistor load.

### EMI Filtering and ESD Protection

EMI filtering of the BIP and BIN inputs consists of a single pole, low pass, differential, and common mode filter with the pole located at approximately 26MHz. The BIP and BIN inputs also have input clamps that protect the inputs from ESD events.

- $\pm 8\text{kV}$  using the Contact Discharge method specified in IEC61000-4-2 ESD
- $\pm 15\text{kV}$  using the Air Gap Discharge method specified in IEC61000-4-2 ESD
- For IEC61000-4-2 ESD protection, use  $1\text{k}\Omega$  series resistors on BIP and BIN that is rated to withstand  $\pm 8\text{kV}$  surge voltages

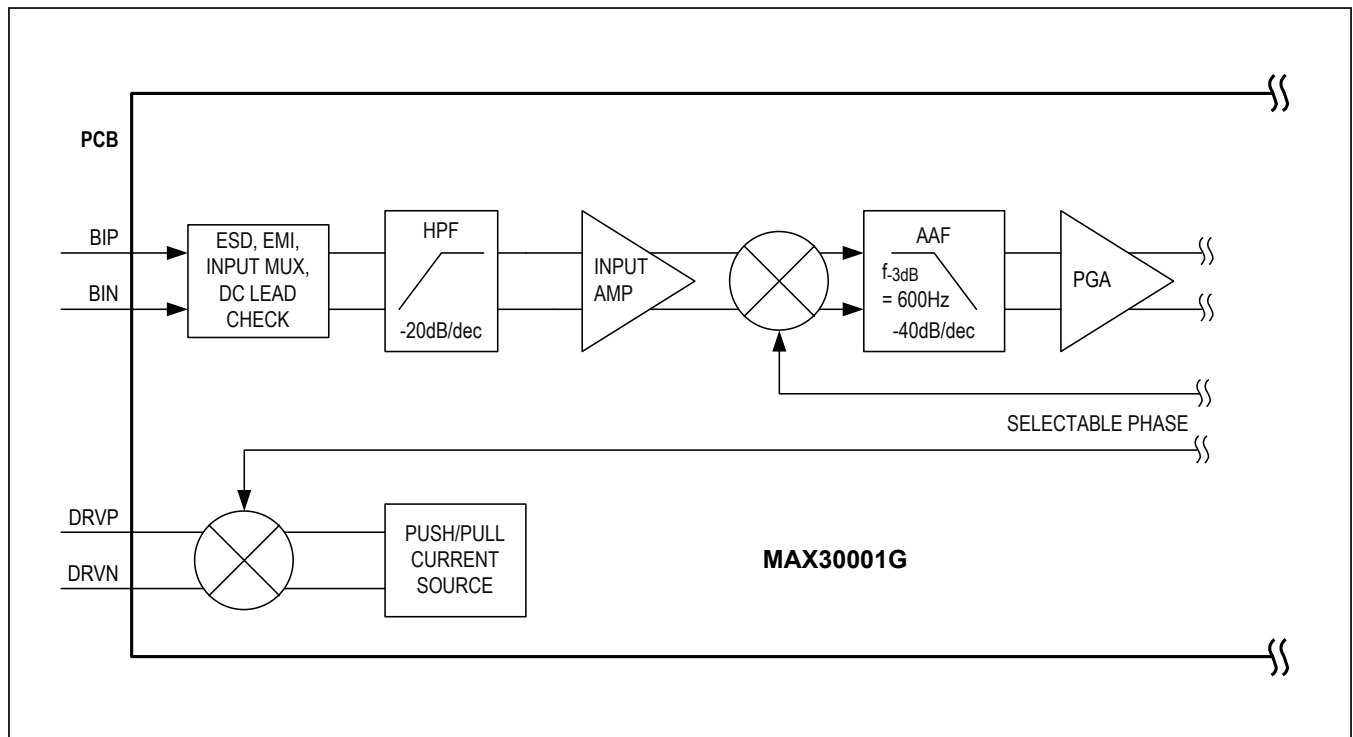

Figure 8. BioZ Channel Input Amplifier, Mixer, and PGA Excluding the ADC and Current Drive Output

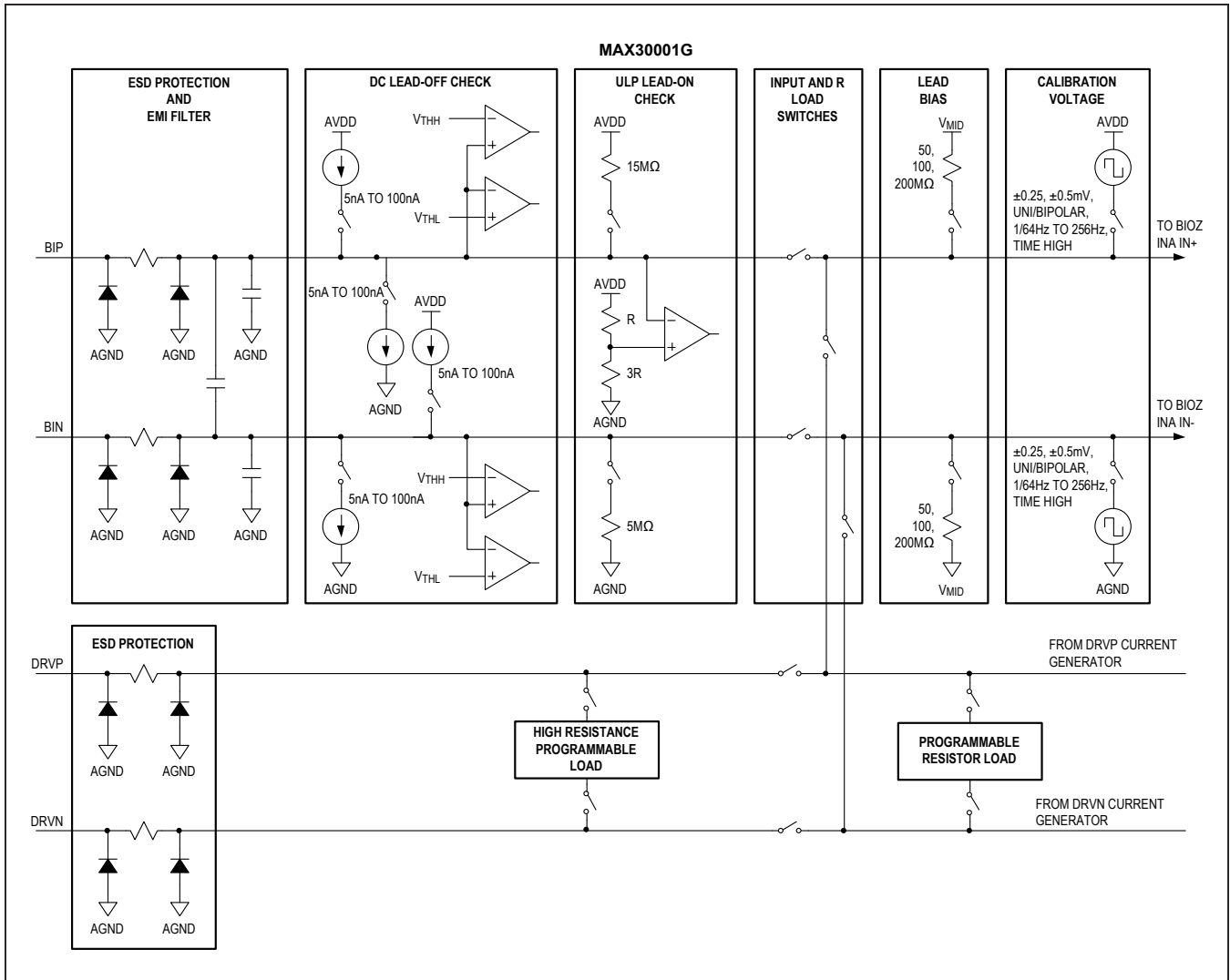

Figure 9. BioZ Input MUX

**Leads-Off Detection and ULP Leads-On Detection**

MAX30001G provides the capability of detecting lead off scenarios that involve two electrode and four electrode configurations through the use of digital threshold and analog threshold comparisons. There are three methods to detect lead-off for the BioZ channel. There is a compliance monitor for the current generator on the DRVP and DRVN pins detecting when the voltage on the pins is outside its operating range. The BIOZ\_CGMON bit in the CNFG\_BIOZ (0x18) register enables this function and the BCGMON, BCGMP, and BCGMN bits in the STATUS (0x01) register indicate if the DRVP and DRVN pins are out of compliance. There is a DC lead-off circuit on the BIP and BIN pins (same as on the ECGP and ECGN pins, see ECG description) that sinks or sources a programmable DC current and window comparators with a programmable threshold to detect the condition. There is a digital AC lead off detection monitoring the output of the BioZ ADC with programmable under and overvoltage levels performing a digital comparison. The EN\_BLOFF bit in the CNFG\_GEN (0x10) register enables this function and the BLOFF\_HI\_IT[7:0] and BLOFF\_LO\_IT[7:0] bits in the MNGR\_DYN (0x05) register sets the digital threshold for detection. Refer to [Table 7](#) for lead off conditions and register settings to allow detection.

The 0nA setting can also be used with the  $V_{MID} \pm 300\text{mV}$  threshold to monitor the input compliance of the INA when DC lead off detection is not needed.

The ULP lead-on detect operates by pulling BIN low with a pulldown resistance larger than  $5\text{M}\Omega$  and pulling BIP high with a pullup resistance larger than  $15\text{M}\Omega$ . A low-power comparator determines if BIP is pulled below a predefined threshold that occurs when both electrodes make contact with the body. When the impedance between BIP and BIN is less than  $20\text{M}\Omega$ , an interrupt LONINT is asserted, alerting the  $\mu\text{C}$  to a leads-on condition.

**Lead Bias**

The MAX30001G limits the BIP and BIN DC input common mode range to  $V_{MID} \pm 150\text{mV}$  at  $V_{AVDD} = 1.1\text{V}$  or  $V_{MID} \pm 550\text{mV}$  (typ) at  $V_{AVDD} = 1.8\text{V}$ . This range can be maintained either through external/internal lead-biasing.

Internal DC lead-biasing consists of  $50\text{M}\Omega$ ,  $100\text{M}\Omega$ , or  $200\text{M}\Omega$  selectable resistors to  $V_{MID}$  that drive the electrodes within the input common mode requirements of the ECG channel and can drive the connected body to the proper common mode voltage level. See the EN\_RBIAS[1:0], RBIASV[1:0], RBIASP, and RBIASN bits in the CNFG\_GEN (0x10) register to select a configuration.

**Table 7. BioZ Lead Off Detection Configurations**

CONFIGURATION	CONDITION	DRVP/N	BIP/N	MEASURED SIGNAL	REGISTER SETTING TO DETECT
Two-Electrode (Shared DRV/BI)	1 Electrode Off	Rail to Rail	Rail to Rail	Rail to Rail (Saturated Inputs)	CNFG_GEN (0x10), EN_BLOFF[1:0] = 10 or 11 MNGR_DYN (0x05), BLOFF_HI_IT[7:0]
Four-Electrode (Force/Sense)	1 DRV Electrode Off, Large Body Coupling	Rail to Rail	Normal	$\frac{1}{2}$ Signal	CNFG_BIOZ (0x18), BIOZ_CGMON=1
	1 DRV Electrode Off, Small Body Coupling	Rail to Rail	Rail to Rail	Rail to Rail (Saturated Inputs)	CNFG_GEN (0x10), EN_BLOFF[1:0] = 10 or 11 MNGR_DYN (0x05), BLOFF_HI_IT[7:0]
	1 BI (sense) Electrode Off	Normal	Floating	$\frac{1}{2}$ Signal	CNFG_GEN (0x10), EN_DCLOFF=10
	Both BIP/N (sense) Electrodes Off	Normal	Floating	No Signal	CNFG_GEN (0x10), EN_BLOFF[1:0] = 01 or 11 MNGR_DYN (0x05), BLOFF_LO_IT[7:0]
	1 DRV and 1 BI Electrode Off	Rail to Rail	Wide Swing, Dependent on Body Coupling	Rail to Rail	CNFG_GEN (0x10), EN_BLOFF[1:0] = 10 or 11 MNGR_DYN (0x05), BLOFF_HI_IT[7:0]

The common-mode voltage,  $V_{CM}$ , can optionally be used as a body bias to drive the body to the common-mode voltage by connecting  $V_{CM}$  to a separate electrode on the body through a 200k $\Omega$  or higher resistor to limit current into the body according to IEC 60601-1:2005, 8.7.3. If this is utilized then the internal lead bias resistors to  $V_{MID}$  can be disabled. If ECGP/ECGN pins are shared with the BIP/BIN pins then it is only necessary to enable lead bias on ECG or BioZ.

**Calibration Voltage Sources**

Calibration voltage sources are available to provide  $\pm 0.25mV$  (0.5mV<sub>P-P</sub>) or  $\pm 0.5mV$  (1.0mV<sub>P-P</sub>) inputs to the

BioZ/Pace channel with programmable frequency and duty cycle. The sources can be unipolar/bipolar relative to  $V_{MID}$ .

Figure 10 illustrates the possible calibration waveforms. Frequency selections are available in 4X increments from 15.625mHz to 256Hz with selected pulse widths varying from 30.5 $\mu s$  to 31.723ms and 50% duty cycle. Signals can be single-ended, differential, or common mode.

When applying calibration voltage sources with the device connected to a subject, the series input switches must be disconnected so as not to drive signals into the subject. See registers CNFG\_CAL (0x12) and CNFG\_BMUX (0x14) to select configuration.

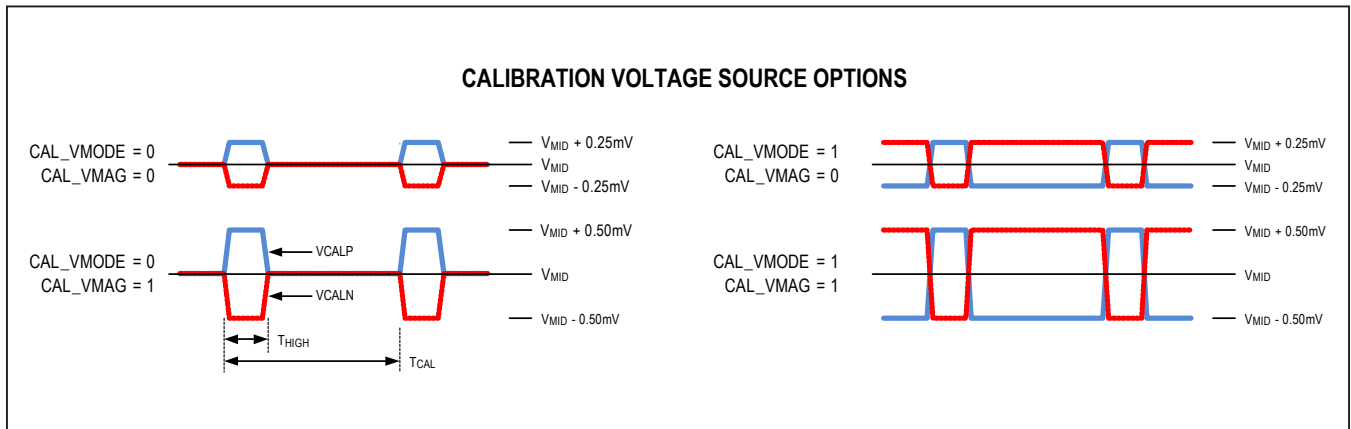

Figure 10. Calibration Voltage Source Options

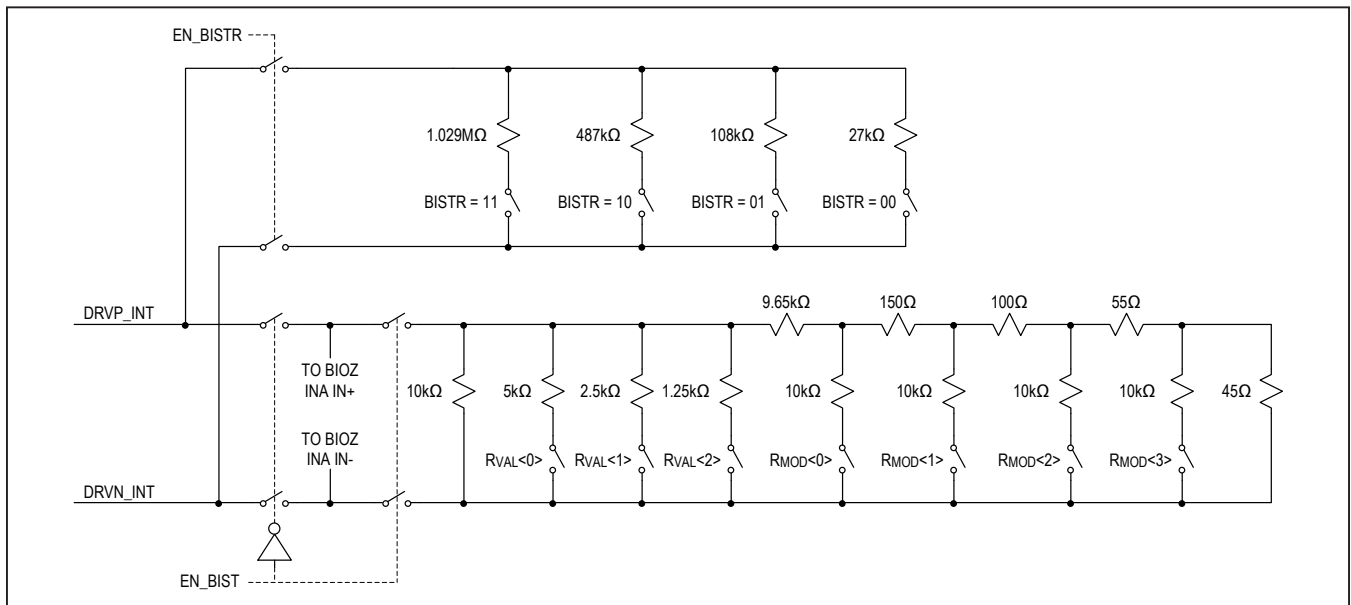

Figure 11. Programmable Resistive Load Topology



**Programmable Resistive Load**

The programmable resistive load on the DRVP/DRVN pins allows a built in self-test of the current generator (CG) and the entire BioZ channel. Refer to [Figure 11](#) for implementation details.

Nominal resistance can be varied between 625Ω and 1.029MΩ. For nominal values between 625Ω and 5kΩ, the resistance can be modulated using  $R_{MOD}$ . The modulation resistance is used to switch the load resistance between  $R_{NOM}$  and  $(R_{NOM} - R_{MOD})$  at the selected modulation rate. The modulation resistance is dependent on the nominal resistance value with resolution of 50.4mΩ to 2.96Ω at the largest nominal resistance (5kΩ) and 15.3mΩ to 46.3mΩ with the smallest nominal resistance

(625Ω). Refer to [Table 8a](#) for a complete listing of nominal and modulated resistor values. Modulation rate can be programmed between 625mHz to 4Hz.

See registers CNFG\_CAL (0x12), CNFG\_BIOZ\_LC (0x1A), and CNFG\_BMUX (0x17) to select configuration for modulation rate and resistor value.

**Current Generator**

The current generator provides square-wave modulating differential current that is AC injected into the body via pins DRVP and DRVN with the bio-impedance sensed differentially through pins BIP and BIN. Two and four electrode configurations are supported for typical wet and dry electrode impedances.

**Table 8a. Programmable Resistive Load Values**

$R_{NOM}$ (Ω)	$R_{MOD}$ (mΩ)	$R_{VAL}$			$R_{MOD}$			
		<2>	<1>	<0>	<3>	<2>	<1>	<0>
5000.000	—	0	0	0	0	0	0	0
	2960.7	0	0	0	0	0	0	1
	980.6	0	0	0	0	0	1	0
	247.5	0	0	0	0	1	0	0
2500.000	—	0	0	1	0	0	0	0
	740.4	0	0	1	0	0	0	1
	245.2	0	0	1	0	0	1	0
	61.9	0	0	1	0	1	0	0
1666.667	—	0	1	0	0	0	0	0
	329.1	0	1	0	0	0	0	1
	109.0	0	1	0	0	0	1	0
	27.5	0	1	0	0	1	0	0
1250.000	—	0	1	1	0	0	0	0
	185.1	0	1	1	0	0	0	1
	61.3	0	1	1	0	0	1	0
1000.000	—	1	0	0	0	0	0	0
	118.5	1	0	0	0	0	0	1
	39.2	1	0	0	0	0	1	0
833.333	—	1	0	1	0	0	0	0
	82.3	1	0	1	0	0	0	1
	27.2	1	0	1	0	0	1	0
714.286	—	1	1	0	0	0	0	0
	60.5	1	1	0	0	0	0	1
	20.0	1	1	0	0	0	1	0
625.000	—	1	1	1	0	0	0	0
	46.3	1	1	1	0	0	0	1
	15.3	1	1	1	0	0	1	0

**Table 8b. High Resistance Programmable Load Values**

R <sub>NOM</sub> (kΩ)	BISTR	
	<1>	<0>
27	0	0
108	0	1
487	1	0
1029	1	1

Current amplitudes between 55nA<sub>PK</sub> to 96μA<sub>PK</sub> are selectable with current injection frequencies between 125Hz and 131.072kHz in power of two increments. See registers CNFG\_BIOZ (0x18) and CNFG\_BIOZ\_LC (0x1A) for configuration selections.

Current amplitude should be chosen so as not exceed 90mV<sub>PK</sub> at the BIP and BIN pins based on the network impedance at the current injection frequency. A 47nF or higher DC blocking capacitor is required between both DRVP and DRVN and their respective electrodes. For operation down to 125Hz, increase the capacitance to 220nF.

The current generator also includes a phase offset adjustment, which delays the drive current modulator with respect to the input mixer. The phase can be adjusted in 11.25° increments from 0° to 168.75° for injection frequencies up to f<sub>MSTR</sub>. For injection frequencies of 2 x f<sub>MSTR</sub> and 4 x f<sub>MSTR</sub>, the phase resolution is reduced to 22.5° and 45° respectively. See CNFG\_BIOZ (0x18) for details.

**Converting BioZ Samples to Ωs**

BioZ samples are recorded in 20-bit, left justified two's compliment format. After converting to signed magnitude format, BioZ is calculated by the following equation:

$$\text{BioZ } (\Omega) = \text{ADC} \times V_{\text{REF}} / (2^{19} \times \text{BIOZ\_CGMAG} \times \text{BIOZ\_GAIN})$$

ADC is the ADC counts in signed magnitude format, V<sub>REF</sub> is 1V (typ) (refer to the [Electrical Characteristics](#) section), BIOZ\_CGMAG is 50 x 10<sup>-9</sup> to 96 x 10<sup>-6</sup> A, set by CNFG\_BIOZ and CNFG\_BIOZ\_LC and BIOZ\_GAIN is 10V/V, 20V/V, 40V/V, or 80V/V. BIOZ\_GAIN are set in CNFG\_BIOZ (0x18).

**Current Selection and Resolution Calculation Example 1 (Two Terminal with Common Protection)**

Selection of the appropriate current is accomplished by first calculating the resistive component of the network impedance at the injection frequency. Worst case electrode impedances should be used.

Given [Figure 12](#) and a current injection frequency of 80kHz, the BioZ measurement range can be estimated with the resistive component of the equivalent load impedance at 80kHz:

$$R_{\text{BODY}} + 2R_{P1} + 2R_{P2} + 2R_S + \text{Re}\left\{\frac{2R_E}{1 + j\omega R_E C_E}\right\} = 2.7\text{k}\Omega$$

where R<sub>BODY</sub> = 100Ω, R<sub>P1</sub> = 1kΩ, R<sub>P2</sub> = 200Ω, R<sub>S</sub> = 100Ω, R<sub>E</sub> = 1MΩ, C<sub>E</sub> = 5nF. The maximum current injection is the maximum AC input differential range (90mV<sub>PK</sub>) divided by the network impedance (2.7kΩ) or 33.3μA<sub>PK</sub>. The closest selectable lower value is 32μA<sub>PK</sub>.

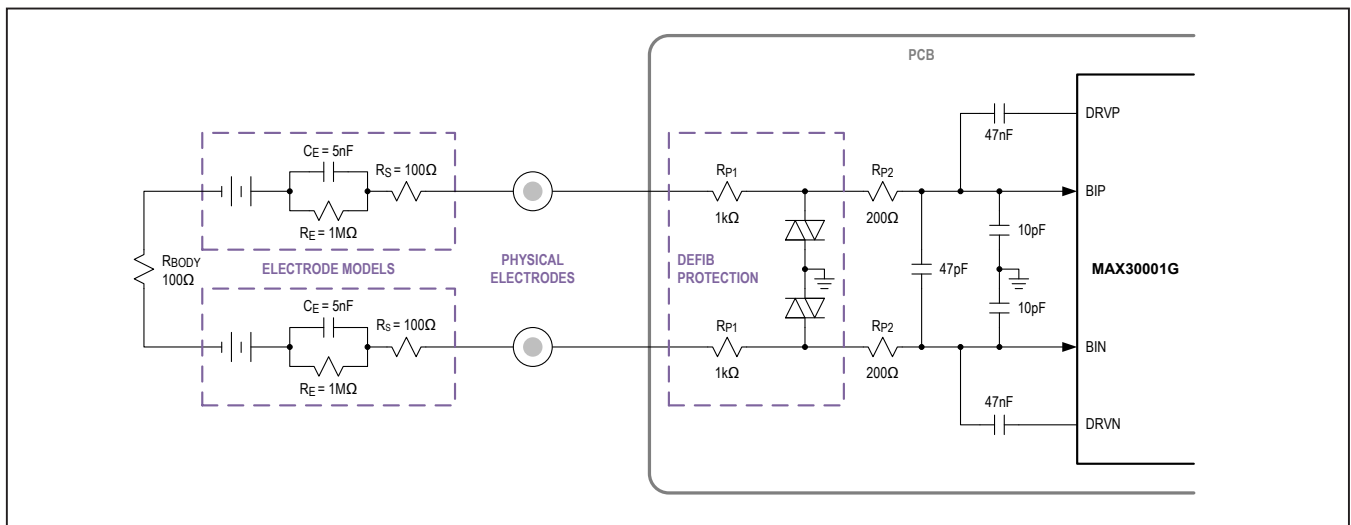

Figure 12. Example Configuration – Two Terminal with Common Protection

Given the current injection value and the channel bandwidth (refer to register CNFG\_BIOZ (0x18) for digital LPF selection) the resolvable impedance can be calculated by dividing the appropriate input referred noise by the current injection value. For example, with a bandwidth of 4Hz, the input referred noise with a gain of 20V/V is 0.16µV<sub>RMS</sub> or 1.1µV<sub>P-P</sub>. The resolvable impedance is therefore 1.1µV<sub>P-P</sub> / 32µA<sub>PK</sub> = 69mΩ<sub>P-P</sub> or 5mΩ<sub>RMS</sub>.

**Current Selection and Resolution Calculation Example 2 (Four Terminal)**

Selection of the appropriate current is accomplished by first calculating the resistive component of the network impedance at the injection frequency. Worst case electrode impedances should be used.

Given Figure 13 and a current injection frequency of 80kHz, the BioZ measurement range can be estimated with the resistive component of the equivalent load impedance at 80kHz:

$$R_{BODY} + 2R_{DP1} + 2R_{DP2} + 2R_S + Re \left\{ \frac{2R_E}{1 + j\omega R_E C_E} \right\} = 2.7k\Omega$$

where R<sub>BODY</sub> = 100Ω, R<sub>DP1</sub> = 1kΩ, R<sub>DP2</sub> = 200Ω, R<sub>S</sub> = 100Ω, R<sub>E</sub> = 1MΩ, C<sub>E</sub> = 5nF. The maximum current injection is the maximum DRVP/N Compliance Voltage

(V<sub>DD</sub>-0.5V = 0.6V for V<sub>DD</sub> = 1.1V) divided by the network impedance (2.7kΩ) or 222.2µA<sub>PK</sub>. The closest selectable lower value is 96µA<sub>PK</sub>.

Given the current injection value and the channel bandwidth (refer to register CNFG\_BIOZ (0x18) for digital LPF selection) the resolvable impedance can be calculated by dividing the appropriate input referred noise by the current injection value. For example, with a bandwidth of 4Hz, the input referred noise with a gain of 40V/V is 0.12µV<sub>RMS</sub> or 0.78µV<sub>P-P</sub>. The resolvable impedance is therefore 0.78µV<sub>P-P</sub>/96µA<sub>PK</sub> = 8mΩ<sub>P-P</sub> or 1.2mΩ<sub>RMS</sub>.

**Decimation Filter**

The decimation filter consists of an FIR decimation filter to the data rate followed by a programmable IIR and FIR filter to implement HPF and LPF selections.

The high-pass filter options include a fourth-order IIR Butterworth filter with a 0.05Hz or 0.5Hz corner frequency along with a pass through setting for DC coupling. Lowpass filter options include a 12-tap linear phase (constant group delay) FIR filter with 4Hz, 8Hz, or 16Hz corner frequencies. See register CNFG\_BIOZ (0x18) to configure the filters. Table 9 illustrates the BioZ latency in samples and time for each ADC data rate.

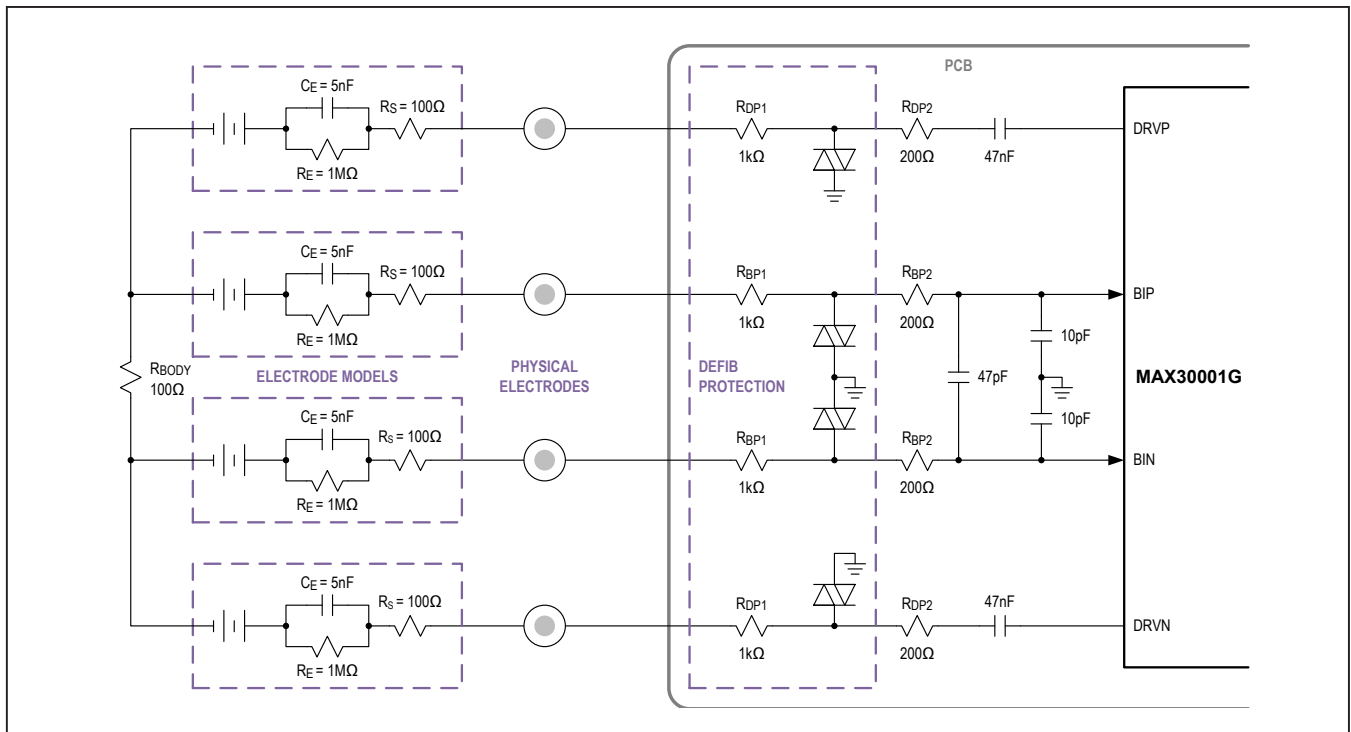

Figure 13. Example Configuration—Four Terminal

**Noise Measurements**

Table 10 shows the noise performance of the BioZ channel of MAX30001G referred to the BioZ inputs.

**Reference and Common Mode Buffer**

The MAX30001G features internally generated reference voltages. The bandgap output ( $V_{BG}$ ) pin requires an external  $1.0\mu\text{F}$  capacitor to AGND and the reference output ( $V_{REF}$ ) pin requires a  $10\mu\text{F}$  external capacitor to AGND for compensation and noise filtering.

A common-mode buffer is provided to buffer 650mV which is used to drive common mode voltages for internal blocks. Use a  $10\mu\text{F}$  external capacitor between  $V_{CM}$  to AGND to provide compensation and noise filtering. The common-mode voltage,  $V_{CM}$ , can optionally be used as a body bias to drive the body to the common-mode voltage by connecting  $V_{CM}$  to a separate electrode on the body through a  $200\text{k}\Omega$  or higher resistor to limit current into the body according to IEC 60601-1:2005, 8.7.3. If this is utilized then the internal lead bias resistors to  $V_{MID}$  may be disabled if the input signals are within the common-mode input range.

**Table 9. BioZ Latency in Samples and Time as a Function of BioZ Data Rate and Decimation**

BioZ CHANNEL SETTINGS			LATENCY			
INPUT SAMPLE RATE (Hz)	OUTPUT DATA RATE (sps)	DECIMATION RATIO	WITHOUT LPF (INPUT SAMPLES)	WITH LPF (INPUT SAMPLES)	WITHOUT LPF(ms)	WITH LPF (ms)
32,768	64	512	3,397	6,469	103.668	197.418
32,000	62.5	512	3,397	6,469	106.156	202.156
32,000	50	640	5,189	9,029	162.156	282.156
31,968	49.95	640	5,189	9,029	162.319	282.439
32,768	32	1,024	7,557	13,701	230.621	418.121
32,000	31.25	1,024	7,557	13,701	236.156	428.156
32,000	25	1,280	9,605	17,285	300.156	540.156
31,968	24.975	1,280	9,605	17,285	300.457	540.697

**Table 10. BioZ Channel Noise Performance**

GAIN	BANDWIDTH	NOISE		SNR	ENOB
		$\mu\text{V}_{\text{RMS}}$	$\mu\text{V}_{\text{P-P}}$		
V/V	Hz			dB	Bits
10	4	0.23	1.55	101.6	16.6
	8	0.28	1.87	100.0	16.3
	16	0.35	2.34	98.0	16.0
20	4	0.16	1.10	104.9	17.1
	8	0.19	1.27	103.4	16.9
	16	0.26	1.68	100.9	16.5
40	4	0.12	0.78	107.6	17.6
	8	0.16	1.07	104.9	17.1
	16	0.22	1.48	102.0	16.7
80	4	0.11	0.72	108.3	17.7
	8	0.15	1.01	105.3	17.2
	16	0.21	1.42	102.4	16.7

$$\text{SNR} = 20\log(V_{IN}(\text{RMS})/V_N(\text{RMS})), \text{ENOB} = (\text{SNR} - 1.76)/6.02$$

$V_{IN(\text{P-P})} = 100\text{mV}$ ,  $V_{IN\text{RMS}} = 35.4\text{mV}$  for a gain of 10V/V. The input amplitude is reduced accordingly for high gain settings.

## SPI Interface Description

### 32 Bit Normal Mode Read/Write Sequences

The MAX30001G interface is SPI/QSPI/Micro-wire/DSP compatible. The operation of the SPI interface is shown in Figure 1a. Data is strobed into the MAX30001G on SCLK rising edges. The device is programmed and accessed by a 32 cycle SPI instruction framed by a CSB low interval. The content of the SPI operation consists of a one byte command word (comprised of a seven bit address and a Read/Write mode indicator, i.e.,  $A[6:0] + R/\overline{W}$ ) followed by a three-byte data word. The MAX30001G is compatible with CPOL = 0/CPHA = 0 and CPOL = 1/CPHA = 1 modes of operation.

Write mode operations will be executed on the 32nd SCLK rising edge using the first four bytes of data available. In write mode, any data supplied after the 32nd SCLK rising edge will be ignored. Subsequent writes require CSB to de-assert high and then assert low for the next write command. In order to abort a command sequence, the rise of CSB must precede the updating (32nd) rising-edge of SCLK, meeting the  $t_{CSA}$  requirement.

Read mode operations will access the requested data on the 8th SCLK rising edge, and present the MSB of the requested data on the following SCLK falling edge, allowing the  $\mu C$  to sample the data MSB on the 9th SCLK rising edge. Configuration, Status, and FIFO data are all available via normal mode read back sequences. If more than 32 SCLK rising edges are provided in a normal read sequence then the excess edges will be ignored and the device will read back zeros.

If accessing the STATUS register or the ECG or BioZ FIFO memories, all interrupt updates will be made and the internal FIFO read pointer will be incremented in response to the 30th SCLK rising edge, allowing for internal synchronization operations to occur. See the data tag structures used within each FIFO for means of detecting end-of-file (EOF) samples, invalid (empty samples) and other aides for efficiently using and managing normal mode read back operations.

### Burst Mode Read Sequence

The MAX30001G provides commands to read back the ECG or BioZ FIFO memory in a burst mode to increase data transfer efficiency. Burst mode uses different register addresses than the normal read sequence register addresses. The first 32 SCLK cycles operate exactly as described for the normal mode. If the  $\mu C$  continues to provide SCLK edges beyond the 32nd rising edge, the MSB of the next available FIFO word will be presented on the next falling SCLK edge, allowing the  $\mu C$  to sample the MSB of the next word on the 33rd SCLK rising edge. Any affected interrupts and/or FIFO read pointers will be incremented in response to the  $(30+nx24)$ th SCLK rising edge where  $n$  is an integer starting at 0. (i.e., on the 30th, 54th, and 78th SCLK rising-edges for a three-word, burst-mode transfer).

This mode of operation will continue for every 24 cycle sub frame, as long as there is valid data in the FIFO. See the data tag structures used within each FIFO for means of detecting end-of-file (EOF) samples, invalid (empty samples) and other aides for efficiently using and managing burst mode read back operations.

There is no burst mode equivalent in write mode.

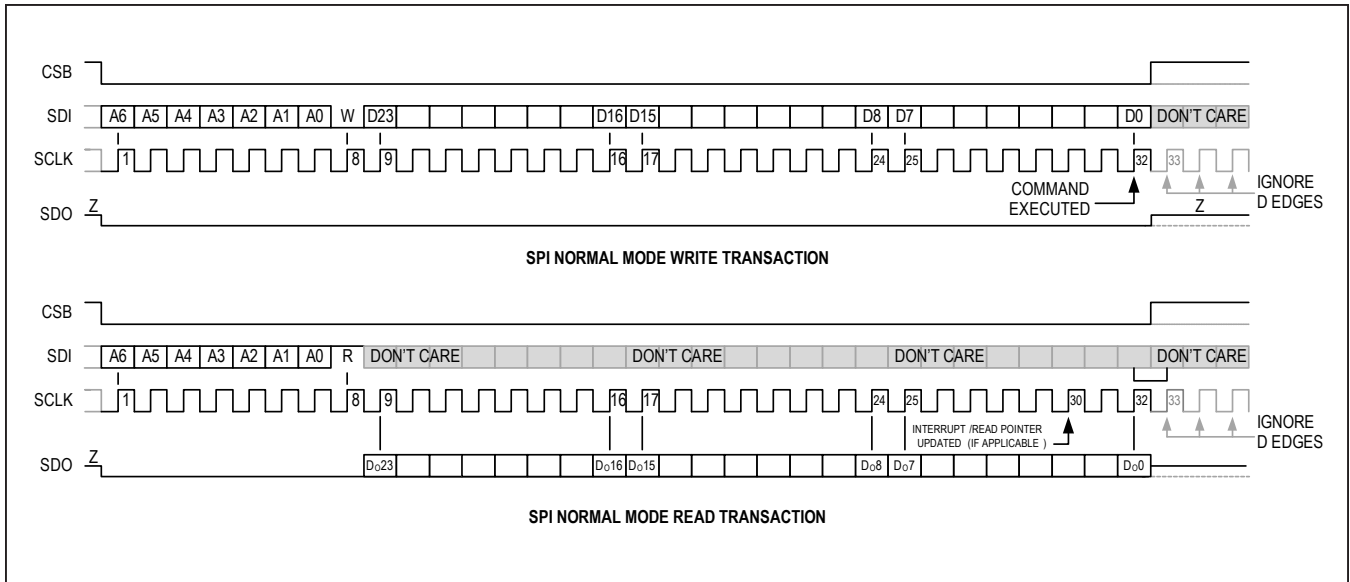

Figure 14. SPI Normal Mode Transaction Diagram

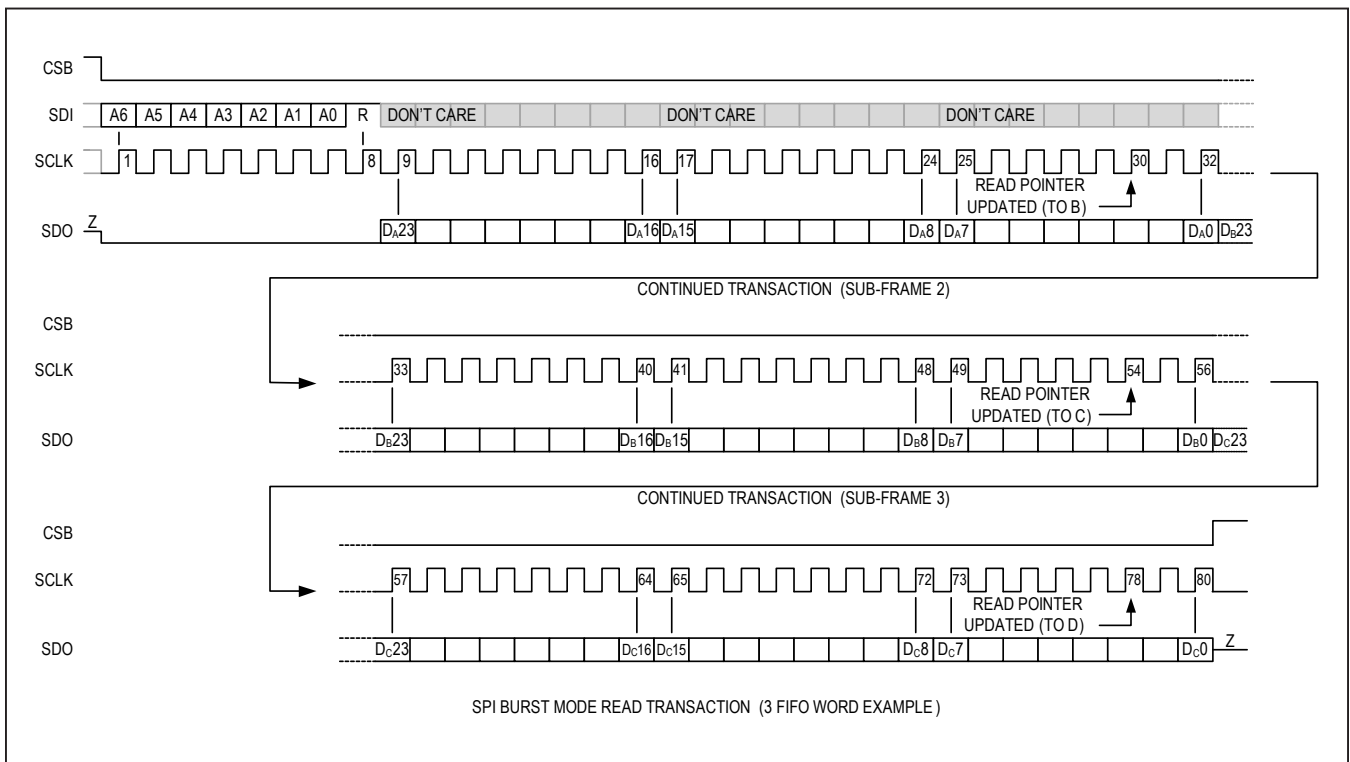

Figure 15. SPI Burst Mode Read Transactions Diagram

User Command and Register Map

REG [6:0]	NAME	R/W MODE	DATA INDEX								
			23/15/7	22/14/6	21/13/5	20/12/4	19/11/3	18/10/2	17/9/1	16/8/0	
0x00	NO-OP	R/W	x/x/x	x/x/x	x/x/x	x/x/x	x/x/x	x/x/x	x/x/x	x/x/x	
0x01	STATUS	R	EINT	EOVF	FSTINT	DCLO FFINT	BINT	BOVF	BOVER	BUNDR	
			BCGMON	x	x	x	LONINT	RRINT	SAMP	PLLINT	
			x	x	BCGMP	BCGMN	LDOFF_PH	LDOFF_PL	LDOFF_NH	LDOFF_NL	
0x02 0x03	EN_INT EN_INT2	R/W	EN_EINT	EN_EOVF	EN_ FSTINT	EN_ DCLOFFINT	EN_BINT	EN_BOVF	EN_BOVER	EN_BUNDR	
			EN_BCGMON	x	x	x	EN_LONINT	EN_RRINT	EN_SAMP	EN_PLLINT	
			x	x	x	x	x	x	INTB_TYPE[1:0]		
0x04	MNGR_INT	R/W	EFIT[4:0]				BFIT[2:0]				
			x	x	x	x	x	x	x	x	
			x	CLR_ FAST	CLR_RRINT[1:0]		x	CLR_SAMP	SAMP_IT[1:0]		
0x05	MNGR_ DYN	R/W	FAST[1:0]		FAST_TH[5:0]						
			BLOFF_HI_IT[7:0]								
			BLOFF_LO_IT[7:0]								
0x08	SW_RST	W	Data Required for Execution = 0x000000								
0x09	SYNCH	W	Data Required for Execution = 0x000000								
0x0A	FIFO_RST	W	Data Required for Execution = 0x000000								
0x0F	INFO	R	0	1	0	1	REV_ID[3:0]				
			x	x	0	1	x	x	x	x	
			x	x	x	x	x	x	x	x	
0x10	CNFG_GEN	R/W	EN_ULP_LON[1:0]		FMSTR[1:0]		EN_ECG	EN_BIOZ	x	x	
			EN_BLOFF[1:0]		EN_DCLOFF[1:0]		IPOL	IMAG[2:0]			
			VTH[1:0]		EN_RBIAS[1:0]		RBIASV[1:0]		RBIASP	RBIASN	
0x12	CNFG_ CAL	R/W	x	EN_VCAL	VMODE	VMAG	x	x	x	x	
			x	FCAL[2:0]			FIFTY	THIGH[10:8]			
			THIGH[7:0]								
0x14	CNFG_ EMUX	R/W	ECG_POL	x	ECG_ OPENP	ECG_ OPENN	ECG_CALP_SEL[1:0]		ECG_CALN_SEL[1:0]		
			x	x	x	x	x	x	x	x	
			x	x	x	x	x	x	x	x	
0x15	CNFG_ ECG	R/W	ECG_RATE[1:0]		x	x	x	x	ECG_GAIN[1:0]		
			x	ECG_ DHPF	ECG_DLPF[1:0]		x	x	x	x	
			x	x	x	x	x	x	x	x	

User Command and Register Map (continued)

REG [6:0]	NAME	R/W MODE	DATA INDEX							
			23/15/7	22/14/6	21/13/5	20/12/4	19/11/3	18/10/2	17/9/1	16/8/0
0x17	CNFG_ BMUX	R/W	x	x	BMUX_ OPENP	BMUX_ OPENN	BMUX_CALP_SEL[1:0]		BMUX_CALN_SEL[1:0]	
			x	x	BMUX_CG_MODE[1:0]		BMUX_EN_ BIST	BMUX_RNOM[2:0]		
			x	BMUX_RMOD[2:0]			x	x	BMUX_FBIST[1:0]	
0x18	CNFG_ BIOZ	R/W	BIOZ_RATE	BIOZ_AHPF[2:0]			EXT_RBIA	LN_BIOZ	BIOZ_GAIN[1:0]	
			BIOZ_DHPF[1:0]		BIOZ_DLPF[1:0]		BIOZ_FCGEN[3:0]			
			BIOZ_ CGMON	BIOZ_CGMAG[2:0]			BIOZ_PHOFF[3:0]			
0x1A	CNFG_ BIOZ_ LC	R/W	BIOZ_ HI_LOB	x	x	x	BIOZ_ LC2X	x		
			x	EN_ BISTR	BISTR[1:0]		x	x	x	x
			BIOZ_CMFB_LC[3:0]				BIOZ_CMAG_LC[3:0]			
0x1D	CNFG_ RTOR1	R/W	WNDW[3:0]				RGAIN[3:0]			
			EN_RTOR	x	PAVG[1:0]		PTSF[3:0]			
			x	x	x	x	x	x	x	x
0x1E	CNFG_ RTOR2	R/W	x	x	HOFF[5:0]					
			x	x	RAVG[1:0]		x	RHSF[2:0]		
			x	x	x	x	x	x	x	x
0x20	ECG_FIFO_ BURST	R+	ECG FIFO Burst Mode Read Back				See FIFO Description for details			
0x21	ECG_FIFO	R	ECG FIFO Normal Mode Read Back				See FIFO Description for details			
0x22	BIOZ_ FIFO_ BURST	R+	BioZ FIFO Burst Mode Read Back				See FIFO Description for details			
0x23	BIOZ_FIFO	R	BioZ FIFO Normal Mode Read Back				See FIFO Description for details			
0x25	RTOR	R	R-to-R Interval Register Read Back				See FIFO Description for details			
0x7F	NO-OP	R/W	x/x/x	x/x/x	x/x/x	x/x/x	x/x/x	x/x/x	x/x/x	x/x/x

**Note:** R/W Mode R+ denotes burst mode.

x = Don't Care



## Register Description

### NO\_OP (0x00 and 0x7F) Registers

No Operation (NO\_OP) registers are read-write registers that have no internal effect on the device. If these registers are read back, DOUT remains zero for the entire SPI transaction. Any attempt to write to these registers is ignored without impact to internal operation.

### STATUS (0x01) Register

STATUS is a read-only register that provides a comprehensive overview of the current status of the device. The first two bytes indicate the state of all interrupt bits (regardless of whether interrupts are enabled in registers EN\_INT (0x02) or EN\_INT2 (0x03)). All interrupt bits are active high. The last byte includes detailed status information for conditions associated with the other interrupt bits.

**Table 11. STATUS (0x01) Register Map**

REG	NAME	R/W	23/15/7	22/14/6	21/13/5	20/12/4	19/11/3	18/10/2	17/9/1	16/8/0
0x01	STATUS	R	EINT	EOVF	FSTINT	DCLOFFINT	BINT	BOVF	BOVER	BUNDR
			BCGMON	x	x	x	LONINT	RRINT	SAMP	PLLINT
			x	x	BCGMP	BCGMN	LDOFF_ PH	LDOFF_ PL	LDOFF_ NH	LDOFF_ NL

**Table 12. Status (0x01) Register Meaning**

INDEX	NAME	MEANING
D[23]	EINT	ECG FIFO Interrupt. Indicates that ECG records meeting/exceeding the ECG FIFO Interrupt Threshold (EFIT) are available for readback. Remains active until ECG FIFO is read back to the extent required to clear the EFIT condition.
D[22]	EOVF	ECG FIFO Overflow. Indicates that the ECG FIFO has overflowed and the data record has been corrupted. Remains active until a FIFO Reset (recommended) or SYNCH operation is issued.
D[21]	FSTINT	ECG Fast Recovery Mode. Issued when the ECG Fast Recovery Mode is engaged (either manually or automatically). Status and Interrupt Clear behavior is defined by CLR_FAST, see MNGR_INT for details.
D[20]	DCLOFFINT	DC Lead-Off Detection Interrupt. Indicates that the MAX30001G has determined it is in an ECG leads off condition (as selected in CNFG_GEN) for more than 90ms. Remains active as long as the leads-off condition persists, then held until cleared by STATUS read back (32nd SCLK).
D[19]	BINT	BioZ FIFO Interrupt. Indicates BioZ records meeting/exceeding the BioZ FIFO Interrupt Threshold (BFIT) are available for read back. Remains active until BioZ FIFO is read back to the extent required to clear the BFIT condition.
D[18]	BOVF	BioZ FIFO Overflow. Indicates the BioZ FIFO has overflowed and the data record has been corrupted. Remains active until a FIFO Reset (recommended) or SYNCH operation is issued.
D[17]	BOVER	BioZ Over Range. Indicates the BioZ output magnitude has exceeded the BioZ High Threshold (BLOFF_HI_IT) for at least 100ms, recommended for use in 2 and 4 electrode BioZ Lead Off detection. Remains active as long as the condition persists, then held until cleared by STATUS read back (32nd SCLK).

**Table 12. Status (0x01) Register Meaning (continued)**

INDEX	NAME	MEANING
D[16]	BUNDR	BioZ Under Range. Indicates the BioZ output magnitude has been bounded by the BioZ Low Threshold (BLOFF_LO_IT) for at least 1.7 seconds, recommended for use in 4 electrode BioZ Lead Off detection. Remains active as long as the condition persists, then held until cleared by STATUS read back (32nd SCLK).
D[15]	BCGMON	BioZ Current Generator Monitor. Indicates the DRVP and/or DRVN current generator has been in a Lead Off condition for at least 128ms, recommended for use in 4 electrode BioZ Lead Off detection. Remains active as long as the condition persists, then held until cleared by STATUS read back (32nd SCLK).
D[11]	LONINT	Ultra-Low Power (ULP) Leads-On Detection Interrupt. Indicates that the MAX30001G has determined it is in a leads-on condition (as selected in CNFG_GEN). LONINT is asserted whenever EN_ULP_LON[1:0] in register CNFG_GEN is set to either 01 or 10 to indicate that the ULP leads on detection mode has been enabled. The STATUS register has to be read back once after ULP leads on detection mode has been activated to clear LONINT and enable leads on detection. LONINT remains active while the leads-on condition persists, then held until cleared by STATUS read back (32nd SCLK).
D[10]	RRINT	ECG R-to-R Detector R Event Interrupt. Issued when the R-to-R detector has identified a new R event. Clear behavior is defined by CLR_RRINT[1:0]; see MNGR_INT for details.
D[9]	SAMP	Sample Synchronization Pulse. Issued on the ECG base-rate sampling instant, for use in assisting $\mu$ C monitoring and synchronizing other peripheral operations and data, generally recommended for use as a dedicated interrupt. Frequency is selected by SAMP_IT[1:0], see MNGR_INT for details. Clear behavior is defined by CLR_SAMP, see MNGR_INT for details.
D[8]	PLLINT	PLL Unlocked Interrupt. Indicates that the PLL has not yet achieved or has lost its phase lock. PLLINT will only be asserted when the PLL is powered up and active (ECG and/or BioZ Channel enabled). Remains asserted while the PLL unlocked condition persists, then held until cleared by STATUS read back (32nd SCLK).
D[5]	BCGMP	BioZ Current Generator Monitor Positive Output. Indicates the DRVP current generator has been in a Lead Off condition for at least 128ms. This is not strictly an interrupt bit, but is a detailed status bit, covered by the BCGMON interrupt bit.
D[4]	BCGMN	BioZ Current Generator Monitor Negative Output. Indicates the DRVN current generator has been in a Lead Off condition for at least 128ms. This is not strictly an interrupt bit, but is a detailed status bit, covered by the BCGMON interrupt bit.
D[3]	LDOFF_PH	DC Lead Off Detection Detailed Status. Indicates that the MAX30001G has determined (as selected by CNFG_GEN): ECGP is above the high threshold ( $V_{THH}$ ), ECGP is below the low threshold ( $V_{THL}$ ), ECGN is above the high threshold ( $V_{THH}$ ), ECGN is below the low threshold ( $V_{THL}$ ), respectively. Remains active as long as the leads-off detection is active and the leads-off condition persists, then held until cleared by STATUS read back (32nd SCLK). LDOFF_PH to LDOFF_NL are detailed status bits that are asserted at the same time as DCLOFFINT.
D[2]	LDOFF_PL	
D[1]	LDOFF_NH	
D[0]	LDOFF_NL	

**EN\_INT (0x02) and EN\_INT2 (0x03) Registers**

EN\_INT and EN\_INT2 are read/write registers that govern the operation of the INTB output and INT2B output, respectively. The first two bytes indicate which interrupt input bits are included in the interrupt output OR term (ex. a one in an EN\_INT register indicates that the corresponding input bit is included in the INTB interrupt output OR term). See the STATUS register for detailed descriptions of the interrupt bits. The power-on reset state of all EN\_INT bits is 0 (ignored by INT).

EN\_INT and EN\_INT2 can also be used to mask persistent interrupt conditions in order to perform other interrupt-driven operations until the persistent conditions are resolved.

INTB\_TYPE[1:0] allows the user to select between a CMOS or an open-drain NMOS mode INTB output. If using open-drain mode, an option for an internal 125kΩ pullup resistor is also offered.

All INTB and INT2B types are active-low (INTB low indicates the device requires servicing by the μC); however, the open-drain mode allows the INTB line to be shared with other devices in a wired-or configuration.

In general, it is suggested that INT2B be used to support specialized/dedicated interrupts of use in specific applications, such as the self-clearing versions of SAMP or RRINT.

**Table 13. EN\_INT (0x02) and EN\_INT2 (0x03) Register Maps**

REG	NAME	R/W	23/15/7	22/14/6	21/13/5	20/12/4	19/11/3	18/10/2	17/9/1	16/8/0
0x02 0x03	EN_INT EN_INT2	R/W	EN_EINT	EN_EOVF	EN_FSTINT	EN_DCL OFFINT	EN_BINT	EN_BOVF	EN_BOVER	EN_BUNDR
			EN_BCGMON	x	x	x	EN_LONINT	EN_RRINT	EN_SAMP	EN_PLLINT
			x	x	x	x	x	x	INTB_TYPE[1:0]	

**Table 14. EN\_INT (0x02 and 0x03) Register Meaning**

INDEX	NAME	DEFAULT	FUNCTION
D[23:8]	EN_EINT EN_EOVF EN_FSTINT EN_DCL OFFINT EN_BINT EN_BOVF EN_BOVER EN_BUNDR EN_BCGMON EN_LONINT EN_RRINT EN_SAMP EN_PLLINT	0x0000	Interrupt Enables for interrupt bits in STATUS[23:8] 0 = Individual interrupt bit is not included in the interrupt OR term 1 = Individual interrupt bit is included in the interrupt OR term
D[1:0]	INTB_TYPE[1:0]	11	INTB Port Type (EN_INT Selections) 00 = Disabled (high impedance) 01 = CMOS Driver 10 = Open-Drain NMOS Driver 11 = Open-Drain NMOS Driver with Internal 125kΩ Pullup Resistance
		11	INT2B Port Type (EN_INT2 Selections) 00 = Disabled (high impedance) 01 = CMOS Driver 10 = Open-Drain nMOS Driver 11 = Open-Drain nMOS Driver with Internal 125kΩ Pullup Resistance

**MNGR\_INT (0x04)**

MNGR\_INT is a read/write register that manages the operation of the configurable interrupt bits in response to ECG and BioZ FIFO conditions (see the STATUS register and ECG and BioZ FIFO descriptions for more details). Finally, this register contains the configuration bits supporting the sample synchronization pulse (SAMP) and RTOR heart rate detection interrupt (RRINT).

**Table 15. MNGR\_INT (0x04) Register Map**

REG	NAME	R/W	23/15/7	22/14/6	21/13/5	20/12/4	19/11/3	18/10/2	17/9/1	16/8/0	
0x04	MNGR_INT	R/W	EFIT[4:0]					BFIT[2:0]			
			x	x	x	x	x	x	x	x	
			x	CLR_FAST	CLR_RRINT[1:0]		x	CLR_SAMP	SAMP_IT[1:0]		

**Table 16. MNGR\_INT (0x04) Register Functionality**

INDEX	NAME	DEFAULT	FUNCTION
D[23:19]	EFIT[4:0]	01111	ECG FIFO Interrupt Threshold (issues EINT based on number of unread FIFO records) 00000 to 11111 = 1 to 32, respectively (i.e. EFIT[4:0]+1 unread records)
D[18:16]	BFIT[2:0]	011	BioZ FIFO Interrupt Threshold (issues BINT based on number of unread FIFO records) 000 to 111 = 1 to 8, respectively (i.e. BFIT[2:0]+1 unread records)
D[6]	CLR_FAST	0	FAST MODE Interrupt Clear Behavior: 0 = FSTINT remains active until the FAST mode is disengaged (manually or automatically), then held until cleared by STATUS read back (32nd SCLK). 1 = FSTINT remains active until cleared by STATUS read back (32nd SCLK), even if the MAX30001G remains in FAST recovery mode. Once cleared, FSTINT will not be re-asserted until FAST mode is exited and re-entered, either manually or automatically.
D[5:4]	CLR_RRINT[1:0]	00	RTOR R Detect Interrupt (RRINT) Clear Behavior: 00 = Clear RRINT on STATUS Register Read Back 01 = Clear RRINT on RTOR Register Read Back 10 = Self-Clear RRINT after one ECG data rate cycle, approximately 2ms to 8ms 11 = Reserved. Do not use.
D[2]	CLR_SAMP	1	Sample Synchronization Pulse (SAMP) Clear Behavior: 0 = Clear SAMP on STATUS Register Read Back (recommended for debug/evaluation only). 1 = Self-clear SAMP after approximately one-fourth of one data rate cycle.
D[1:0]	SAMP_IT[1:0]	00	Sample Synchronization Pulse (SAMP) Frequency 00 = issued every sample instant 01 = issued every 2nd sample instant 10 = issued every 4th sample instant 11 = issued every 16th sample instant

**MNGR\_DYN (0x05)**

MNGR\_DYN is a read/write register that manages the settings of any general/dynamic modes within the device. The ECG Fast Recovery modes and thresholds are managed here. This register also contains the interrupt thresholds for BioZ AC Lead-Off Detection (see CNFG\_GEN for more details). Unlike many CNFG registers, changes to dynamic modes do not impact FIFO operations or require a SYNCH operation (though the affected circuits may require time to settle, resulting in invalid/corrupted FIFO output voltage information during the settling interval).

**Table 17. MNGR\_DYN (0x05) Register Map**

REG	NAME	R/W	23/15/7	22/14/6	21/13/5	20/12/4	19/11/3	18/10/2	17/9/1	16/8/0
0x05	MNGR_DYN	R/W	FAST[1:0]		FAST_TH[5:0]					
			BLOFF_HI_IT[7:0]							
			BLOFF_LO_IT[7:0]							

**Table 18. MNGR\_DYN (0x05) Register Functionality**

INDEX	NAME	DEFAULT	FUNCTION
D[23:22]	FAST[1:0]	00	ECG Channel Fast Recovery Mode Selection (ECG High Pass Filter Bypass): 00 = Normal Mode (Fast Recovery Mode Disabled) 01 = Manual Fast Recovery Mode Enable (remains active until disabled) 10 = Automatic Fast Recovery Mode Enable (Fast Recovery automatically activated when/while ECG outputs are saturated, using FAST_TH). 11 = Reserved. Do not use.
D[21:16]	FAST_TH[5:0]	0x3F	Automatic Fast Recovery Threshold: If FAST[1:0] = 10 and the output of an ECG measurement exceeds the symmetric thresholds defined by $2048 * \text{FAST\_TH}$ for more than 125ms, the Fast Recovery mode will be automatically engaged and remain active for 500ms. For example, the default value (FAST_TH = 0x3F) corresponds to an ECG output upper threshold of 0x1F800, and an ECG output lower threshold of 0x20800.
D[15:8]	BLOFF_HI_IT[7:0]	0xFF	BioZ AC Lead Off Over-Range Threshold If EN_BLOFF[1:0] = 1x and the ADC output of a BioZ measurement exceeds the symmetric thresholds defined by $\pm 2048 * \text{BLOFF\_HI\_IT}$ for over 128ms, the BOVER interrupt bit will be asserted. For example, the default value (BLOFF_HI_IT = 0xFF) corresponds to a BioZ output upper threshold of 0x7F800 or about 99.6% of the full scale range, and a BioZ output lower threshold of 0x80800 or about 0.4% of the full scale range with the LSB weight $\approx 0.4\%$ .
D[7:0]	BLOFF_LO_IT[7:0]	0xFF	BioZ AC Lead Off Under-Range Threshold If EN_BLOFF[1:0] = 1x and the output of a BioZ measurement is bounded by the symmetric thresholds defined by $\pm 32 * \text{BLOFF\_LO\_IT}$ for over 128ms, the BUNDR interrupt bit will be asserted.

**SW\_RST (0x08)**

SW\_RST (Software Reset) is a write-only register/command that resets the MAX30001G to its original default conditions at the end of the SPI SW\_RST transaction (i.e. the 32nd SCLK rising edge). Execution occurs only if DIN[23:0] = 0x000000. The effect of a SW\_RST is identical to power-cycling the device.

**Table 19. SW\_RST (0x08) Register Map**

REG	NAME	R/W	23/15/7	22/14/6	21/13/5	20/12/4	19/11/3	18/10/2	17/9/1	16/8/0
0x08	SW_RST	W	D[23:16] = 0x00							
			D[15:8] = 0x00							
			D[7:0] = 0x00							

**SYNCH (0x09)**

SYNCH (Synchronize) is a write-only register/command that begins new ECG/BioZ operations and recording, beginning on the internal MSTR clock edge following the end of the SPI SYNCH transaction (i.e. the 32nd SCLK rising edge). Execution occurs only if DIN[23:0] = 0x000000. In addition to resetting and synchronizing the operations of any active ECG, RtoR and BioZ circuitry, SYNCH will also reset and clear the FIFO memories and the DSP filters (to midscale), allowing the user to effectively set the “Time Zero” for the FIFO records. No configuration settings are impacted. For best results, users should wait until the PLL has achieved lock before synchronizing if the CNFG\_GEN settings have been altered.

Once the device is initially powered up, it will need to be fully configured prior to launching recording operations. Likewise, anytime a change to CNFG\_GEN, CNFG\_ECG, or CNFG\_BIOZ registers are made there may be discontinuities in the ECG and BioZ records and possibly changes to the size of the time steps recorded in the FIFOs. The SYNCH command provides a means to restart operations cleanly following any such disturbances.

During multi-channel operations, if a FIFO overflow event occurs and a portion of the record is lost, it is recommended to use the SYNCH command to recover and restart the recording (avoiding issues with missing data in one or more channel records). Note that the two channel records cannot be directly synchronized within the device, due to significant differences in group delays, depending on filter selections—alignment of the records will have to be done externally.

**Table 20. SYNCH (0x09) Register Map**

REG	NAME	R/W	23/15/7	22/14/6	21/13/5	20/12/4	19/11/3	18/10/2	17/9/1	16/8/0
0x09	SYNCH	W	D[23:16] = 0x00							
			D[15:8] = 0x00							
			D[7:0] = 0x00							

**FIFO\_RST (0x0A)**

FIFO\_RST (FIFO Reset) is a write-only register/command that begins a new ECG and BioZ recordings by resetting the FIFO memories and resuming the record with the next available ECG and BioZ data. Execution occurs only if DIN[23:0] = 0x000000. Unlike the SYNCH command, the operations of any active ECG, R-to-R and BioZ circuitry are not impacted by FIFO\_RST, so no settling/recovery transients apply. FIFO\_RST can also be used to quickly recover from a FIFO overflow state (recommended for single ECG or BioZ channel use, see above).

**Table 21. FIFO\_RST (0x0A) Register Map**

REG	NAME	R/W	23/15/7	22/14/6	21/13/5	20/12/4	19/11/3	18/10/2	17/9/1	16/8/0
0x0A	FIFO_RST	W	D[23:16] = 0x00							
			D[15:8] = 0x00							
			D[7:0] = 0x00							

**INFO (0x0F)**

INFO is a read-only register that provides information about the MAX30001G. The first nibble contains an alternating bit pattern to aide in interface verification. The second nibble contains the revision ID. The third nibble includes part ID information.

**Note:** Due to internal initialization procedures, this command will not read-back valid data if it is the first command executed following either a power-cycle event, or a SW\_RST event.

**Table 22. INFO (0x0F) Register Map**

REG	NAME	R/W	23/15/7	22/14/6	21/13/5	20/12/4	19/11/3	18/10/2	17/9/1	16/8/0
0x0F	INFO	R	0	1	0	1	REV_ID[3:0]			
			x	x	0	1	x	x	x	x
			x	x	x	x	x	x	x	x

**Table 23. INFO (0x0F) Register Meaning**

INDEX	NAME	MEANING	VALUE
D[19:16]	REV_ID[3:0]	Revision ID	0x4

**CNFG\_GEN (0x10)**

CNFG\_GEN is a read/write register which governs general settings, most significantly the master clock rate for all internal timing operations. Anytime a change to CNFG\_GEN is made, there may be discontinuities in the ECG and BioZ records and possibly changes to the size of the time steps recorded in the FIFOs. The SYNCH command can be used to restore internal synchronization resulting from configuration changes. Note when EN\_ECG and EN\_BIOZ are both logic-low, the device is in one of two ultra-low power modes (determined by EN\_ULP\_LON).

**Table 24. CNFG\_GEN (0x10) Register Map**

REG	NAME	R/W	23/15/7	22/14/6	21/13/5	20/12/4	19/11/3	18/10/2	17/9/1	16/8/0
0x10	CNFG_GEN	R/W	EN_ULP_LON[1:0]		FMSTR[1:0]		EN_ECG	EN_BIOZ	x	x
			EN_BLOFF[1:0]		EN_DCLOFF[1:0]		IPOL	IMAG[2:0]		
			VTH[1:0]		EN_RBIAS[1:0]		RBIASV[1:0]		RBIASP	RBIASN

**Table 25. CNFG\_GEN (0x10) Register Functionality**

INDEX	NAME	DEFAULT	FUNCTION
D[23:22]	EN_ULP_LON [1:0]	00	Ultra-Low Power Lead-On Detection Enable 00 = ULP Lead-On Detection disabled 01 = ECG ULP Lead-On Detection enabled 10 = Reserved. Do not use. 11 = Reserved. Do not use. ULP mode is only active when the ECG channel is powered down/disabled.

Table 25. CNFG\_GEN (0x10) Register Functionality (continued)

INDEX	NAME	DEFAULT	FUNCTION
D[21:20]	FMSTR[1:0]	00	Master Clock Frequency. Selects the Master Clock Frequency (FMSTR), and Timing Resolution (T <sub>RES</sub> ), which also determines the ECG and CAL timing characteristics. These are generated from FCLK, which is always 32.768kHz. 00 = F <sub>MSTR</sub> = 32768Hz, T <sub>RES</sub> = 15.26μs (512Hz ECG progressions) 01 = F <sub>MSTR</sub> = 32000Hz, T <sub>RES</sub> = 15.63μs (500Hz ECG progressions) 10 = F <sub>MSTR</sub> = 32000Hz, T <sub>RES</sub> = 15.63μs (200Hz ECG progressions) 11 = F <sub>MSTR</sub> = 31968.78Hz, T <sub>RES</sub> = 15.64μs (199.8049Hz ECG progressions)
D[19]	EN_ECG	0	ECG Channel Enable 0 = ECG Channel disabled 1 = ECG Channel enabled Note: The ECG channel must be enabled to allow R-to-R operation.
D[18]	EN_BIOZ	0	BioZ Channel Enable 0 = BioZ Channel disabled 1 = BioZ Channel enabled
D[15:14]	EN_BLOFF[1:0]	00	BioZ Digital Lead Off Detection Enable 00 = Digital Lead Off Detection disabled 01 = Lead Off Under Range Detection, 4 electrode BioZ applications 10 = Lead Off Over Range Detection, 2 and 4 electrode BioZ applications 11 = Lead Off Over & Under Range Detection, 4 electrode BioZ applications AC Method, requires active BioZ Channel, enables BOVER & BUNDR interrupt behavior. Uses BioZ excitation current set in CNFG_BIOZ with digital thresholds set in MNDR_DYN.
D[13:12]	EN_DCLOFF	00	DC Lead-Off Detection Enable 00 = DC Lead-Off Detection disabled 01 = DCLOFF Detection applied to the ECGP/N pins 10 = Reserved. Do not use. 11 = Reserved. Do not use. DC Method, requires active selected channel, enables DCLOFF interrupt and status bit behavior. Uses current sources and comparator thresholds set below.
D[11]	DCLOFF_IPOL	0	DC Lead-Off Current Polarity (if current sources are enabled/connected) 0 = ECGP - Pullup ECGN – Pulldown 1 = ECGP - Pulldown ECGN – Pullup
D[10:8]	IMAG[2:0]	000	DC Lead-Off Current Magnitude Selection 000 = 0nA (Disable and Disconnect Current Sources) 001 = 5nA 010 = 10nA 011 = 20nA 100 = 50nA 101 = 100nA 110 = Reserved. Do not use. 111 = Reserved. Do not use.



**Table 25. CNFG\_GEN (0x10) Register Functionality (continued)**

INDEX	NAME	DEFAULT	FUNCTION
D[7:6]	VTH[1:0]	00	DC Lead-Off Voltage Threshold Selection 00 = $V_{MID} \pm 300mV$ 01 = $V_{MID} \pm 400mV$ 10 = $V_{MID} \pm 450mV$ 11 = $V_{MID} \pm 500mV$
D[5:4]	EN_RBIAS[1:0]	00	Enable and Select Resistive Lead Bias Mode 00 = Resistive Bias disabled 01 = ECG Resistive Bias enabled if EN_ECG is also enabled 10 = BioZ Resistive Bias enabled if EN_BIOZ is also enabled 11 = Reserved. Do not use. If EN_ECG or EN_BIOZ is not asserted at the same time or prior to EN_RBIAS[1:0] being enabled, then EN_RBIAS[1:0] will remain set to 00.
D[3:2]	RBIASV[1:0]	01	Resistive Bias Mode Value Selection 00 = $R_{BIAS} = 50M\Omega$ 01 = $R_{BIAS} = 100M\Omega$ 10 = $R_{BIAS} = 200M\Omega$ 11 = Reserved. Do not use.
D[1]	RBIASP	0	Enables Resistive Bias on Positive Input 0 = ECGP/BIP is not resistively connected to $V_{MID}$ 1 = ECGP/BIN is connected to $V_{MID}$ through a resistor (selected by RBIASV).
D[0]	RBIASN	0	Enables Resistive Bias on Negative Input 0 = ECGN is not resistively connected to $V_{MID}$ 1 = ECGN is connected to $V_{MID}$ through a resistor (selected by RBIASV).

Table 26 shows the ECG and BioZ data rates that can be realized with various setting of FMSTR, along with RATE configuration bits available in the CNFG\_ECG and CNFG\_BIOZ registers. Note FMSTR also determines the timing resolution of the CAL waveform generator.

**Table 26. Master Frequency Summary Table**

FMSTR [1:0]	MASTER FREQUENCY ( $f_{MSTR}$ ) (Hz)	ECG DATA RATE (ECG_RATE) (sps)	RTOR TIMING RESOLUTION (RTOR_RES) (ms)	CALIBRATION TIMING RESOLUTION (CAL_RES) ( $\mu s$ )	BioZ DATA RATES (B_RATE) (sps)
00	32,768	00 = 512 01 = 256 10 = 128	7.8125	30.52	0 = 64 1 = 32
01	32,000	00 = 500 01 = 250 10 = 125	8.000	31.25	0 = 62.50 1 = 31.25
10	32,000	10 = 200	8.000	31.25	0 = 50 1 = 25
11	31,968	10 = 199.8049	8.008	31.28	0 = 49.95 1 = 24.98

**CNFG\_CAL (0x12)**

CNFG\_CAL is a read/write register that configures the operation, settings, and function of the Internal Calibration Voltage Sources (VCALP and VCALN). The output of the voltage sources can be routed to the ECG or BioZ/PACE inputs through the channel input MUXes to facilitate end-to-end testing operations. Note if a VCAL source is applied to a connected device, it is recommended that the appropriate channel MUX switches be placed in the OPEN position.

**Table 27. CNFG\_CAL (0x12) Register Map**

REG	NAME	R/W	23/15/7	22/14/6	21/13/5	20/12/4	19/11/3	18/10/2	17/9/1	16/8/0
0x12	CNFG_CAL	R/W	x	EN_VCAL	VMODE	VMAG	x	x	x	x
			x	FCAL[2:0]			FIFTY	THIGH[10:8]		
			THIGH[7:0]							

**Table 28. CNFG\_CAL (0x12) Register Functionality**

INDEX	NAME	DEFAULT	FUNCTION
D[22]	EN_VCAL	0	Calibration Source (VCALP and VCALN) Enable 0 = Calibration sources and modes disabled 1 = Calibration sources and modes enabled
D[21]	VMODE	0	Calibration Source Mode Selection 0 = Unipolar, sources swing between $V_{MID} \pm V_{MAG}$ and $V_{MID}$ 1 = Bipolar, sources swing between $V_{MID} + V_{MAG}$ and $V_{MID} - V_{MAG}$
D[20]	VMAG	0	Calibration Source Magnitude Selection ( $V_{MAG}$ ) 0 = 0.25mV 1 = 0.50mV
D[14:12]	FCAL[2:0]	100	Calibration Source Frequency Selection (FCAL) 000 = $F_{MSTR}/128$ (256, 250, or 249.75Hz) 001 = $F_{MSTR}/512$ (64, 62.5, or 62.4375Hz) 010 = $F_{MSTR}/2048$ (16, 15.625, or 15.609375Hz) 011 = $F_{MSTR}/8192$ (4, 3.90625, or 3.902344Hz) 100 = $F_{MSTR}/2^{15}$ (1, 0.976563, or 0.975586Hz) 101 = $F_{MSTR}/2^{17}$ (0.25, 0.24414, or 0.243896Hz) 110 = $F_{MSTR}/2^{19}$ (0.0625, 0.061035Hz, or 0.060974Hz) 111 = $F_{MSTR}/2^{21}$ (0.015625, 0.015259, or 0.015244Hz) Actual frequencies are determined by FMSTR selection (see CNFG_GEN for details), frequencies in parenthesis are based on 32,768, 32,000, or 31,968Hz clocks ( $FMSTR[1:0] = 00$ ). $TCAL = 1/FCAL$ .
D[11]	FIFTY	1	Calibration Source Duty Cycle Mode Selection 0 = Use CAL_THIGH to select time high for VCALP and VCALN 1 = THIGH = 50% ( $CAL\_THIGH[10:0]$ are ignored)
D[10:0]	THIGH[10:0]	0x000	Calibration Source Time High Selection If FIFTY = 1, $t_{HIGH} = 50\%$ (and $THIGH[10:0]$ are ignored), otherwise $THIGH = THIGH[10:0] \times CAL\_RES$ $CAL\_RES$ is determined by FMSTR selection (see CNFG_GEN for details); for example, if $FMSTR[1:0] = 00$ , $CAL\_RES = 30.52\mu s$ .

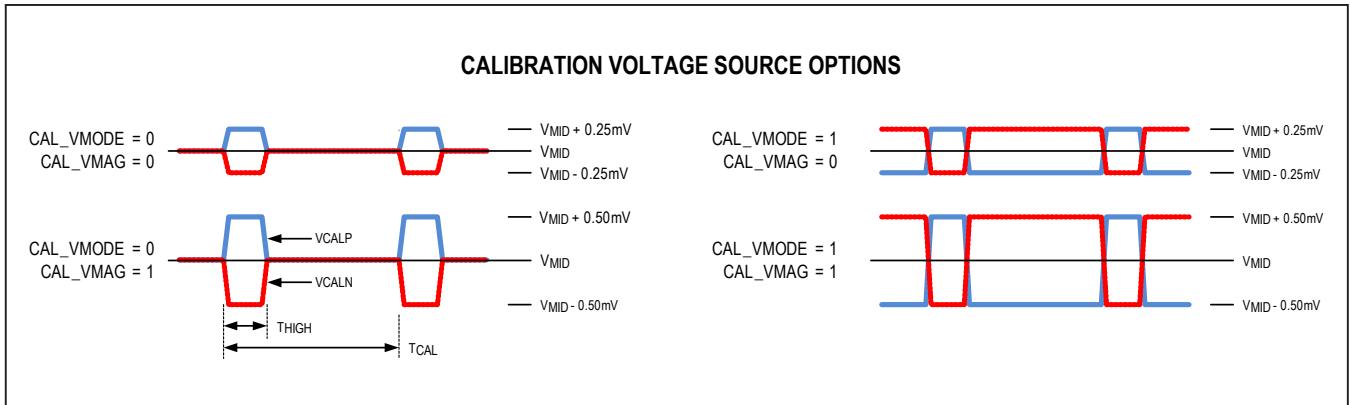

Figure 16. Calibration Voltage Source Options

**CNFG\_EMUX (0x14)**

CNFG\_EMUX is a read/write register which configures the operation, settings, and functionality of the Input Multiplexer associated with the ECG channel.

**Table 29. CNFG\_EMUX (0x14) Register Map**

REG	NAME	R/W	23/15/7	22/14/6	21/13/5	20/12/4	19/11/3	18/10/2	17/9/1	16/8/0
0x14	CNFG_EMUX	R/W	ECG_POL	x	ECG_OPENP	ECG_OPENN	ECG_CALP_SEL[1:0]		ECG_CALN_SEL[1:0]	
			x	x	x	x	x	x	x	x
			x	x	x	x	x	x	x	x

**Table 30. CNFG\_EMUX (0x14) Register Functionality**

INDEX	NAME	DEFAULT	FUNCTION
D[23]	ECG_POL	0	ECG Input Polarity Selection 0 = Non-inverted 1 = Inverted
D[21]	ECG_OPENP	1	Open the ECGP Input Switch (most often used for testing and calibration) 0 = ECGP is internally connected to the ECG AFE Channel 1 = ECGP is internally isolated from the ECG AFE Channel
D[20]	ECG_OPENN	1	Open the ECGN Input Switch (most often used for testing and calibration) 0 = ECGN is internally connected to the ECG AFE Channel 1 = ECGN is internally isolated from the ECG AFE Channel
D[19:18]	ECG_CALP_SEL[1:0]	00	ECGCP Calibration Selection 00 = No calibration signal applied 01 = Input is connected to V_MID 10 = Input is connected to VCALP (only available if CAL_EN_VCAL = 1) 11 = Input is connected to VCALN (only available if CAL_EN_VCAL = 1)
D[17:16]	ECG_CALN_SEL[1:0]	00	ECGNC Calibration Selection 00 = No calibration signal applied 01 = Input is connected to V_MID 10 = Input is connected to VCALP (only available if CAL_EN_VCAL = 1) 11 = Input is connected to VCALN (only available if CAL_EN_VCAL = 1)

**CNFG\_ECG (0x15)**

CNFG\_ECG is a read/write register which configures the operation, settings, and functionality of the ECG channel. Anytime a change to CNFG\_ECG is made, there may be discontinuities in the ECG record and possibly changes to the size of the time steps recorded in the ECG FIFO. The SYNCH command can be used to restore internal synchronization resulting from configuration changes.

**Table 31. CNFG\_ECG (0x15) Register Map**

REG	NAME	R/W	23/15/7	22/14/6	21/13/5	20/12/4	19/11/3	18/10/2	17/9/1	16/8/0
0x15	CNFG_ECG	R/W	ECG_RATE[1:0]		x	x	x	x	ECG_GAIN[1:0]	
			x	ECG_DHPF	ECG_DLPPF[1:0]		x	x	x	x
			x	x	x	x	x	x	x	x

**Table 32. CNFG\_ECG (0x15) Register Functionality**

INDEX	NAME	DEFAULT	FUNCTION
D[23:22]	ECG_RATE[1:0]	10	ECG Data Rate (also dependent on FMSTR selection, see CNFG_GEN Table 33):
			FMSTR = 00: $f_{MSTR} = 32768\text{Hz}$ , $t_{RES} = 15.26\mu\text{s}$ (512Hz ECG progressions) 00 = 512sps 01 = 256sps 10 = 128sps 11 = Reserved. Do not use.
			FMSTR = 01: $f_{MSTR} = 32000\text{Hz}$ , $t_{RES} = 15.63\mu\text{s}$ (500Hz ECG progressions) 00 = 500sps 01 = 250sps 10 = 125sps 11 = Reserved. Do not use.
			FMSTR = 10: $f_{MSTR} = 32000\text{Hz}$ , $t_{RES} = 15.63\mu\text{s}$ (200Hz ECG progressions) 00 = Reserved. Do not use. 01 = Reserved. Do not use. 10 = 200sps 11 = Reserved. Do not use.
			FMSTR = 11: $f_{MSTR} = 31968\text{Hz}$ , $t_{RES} = 15.64\mu\text{s}$ (199.8Hz ECG progressions) 00 = Reserved. Do not use. 01 = Reserved. Do not use. 10 = 199.8sps 11 = Reserved. Do not use.

**Table 32. CNFG\_ECG (0x15) Register Functionality (continued)**

INDEX	NAME	DEFAULT	FUNCTION
D[17:16]	ECG_GAIN[1:0]	00	ECG Channel Gain Setting 00 = 20V/V 01 = 40V/V 10 = 80V/V 11 = 160V/V
D[14]	ECG_DHPF	1	ECG Channel Digital High-Pass Filter Cutoff Frequency 0 = Bypass (DC) 1 = 0.50Hz
D[13:12]	ECG_DLPF[1:0]	01	ECG Channel Digital Low-Pass Filter Cutoff Frequency 00 = Bypass (Decimation only, no FIR filter applied) 01 = approximately 40Hz (Except for 125 and 128sps settings, see Table 33) 10 = approximately 100Hz (Available for 512, 256, 500, and 250sps ECG Rate selections only) 11 = approximately 150Hz (Available for 512 and 500sps ECG Rate selections only) Note: See Table 33. If an unsupported DLPF setting is specified, the 40Hz setting (ECG_DLPF[1:0] = 01) will be used internally; the CNFG_ECG register will continue to hold the value as written, but return the effective internal value when read back.

**Table 33. Supported ECG\_RATE and ECG\_DLPF Options**

CNFG_GEN FMSTR[1:0]	ECG_RATE[1:0] SAMPLE RATE (sps)	ECG_DLPF[1:0]/DIGITAL LPF CUTOFF			
		00	01 (Hz)	10 (Hz)	11 (Hz)
00 = 32,768Hz	00 = 512	Bypass	40.96	102.4	153.6
	01 = 256	Bypass	40.96	102.4	<b>40.96</b>
	10 = 128	Bypass	28.35	<b>28.35</b>	<b>28.35</b>
01 = 32,000Hz	00 = 500	Bypass	40.00	100.0	150.0
	01 = 250	Bypass	40.00	100.0	<b>40.00</b>
	10 = 125	Bypass	27.68	<b>27.68</b>	<b>27.68</b>
10 = 32,000Hz	10 = 200	Bypass	40.00	<b>40.00</b>	<b>40.00</b>
11 = 31,968Hz	10 = 199.8	Bypass	39.96	<b>39.96</b>	<b>39.96</b>

**Note:** Combinations shown in grey are unsupported and will be internally mapped to the default settings shown.

**CNFG\_BMUX(0x17)**

CNFG\_BMUX is a read/write register which configures the operation, settings, and functionality of the input multiplexer associated with the BioZ channel.

**Table 34. CNFG\_BMUX (0x17) Register Map**

REG	NAME	R/W	23/15/7	22/14/6	21/13/5	20/12/4	19/11/3	18/10/2	17/9/1	16/8/0
0x17	CNFG_BMUX	R/W	x	x	BMUX_OPENP	BMUX_OPENN	BMUX_CALP_SEL[1:0]		BMUX_CALN_SEL[1:0]	
			x	x	BMUX_CG_MODE[1:0]		BMUX_EN_BIST	BMUX_RNOM[2:0]		
			x	BMUX_RMOD[2:0]			x	x	BMUX_FBIST[1:0]	

**Table 35. CNFG\_BMUX (0x17) Register Functionality**

INDEX	NAME	DEFAULT	FUNCTION
D[21]	BMUX_OPENP	1	Open the BIP Input Switch (most often used for testing and calibration) 0 = BIP is internally connected to the BioZ channel 1 = BIP is internally isolated from the BioZ channel
D[20]	BMUX_OPENN	1	Open the BIN Input Switch (most often used for testing and calibration) 0 = BIN is internally connected to the BioZ channel 1 = BIN is internally isolated from the BioZ channel
D[19:18]	BMUX_CALP_SEL[1:0]	00	BIP Calibration Selection 00 = No calibration signal applied 01 = Input is connected to VMID 10 = Input is connected to VCALP (only available if CAL_EN_VCAL=1) 11 = Input is connected to VCALN (only available if CAL_EN_VCAL=1)
D[17:16]	BMUX_CALN_SEL[1:0]	00	BIN Calibration Selection 00 = No calibration signal applied 01 = Input is connected to VMID 10 = Input is connected to VCALP (only available if CAL_EN_VCAL=1) 11 = Input is connected to VCALN (only available if CAL_EN_VCAL=1)
D[13:12]	BMUX_CG_MODE[1:0]	00	BioZ Current Generator Mode Selection. Set to 00 if using low current range (BIOZ_HI_LOB = 1). 00 = Unchopped Sources with Low Pass Filter (higher noise, excellent 50/60Hz rejection, recommended for ECG, BioZ applications) 01 = Chopped Sources without Low Pass Filter (low noise, no 50/60Hz rejection, recommended for BioZ applications with digital LPF, possibly battery powered ECG, BioZ applications) 10 = Chopped Sources with Low Pass Filter (low noise, excellent 50/60Hz rejection) 11 = Chopped Sources with Resistive CM Setting (Not recommended to be used for drive currents >32µA) (low noise, excellent 50/60Hz rejection, lower input impedance)

**Table 35. CNFG\_BMUX (0x17) Register Functionality (continued)**

INDEX	NAME	DEFAULT	FUNCTION
D[11]	BMUX_EN_BIST	0	BioZ Modulated Resistance Built-In-Self-Test (RMOD BIST) Mode Enable 0 = RMOD BIST Disabled 1 = RMOD BIST Enabled Note: Available only when CNFG_CAL EN_VCAL= 0 To avoid body interference, the BIP/N switches should be open in this mode. When enabled, the DRVP/N isolation switches are opened and the DRVP/N-to-BIP/N internal switches are engaged. Also, the lead bias resistors are applied to the BioZ inputs in 200MΩ mode.
D[10:8]	BMUX_RNOM[2:0]	000	BioZ RMOD BIST Nominal Resistance Selection. For higher resistance values, see BIOZ_CNFG_LC. See RMOD BIST Settings Table for details.
D[6:4]	BMUX_RMOD[2:0]	100	BioZ RMOD BIST Modulated Resistance Selection (See RMOD BIST Settings Table for details.) 000 = Modulated Resistance Value 0 001 = Modulated Resistance Value 1 010 = Modulated Resistance Value 2 011 = Reserved, Do Not Use 1xx = All SWMOD Switches Open - No Modulation (DC value = RNOM)
D[1:0]	BMUX_FBIST[1:0]	00	BioZ RMOD BIST Frequency Selection Calibration Source Frequency Selection (FCAL) 00 = $f_{MSTR}/2^{13}$ (Approximately 4 Hz) 01 = $f_{MSTR}/2^{15}$ (Approximately 1 Hz) 10 = $f_{MSTR}/2^{17}$ (Approximately 1/4 Hz) 11 = $f_{MSTR}/2^{19}$ (Approximately 1/16 Hz) Actual frequencies are determined by FMSTR selection (see CNFG_GEN for details), approximate frequencies are based on a 32,768 Hz clock (FMSTR[1:0]=00). All selections use 50% duty cycle.

**Table 36. CNFG\_BMUX (0x17) RMOD BIST Settings**

BMUX_RNOM[2:0]	BMUX_RMOD[2:0]	NOMINAL RESISTANCE (Ω)	MODULATED RESISTANCE (mΩ)
000	000	5000	2960.7
	001		980.6
	010		247.5
	1xx		Unmodulated
001	000	2500	740.4
	001		245.2
	010		61.9
	1xx		Unmodulated
010	000	1667	329.1
	001		109.0
	010		27.5
	1xx		Unmodulated

**Table 36. CNFG\_BMUX (0x17) RMOD BIST Settings (continued)**

BMUX_RNOM[2:0] AND SWNOM SWITCHES ENGAGED	BMUX_RMOD[2:0]	NOMINAL RESISTANCE ( $\Omega$ )	MODULATED RESISTANCE (m $\Omega$ )
011	000 001 1xx	1250	185.1 61.3 Unmodulated
100	000 001 1xx	1000	118.5 39.2 Unmodulated
101	000 001 1xx	833	82.3 27.2 Unmodulated
110	000 001 1xx	714	60.5 20.0 Unmodulated
111	000 001 1xx	625	46.3 15.3 Unmodulated

**CNFG\_BIOZ(0x18)**

CNFG\_BIOZ is a read/write register which configures the operation, settings, and function of the BioZ channel, including the associated modulated current generator. Anytime a change to CNFG\_BIOZ is made, there may be discontinuities in the BioZ record and possibly changes to the size of the time steps recorded in the BioZ FIFO. The SYNCH command can be used to restore internal synchronization resulting from configuration changes.

**Table 37. CNFG\_BIOZ (0x18) Register Map**

REG	NAME	R/W	23/15/7	22/14/6	21/13/5	20/12/4	19/11/3	18/10/2	17/9/1	16/8/0	
0x18	CNFG_BioZ	R/W	BIOZ_RATE	BIOZ_AHPF[2:0]			EXT_RBIAS	LN_BIOZ	BIOZ_GAIN[1:0]		
			BIOZ_DHPF[1:0]		BIOZ_DLPF[1:0]		BIOZ_FCGEN[3:0]				
			BIOZ_CGMON	BIOZ_CGMAG[2:0]			BIOZ_PHOFF[3:0]				



**Table 38. CNFG\_BIOZ (0x18) Register Functionality**

INDEX	NAME	DEFAULT	FUNCTION
D[23]	BIOZ_RATE	0	BioZ Data Rate (also dependent on FMSTR selection, see CNFG_GEN):
			FMSTR = 00: $f_{MSTR} = 32,768\text{Hz}$ (512Hz ECG/BioZ progressions) 0 = 64sps 1 = 32sps
			FMSTR = 01: $f_{MSTR} = 32,000\text{Hz}$ (500Hz ECG/BioZ progressions) 0 = 62.50sps 1 = 31.25sps
			FMSTR = 10: $f_{MSTR} = 32,000\text{ Hz}$ (200Hz ECG/BioZ progressions) 0 = 50sps 1 = 25sps
			FMSTR = 11: $f_{MSTR} = 31,968\text{ Hz}$ (199.8Hz ECG/BioZ progressions) 0 = 49.95sps 1 = 24.98sps
D[22:20]	BIOZ_AHPF[2:0]	010	BioZ Channel Analog High-Pass Filter Cutoff Frequency and Bypass 000 = 60Hz 001 = 150Hz 010 = 500Hz 011 = 1000Hz 100 = 2000Hz 101 = 4000Hz 11x = Bypass AHPF
D[19]	EXT_RBIAS	0	External Resistor Bias Enable 0 = Internal Bias Generator used 1 = External Bias Generator used  Note: Use of the external resistor bias will improve the temperature coefficient of all biases within the product, but the main benefit is improved control of BioZ current generator magnitude. If enabled, the user must include the required external resistor between R <sub>BIAS</sub> and GND, and the temperature coefficient achieved will be determined by the combined performance of the internal bandgap and the external resistor.
D[18]	LN_BIOZ	0	BioZ Channel Instrumentation Amplifier (INA) Power Mode 0 = BioZ INA is in low power mode 1 = BioZ INA is in low noise mode
D[17:16]	BIOZ_GAIN[1:0]	00	BioZ Channel Gain Setting 00 = 10V/V 01 = 20V/V 10 = 40V/V 11 = 80V/V
D[15:14]	BIOZ_DHPF[1:0]	00	BioZ Channel Digital High-Pass Filter Cutoff Frequency 00 = Bypass (DC) 01 = 0.05Hz 1x = 0.50Hz

Table 38. CNFG\_BIOZ (0x18) Register Functionality (continued)

INDEX	NAME	DEFAULT	FUNCTION
D[13:12]	BIOZ_DLPF[1:0]	01	<p>BioZ Channel Digital Low-Pass Filter Cutoff Frequency</p> <p>00 = Bypass (Decimation only, no FIR filter)</p> <p>01 = 4Hz</p> <p>10 = 8Hz</p> <p>11 = 16Hz (Available for 64, 62.5, 50, and 49.95sps BioZ Rate selections only)</p> <p>Note: See Table 39 below. If an unsupported DLPF setting is specified, the 4Hz setting (BIOZ_DLPF[1:0] = 01) will be used internally; the CNFG_BIOZ register will continue to hold the value as written, but return the effective internal value when read back.</p>
D[11:8]	BIOZ_FCGEN[3:0]	1000	<p>BioZ Current Generator Modulation Frequency</p> <p>0000 = <math>4 \cdot f_{MSTR}</math> (approximately 128000Hz) 1000 = <math>f_{MSTR}/64</math> (approximately 500Hz)</p> <p>0001 <math>\approx 2 \cdot f_{MSTR}</math> (approximately 80000Hz) 1001 = <math>f_{MSTR}/128</math> (approximately 250Hz)</p> <p>0010 <math>\approx f_{MSTR}</math> (approximately 40000Hz) 101x = <math>f_{MSTR}/256</math> (approximately 125Hz)</p> <p>0011 <math>\approx f_{MSTR}/2</math> (approximately 18000Hz) 11xx = <math>f_{MSTR}/256</math> (approximately 125Hz)</p> <p>0100 = <math>f_{MSTR}/4</math> (approximately 8000Hz)</p> <p>0101 = <math>f_{MSTR}/8</math> (approximately 4000Hz)</p> <p>0110 = <math>f_{MSTR}/16</math> (approximately 2000Hz)</p> <p>0111 = <math>f_{MSTR}/32</math> (approximately 1000Hz)</p> <p>Actual frequencies determined by FMSTR selection, see CNFG_GEN register and table below for details. Frequencies expected between approximately 16kHz and approximately 64kHz are offset to approximately 18kHz to approximately 80kHz to reduce ECG/BioZ channel crosstalk.</p>
D[7]	BIOZ_CGMON	0	<p>BioZ Current Generator Monitor</p> <p>0 = Current Generator Monitors disabled</p> <p>1 = Current Generator Monitors enabled, requires active BioZ channel and Current Generators. Enables BCGMON interrupt and status bit behavior. Monitors current source compliance levels, useful in detecting DRVP/DRVN lead off conditions with 4 electrode BioZ applications.</p>
D[6:4]	BIOZ_CGMAG[2:0]	000	<p>BioZ Current Generator Magnitude. Must be set to 001 if using low current range (BIOZ_HI_LOB = 0).</p> <p>000 = Off (DRVP and DRVN floating, Current Generators Off)</p> <p>001 = 8<math>\mu</math>A</p> <p>010 = 16<math>\mu</math>A</p> <p>011 = 32<math>\mu</math>A</p> <p>100 = 48<math>\mu</math>A</p> <p>101 = 64<math>\mu</math>A</p> <p>110 = 80<math>\mu</math>A</p> <p>111 = 96<math>\mu</math>A</p> <p>See Table 40 and 41 below for a list of allowed BIOZ_CGMAG settings vs. FCGEN selections.</p>
D[3:0]	BIOZ_PHOFF[3:0]	0000	<p>BioZ Current Generator Modulation Phase Offset</p> <p>Phase Resolution and Offset depends on BIOZ_FCGEN setting:</p> <p>BIOZ_FCGEN[3:0] <math>\geq</math> 0010: Phase Offset = BIOZ_PHOFF[3:0]*11.25° (0 to 168.75°)</p> <p>BIOZ_FCGEN[3:0] = 0001: Phase Offset = BIOZ_PHOFF[3:1]*22.50° (0 to 157.50°)</p> <p>BIOZ_FCGEN[3:0] = 0000: Phase Offset = BIOZ_PHOFF[3:2]*45.00° (0 to 135.00°)</p>

**Table 39. Supported BIOZ\_RATE and BIOZ\_DLPF Options**

CNFG_GEN FMSTR[1:0]	BIOZ_RATE Sample Rate	BIOZ_DLPF[1:0] / Digital LPF Cut Off			
		00	01	10	11
00 = 32,768Hz	0 = 64sps	Bypass	4.096Hz	8.192Hz	16.384Hz
	1 = 32sps				4.096Hz
01 = 32,000Hz	0 = 62.5sps	Bypass	4.0Hz	8.0Hz	16.0Hz
	1 = 31.25sps				4.0Hz
10 = 32,000Hz	0 = 50sps	Bypass	4.0Hz	8.0Hz	16.0Hz
	1 = 25sps				4.0Hz
11 = 31,968Hz	0 = 49.95sps	Bypass	3.996Hz	7.992Hz	15.984Hz
	1 = 25.98sps				3.996Hz

**Note:** Combinations shown in grey are unsupported and will be internally mapped to the default settings shown.

**Table 40. Actual BioZ Current Generator Modulator Frequencies vs.  
FMSTR[1:0] Selection**

BIOZ_FCGEN[3:0]	BioZ Current Generator Modulation Frequency (Hz)			
	FMSTR[1:0] = 00 $f_{MSTR} = 32,768\text{Hz}$	FMSTR[1:0] = 01 $f_{MSTR} = 32,000\text{Hz}$	FMSTR[1:0] = 10 $f_{MSTR} = 32,000\text{Hz}$	FMSTR[1:0] = 11 $f_{MSTR} = 31,968\text{Hz}$
0000	131,072	128,000	128,000	127,872
0001	81,920	80,000	80,000	81,920
0010	40,960	40,000	40,000	40,960
0011	18,204	17,780	17,780	18,204
0100	8,192	8,000	8,000	7,992
0101	4,096	4,000	4,000	3,996
0110	2,048	2,000	2,000	1,998
0111	1,024	1,000	1,000	999
1000	512	500	500	500
1001	256	250	250	250
101x, 11xx	128	125	125	125

**Note:** Shaded selections are intentionally offset to improve ECG/BioZ system crosstalk.

**Table 41. Allowed CGMAG Option vs. FCGEN Selections**

FCGEN[3:0]	APPROXIMATE CURRENT GENERATOR MODULATION FREQUENCY (Hz)	CGMAG[2:0] OPTIONS ALLOWED	CURRENT GENERATOR MAGNITUDE OPTIONS ALLOWED ( $\mu\text{A}_{\text{p-p}}$ )
0000	12,8000	All	All
0001	80,000		
0010	40,000		
0011	18,000		
0100	8,000	All except 111	All except 96
0101	4,000	000, 001, 010, 011	Off, 8, 16, 32
0110	2,000	000, 001, 010	Off, 8, 16
0111	1,000	000, 001	Off, 8
1000	500		
1001	250		
101x, 11xx	125		

**CNFG\_BIOZ\_LC (0x1A) Register**

CNFG\_BIOZ\_LC is a read/write register that configures the operation, settings, and function of the BioZ channel low current ranges, including built-in self-test resistance. Use in conjunction with CNFG\_BIOZ (0x18) to set the BioZ drive current parameters. Any time a change to CNFG\_BIOZ is made, there might be discontinuities in the BioZ record and possibly changes to the size of the time steps recorded in the BioZ FIFO. The SYNCH command can be used to restore internal synchronization resulting from configuration changes.

**Table 42. CNFG\_BIOZ\_LC (0x1A) Register Map**

REG	NAME	R/W	23/15/7	22/14/6	21/13/5	20/12/4	19/11/3	18/10/2	17/9/1	16/8/0
0x1A	CNFG_BIOZ_LC	R/W	BIOZ_HI_LOB	x	x	x	BIOZ_LC2X	x		
			x	EN_BISTR	BISTR[1:0]		x	x	x	x
			BIOZ_CMFB_LC[3:0]				BIOZ_CMAG_LC[3:0]			

**Table 43. CNFG\_BIOZ\_LC (0x1A) Register Functionality**

INDEX	NAME	DEFAULT	FUNCTION																								
D[23]	BIOZ_HI_LOB	0	Select between BioZ high or low drive current ranges 0 = BioZ drive current is Low (55nA to 1100nA) 1 = BioZ drive current is High (8µA to 96µA)																								
D[19]	BIOZ_LC2X	0	Select between 1X and 2X subranges for the low current range 0 = BIOZ Low drive current is 1X (55nA to 550nA) 1 = BIOZ Low drive current is 2X (550nA to 1100nA)																								
D[14]	EN_BISTR	0	Built-in Self-Test Resistor Enable for High Resistance Values 0 = Disable built-in self-test resistor 1 = Enable built-in self-test resistor																								
D[13:12]	BISTR[1:0]	00	Built-in Self-Test Resistor Value Selection 00 = 27 kΩ 01 = 108 kΩ 10 = 487 kΩ 11 = 1029 kΩ																								
D[7:4]	BIOZ_CMRES[3:0]	0101	Common-mode Feedback Resistance for BioZ Low Current Generator Value Selection Set to approximately: CMRES in MΩ = 5 / (drive current in µA) 0000 = OFF 0001 = 320MΩ 0011 = 160MΩ 0111 = 80MΩ 1000 = 40MΩ 1001 = 20MΩ 1011 = 10MΩ 1111 = 5MΩ All other codes are invalid.																								
D[3:0]	BIOZ_CMAG_LC[3:0]	0101	BioZ Low Current Magnitude Selection <table style="margin-left: auto; margin-right: auto;"> <thead> <tr> <th></th> <th>LC2X = 0</th> <th>LC2X = 1</th> </tr> </thead> <tbody> <tr> <td>0000 =</td> <td>0</td> <td>0</td> </tr> <tr> <td>0001 =</td> <td>55nA</td> <td>110nA</td> </tr> <tr> <td>0010 =</td> <td>110nA</td> <td>220nA</td> </tr> <tr> <td>0011 =</td> <td>220nA</td> <td>440nA</td> </tr> <tr> <td>0100 =</td> <td>330nA</td> <td>660nA</td> </tr> <tr> <td>0101 =</td> <td>440nA</td> <td>880nA</td> </tr> <tr> <td>0110 =</td> <td>550nA</td> <td>1100nA</td> </tr> </tbody> </table> All other codes are invalid.		LC2X = 0	LC2X = 1	0000 =	0	0	0001 =	55nA	110nA	0010 =	110nA	220nA	0011 =	220nA	440nA	0100 =	330nA	660nA	0101 =	440nA	880nA	0110 =	550nA	1100nA
	LC2X = 0	LC2X = 1																									
0000 =	0	0																									
0001 =	55nA	110nA																									
0010 =	110nA	220nA																									
0011 =	220nA	440nA																									
0100 =	330nA	660nA																									
0101 =	440nA	880nA																									
0110 =	550nA	1100nA																									

**CNFG\_RTOR1 and CNFG\_RTOR2 (0x1D and 0x1E)**

CNFG\_RTOR is a two-part read/write register that configures the operation, settings, and function of the R-to-R heart rate detection block. The first register contains algorithmic voltage gain and threshold parameters, the second contains algorithmic timing parameters.

**Table 44. CNFG\_RTOR1 and CNFG\_RTOR2 (0x1D and 0x1E) Register Maps**

REG	NAME	R/W	23/15/7	22/14/6	21/13/5	20/12/4	19/11/3	18/10/2	17/9/1	16/8/0
0x1D	CNFG_RTOR1	R/W	WNDW[3:0]				RGAIN[3:0]			
			EN_RTOR	x	PAVG[1:0]		PTSF[3:0]			
			x	x	x	x	x	x	x	x
0x1E	CNFG_RTOR2	R/W	x	x	HOFF[5:0]					
			x	x	RAVG[1:0]		x	RHSF[2:0]		
			x	x	x	x	x	x	x	x

**Table 45. CNFG\_RTOR1 (0x1D) Register Functionality**

INDEX	NAME	DEFAULT	FUNCTION
<b>CNFG_RTOR1 (0x1D)</b>			
D[23:20]	WNDW[3:0]	0011	<p>This is the width of the averaging window, which adjusts the algorithm sensitivity to the width of the QRS complex.</p> <p>R-to-R Window Averaging (Window Width = <math>WNDW[3:0] \times 8ms</math>)</p> <p>0000 = 6 x RTOR_RES                      0001 = 8 x RTOR_RES                      0010 = 10 x RTOR_RES                      0011 = 12 x RTOR_RES (default = 96ms)                      0100 = 14 x RTOR_RES                      0101 = 16 x RTOR_RES                      0110 = 18 x RTOR_RES                      0111 = 20 x RTOR_RES                      1000 = 22 x RTOR_RES                      1001 = 24 x RTOR_RES                      1010 = 26 x RTOR_RES                      1011 = 28 x RTOR_RES                      1100 = Reserved. Do not use.                      1101 = Reserved. Do not use.                      1110 = Reserved. Do not use.                      1111 = Reserved. Do not use.</p> <p>The value of RTOR_RES is approximately 8ms, see Table 26.</p>
D[19:16]	RGAIN[3:0]	1111	<p>R-to-R Gain (where <math>Gain = 2^{RGAIN[3:0]}</math>, plus an auto-scale option). This is used to maximize the dynamic range of the algorithm.</p> <p>0000 = 1                    1000 = 256                      0001 = 2                    1001 = 512                      0010 = 4                    1010 = 1024                      0011 = 8                    1011 = 2048                      0100 = 16                   1100 = 4096                      0101 = 32                   1101 = 8192                      0110 = 64                   1110 = 16384                      0111 = 128                  1111 = Auto-Scale (default)</p> <p>In Auto-Scale mode, the initial gain is set to 64.</p>

**Table 45. CNFG\_RTOR1 (0x1D) Register Functionality (continued)**

INDEX	NAME	DEFAULT	FUNCTION
D[15]	EN_RTOR	0	ECG R-to-R Detection Enable 0 = R-to-R Detection disabled 1 = R-to-R Detection enabled if EN_ECG is also enabled.
D[13:12]	PAVG[1:0]	10	R-to-R Peak Averaging Weight Factor This is the weighting factor for the current R-to-R peak observation vs. past peak observations when determining peak thresholds. Lower numbers weight current peaks more heavily. 00 = 2 01 = 4 10 = 8 (default) 11 = 16 $Peak\_Average(n) = [Peak(n) + (PAVG-1) \times Peak\_Average(n-1)] / PAVG.$
D[11:8]	PTSF[3:0]	0011	R-to-R Peak Threshold Scaling Factor This is the fraction of the Peak Average value used in the Threshold computation. Values of 1/16 to 16/16 are selected by (PTSF[3:0]+1)/16, default is 4/16.

**Table 46. CNFG\_RTOR2 (0x1E) Register Functionality**

CNFG_RTOR2 (0x1E)			
D [21:16]	HOFF[5:0]	10_0000	R-to-R Minimum Hold Off This sets the absolute minimum interval used for the static portion of the Hold Off criteria. Values of 0 to 63 are supported, default is 32 $t_{HOLD\_OFF\_MIN} = HOFF[5:0] \times t_{RTOR}$ , where $t_{RTOR}$ is approximately 8ms, as determined by FMSTR[1:0] in the CNFG_GEN register. (representing approximately ¼ second). The R-to-R Hold Off qualification interval is $t_{Hold\_Off} = MAX(t_{Hold\_Off\_Min}, t_{Hold\_Off\_Dyn})$ (see below).
D[13:12]	RAVG[1:0]	10	R-to-R Interval Averaging Weight Factor This is the weighting factor for the current R-to-R interval observation vs. the past interval observations when determining dynamic holdoff criteria. Lower numbers weight current intervals more heavily. 00 = 2 01 = 4 10 = 8 (default) 11 = 16 $Interval\_Average(n) = [Interval(n) + (RAVG-1) \times Interval\_Average(n-1)] / RAVG.$
D[10:8]	RHSF[2:0]	100	R-to-R Interval Hold Off Scaling Factor This is the fraction of the R-to-R average interval used for the dynamic portion of the holdoff criteria ( $t_{HOLD\_OFFDYN}$ ). Values of 0/8 to 7/8 are selected by RTOR_RHSF[3:0]/8, default is 4/8. If 000 (0/8) is selected, then no dynamic factor is used and the holdoff criteria is determined by HOFF[5:0] only (see above).

**FIFO Memory Description**

The device provides read only FIFO memory for ECG, and BioZ information. A single memory register is also supported for heart rate detection output data (R-to-R). The operation of these FIFO memories and registers is detailed in the following sections.

Table 47 summarizes the method of access and data structure within the FIFO memory.

**ECG FIFO Memory (32 Words x 24 Bits)**

The ECG FIFO memory is a standard circular FIFO consisting of 32 words, each with 24 bits of information.

The ECG FIFO is independently managed by internal read and write pointers. The read pointer is updated in response to the 32nd SCLK rising edge in a normal mode read back transaction and on the (32 + n x 24)th SCLK rising edge(s) in a burst mode transaction where n = 0 to up to 31. Once a FIFO sample is marked as read, it cannot be accessed again.

The write pointer is governed internally. To aide data management and reduce  $\mu\text{C}$  overhead, the device provides a user-programmable ECG FIFO Interrupt Threshold (EFIT[4:0]) governing the ECG interrupt bit (EINT). This threshold can be programmed with values from 1 to 32, representing the number of unread ECG FIFO entries required before the EINT bit will be asserted, alerting the  $\mu\text{C}$  that there is a significant amount of data in the ECG FIFO ready for read back (see MNGR\_INT (0x04) for details).

Do not read beyond the last valid FIFO word to prevent possible data corruption.

If the write pointer ever traverses the entire FIFO array and catches up to the read pointer (due to failure of the  $\mu\text{C}$  to read/maintain FIFO data), a FIFO overflow will occur and data will be corrupted. The EOVF STATUS and tag bits will indicate this condition and the FIFO should be cleared before continuing measurements using either a SYNCH or FIFO\_RST command—note overflow events will result in the loss of samples and thus timing information, so these conditions should not occur in well-designed applications.

**Table 47. FIFO Memory Access and Data Structure Summary**

REG	FIFO AND MODE	DATA STRUCTURE (D[23:0])																							
		23	22	21	20	19	18	17	16	15	14	13	12	11	10	9	8	7	6	5	4	3	2	1	0
0x20	ECG Burst	ECG Sample Voltage Data [17:0]																	ETAG [2:0]		x				
0x21	ECG	ECG Sample Voltage Data [17:0]																	ETAG [2:0]		x				
		23	22	21	20	19	18	17	16	15	14	13	12	11	10	9	8	7	6	5	4	3	2	1	0
0x22	BioZ Burst	BioZ Sample Voltage Data [19:0]																	0		BTAG [2:0]				
0x23	BioZ	BioZ Sample Voltage Data [19:0]																	0		BTAG [2:0]				
		23	22	21	20	19	18	17	16	15	14	13	12	11	10	9	8	7	6	5	4	3	2	1	0
0x25	RTOR	RTOR Interval Timing Data [13:0]													0 0 0 0 0 0 0 0 0 0 0 0 0										



### ECG FIFO Data Structure

The data portion of the word contains the 18-bit ECG voltage information measured at the requested sample rate in left justified two's complement format. The remaining six bits of data hold important data tagging information (see details in [Table 48](#) and [Table 49](#)).

After converting the data portion of the sample to signed magnitude format, the ECG input voltage is calculated by the following equation:

$$V_{\text{ECG}} \text{ (mV)} = \text{ADC} \times V_{\text{REF}} / (2^{17} \times \text{ECG\_GAIN})$$

where:

ADC = ADC counts in signed magnitude format,  $V_{\text{REF}} = 1000\text{mV}$  (typ) (refer to the [Electrical Characteristics](#) section), and ECG\_GAIN = 20V/V, 40V/V, 80V/V, or 160V/V, set in CNFG\_ECG (0x15).

### ECG Data Tags (ETAG)

Three bits in the sample record are used as an ECG data tag (ETAG[2:0] = D[5:3]). This section outlines the meaning of the various data tags used in the ECG FIFO

and recommended handling within the continuous ECG record.

**VALID:** ETAG = 000 indicates that ECG data for this sample represents both a valid voltage and time step in the ECG record.

**FAST:** ETAG = 001 indicates that ECG data for this sample was taken in the FAST settling mode and that the voltage information in the sample should be treated as transient and invalid. Note that while the voltage data is invalid, samples of this type do represent valid time steps in the ECG record.

**VALID EOF:** ETAG = 010 indicates that ECG data for this sample represents both a valid voltage and time step in the ECG record, and that this is the last sample currently available in the ECG FIFO (End-of-File, EOF). The  $\mu\text{C}$  should wait until further samples are available before requesting more data from the ECG FIFO.

**FAST EOF:** ETAG = 011 indicates that ECG data for this sample was taken in the FAST settling mode and that the voltage information in the sample should be treated as transient and invalid. Note that while the voltage data is

**Table 48. ECG FIFO - ECG Data Tags (ETAG[2:0] = D[5:3])**

ETAG [2:0]	MEANING	DETAILED DESCRIPTION	RECOMMENDED USER ACTION	DATA VALID	TIME VALID
000	Valid Sample	This is a valid FIFO sample.	Log sample into ECG record and increment the time step. Continue to gather data from the ECG FIFO.	Yes	Yes
001	Fast Mode Sample	This sample was taken while the ECG channel was in a FAST recovery mode. The voltage information is not valid, but the sample represents a valid time step.	Discard, note, or post-process this voltage sample, but increment the time base. Continue to gather data from the ECG FIFO.	No	Yes
010	Last Valid Sample (EOF)	This is a valid FIFO sample, but this is the last sample currently available in the FIFO (End of File indicator).	Log sample into ECG record and increment the time step. Suspend read back operations on the ECG FIFO until more samples are available.	Yes	Yes
011	Last Fast Mode Sample (EOF)	See above (ETAG=001), but in addition, this is the last sample currently available in the FIFO (End of File indicator).	Discard, note, or post-process this voltage sample, but increment the time base. Suspend read back operations on the ECG FIFO until more samples are available.	No	Yes
10x	Unused			--	--
110	FIFO Empty (Exception)	This is an invalid sample provided in response to an SPI request to read an empty FIFO.	Discard this sample, without incrementing the time base. Suspend read back operations on this FIFO until more samples are available.	No	No
111	FIFO Overflow (Exception)	The FIFO has been allowed to overflow – the data is corrupted.	Issue a FIFO_RST command to clear the FIFOs or re-SYNCH if necessary. Note the corresponding halt and resumption in ECG/BioZ time/voltage records.	No	No

invalid, samples of this type do represent valid time steps in the ECG record. In addition, this is the last sample currently available in the ECG FIFO (End-of-File, EOF). The  $\mu\text{C}$  should wait until further samples are available before requesting more data from the ECG FIFO.

**EMPTY:** ETAG = 110 is appended to any requested read back data from an empty ECG FIFO. The presence of this tag alerts the user that this FIFO data does not represent a valid sample or time step. Note that if handled properly by the  $\mu\text{C}$ , an occurrence of an empty tag will not compromise the integrity of a continuous ECG record – this tag only indicates that the read back request was either premature or unnecessary.

**OVERFLOW:** ETAG = 111 indicates that the ECG FIFO has overflowed and that there are interruptions or missing data in the sample records. The ECG Overflow (EOVF) bit is also included in the STATUS register. A FIFO\_RESET is required to resolve this situation, effectively clearing the FIFO so that valid sampling going forward is assured. Depending on the application, it may also be necessary to resynchronize the MAX30001G internal channel operations to move forward with valid recordings, the SYNCH command can perform this function while also resetting the FIFO memories.

### BioZ FIFO Memory (8 Words x 24 Bits)

The BioZ FIFO memory is a standard circular FIFO consisting of 8 words, each with 24 bits of information. The BioZ FIFO is independently managed by internal read and write pointers. The read pointer is updated in response to the 32nd SCLK rising edge in a normal mode read back transaction and on the  $(32 + n \times 24)$ th SCLK rising edge(s) in a burst mode transaction where  $n = 0$  to up to 31. Once a FIFO sample is marked as read, it cannot be accessed again.

The write pointer is governed internally. To aide data management and reduce  $\mu\text{C}$  overhead, the device provides a user-programmable BioZ FIFO Interrupt Threshold

(BFIT[2:0]) governing the BioZ Interrupt bit (BINT). This threshold can be programmed with values from 1 to 8, representing the number of unread BioZ FIFO entries required before the BINT bit will be asserted, alerting the  $\mu\text{C}$  that there is a significant amount of data in the BioZ FIFO ready for read back (see MNGR\_INT (0x04) for details).

If the write pointer ever traverses the entire FIFO array and catches up to the read pointer (due to failure of the  $\mu\text{C}$  to read/maintain FIFO data), a FIFO overflow will occur and data will be corrupted. The BOVF STATUS and tag bits will indicate this condition and the FIFO should be cleared before continuing measurements using either a SYNCH or FIFO\_RST command—note overflow events will result in the loss of samples and thus timing information, so these conditions should not occur in well-designed applications.

Do not read beyond the last valid FIFO word to prevent possible data corruption.

### BioZ FIFO Data Structure

The data portion of the word contains the 20-bit BioZ voltage information measured at the requested sample rate in left justified two's complement format. One bit is set to 0 and the remaining three bits of data hold important data tagging information (see details in [Table 49](#)).

After converting the data portion of the sample to signed magnitude format, BioZ is calculated by the following equation:

$$\text{BioZ } (\Omega) = \text{ADC} \times V_{\text{REF}} / (2^{19} \times \text{BIOZ\_CGMAG} \times \text{BIOZ\_GAIN})$$

where:

ADC = ADC counts in signed magnitude format,  $V_{\text{REF}} = 1\text{V}$  (typ) (refer to the [Electrical Characteristics](#) section), BIOZ\_CGMAG is  $50 \times 10^{-9}$  to  $96 \times 10^{-6}$  A, set by CNFG\_BIOZ and CNFG\_BIOZ\_LC and BIOZ\_GAIN = 10V/V, 20V/V, 40V/V, or 80V/V. BIOZ\_GAIN are set in CNFG\_BIOZ (0x18).

**Table 49. BioZ FIFO BioZ Data Tags (BTAG[2:0] = D[2:0])**

BTAG [2:0]	DESCRIPTION	RECOMMENDED USER ACTION	DATA VALID	TIME VALID
000	Valid Sample	Log sample into BioZ record and increment the time step. Continue to read data from the BioZ FIFO.	Yes	Yes
001	Over/Under Range Sample	Log sample into BioZ record and increment the time step. Determine if the data is valid or a lead off condition. Continue to read data from the BioZ FIFO.	?	Yes
010	Last Valid Sample (EOF)	Log sample into BioZ record and increment the time step. Suspend read of the BioZ FIFO until more samples are available.	Yes	Yes
011	Last Over/Under Range Sample (EOF)	Log sample into BioZ record and increment the time step. Determine if the data is valid or a lead off condition. Suspend read of the BioZ FIFO until more samples are available.	?	Yes
10x	Unused	–	–	–
110	FIFO Empty (exception)	Discard this sample without incrementing the time base. Suspend read of the BioZ FIFO until more samples are available.	No	No
111	FIFO Overflow (exception)	Discard this sample without incrementing the time base. Issue a FIFO_RST command to clear the FIFOs or re-SYNCH if necessary. Note the corresponding halt and resumption in all the FIFOs.	No	No

**BioZ Data Tags (BTAG)**

The final three bits in the sample are used as a data tag (BTAG[2:0] = D[2:0]) to assist in managing data transfers. The BTAG structure used is detailed below.

**VALID:** BTAG = 000 indicates that BioZ data for this sample represents both a valid voltage and time step in the BioZ record.

**OVER or UNDER RANGE:** BTAG = 001 indicates that BioZ data for this sample violated selected range thresholds (see MNGR\_DYN and CNFG\_GEN) and that the voltage information in the sample should be evaluated to see if it is valid or indicative of a leads-off condition. Note that while the voltage data may be invalid, samples of this type do represent valid time steps in the BioZ record.

**VALID EOF:** BTAG = 010 indicates that BioZ data for this sample represents both a valid voltage and time step in the BioZ record, and that this is the last sample currently available in the BioZ FIFO (End-of-File, EOF). The  $\mu$ C should wait until further samples are available before requesting more data from the BioZ FIFO.

**OVER or UNDER RANGE EOF:** BTAG = 011 indicates that BioZ data for this sample violated selected range thresholds (see MNGR\_DYN and CNFG\_GEN) and that the voltage information in the sample should be evaluated to see if it is valid or indicates a leads-off condition. Note

that while the voltage data may be invalid, samples of this type do represent valid time steps in the BioZ record. This is also the last sample currently available in the BioZ FIFO (End-of-File, EOF). The  $\mu$ C should wait until further samples are available before requesting more data from the BioZ FIFO.

**EMPTY:** BTAG = 110 is appended to any requested read back data from an empty BioZ FIFO. The presence of this tag alerts the user that this FIFO data does not represent a valid sample or time step. Note that if handled properly by the  $\mu$ C, an occurrence of an empty tag will not compromise the integrity of a continuous BioZ record – this tag only indicates that the read back request was either premature or unnecessary.

**OVERFLOW:** BTAG = 111 indicates that the BioZ FIFO has overflowed and that there are interruptions or missing data in the sample records. The BioZ Overflow (BOVF) bit is also included in the STATUS register. A FIFO\_RESET is required to resolve this situation, effectively clearing the FIFO so that valid sampling going forward is assured. Depending on the application, it may also be necessary to resynchronize the MAX30001G internal channel operations to move forward with valid recordings, the SYNCH command can perform this function while also resetting the FIFO memories.

### R-to-R Interval Memory Register (1 Word x 24 Bits)

The R-to-R Interval (RTOR) memory register is a single read-only register consisting of 14 bits of timing interval information, left justified (and 10 unused bits, set to zero).

The RTOR register stores the time interval between the last two R events, as identified by the R-to-R detection circuitry, which operates on the ECG output data. Each LSB in the RTOR register is approximately equal to 8ms (CNFG\_GEN for exact figures). The resulting 14-bit storage interval can thus be approximately 130 seconds in length, again depending on device settings.

Each time the R-to-R detector identifies a new R event, the RTOR register is updated, and the RRINT interrupt bit is asserted (see STATUS register for details).

Users wishing to log heart rate based on RTOR register data should set CLR\_RRINT equals 01 in the MNGR\_INT register. This will clear the RRINT interrupt bit after the RTOR register has been read back, preparing the device for identification of the next R-to-R interval.

Users wishing to log heart rate based on the time elapsed between RRINT assertions using the  $\mu\text{C}$  to keep track of the time base (and ignoring the RTOR register data) have two choices for interrupt management. If CLR\_RRINT equals 00 in the MNGR\_INT register, the RRINT interrupt bit will clear after each STATUS register read back, preparing the device for identification of the next R-to-R interval. If CLR\_RRINT equals 10 in the MNGR\_INT register, the RRINT interrupt bit will self-clear after each one full ECG data cycle has passed, preparing the device for identification of the next R-to-R interval (this mode is recommended only if using the INT2B as a dedicated heart rate indicator).

If CLR\_RRINT = 0x (interrupt mode) and the R-to-R detector reaches an overflow state after several minutes without detection of an R event, it will assert the RRINT term with a RTOR register value = 0x3FFF, indicating the overflow condition. This interrupt creates a time stamp, allowing the  $\mu\text{C}$  to keep track of the time interval between detected R events, even if the signal is lost for a prolonged amount of time. This is important if the RTOR register data is the sole source to keep track of the time base. In the event of an overflow, the RTOR register will be reset after being read back, allowing the  $\mu\text{C}$  to track multiple subsequent overflow conditions. RRINT is reset independently of the RTOR register by an appropriate read back operation as specified by the setting of CLR\_RRINT.

If CLR\_RRINT = 1x (indicator mode) and the R-to-R detector reaches an overflow state after several minutes

without detection of an R event, the counter will simply roll over, and the lack of the RRINT activity on the dedicated INT2B line will inform the  $\mu\text{C}$  that no R-to-R activity was detected. Generating an interrupt to keep track of the absolute time is not required in this case, as this mode will be used in a system where the  $\mu\text{C}$  is used to keep track of the time base.

## Applications Information

### External Filters

External filters are recommended in environments with high levels of EMI to improve noise rejection on the inputs. Select corner frequencies according to the requirements of the channel. The [Typical Application Circuits](#) show examples of input filters, but component values must be modified according to application requirements.

The differential ECG signal occupies frequencies from about 0.05Hz to 200Hz. For applications that require less detail such as fitness monitors, the corner frequency can be lowered to about 40Hz, trading noise immunity for ECG detail. Place the common mode corner frequency about a decade below the AM radio band (535kHz).

The BioZ filter depends on the drive frequency used in the application. Place the differential mode corner frequency several decades higher than the maximum drive frequency. Place the common mode corner frequency higher than the differential mode corner frequency, but lower than the AM radio band.

### Body Bias Electrode

Compliance with the common mode input range of the ECG and BioZ channels is achieved by using internal lead bias or by adding a third electrode to drive the body to  $V_{\text{CM}}$ . The body bias drive electrode improves performance in applications with high electrode impedance or high 50Hz/60Hz coupling. Using  $V_{\text{CM}}$  drive also improves the input impedance because internal lead bias is disabled.

### IEC 60601-2-47 Compliance

IEC 60601-2-47:2012 concerns the basic safety and essential performance of AMBULATORY ELECTROCARDIOGRAPHIC SYSTEMS and the MAX30001G can be used in such systems and be compliant. The MAX30001G has been tested according to the clauses and subclauses that pertain to the analog front end and A/D conversion portions of such systems. With proper system design, a system including the MAX30001G can be certified to the standard.

Typical Application Circuits

Two-Electrode ECG and Respiration Monitor Typical Application Circuit

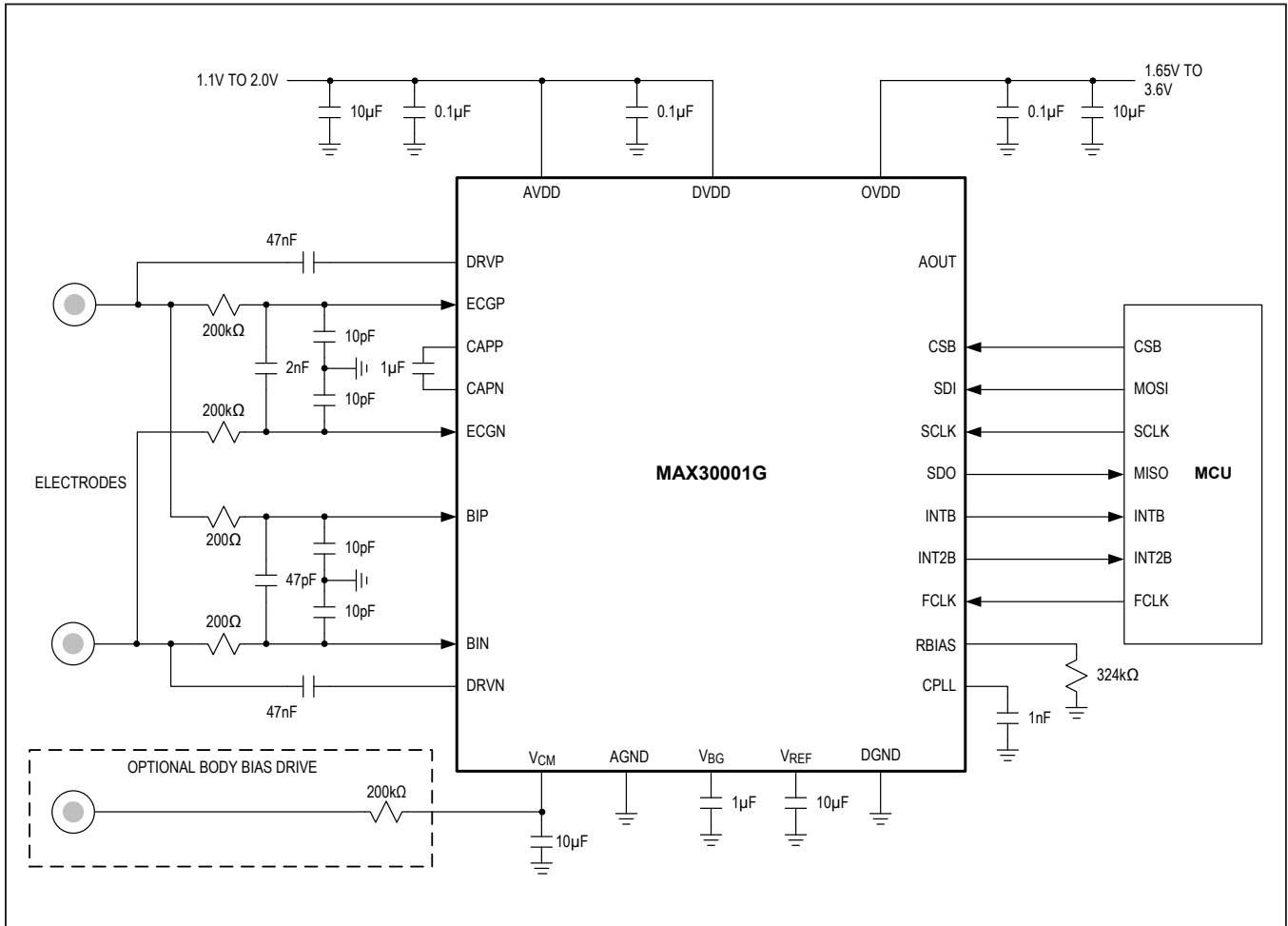

Typical Application Circuits (continued)

Four-Electrode ECG and Respiration Monitor Typical Application Circuit

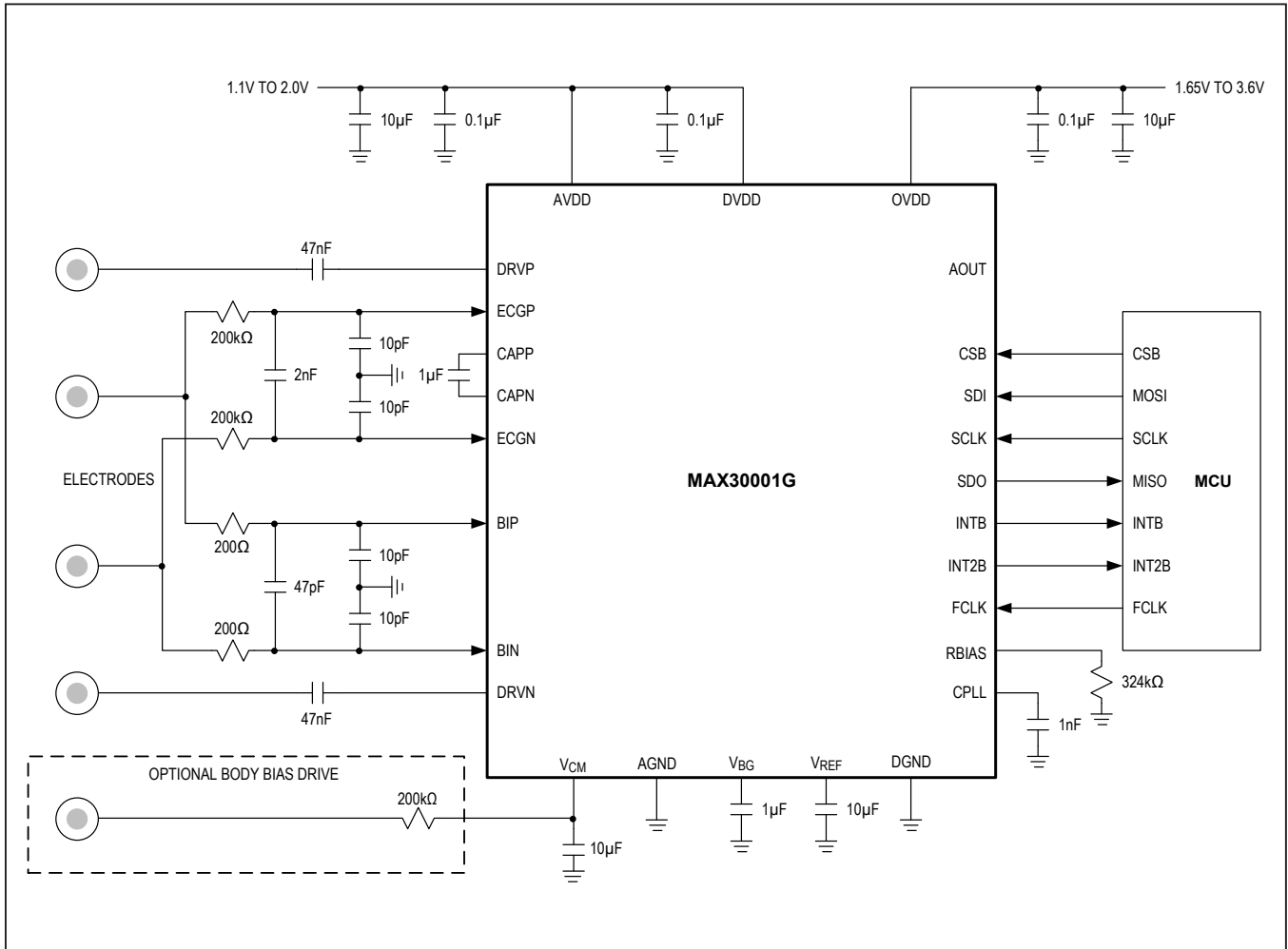

**Application Diagrams**

See [Figure 17](#) for an example of a clinical application for monitoring ECG and respiration using just two electrodes and with optional shared defibrillation protection circuitry. The electrode models are shown to illustrate the electrical characteristics of the physical electrodes.

**Four Electrode ECG and Respiration Monitoring Application**

See [Figure 18](#) for an example of a clinical application for monitoring ECG and respiration using four electrodes and with optional defibrillation protection circuitry. The electrode models are shown to illustrate the electrical characteristics of the physical electrodes.

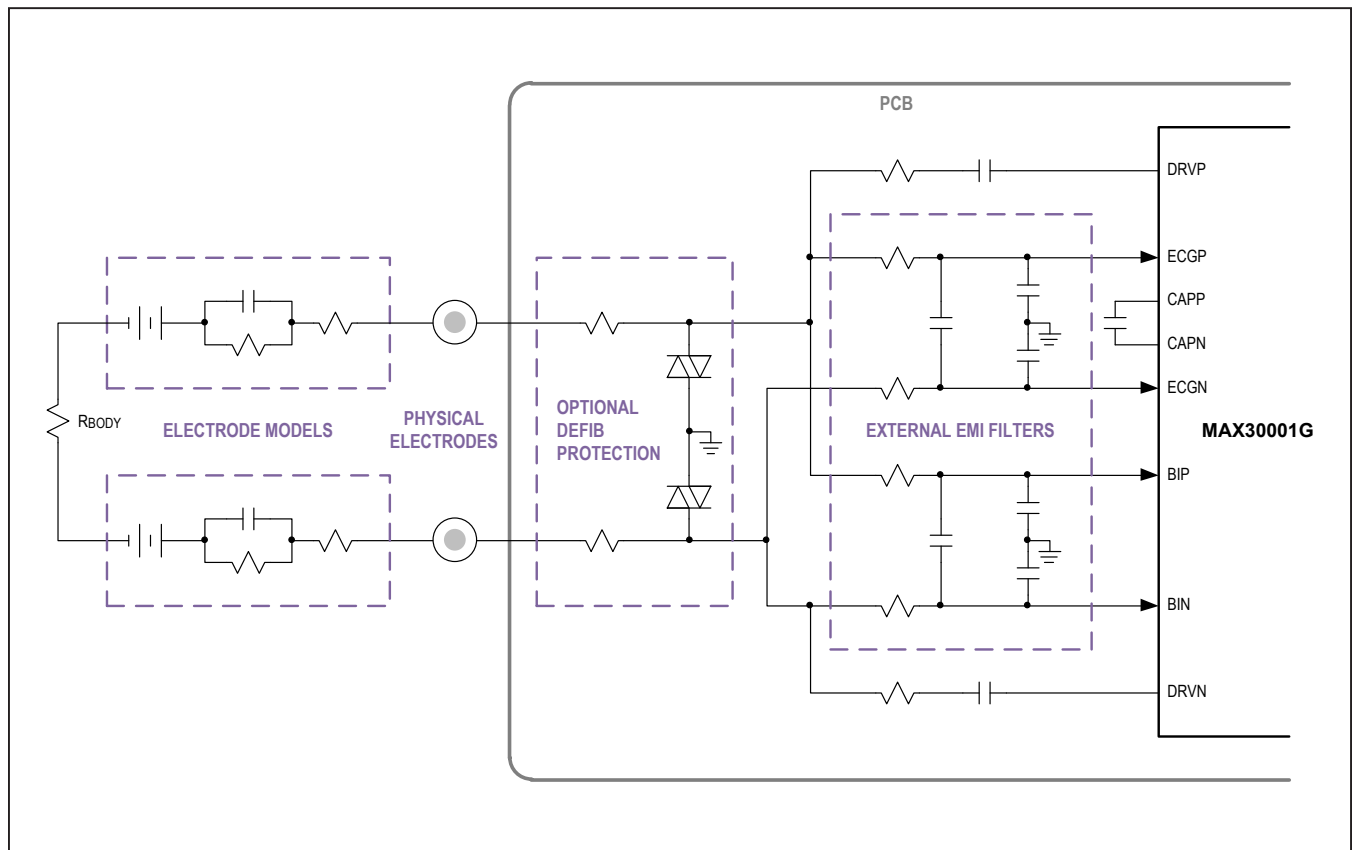

Figure 17. Two Electrode ECG and Respiration Monitoring with Optional Common Defibrillation Protection.

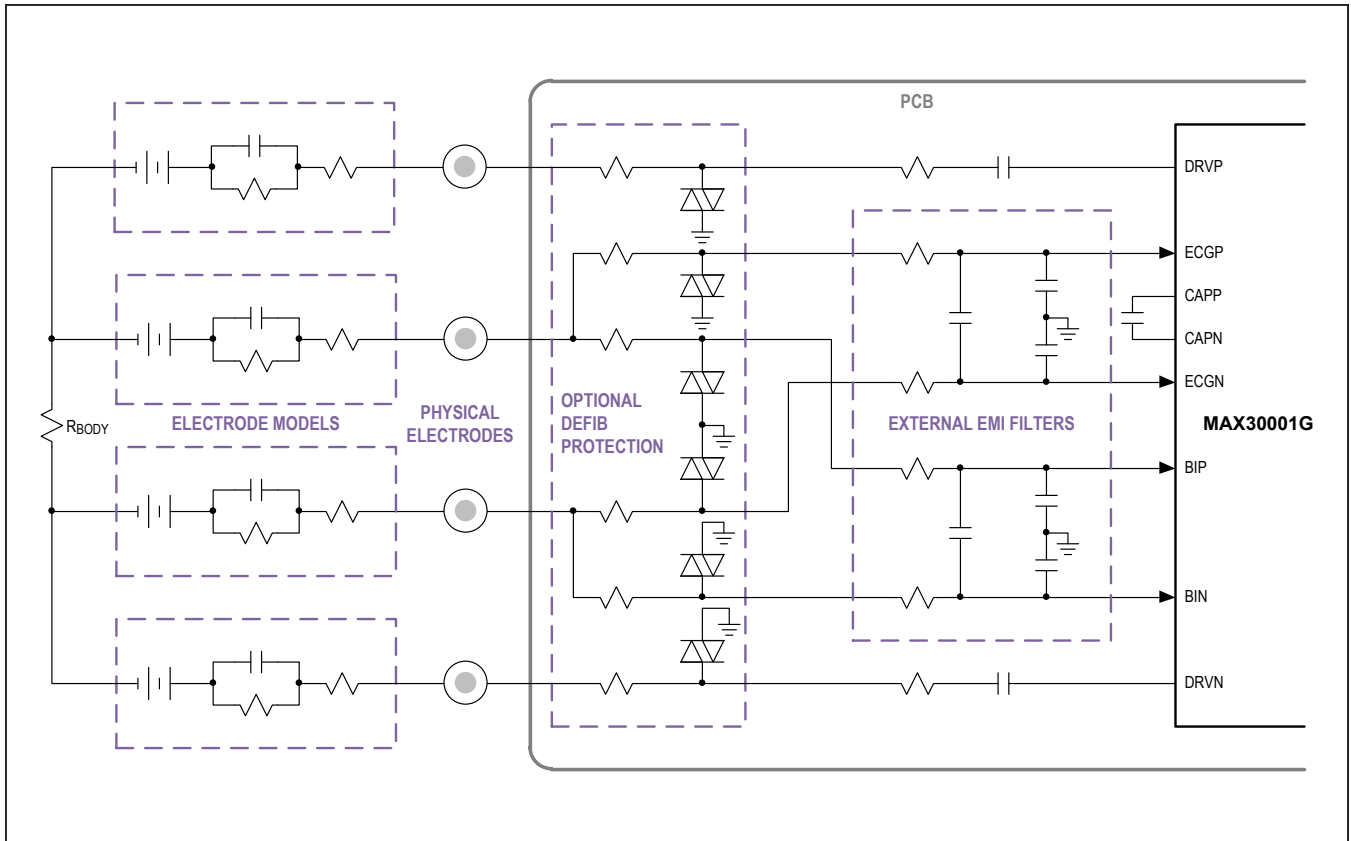

Figure 18. Four Electrode ECG and Respiration Monitoring with Optional Defibrillation Protection.



MAX30001G

Ultra-Low-Power, Single-Channel Integrated  
Biopotential (ECG and R-to-R)  
and Bioimpedance (BioZ) AFE

### Ordering Information

PART	TEMP RANGE	PIN-PACKAGE
MAX30001GCWV+	0°C TO +70°C	30 WLP
MAX30001GCWV+T	0°C TO +70°C	30 WLP

+Denotes lead(Pb)-free/RoHS-compliant package.  
T = Tape and reel.

### Chip Information

PROCESS: CMOS

MAX30001G

Ultra-Low-Power, Single-Channel Integrated  
Biopotential (ECG and R-to-R)  
and Bioimpedance (BioZ) AFE

## Revision History

REVISION NUMBER	REVISION DATE	DESCRIPTION	PAGES CHANGED
0	3/20	Initial release	—

For pricing, delivery, and ordering information, please visit Maxim Integrated's online storefront at <https://www.maximintegrated.com/en/storefront/storefront.html>.

*Maxim Integrated cannot assume responsibility for use of any circuitry other than circuitry entirely embodied in a Maxim Integrated product. No circuit patent licenses are implied. Maxim Integrated reserves the right to change the circuitry and specifications without notice at any time. The parametric values (min and max limits) shown in the Electrical Characteristics table are guaranteed. Other parametric values quoted in this data sheet are provided for guidance.*