

IWR-1

SINGLE CHANNEL WIRELESS RECEIVER



The IWR-1 is a single channel receiver designed to pair with any of the Sensata range of IWT wireless transmitters to form a cost-effective replacement of traditional wired transducers. This offers a low cost solution to inaccessible or expensive installation environment.

The receiver has a user selectable voltage or mA output corresponding to the calibrated range of the remote Wireless Transducer and 5A rated changeover contacts for alarm functionality.

User configuration is possible, however the single channel transmitter/receiver combination is designed to work 'out of the box' offering a simple plug and play solution to remote measurement applications. With the standard 0dBI antenna, a line-of-sight range of up to 500 m can be achieved and, using the optional 3dBI antenna, up to 750m (LOS) is achievable.

Features

- Pairs with the IWT range of wireless transmitters
- User-selectable 1-5V or 4-20 mA receiver output
- Clean contact output for process, low battery or loss of signal alarm function
- Simple DIL switch pairing with the IWT transmitters
- Up to 500 m range, line-of-sight
- 12 to 32 V dc powered
- End-to-end accuracy of $\pm 0.25\%$ FS BFSL
- LED indication of wireless link
- DIN rail or wall mounting kits available
- Five channel receiver available - see data sheet IWR-5

SPECIFICATIONS

Electrical Protection

Outputs*	User selectable 1-5V or 4-20 mA
Alarm Output	5 Amp rated changeover contacts
Receiver Update Rate**	10 seconds as standard
	Alternative user settable rates: - 1, 5, 10 and 30 seconds

*Factory preset is 4-20 mA output

**Consult relevant IWT Installation manual and data sheet for set-up of alternative transmission rates.

Enclosure Specifications

Dimensions	120 mm x 80 mm x 57 mm
Material*	Light grey ABS (RAL7035)
Protection Class	IP65
Weight	215g inc. 0dBI antenna (+12g with 3dBI)
Installation Position**	Any

*Other materials on request.

**Consult Installation Manual to ensure adequate signal path between transmitter and receiver.

Receiver Input

Receiver Frequency*	2.4GHz
System Channel	Standard setting, however user adjustable in multiple instrument systems
Antenna	Enclosure mounted 0dBi

*Compliant with EN 300 328, V1.8.1

System Performance (@ +20°C)

Accuracy	<±0.25% FS BFSL
Setting Errors (offsets)*	Zero and Full Scale <±0.5% FS

*End-to-end zero tare function available, see user manual.

Instrument Power Source

DC Power	12 to 32 V dc
-----------------	---------------

Temperature Ratings

Operating Temperature	-10°C to +50°C
Storage Temperature	-20°C to +80°C

DIMENSIONS

All dimensions are in millimeters.

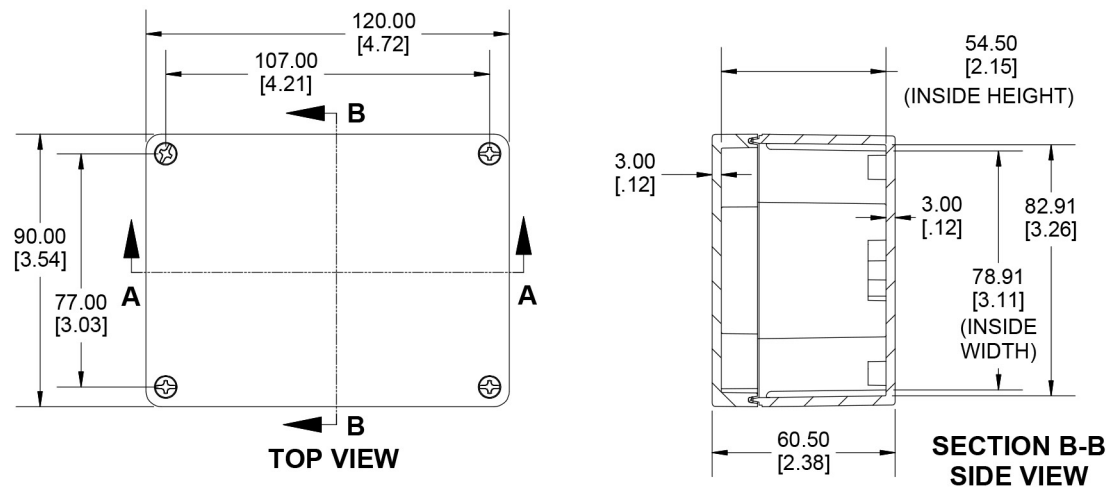



Transmitters	See IWT datasheets
Single Channel Receiver	IWR-1
Five Channel Receiver	IWR-5
Five Channel Configuration Software*	IWR-Set
3dBi Antenna (enclosure mount)	IANT-3

*Download free user configuration software here:
https://www.cynergy3.com/sites/default/files/IWR-Set_v2.4_installer.zip

Made in the UK

Sensata Technologies, Inc. ("Sensata") data sheets are solely intended to assist designers ("Buyers") who are developing systems that incorporate Sensata products (also referred to herein as "components"). Buyer understands and agrees that Buyer remains responsible for using its independent analysis, evaluation and judgment in designing Buyer's systems and products. Sensata data sheets have been created using standard laboratory conditions and engineering practices. Sensata has not conducted any testing other than that specifically described in the published documentation for a particular data sheet. Sensata may make corrections, enhancements, improvements and other changes to its data sheets or components without notice.

Buyers are authorized to use Sensata data sheets with the Sensata component(s) identified in each particular data sheet. HOWEVER, NO OTHER LICENSE, EXPRESS OR IMPLIED, BY ESTOPPEL OR OTHERWISE TO ANY OTHER SENSATA INTELLECTUAL PROPERTY RIGHT, AND NO LICENSE TO ANY THIRD PARTY TECHNOLOGY OR INTELLECTUAL PROPERTY RIGHT, IS GRANTED HEREIN. SENSATA DATA SHEETS ARE PROVIDED "AS IS". SENSATA MAKES NO WARRANTIES OR REPRESENTATIONS WITH REGARD TO THE DATA SHEETS OR USE OF THE DATA SHEETS, EXPRESS, IMPLIED OR STATUTORY, INCLUDING ACCURACY OR COMPLETENESS. SENSATA DISCLAIMS ANY WARRANTY OF TITLE AND ANY IMPLIED WARRANTIES OF MERCHANTABILITY, FITNESS FOR A PARTICULAR PURPOSE, QUIET ENJOYMENT, QUIET POSSESSION, AND NON-INFRINGEMENT OF ANY THIRD PARTY INTELLECTUAL PROPERTY RIGHTS WITH REGARD TO SENSATA DATA SHEETS OR USE THEREOF.

All products are sold subject to Sensata's terms and conditions of sale supplied at www.sensata.com SENSATA ASSUMES NO LIABILITY FOR APPLICATIONS ASSISTANCE OR THE DESIGN OF BUYERS' PRODUCTS. BUYER ACKNOWLEDGES AND AGREES THAT IT IS SOLELY RESPONSIBLE FOR COMPLIANCE WITH ALL LEGAL, REGULATORY AND SAFETY-RELATED REQUIREMENTS CONCERNING ITS PRODUCTS, AND ANY USE OF SENSATA COMPONENTS IN ITS APPLICATIONS, NOTWITHSTANDING ANY APPLICATIONS-RELATED INFORMATION OR SUPPORT THAT MAY BE PROVIDED BY SENSATA.

Mailing Address: Sensata Technologies, Inc., 529 Pleasant Street, Attleboro, MA 02703, USA.

CONTACT US

EUROPE
+44 (0)1202 897969
c3w_sales@sensata.com
Cynergy3 Components Ltd.
7 Cobham Road,
Ferndown Industrial Estate,
Wimborne, Dorset,
BH21 7PE, United Kingdom

USA
+1 310 561 8092 / +1 866 258 5057
c3w_sales@sensata.com