



User Guide

MP2723A Evaluation Kit (EVKT-MP2723A)

Table of Contents

Overview.....	3
Introduction	3
Kit Contents	3
Features and Benefits	4
Kit Specifications.....	5
Section 1. Hardware Specifications.....	6
1.1 Personal Computer Requirements	6
1.2 EV2723A-QC-00A Specifications	6
1.3 EVKT-USBI2C-02 Specifications.....	6
Section 2. Software Requirements.....	7
2.1 Software Installation Procedure.....	7
Section 3. Evaluation Kit Test Set-Up	8
3.1 Hardware Set-Up.....	8
3.2 Powering Up the EVB.....	8
3.3 Software Set-Up.....	9
3.4 Troubleshooting Tips.....	10
Section 4. Ordering Information	11

Overview

Introduction

The EVKT-MP2723A is an evaluation kit for the MP2723A when it is used as a standalone switching charger with integrated USB detection and USB On-The-Go (OTG) operation. The board's layout accommodates most commonly used capacitors. The default function of this board is preset for charger mode, and the charge-full voltage is preset to 4.2V for a single-cell Li-ion battery.

Kit Contents

EVKT-MP2723A kit contents (items below can be ordered separately, and the GUI installation file and supplemental documents can be downloaded from the MPS website):

#	Part Number	Item	Quantity
1	EV2723A-QC-00A	MP2723A evaluation board	1
2	EVKT-USBI2C-02 bag	Includes one USB to I ² C communication interface, one USB cable, and one ribbon cable	1

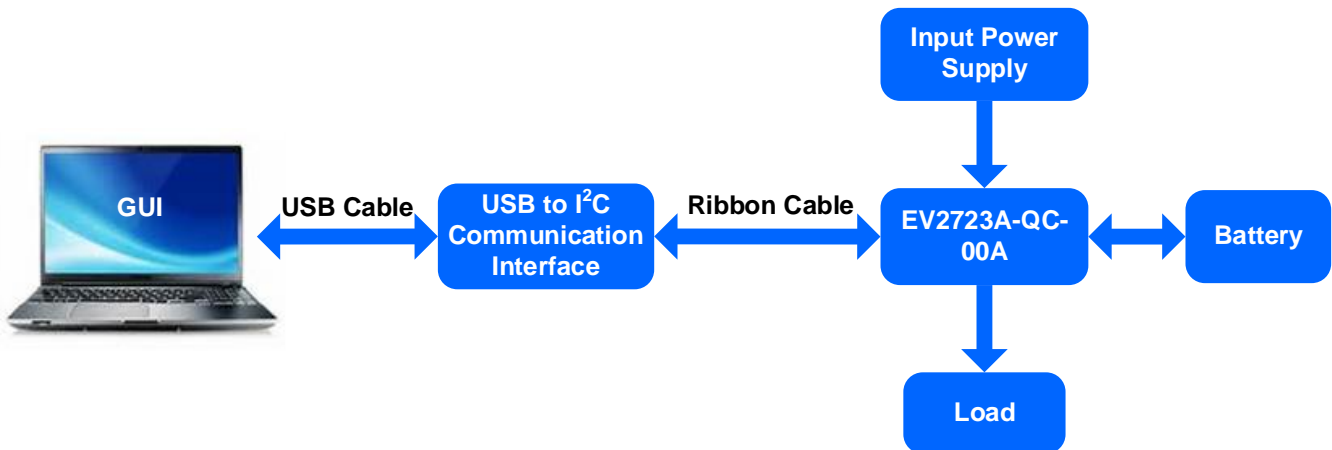

Figure 1: EVKT-MP2723A Evaluation Kit Set-Up

Features and Benefits

- 3.7V to 5.5V Operating Input Voltage (V_{IN}) Range
- Up to 22V Sustainable Voltage
- High-Efficiency, 3A, 1.35MHz Buck Charger
 - Up to 92% Charge Efficiency at 3A Charge Current
 - Auto-Detection for USB Standard Downstream Port (SDP), Charging Downstream Port (CDP), Dedicated Charging Port (DCP), and Non-Standard Adapters
- USB On-The-Go (OTG) with 4.8V to 5.5V Adjustable Output: Up to 1.5A Output and 93% Efficiency
- High Battery Discharge Efficiency with 14m Ω BATFET up to 8.5A
- Integrated Analog-to-Digital Converter (ADC) for Monitoring V_{IN} , Input Current, Battery Voltage, Charge Current, System Voltage, and Battery Temperature
- Narrow Voltage DC (NVDC) Power Path Management
 - Instant-On Works with No Battery or Deeply Discharged Battery
 - Ideal Diode Operation in Battery Supplemental Mode
- Constant-Off-Time Control to Reduce Charging Time under Lower V_{IN} Conditions
- I²C Port for Flexible System Parameter Setting and Status Reporting
- Full DISC Control to Support Shipping Mode and System Restart
- High Accuracy
 - $\pm 0.5\%$ Charge Voltage Regulation
 - $\pm 5\%$ Charge Current Regulation
 - $\pm 5\%$ Input Current Regulation
 - $\pm 2\%$ Output Regulation in Boost Mode
- High Integration
 - Fully Integrated Power Switches and No External Blocking Diode
 - Built-In Robust Charging Protection, including Battery Temperature Monitoring and Configurable Timer
 - Built-In Battery Disconnection Function
- Safety
 - Configurable JEITA for Battery Temperature Protection
 - Thermal Regulation and Thermal Shutdown
 - Watchdog Monitoring I²C Operation
 - Input/System Over-Voltage Protection (OVP)
 - MOSFET Over-Current Protection (OCP)
 - Supports Temperature Protection in Battery Side
- Charging Operation Indicator
- On-Chip Thermal Limiting Regulation

 *All changes made in I²C mode are not retained once the EVB shuts down.*

 *Information written in OTP mode cannot be changed.*

Adjustable Features

PC	OTP
<ul style="list-style-type: none"> • Charge-Full Voltage • Charge Current • V_{IN} Regulation • Input Current Limit • Pre-Charge Current • Charge Termination Current • V_{SYS_MIN} Regulation Current • Auto-Recharge Threshold • NTC Comparing Ratio • OTG Voltage Regulation • OTG Current Limit 	<ul style="list-style-type: none"> • I_{IN_LIM} Default Value • V_{IN_MIN} Default Value • I_{CC} Default Value • V_{BATT_REG} Default Value • CHG_TMR Default Value • IINLIM RESET_EN Default Status • VINMIN RESET_EN Default Status • ADDRESS Default Status • PFM_EN Default Status

Kit Specifications

Features	Specification
Board Supply	3.7V to 5.5V
Operating Input Voltage	3.7V to 5.5V
Operating Systems Supported	Windows XP, 7, or later
System Requirements	Minimum 22.2MB free
GUI Software	MP2723A V1.0

Section 2. Software Requirements

2.1 Software Installation Procedure

Programming occurs through the MPS I²C GUI. Follow the instructions below to install the software:

Note: This software can be downloaded from the MPS website.

1. Download and extract the zip package titled “MP2723A I2C Evaluation GUI”.
2. Double-click the “.exe” file to open the software (see Figure 4). If a protection window comes up, click “More info,” then click “Run anyway.”
3. Follow the prompts in the set-up guide.
4. Wait for the status screen to verify that installation is complete (see Figure 5).

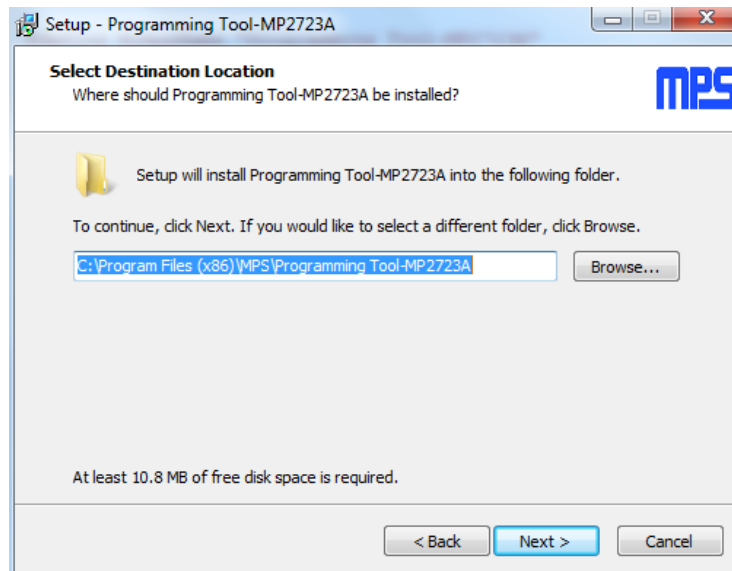

Figure 4: MPS I²C GUI Set-Up Guide

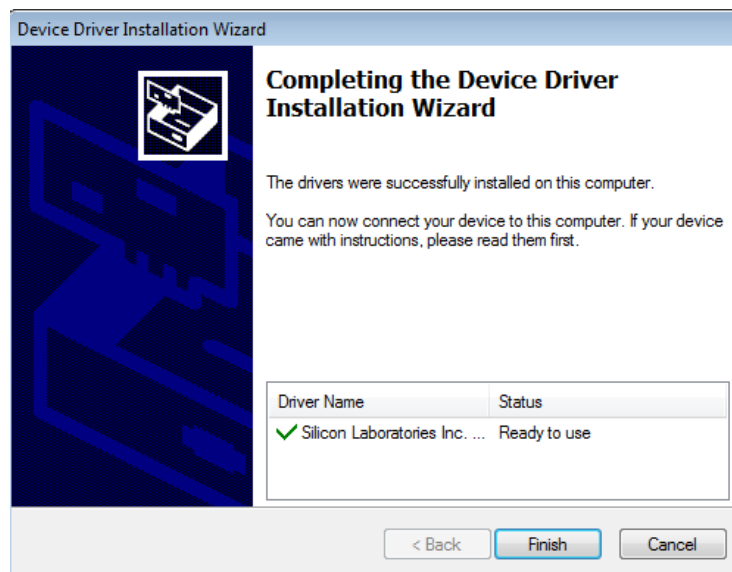

Figure 5: Driver Set-Up Success

Section 3. Evaluation Kit Test Set-Up

3.1 Hardware Set-Up

The hardware must be properly configured prior to use. Follow the instructions below to set up the EVB:

1. Locate the proper wires to connect the EVB to the EVKT-USBI2C-02 communication interface.
2. Connect SCL, SDA, and GND (see Figure 6). Refer to the MP2723A datasheet for further clarification.

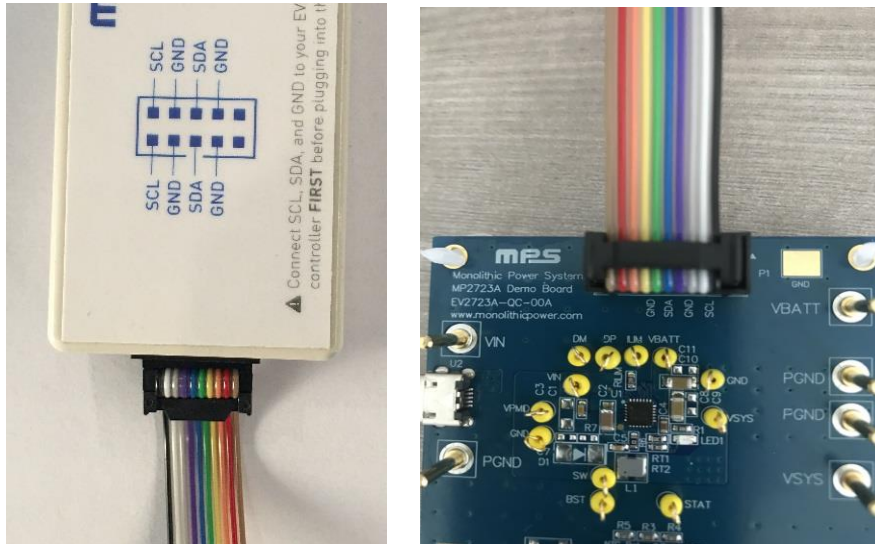

Figure 6: EVB to MPS I²C Communication Interface Wire Connection

3.2 Powering Up the EVB

1. Connect the load terminals to:
 - a. Positive (+): VSYS
 - b. Negative (-): PGND
2. Connect the battery terminals to:
 - a. Positive (+): VBATT
 - b. Negative (-): PGND
3. If using a battery simulator, preset the battery voltage between 0V and 4.2V, then turn it off.
4. Connect the battery simulator output to the BATT and PGND pins.
5. Preset the power supply output between 3.7V and 5.5V, then turn off the power supply.
6. Connect the power supply output terminals to:
 - a. Positive (+): VIN
 - b. Negative (-): PGND
7. Ensure the battery voltage is present, then turn on the power supply (if a battery simulator is used, turn on the battery simulator). The device should start up automatically.

3.3 Software Set-Up

After connecting the hardware according to the steps above, follow the steps below to use the GUI software:

1. Start the software. It should check the EVB connection automatically.
 - If the connection is successful, both the USB and evaluation board statuses should be listed as “Connected” in green (see Figure 7).

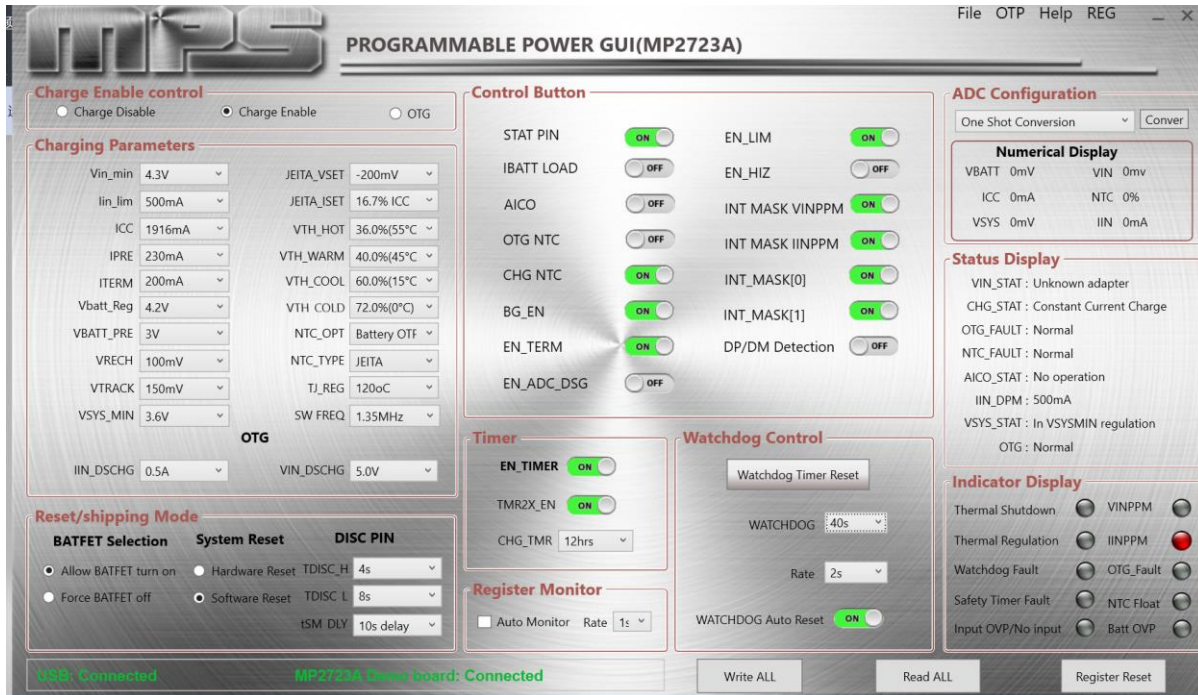

Figure 7: USB and MP2723A Demo Board Are Connected

- If the connection is unsuccessful, the statuses are listed as “Not Connected” in red. Check the connections between the EVB, communication interface, and PC. Re-plug the USB into the computer.
 - If the evaluation board is listed as “Not Connected,” this means that the evaluation board is not connected correctly.
 - If the USB is listed as “Not Connected,” this means that the USB I²C communication interface is not connected correctly.
2. Click the “Read All” button to read the I²C register values. The default values are displayed (see Figure 7).
 3. Find the item to be changed, then select the desired value from the drop-down menu.
 4. Click the “Write All” button to update values. The changed information should download to the IC.

⚠ All changes made via the I²C are restored to default values once the EVB shuts down.

3.4 Troubleshooting Tips

EVKT-USBI2C-02 Driver Installation Problem

If the USBI2C-02 driver is not properly installed, manual installation is required. Follow the steps below to manually install the EVKT-USBI2C-02 driver:

Note: Check the driver version. Find “USBXpress Device” in the Device Manager under USB controllers.

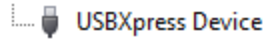

Right-click and view properties. Ensure the driver version matches the newest version. If the PC is running Windows 10, Windows 10 may automatically install the older USB driver, which is not compatible. The correct driver version should be newer than 4.0.0.0 (see Figure 8).

1. Install the correct USBXpress “.exe” file.

Choose either the 32-bit or 64-bit operating system.

32-bit: \EVKT-USBI2C-02 USB Driver\ USBXpressInstaller_x86.exe

64-bit: \EVKT-USBI2C-02 USB Driver\ USBXpressInstaller_x64.exe

2. Connect the EVKT-USBI2C-02 communication interface to the PC with the USB cable.

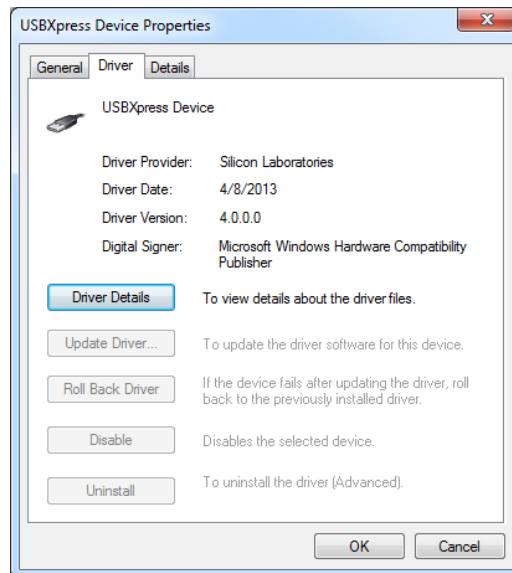

Figure 8: Correct Driver Version Should Be Newer than 4.0.0.0

No Supply

The IC’s input pin has an under-voltage lockout (UVLO) detection circuit. If the input voltage (V_{IN}) is below the UVLO rising threshold, the charging function is disabled.

No Charging Event

If the IC detects that V_{IN} is below the UVLO falling threshold (the device enters a no-supply state) or over-temperature protection (OTP) is triggered (the device enters a shutdown state), then the IC stops switching and charging is suspended.

Thermal Recovery

If the die temperature exceeds the thermal protection threshold, then the MP2723A enters a shutdown state. The IC starts up again once the die temperature decreases.

Section 4. Ordering Information

The components of the evaluation kit can be purchased separately, depending on user needs. The GUI installation file and supplemental documents can be downloaded from the MPS website.

Part Number	Description
EVKT-MP2723A	Complete evaluation kit
Contents of EVKT-MP2723A	
EV2723A-QC-00A	MP2723A evaluation board
EVKT-USBI2C-02 bag	Include one USB to I ² C USB communication interface, one USB cable, and one ribbon cable

Order directly from MonolithicPower.com or our distributors.

REVISION HISTORY

Revision #	Revision Date	Description	Pages Updated
1.0	11/02/2021	Initial Release	-

Notice: The information in this document is subject to change without notice. Please contact MPS for current specifications. Users should warrant and guarantee that third-party Intellectual Property rights are not infringed upon when integrating MPS products into any application. MPS will not assume any legal responsibility for any said applications.