

# ROTARY CODED SWITCHES

# S-1000A/2000A

## RoHS compliant

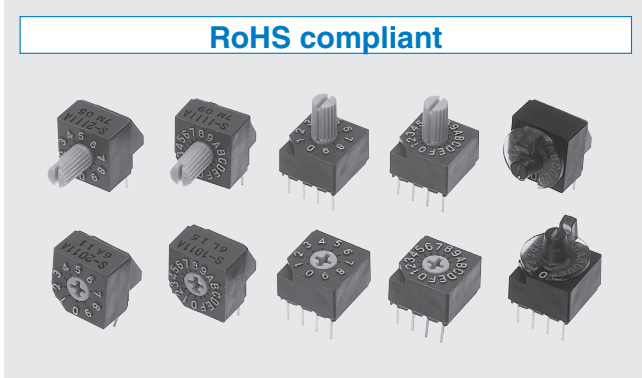

## FEATURES

- RoHS compliant
- Protection against dust and whole cleaning after soldering is possible
- Pin compatible with conventional DIP switches
- Translucent knob with flange type (S-1200A/2200A series)
  - Distinguished visibility with translucent flange
  - Settable with fingers or screwdriver

## INTERNAL STRUCTURE S-1000A / 2000A series

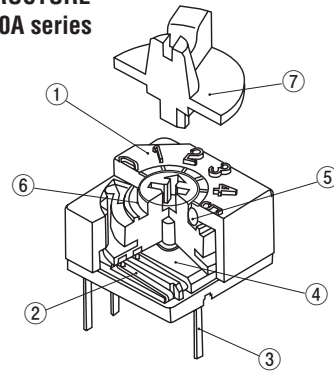

Part name	Material	Flammability
① Housing	PBT Polybutyleneterephthalate	UL94HB
② Contact	Copper alloy, Gold-plated	—
③ Terminal pin		
④ Base	PBT Polybutyleneterephthalate	UL94HB
⑤ "O" ring	Silicone rubber	
⑥ Insert rotor	Rotor : Polyoxymethylene Pattern : Copper alloy, Gold-plated	UL94V-2
⑦ Translucent knob with flange	PAR (Polyarylate) ※ S-12 □□ A/22 □□ Aのみ S-12 □□ A/22 □□ A only	

## PART NUMBER DESIGNATION

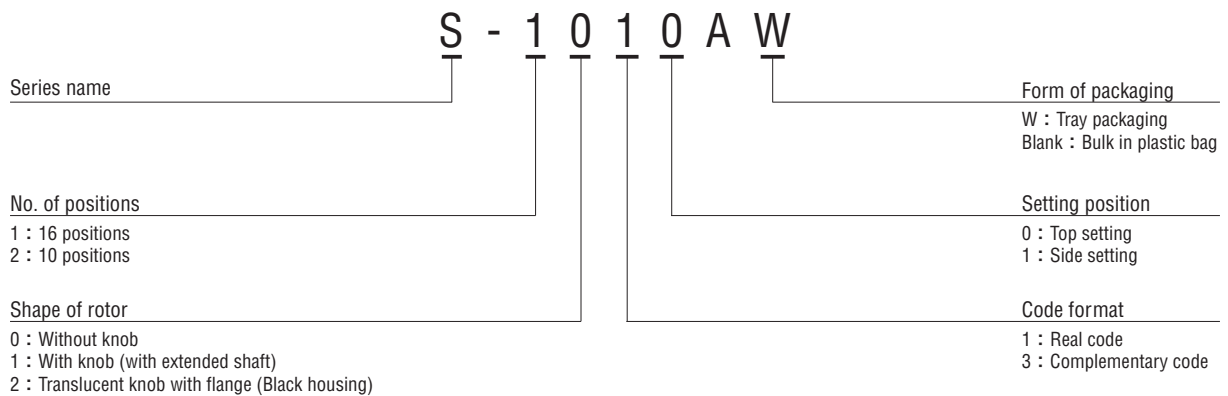

※ Please refer to the LIST OF PART NUMBERS when placing orders.





# S-1000A/2000A ROTARY CODED SWITCHES

## LIST OF PART NUMBERS

Shape	Form of packing	Binary coded decimal		Binary coded hexadecimal		Pieces in package	
		Real code	Complementary code	Real code	Complementary code		
Top setting	Without knob	Tray packaging	S-2010AW	S-2030AW	S-1010AW	S-1030AW	50 pcs./tray
		Plastic bag	S-2010A	S-2030A	S-1010A	S-1030A	25 pcs./pack
	With knob	Tray packaging	S-2110AW	S-2130AW	S-1110AW	S-1130AW	50 pcs./tray
		Plastic bag	S-2110A	S-2130A	S-1110A	S-1130A	25 pcs./pack
	Translucent knob with flange	Tray packaging	S-2210AW	S-2230AW	S-1210AW	S-1230AW	50 pcs./tray
		Plastic bag	S-2210A	S-2230A	S-1210A	S-1230A	25 pcs./pack
Side setting	Without knob	Tray packaging	S-2011AW	S-2031AW	S-1011AW	S-1031AW	50 pcs./tray
		Plastic bag	S-2011A	S-2031A	S-1011A	S-1031A	25 pcs./pack
	With knob	Tray packaging	S-2111AW	S-2131AW	S-1111AW	S-1131AW	50 pcs./tray
		Plastic bag	S-2111A	S-2131A	S-1111A	S-1131A	25 pcs./pack
	Translucent knob with flange	Tray packaging	S-2211AW	S-2231AW	S-1211AW	S-1231AW	50 pcs./tray
		Plastic bag	S-2211A	S-2231A	S-1211A	S-1231A	25 pcs./pack

※ Verify the above part numbers when placing orders.  
Tray version can be supplied only in tray units.

## TERMINAL CONNECTION / P.C.B. THROUGH HOLE DIMENSIONS (Unit: mm)

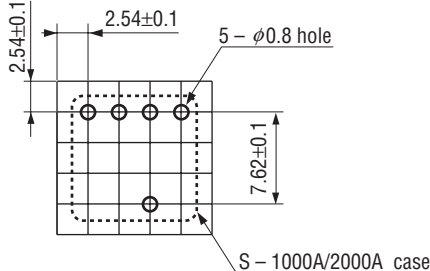
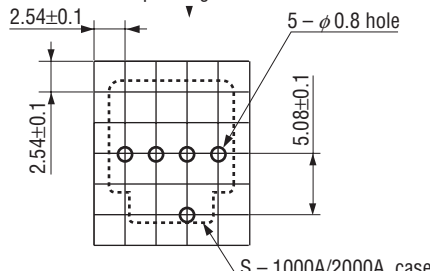
	Top setting	Side setting
Terminal pin layout (Bottom view)	<p>Real code</p>  <p>Complementary code</p> 	<p>Operating face of real code</p>  <p>Operating face of complementary code</p> 
P.C.B. dimensions (Bottom view)		

## CODE FORMAT

No. of positions		S-1000A series (16 positions)																
		S-2000A series (10 positions)										A	B	C	D	E	F	
Position		0	1	2	3	4	5	6	7	8	9	A	B	C	D	E	F	
Code	Real code	8								●	●	●	●	●	●	●	●	
		4					●	●	●	●			●	●	●	●	●	
		2			●	●			●	●			●	●			●	●
	Complementary code	8	●	●	●	●	●	●	●	●								
		4	●	●	●	●					●	●	●	●				
		2	●	●			●	●			●	●			●	●		
		●	●			●	●			●	●	●	●		●			

● ... Contact closed

# S-1000A/2000A

## ROTARY CODED SWITCHES

### STANDARD SPECIFICATIONS

Circuit type	BCD (Real code, complementary code) BCH (Real code, complementary code)
Operating temperature range	- 40 ~ 85 °C
Storage temperature range	
Sealing	Washable by "O" ring ※ Please refer to page 150,151
Net weight	Approx. 0.87 g (S-1010A, S-1030A, S-2010A, S-2030A) Approx. 1.13 g (S-1011A, S-1031A, S-2011A, S-2031A) Approx. 0.97 g (S-1110A, S-1130A, S-2110A, S-2130A) Approx. 1.23 g (S-1111A, S-1131A, S-2111A, S-2131A) Approx. 1.02 g (S-1210A, S-1230A, S-2210A, S-2230A) Approx. 1.28 g (S-1211A, S-1231A, S-2211A, S-2231A)

### MECHANICAL CHARACTERISTICS

No. of positions	16 (S-1000A), 10 (S-2000A)
Adjustment torque	13 mN·m {133 gf·cm} minimum
Stepping angle	22.5° (S-1000A), 36° (S-2000A)
Terminal strength	15 N {1.53 kgf} minimum
Solderability	245 ± 3 °C, 2 ~ 3 s
Soldering heat	Flow : 260 ± 3 °C as the temperature in a pot of molten solder, immersion from head of terminal to backside of board, 5 ~ 6 s, two times maximum
	Manual soldering : 380 ± 10 °C, 3 ~ 4 s

{ } : Reference only

### ELECTRICAL CHARACTERISTICS

Contact rating Non-switching Switching Minimum	DC50 V 100 mA DC5 V 100 mA DC20 mV 1 μ A
Contact resistance	100 m Ω maximum
Insulation resistance	1000 M Ω (DC100 V) minimum
Dielectric strength	AC300 V, 60 s

### ENVIRONMENTAL CHARACTERISTICS

Vibration	Amplitude 1.5 mm or Acceleration 98 m/s <sup>2</sup> , 10-500-10 Hz, 3 directions for 2 h each
Shock	490 m/s <sup>2</sup> , 11 ms 6 directions for 3 times each
Load life	10000 steps DC5 V, 100 mA
Humidity (Steady state)	Resistance load DC50V 100mA 60 °C, Relative humidity 90 ~ 95 %, 1000 h
High temperature exposure	85 °C, 1000 h
Low temperature exposure	- 40 °C, 96 h
Thermal shock	- 40 (0.5 h) ~ 85 °C ( 0.5 h ), 5 cycles

# S-1000A/2000A

## ROTARY CODED SWITCHES

### OUTLINE DIMENSIONS

Unless otherwise specified, tolerance:  $\pm 0.3$  (Unit: mm)

(S-1000A series)

- S-1010A
  - S-1030A
- Top setting

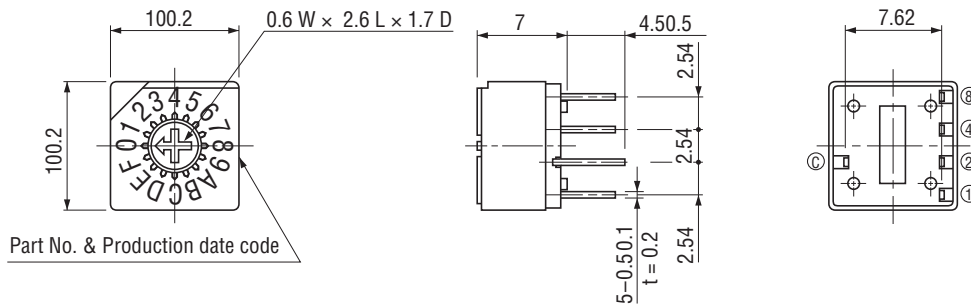

- S-1011A
  - S-1031A
- Side setting

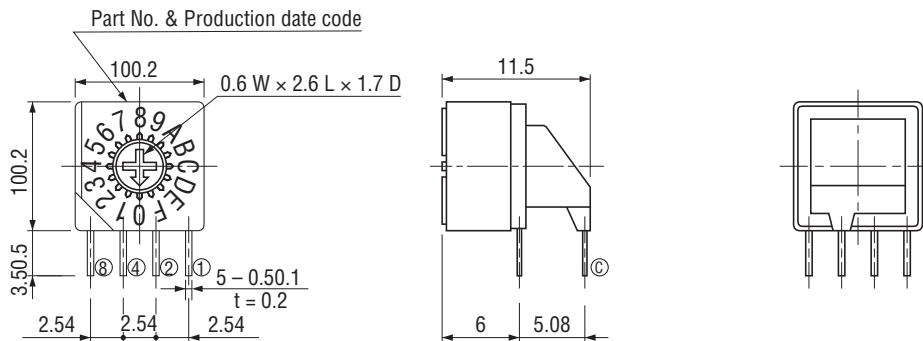

- S-1110A
  - S-1130A
- Top setting

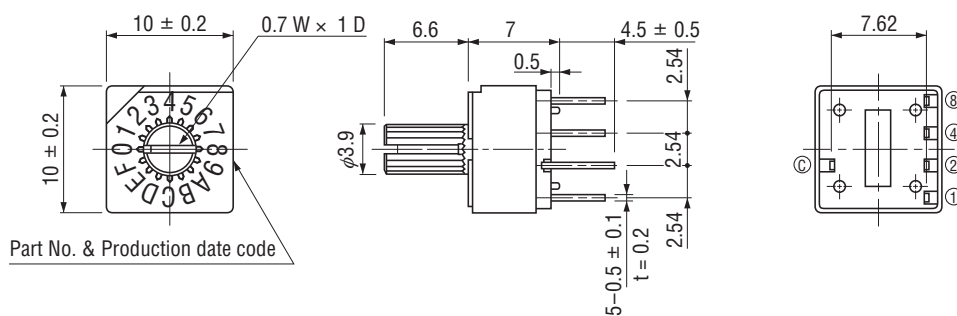

- S-1111A
  - S-1131A
- Side setting

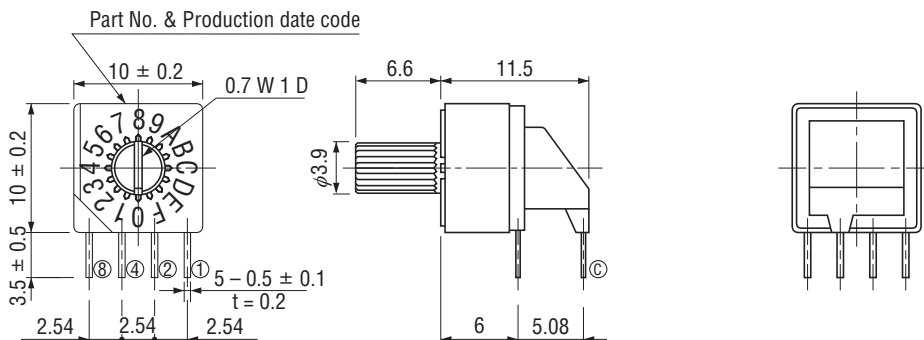

# S-1000A/2000A

## ROTARY CODED SWITCHES

### OUTLINE DIMENSIONS

Unless otherwise specified, tolerance:  $\pm 0.3$  (Unit: mm)

(S-2000A series)

- S-2010A
  - S-2030A
- Top setting

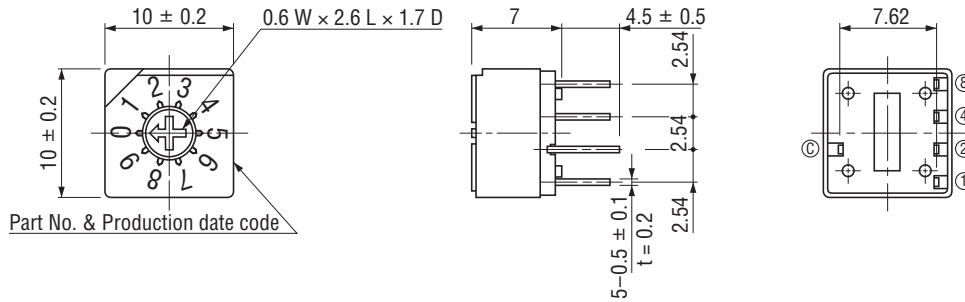

- S-2011A
  - S-2031A
- Side setting

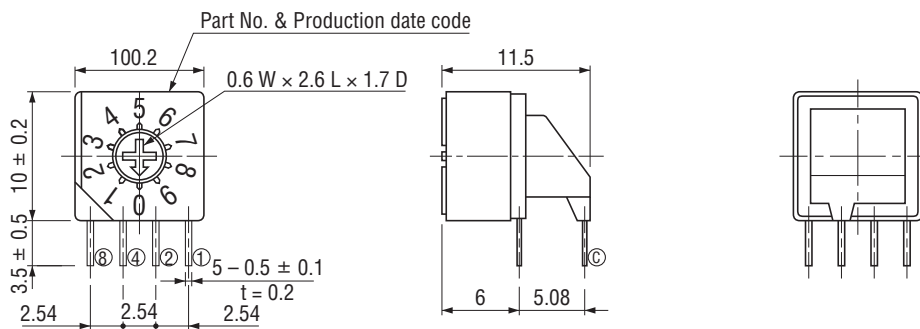

- S-2110A
  - S-2130A
- Top setting

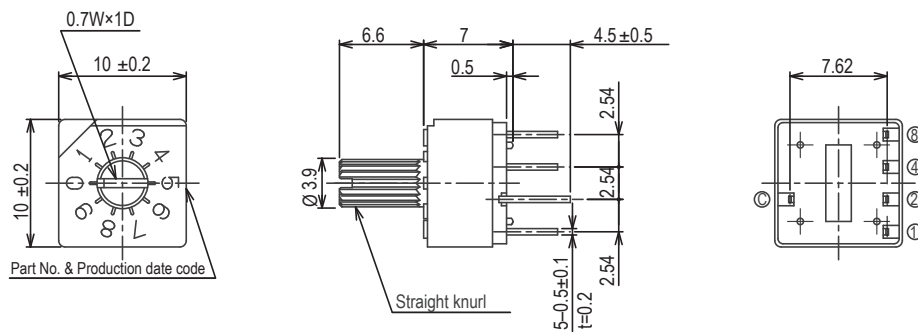

- S-2111A
  - S-2131A
- Side setting

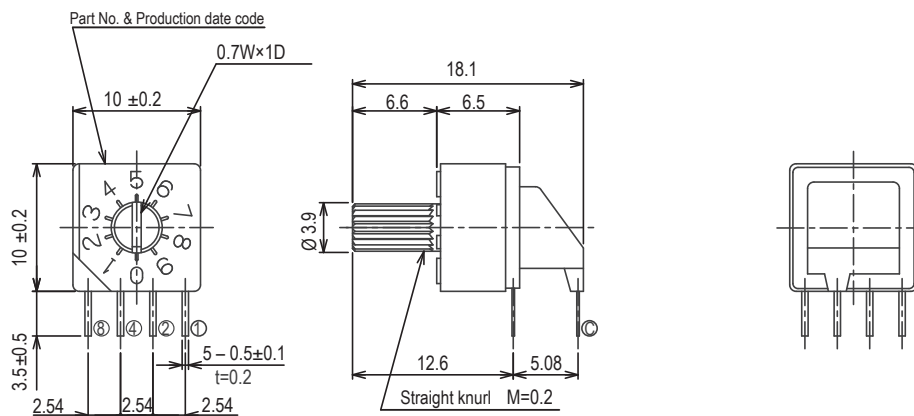

# S-1000A/2000A

## ROTARY CODED SWITCHES

### OUTLINE DIMENSIONS

Unless otherwise specified, tolerance:  $\pm 0.3$  (Unit: mm)

(S-1200A/2200A series)

- S-1210A
  - S-1230A
- Top setting

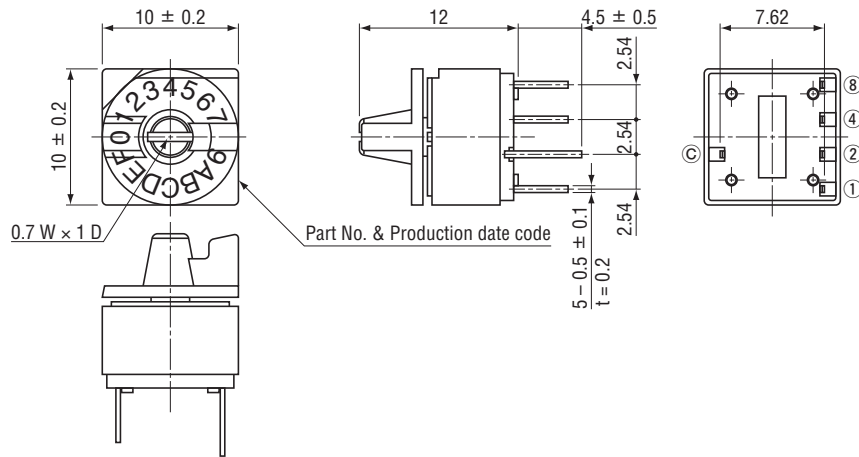

- S-1211A
  - S-1231A
- Side setting

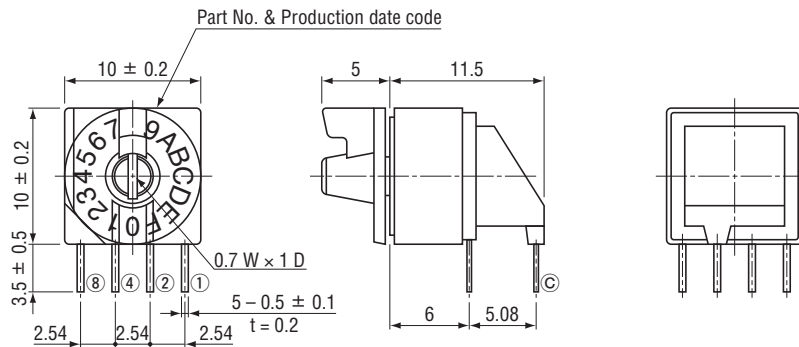

- S-2210A
  - S-2230A
- Top setting

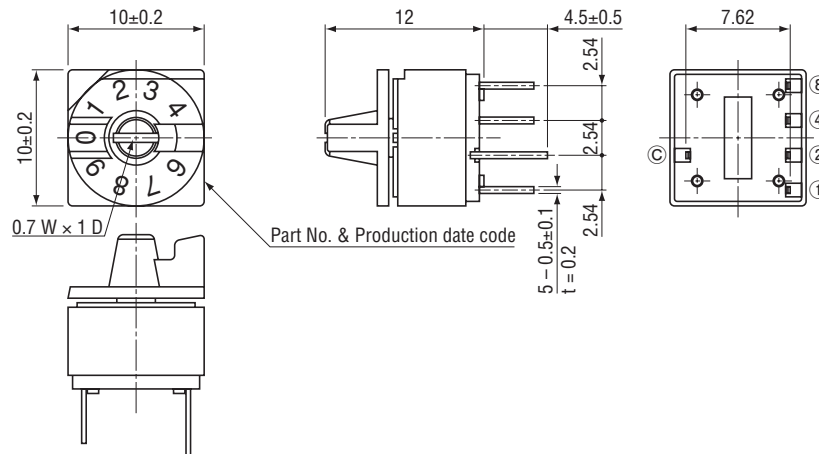

- S-2211A
  - S-2231A
- Side setting

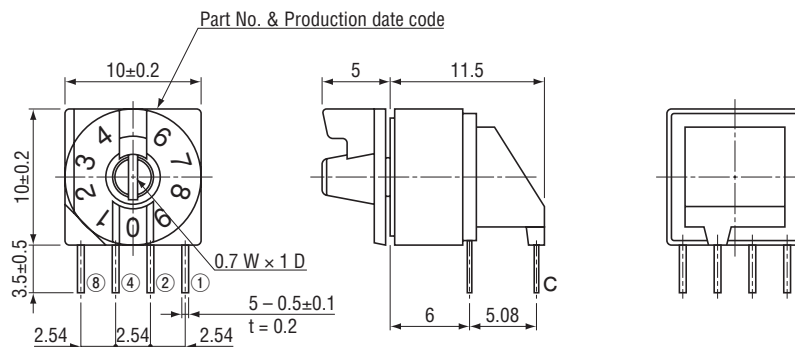

# S-1000A/2000A

## ROTARY CODED SWITCHES

### ■ Snap-in terminal pin with translucent knob with flange (Made to order basis)

#### ● S-1200AK and S-2200AK

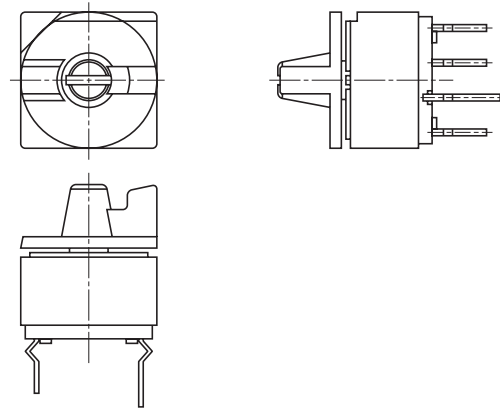
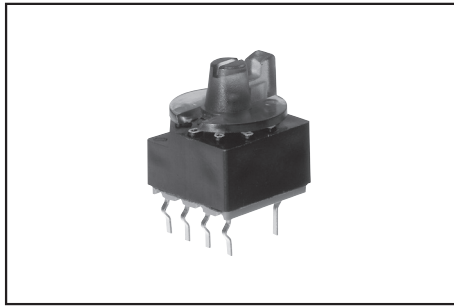

### ■ PACKAGING SPECIFICATIONS

#### <Tray packaging specifications>

- Tray version is packaged in 50 pcs. per tray. Orders will be accepted for units of 50 pcs., i. e., 50, 100, 150 pcs. etc.
- Tray version is boxed with 10 trays.

#### <Bulk pack specifications>

- The smallest unit of bulk pack in a plastic bag is 10 pcs. per pack. Orders will be accepted for unit of minimum 10 pcs., i.e., 10, 20, 30 pcs. , etc.
- Boxing of bulk in a plastic bag is performed with 25 pcs. (standard 50 pcs.) per box.

### ■ SWITCHES WITH KNOB AS EXTENDED SHAFT

(Unit: mm)

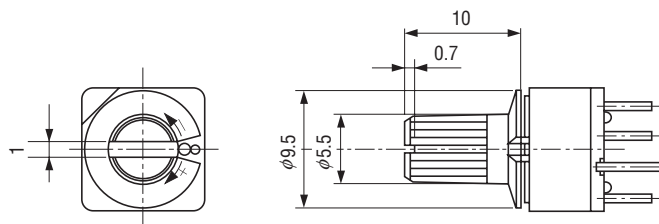

The large knob is common to S-1000A, S-2000A, SA-5000 and SS-10 series.

※ Knob can't be detached due to being fixed. Simple knob can't be sold.