



MICROCHIP

**LAN9360 Evaluation Board
V2.3.0**

(EVB-LAN9360)

User's Guide

Note the following details of the code protection feature on Microchip devices:

- Microchip products meet the specifications contained in their particular Microchip Data Sheet.
- Microchip believes that its family of products is secure when used in the intended manner and under normal conditions.
- There are dishonest and possibly illegal methods being used in attempts to breach the code protection features of the Microchip devices. We believe that these methods require using the Microchip products in a manner outside the operating specifications contained in Microchip's Data Sheets. Attempts to breach these code protection features, most likely, cannot be accomplished without violating Microchip's intellectual property rights.
- Microchip is willing to work with any customer who is concerned about the integrity of its code.
- Neither Microchip nor any other semiconductor manufacturer can guarantee the security of its code. Code protection does not mean that we are guaranteeing the product is "unbreakable". Code protection is constantly evolving. We at Microchip are committed to continuously improving the code protection features of our products. Attempts to break Microchip's code protection feature may be a violation of the Digital Millennium Copyright Act. If such acts allow unauthorized access to your software or other copyrighted work, you may have a right to sue for relief under that Act.

Information contained in this publication is provided for the sole purpose of designing with and using Microchip products. Information regarding device applications and the like is provided only for your convenience and may be superseded by updates. It is your responsibility to ensure that your application meets with your specifications.

THIS INFORMATION IS PROVIDED BY MICROCHIP "AS IS". MICROCHIP MAKES NO REPRESENTATIONS OR WARRANTIES OF ANY KIND WHETHER EXPRESS OR IMPLIED, WRITTEN OR ORAL, STATUTORY OR OTHERWISE, RELATED TO THE INFORMATION INCLUDING BUT NOT LIMITED TO ANY IMPLIED WARRANTIES OF NON-INFRINGEMENT, MERCHANTABILITY, AND FITNESS FOR A PARTICULAR PURPOSE OR WARRANTIES RELATED TO ITS CONDITION, QUALITY, OR PERFORMANCE.

IN NO EVENT WILL MICROCHIP BE LIABLE FOR ANY INDIRECT, SPECIAL, PUNITIVE, INCIDENTAL OR CONSEQUENTIAL LOSS, DAMAGE, COST OR EXPENSE OF ANY KIND WHATSOEVER RELATED TO THE INFORMATION OR ITS USE, HOWEVER CAUSED, EVEN IF MICROCHIP HAS BEEN ADVISED OF THE POSSIBILITY OR THE DAMAGES ARE FORESEEABLE. TO THE FULLEST EXTENT ALLOWED BY LAW, MICROCHIP'S TOTAL LIABILITY ON ALL CLAIMS IN ANY WAY RELATED TO THE INFORMATION OR ITS USE WILL NOT EXCEED THE AMOUNT OF FEES, IF ANY, THAT YOU HAVE PAID DIRECTLY TO MICROCHIP FOR THE INFORMATION. Use of Microchip devices in life support and/or safety applications is entirely at the buyer's risk, and the buyer agrees to defend, indemnify and hold harmless Microchip from any and all damages, claims, suits, or expenses resulting from such use. No licenses are conveyed, implicitly or otherwise, under any Microchip intellectual property rights unless otherwise stated.

For information regarding Microchip's Quality Management Systems, please visit www.microchip.com/quality.

Trademarks

The Microchip name and logo, the Microchip logo, Adaptec, AnyRate, AVR, AVR logo, AVR Freaks, BesTime, BitCloud, chipKIT, chipKIT logo, CryptoMemory, CryptoRF, dsPIC, FlashFlex, flexPWR, HELDO, IGLOO, JukeBlox, KeeLoq, Klear, LANCheck, LinkMD, maXStylus, maXTouch, MediaLB, megaAVR, Microsemi, Microsemi logo, MOST, MOST logo, MPLAB, OptoLyzer, PackeTime, PIC, picoPower, PICSTART, PIC32 logo, PolarFire, Prochip Designer, QTouch, SAM-BA, SenGenuity, SpyNIC, SST, SST Logo, SuperFlash, Symmetricom, SyncServer, Tachyon, TempTrackr, TimeSource, tinyAVR, UNI/O, Vectron, and XMEGA are registered trademarks of Microchip Technology Incorporated in the U.S.A. and other countries.

APT, ClockWorks, The Embedded Control Solutions Company, EtherSynch, FlashTec, Hyper Speed Control, HyperLight Load, IntelliMOS, Libero, motorBench, mTouch, Powermite 3, Precision Edge, ProASIC, ProASIC Plus, ProASIC Plus logo, Quiet-Wire, SmartFusion, SyncWorld, Temux, TimeCesium, TimeHub, TimePictra, TimeProvider, Vite, WinPath, and ZL are registered trademarks of Microchip Technology Incorporated in the U.S.A.

Adjacent Key Suppression, AKS, Analog-for-the-Digital Age, Any Capacitor, AnyIn, AnyOut, BlueSky, BodyCom, CodeGuard, CryptoAuthentication, CryptoAutomotive, CryptoCompanion, CryptoController, dsPICDEM, dsPICDEM.net, Dynamic Average Matching, DAM, ECAN, EtherGREEN, In-Circuit Serial Programming, ICSP, INICnet, Inter-Chip Connectivity, JitterBlocker, KlearNet, KlearNet logo, memBrain, Mindi, MiWi, MPASM, MPF, MPLAB Certified logo, MPLIB, MPLINK, MultiTRAK, NetDetach, Omniscient Code Generation, PICDEM, PICDEM.net, PICKit, PICTail, PowerSmart, PureSilicon, QMatrix, REAL ICE, Ripple Blocker, SAM-ICE, Serial Quad I/O, SMART-I.S., SQI, SuperSwitcher, SuperSwitcher II, Total Endurance, TSHARC, USBCheck, VariSense, ViewSpan, WiperLock, Wireless DNA, and ZENA are trademarks of Microchip Technology Incorporated in the U.S.A. and other countries.

SQTP is a service mark of Microchip Technology Incorporated in the U.S.A.

The Adaptec logo, Frequency on Demand, Silicon Storage Technology, and Symmcom are registered trademarks of Microchip Technology Inc. in other countries.

GestIC is a registered trademark of Microchip Technology Germany II GmbH & Co. KG, a subsidiary of Microchip Technology Inc., in other countries.

All other trademarks mentioned herein are property of their respective companies.

© 2021, Microchip Technology Incorporated, All Rights Reserved.

ISBN: 978-1-5224-8102-7

Table of Contents

Preface	5
Introduction.....	5
Intended Use	5
Document Layout	6
Term Definitions	6
Recommended Reading.....	6
Customer Support	7
Document Revision History	7
Chapter 1. Introduction	9
1.1 Product Features	10
1.2 Functional Description	10
Chapter 2. PHY Daughter Board	11
Chapter 3. Board Details	
3.1 Electrical Characteristics	13
3.2 Connectors	13
3.2.1 CN1 and CN2 – Audio Sockets	13
3.2.2 J1 – USB Connector	13
3.2.3 J2-J5 – LAN PHY Daughter Board Connector	14
3.2.4 J26 – I2C/SPI Connector	14
3.2.5 J28 – Audio Interface A Connector	15
3.2.6 J29 – Audio Interface B Connector	16
3.2.7 J30 – I2C/SPI Port Header	17
3.3 Jumpers	18
3.3.1 J10 – Power Management Option	18
3.3.2 J11 – Reserved	18
3.3.3 J12 – SCL Connector	18
3.3.4 J13 – SDA Connector	18
3.3.5 J14 – Select SPI	19
3.3.6 J15 – Connect AVB Endpoint PLLIN/RK	19
3.3.7 J16 – Connect AVB Endpoint SRA Audio Interface A	19
3.3.8 J17 – Connect Microphone Clock to the AVB Endpoint	19
3.3.9 J18 – Connect Audio Codec Clock to the AVB Endpoint	19
3.3.10 J19 – Connect Audio Codec DAC to the AVB Endpoint	20
3.3.11 J20 – Connect Audio Codec LRCLK to the AVB Endpoint	20
3.3.12 J21 – Connect AVB Endpoint RF with AVB Endpoint EVIN	20
3.3.13 J22 – Erase Flash Memory of AVB Endpoint	20
3.3.14 J23 – Enable External Power for Analog Microphone	20

3.4 Buttons	21
3.5 LEDs	21
Chapter 4. Configuration Options	
4.1 Listener and/or Talker with On-Board Codec	24
4.2 Listener and/or Talker with External Codec/DSP	25
4.3 Talker with On-Board MEMS Mic (PDM) and Listener with On-Board Codec	26
4.4 Talker with On-Board MEMS Mic (PDM) and Listener with External Sink ...	27
4.5 Talker with External PCM Source and Listener with On-Board Codec	28
4.6 1PPS Method for Clock Accuracy Measurement	29
Chapter 5. Assembly Plan and Mechanical Dimensions	
5.1 Top View and Mechanical Dimensions	31
5.2 Bottom View and Mechanical Dimensions	32
List of Figures	35
List of Tables	37
Worldwide Sales and Service	38

Preface

NOTICE TO CUSTOMERS

All documentation becomes dated, and this manual is no exception. Microchip tools and documentation are constantly evolving to meet customer needs, so some actual dialogs and/or tool descriptions may differ from those in this document. Please refer to our web site (www.microchip.com) to obtain the latest documentation available.

Documents are identified with a “DS” number. This number is located on the bottom of each page, in front of the page number. The numbering convention for the DS number is “DSXXXXA”, where “XXXX” is the document number and “A” is the revision level of the document.

INTRODUCTION

This chapter contains general information that will be useful to know before using the EVB-LAN9360. Topics discussed in this chapter include:

- [Intended Use](#)
- [Document Layout](#)
- [Term Definitions](#)
- [Recommended Reading](#)
- [Customer Support](#)
- [Document Revision History](#)

INTENDED USE

This Microchip product is intended to be used for developing or testing AVB Audio End-point cases of application by persons with experience in developing multimedia devices.

Note: The operation of this Microchip product is only admitted with original Microchip devices.
Do not interfere with the product's original state. Otherwise user safety, faultless operation and electromagnetic compatibility are not ensured.
To avoid electric shocks and short circuits use this device only in an appropriate environment.
This open device may exceed the limits of electromagnetic interference.
Electromagnetic compatibility can be only achieved if the equipment is built into an appropriate housing.

EVB-LAN9360

DOCUMENT LAYOUT

This user's guide describes how to use the EVB-LAN9360. The document is organized as follows:

- [Chapter 1, Introduction](#) – This chapter introduces the EVB-LAN9360, lists the board features and shows the functional block diagram.
- [Chapter 2, PHY Daughter Board](#) – This chapter gives an overview of LAN PHY daughter boards.
- [Chapter 3, Board Details](#) – This chapter lists the electrical characteristics of the board. Furthermore, it describes the board components including connectors, jumpers, LEDs and buttons.
- [Chapter 4, Configuration Options](#) – This chapter lists some configuration options applicable with the board.
- [Chapter 5, Assembly Plan and Mechanical Dimensions](#) – This chapter shows the top- and bottom view of the board and the mechanical dimensions.
- [Appendix A](#) – This chapter shows a block diagram of the board including the jumpers that are required for board configuration.
- [List of Figures](#)
- [List of Tables](#)

TERM DEFINITIONS

This user's guide uses the following term definitions:

Term	Description
AVB	Audio Video Bridging
AVTP	Audio Video Transport Protocol
gPTP	Generalized Precision Time Protocol
LED	Light Emitting Diode
MEMS	Micro-Electro-Mechanical Systems
NC	Not Connected
PDM	Pulse-Density Modulation
PPS	Pulse per second
RTP	Real Time Protocol
USB	Universal Serial Bus

RECOMMENDED READING

This user's guide describes how to use the EVB-LAN9360. Other useful documents¹ are listed below.

[1] LAN8770 Data Sheet, Microchip

[2] LAN9360 Data Sheet, Microchip

1. To access these documents, it is required to submit a technical support case. Go to <http://www.microchip.com/support>. This directs you to the Microchip Technical Support Portal. If you are not acquainted with submitting a technical support case, read the article "How to submit a technical support case?".

CUSTOMER SUPPORT

Users of Microchip products can receive assistance through several channels:

- Distributor or Representative
- Local Sales Office
- Field Application Engineer (FAE)
- Technical Support

Customers should contact their distributor, representative or field application engineer (FAE) for support. Local sales offices are also available to help customers. A listing of sales offices and locations is included in the back of this document.

Technical support is available through the web site at:

<http://www.microchip.com/support>.

DOCUMENT REVISION HISTORY

Revision A (May 2021)

- Initial release of this document.

EVB-LAN9360

NOTES:

Chapter 1. Introduction

The EVB-LAN9360 is used to simulate an AVB Ethernet Endpoint that can be operated either as a Listener or a Talker. For that, the board provides a variety of functionalities that allow to prototype different types of Ethernet devices, such as a:

- remote amplifier,
- remote microphone or
- remote microphone array.

An image of the board (with an exchangeable LAN PHY daughter board) is shown in [Figure 1-1](#).

FIGURE 1-1: EVB-LAN9360

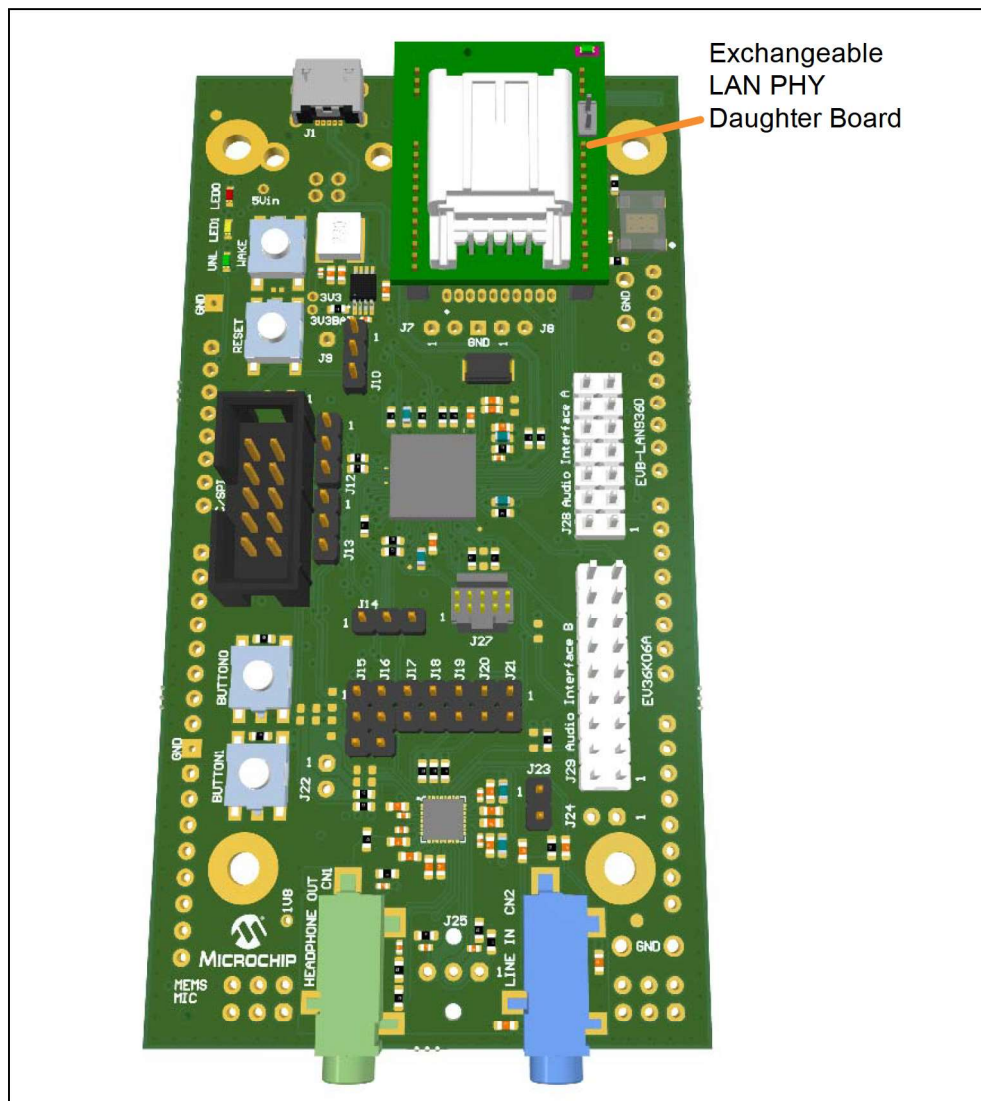

EVB-LAN9360

1.1 PRODUCT FEATURES

- Supports the following standards (and protocols):
 - IEEE Std 802.1AS™-2011 generalized Precision Time Protocol (gPTP) slave: time synchronization over the network
 - IEEE Std 1722™-2016 (AVTP), Talker and Listener
 - IEEE Std 1733™-2011 (AVB RTP Extension), Talker and Listener
- Microphone
 - One on-board PDM microphone (Micro-Electro-Mechanical Systems (MEMS) technology)
 - Support for external analog microphone
- Audio codec providing:
 - One analog stereo input
 - One analog stereo output

1.2 FUNCTIONAL DESCRIPTION

Figure 1-2 shows a simplified block diagram of the EVB-LAN9360.

FIGURE 1-2: BLOCK DIAGRAM

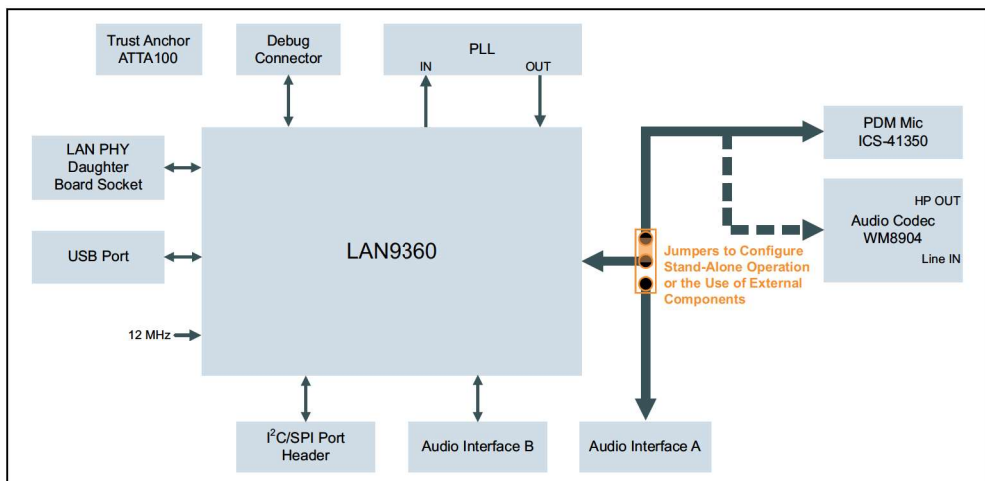

The EVB-LAN9360, assembled with a PDM microphone in MEMS technology and one stereo audio codec, can be used stand-alone to directly test or implement several configuration options (e.g., the board operates as a Talker and uses the Line In of the on-board codec).

Apart from the stand-alone use case, the board can be easily extended with customer components via on-board expansion connectors that allow external devices to be connected.

If the board should be run in stand-alone operation or if it uses external components can be configured by jumpers (simplified depicted in Figure 1-2; configuration details can be found in Figure A-1).

Chapter 2. PHY Daughter Board

As shown in [Figure 1-1](#), the EVB-LAN9360 is designed in a way that allows to easily exchange the Ethernet transceiver (PHY) and connector. For this purpose Microchip Technology Inc. provides LAN PHY daughter boards:

- For 100BASE-TX applications the LAN PHY daughter board uses a KSZ8041¹; for details refer to <https://www.microchip.com/Developmenttools/ProductDetails/AC320004-5>
- For 100BASE-T1 applications the LAN PHY daughter board uses a LAN8770 [1]; for details refer to <https://www.microchip.com/Developmenttools/ProductDetails/EV48S68A>
- For 10BASE-T1S applications please contact our [Customer Support](#)

LAN PHY daughter boards must be connected to the EVB-LAN9360 by use of J2-J5, see [Section 5.1](#).

Note: Connecting or changing LAN PHY daughter boards is only permitted when the device is detached from power. Hot plug is not supported and could damage the hardware.

Note: Repeated plugging and unplugging of LAN PHY daughter boards should be avoided due to the sensitivity of the connectors.

[Figure 2-1](#) shows some examples of available LAN PHY daughter boards.

FIGURE 2-1: LAN PHY DAUGHTER BOARD EXAMPLES

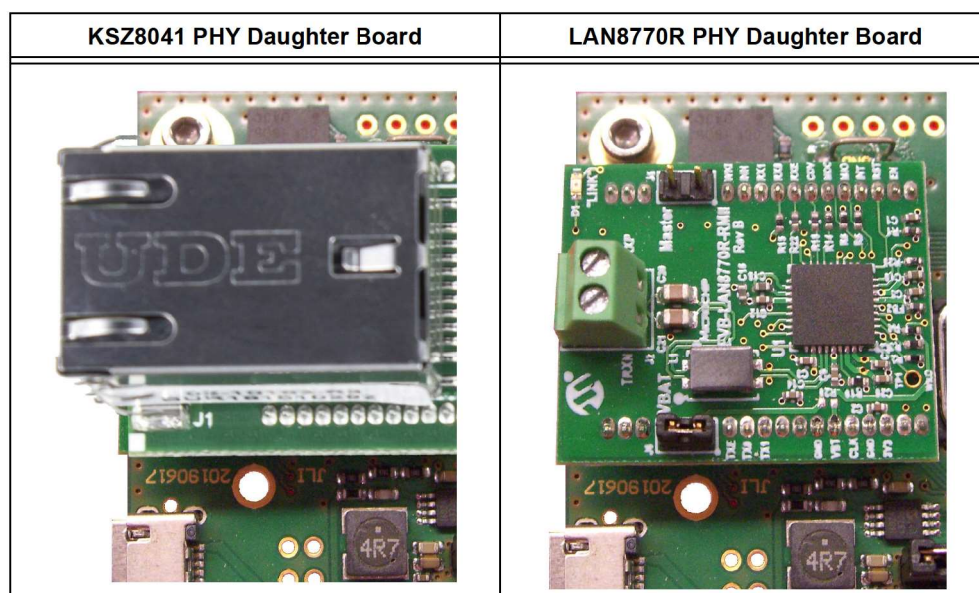

1. For custom designs, an automotive version “KSZ8051” is also available. For details refer to: <https://www.microchip.com/wwwproducts/en/KSZ8051>

EVB-LAN9360

NOTES:

Chapter 3. Board Details

3.1 ELECTRICAL CHARACTERISTICS

Parameter	Min.	Typ.	Max.	Unit
Board Current Consumption at Board Operating Voltage	—	—	300	mA
	4.5	5	5.5	V

3.2 CONNECTORS

3.2.1 CN1 and CN2 – Audio Sockets

These connectors are located on the top side of the board, see [Section 5.1](#).

CN1 is used as Headphone Out connector.

CN2 is used as Line In connector.

Designator	Socket Type
CN1	SJ-3524-SMT-TR-GR, standard jack, stereo, 3.5 mm, green, from CUI Inc.
CN2	SJ-3524-SMT-TR-BE, standard jack, stereo, 3.5 mm, blue, from CUI Inc.
Suitable counter-piece: SP-3501, stereo plug, 3.5 mm male, from CUI Inc.	

3.2.2 J1 – USB Connector

This connector is located on the top side of the board, see [Section 5.1](#).

Designator	Socket Type
J1	Standard type micro B
Suitable counter-piece: USB cable type A male/type micro B	

[Table 3-1](#) shows the pin assignment of J1.

TABLE 3-1: USB CONNECTOR – PIN ASSIGNMENT

Pin	Description
1	VBUS
2	D-
3	D+
4	NC
5, 6, 7, 8, 9	GND

3.2.3 J2-J5 – LAN PHY Daughter Board Connector

These connectors are located on the top side of the board, see [Section 5.1](#).

J2-J5 are used to attach a LAN PHY daughter board onto the EVB-LAN9360, see also [Chapter 2](#).

3.2.4 J26 – I2C/SPI Connector

This connector is located on the top side of the board, see [Section 5.1](#).

Designator	Socket Type
J26	612 010 235 121, 2x5 TH Header Shrouded 2.54 mm Pitch, from Würth Elektronik
Suitable counter-piece: WR-BHD	

[Table 3-2](#) shows the pin assignment of J26.

TABLE 3-2: I2C/SPI CONNECTOR – PIN ASSIGNMENT

Pin	Description
1	B-SCL
2, 10	GND
3	B-SDA
4, 6	3.3 V
5	MISO
7	SPI-CLK
8	MOSI
9	/PCS

3.2.5 J28 – Audio Interface A Connector

This connector is located on the top side of the board, see [Section 5.1](#).

J28 is used as serial synchronous controller interface. It serves as board extension for connecting external devices.

Designator	Socket Type
J28	TSW-107-07-G-D, 2.54 mm Pitch, from Samtec
Suitable counter-piece: SSW-107-01-G-D	

[Table 3-3](#) shows the pin assignment of J28.

TABLE 3-3: AUDIO INTERFACE A CONNECTOR – PIN ASSIGNMENT

Pin	Description
1, 3, 5, 7, 9, 11, 13	GND
2	3.3 V
4	CLKEN
6	A-MCLK
8	SCKA
10	FSYA
12	SRA
14	SXA

3.2.6 J29 – Audio Interface B Connector

This connector is located on the top side of the board, see [Section 5.1](#).

J29 is used as I²S interface. It serves as board extension for connecting external devices.

Designator	Socket Type
J29	TSW-109-07-G-D, 2.54 mm Pitch, from Samtec
Suitable counter-piece: SSW-109-07-G-D	

[Table 3-4](#) shows the pin assignment of J29.

TABLE 3-4: AUDIO INTERFACE B CONNECTOR – PIN ASSIGNMENT

Pin	Description
1, 3, 5, 7, 9, 11, 13, 15, 17	GND
2	3.3 V
4	CLKEN
6	A-MCLK
8	SCKB
10	FSYB
12	SRB
14	SXB
16	ext-SCL
18	ext-SDA

3.2.7 J30 – I2C/SPI Port Header

This port header can be accessed from the top and from the bottom side of the board. The location of the port header is visualized in [Figure 5-2](#).

Designator	Socket Type
J30	TSW-110-23-F-S, 2.54 mm Pitch, from Samtec
Suitable counter-piece: SSW-110-23-F-S	

[Table 3-5](#) shows the pin assignment of J30.

TABLE 3-5: I2C/SPI PORT HEADER – PIN ASSIGNMENT

Pin	Description
1	XP-SCL
2	XP-SDA
3	NC
4	GND
5	XP-SCK
6	XP-MISO
7	XP-MOSI
8	XP-SS
9	XP-FC
10	XP-Int0a

3.3 JUMPERS

All jumpers are located on the top side of the board, see [Section 5.1](#).

3.3.1 J10 – Power Management Option

If closed (1-2), this jumper connects to LAN-INH, using the LAN PHY daughter board power management.

If closed (2-3), the board is always powered.

Designator	Socket Type
J10	TSW-103-23-F-S, 2.54 mm TH SQ Header, from Samtec
Suitable counter-piece: Jumper 2.54 mm	

3.3.2 J11 – Reserved

Reserved for future use. Do not close the jumper.

Designator	Socket Type
J11	TSW-102-23-F-S, 2.54 mm TH SQ Header, from Samtec
Suitable counter-piece: Jumper 2.54 mm	

3.3.3 J12 – SCL Connector

If closed (1-2), this jumper connects SCL1 to J26, pin1.

If closed (2-3), this jumper connects SCL0 to J26, pin1.

Designator	Socket Type
J12	TSW-103-23-F-S, 2.54 mm TH SQ Header, from Samtec
Suitable counter-piece: Jumper 2.54 mm	

3.3.4 J13 – SDA Connector

If closed (1-2), this jumper connects SDA1 to J26, pin3.

If closed (2-3), this jumper connects SDA0 to J26, pin3.

Designator	Socket Type
J13	TSW-103-23-F-S, 2.54 mm TH SQ Header, from Samtec
Suitable counter-piece: Jumper 2.54 mm	

3.3.5 J14 – Select SPI

If closed (1-2), this jumper setting is for test purposes only and must not be used.

If closed (2-3), this jumper connects the SPI SPCK signal to the SPI Port Header.

Designator	Socket Type
J14	TSW-103-23-F-S, 2.54 mm TH SQ Header, from Samtec
Suitable counter-piece: Jumper 2.54 mm	

3.3.6 J15 – Connect AVB Endpoint PLLIN/RK

If closed (1-2), this jumper connects the AVB Endpoint PLLIN/RK to the PLL divider output.

If closed (2-3), this jumper connects the AVB Endpoint PLLIN/RK to Audio Interface A, pin 8.

Designator	Socket Type
J15	TSW-103-23-F-S, 2.54 mm TH SQ Header, from Samtec
Suitable counter-piece: Jumper 2.54 mm	

3.3.7 J16 – Connect AVB Endpoint SRA Audio Interface A

If closed (1-2), this jumper connects the AVB Endpoint SRA Audio Interface A to the microphone.

If closed (2-3), this jumper connects the AVB Endpoint SRA Audio Interface A to the audio codec.

Designator	Socket Type
J16	TSW-103-23-F-S, 2.54 mm TH SQ Header, from Samtec
Suitable counter-piece: Jumper 2.54 mm	

3.3.8 J17 – Connect Microphone Clock to the AVB Endpoint

If closed (1-2), this jumper connects the microphone clock CLK to the AVB Endpoint.

Designator	Socket Type
J17	TSW-102-23-F-S, 2.54 mm TH SQ Header, from Samtec
Suitable counter-piece: Jumper 2.54 mm	

3.3.9 J18 – Connect Audio Codec Clock to the AVB Endpoint

If closed (1-2), this jumper connects the audio codec clock BCKL to the AVB Endpoint.

Designator	Socket Type
J18	TSW-102-23-F-S, 2.54 mm TH SQ Header, from Samtec
Suitable counter-piece: Jumper 2.54 mm	

3.3.10 J19 – Connect Audio Codec DAC to the AVB Endpoint

If closed (1-2), this jumper connects the audio codec DAC to the AVB Endpoint.

Designator	Socket Type
J19	TSW-102-23-F-S, 2.54 mm TH SQ Header, from Samtec
Suitable counter-piece: Jumper 2.54 mm	

3.3.11 J20 – Connect Audio Codec LRCLK to the AVB Endpoint

If closed (1-2), this jumper connects the audio codec LRCLK to the AVB Endpoint.

Designator	Socket Type
J20	TSW-102-23-F-S, 2.54 mm TH SQ Header, from Samtec
Suitable counter-piece: Jumper 2.54 mm	

3.3.12 J21 – Connect AVB Endpoint RF with AVB Endpoint EVIN

If closed (1-2), this jumper connects the AVB Endpoint RF signal with the AVB Endpoint EVIN signal.

Designator	Socket Type
J21	TSW-102-23-F-S, 2.54 mm TH SQ Header, from Samtec
Suitable counter-piece: Jumper 2.54 mm	

3.3.13 J22 – Erase Flash Memory of AVB Endpoint

If closed, this jumper is used to erase the flash memory of the AVB Endpoint.

Designator	Socket Type
J22	TSW-102-23-F-S, 2.54 mm TH SQ Header, from Samtec
Suitable counter-piece: Jumper 2.54 mm	

3.3.14 J23 – Enable External Power for Analog Microphone

If closed, this jumper is used to enable external power for an analog microphone.

Designator	Socket Type
J23	TSW-102-23-F-S, 2.54 mm TH SQ Header, from Samtec
Suitable counter-piece: Jumper 2.54 mm	

3.4 BUTTONS

All buttons are located on the top side of the board, see [Section 5.1](#).

Designator	Description
Button0 (SW1)	Reserved for future use.
Button1 (SW2)	
Reset (SW3)	Reset components on the development board, especially the LAN9360
Wake (SW4)	Wake up PHY daughter board (WakeIN signal)

3.5 LEDS

LEDs 0-2 are mounted on the top side of the board (see [Section 5.1](#)); LED 120 is mounted on the bottom side (see [Section 5.2](#)).

The table below gives an overview of the LEDs and the states they signal.

Designator	State	Description
LED0 (LD1)	Off	Reserved for future use
	On (red)	
LED1 (LD2)	Off	
	On (yellow)	
UNL (LD3)	Off	Media Clock unlock indicator
	On (green)	Media Clock lock indicator
LED120 (LD120)	Off	PLL lock indicator
	On (red)	PLL unlock indicator, depends on firmware

EVB-LAN9360

NOTES:

Chapter 4. Configuration Options

This chapter lists several configuration options that can be setup with the EVB-LAN9360. Possible configuration options are as follows:

- [Listener and/or Talker with On-Board Codec](#)
- [Listener and/or Talker with External Codec/DSP](#)
- [Talker with On-Board MEMS Mic \(PDM\) and Listener with On-Board Codec](#)
- [Talker with On-Board MEMS Mic \(PDM\) and Listener with External Sink](#)
- [Talker with External PCM Source and Listener with On-Board Codec](#)
- [1PPS Method for Clock Accuracy Measurement](#)

Common jumper settings

For all configuration options, the following jumper settings are common:

TABLE 4-1: COMMON JUMPER SETTINGS

Jumper	Setting
J10	2-3
J12	1-2
J13	
J14	2-3
J15	1-2
J21	Open

Deviating jumper settings are described in the respective configuration sections, see the following pages.

Codec

The on-board codec is configured by the LAN9360 via I²C.

Note: The configuration of an external codec is not included in the LAN9360's functionality.

Media clock generation

For media clock generation the following conditions apply:

- If an on-board source or sink is used, the media clock (FSY, SCK) is generated by the LAN9360.
- If a MEMS microphone (PDM), either on-board or external is used, the media clock (FSY, SCK) is generated by the LAN9360.
- If an external source or sink (codec, DSP) is used, the media clock can either be provided externally or is generated by the LAN9360.

EVB-LAN9360

4.1 LISTENER AND/OR TALKER WITH ON-BOARD CODEC

In this configuration the LAN9360 acts as Talker or Listener or both. The on-board codec is used as PCM source and sink.

This configuration is the factory default configuration.

Table 4-2 gives an overview of the jumper settings for this configuration.

TABLE 4-2: LISTENER AND/OR TALKER WITH ON-BOARD CODEC – JUMPER SETTINGS

Jumper	Setting
J16	2-3
J17	Open
J18	1-2
J19	
J20	

Figure 4-1 depicts the jumper settings on the EVB-LAN9360.

FIGURE 4-1: LISTENER AND/OR TALKER WITH ON-BOARD CODEC – JUMPER SETTINGS

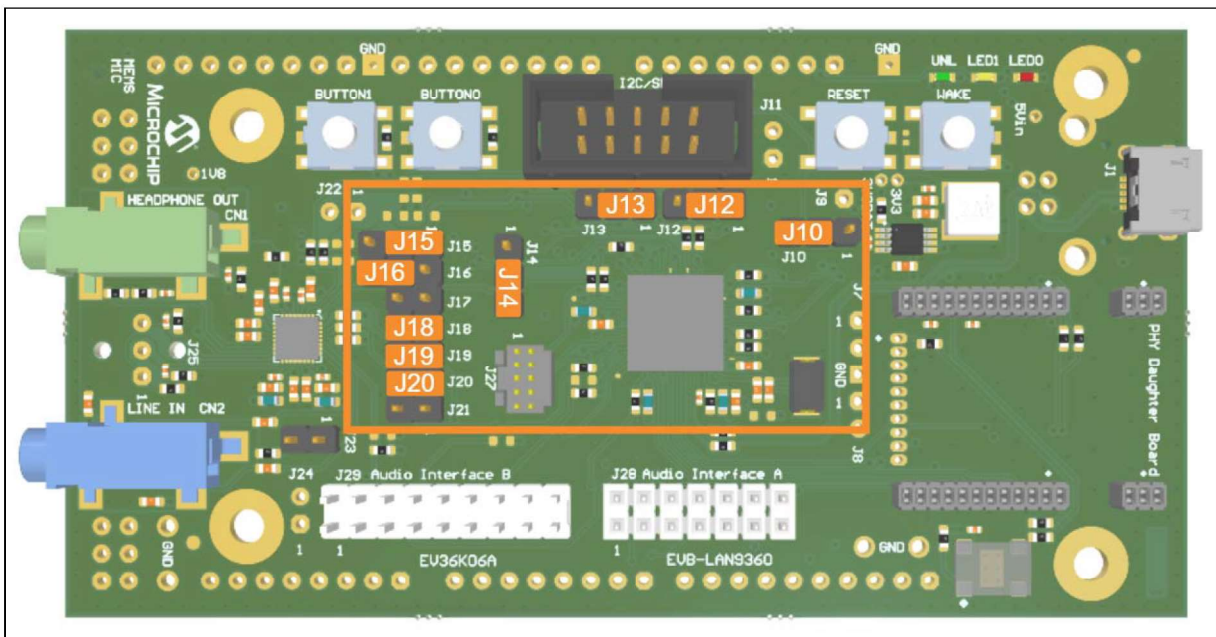

The audio source (stereo) for the AVB Talker is the blue jack connector (Line In).

Note: It is not possible to directly connect an analog microphone (no power feed).

The AVB Listener plays the received audio signal (stereo) through the green jack connector (Headphone Out).

4.2 LISTENER AND/OR TALKER WITH EXTERNAL CODEC/DSP

In this configuration the LAN9360 acts as Talker or Listener or both. An external codec or DSP is connected to the Audio Interface A Connector (J28, see [Section 3.2.5](#)) as PCM source and sink.

Note: It is not possible to use the on-board codec simultaneously.

Table 4-3 gives an overview of the jumper settings for this configuration.

TABLE 4-3: LISTENER AND/OR TALKER WITH EXTERNAL CODEC/DSP – JUMPER SETTINGS

Jumper	Setting
J16	Open
J17	
J18	
J19	
J20	

Figure 4-2 depicts the jumper settings on the EVB-LAN9360.

FIGURE 4-2: LISTENER AND/OR TALKER WITH EXTERNAL CODEC/DSP – JUMPER SETTINGS

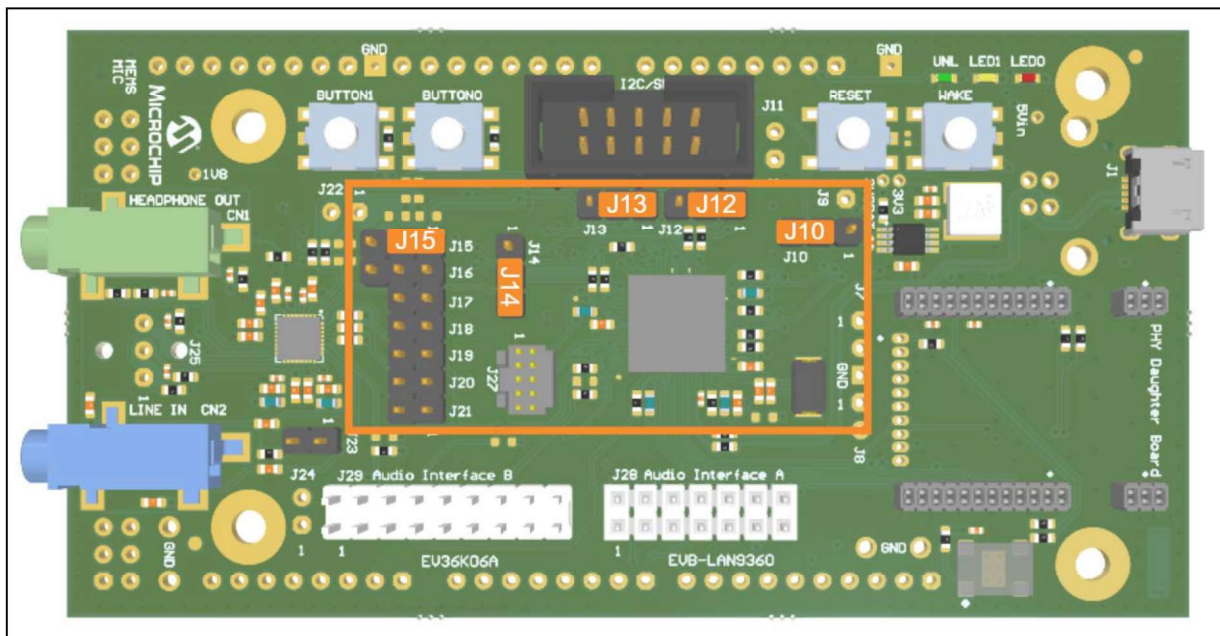

The audio source for the AVB Talker and the audio sink for the AVB Listener is provided at Audio Interface A.

EVB-LAN9360

4.3 TALKER WITH ON-BOARD MEMS MIC (PDM) AND LISTENER WITH ON-BOARD CODEC

In this configuration the LAN9360 acts as Talker. The on-board MEMS microphone is used as PDM source. In addition, the LAN9360 may act as Listener. The on-board codec is used as PCM sink.

Table 4-4 gives an overview of the jumper settings for this configuration.

TABLE 4-4: TALKER WITH ON-BOARD MEMS MIC (PDM) AND LISTENER WITH ON-BOARD CODEC – JUMPER SETTINGS

Jumper	Setting
J16	1-2
J17	
J18	
J19	
J20	

Figure 4-3 depicts the jumper settings on the EVB-LAN9360.

FIGURE 4-3: TALKER WITH ON-BOARD MEMS MIC (PDM) AND LISTENER WITH ON-BOARD CODEC – JUMPER SETTINGS

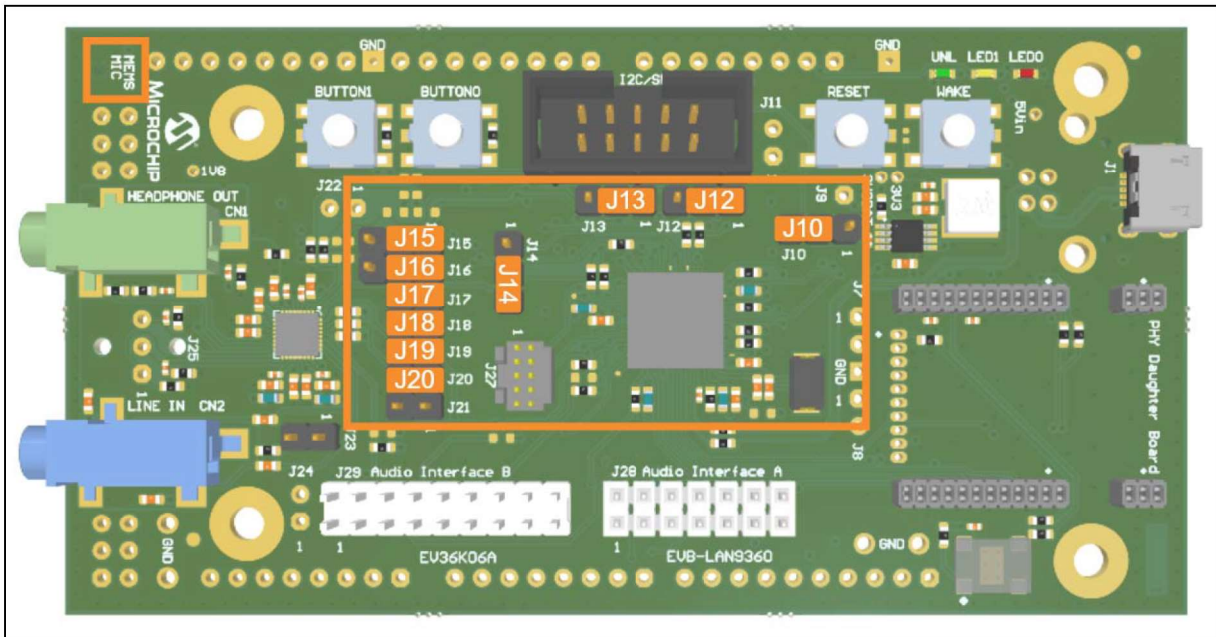

The audio source (mono) for the AVB Talker is the on-board MEMS microphone ICS-41350 as shown in Figure 4-3 (upper left corner).

The AVB Listener plays the received audio signal (stereo) through the green jack connector (Headphone Out).

4.4 TALKER WITH ON-BOARD MEMS MIC (PDM) AND LISTENER WITH EXTERNAL SINK

In this configuration the LAN9360 acts as Talker and Listener. The on-board MEMS microphone is used as PDM source. An external codec/DSP is connected to the Audio Interface A Connector (J28, see [Section 3.2.5](#)) as PCM sink.

[Table 4-5](#) gives an overview of the jumper settings for this configuration.

TABLE 4-5: TALKER WITH ON-BOARD MEMS MIC (PDM) AND LISTENER WITH EXTERNAL SINK – JUMPER SETTINGS

Jumper	Setting
J16	1-2
J17	
J18	Open
J19	
J20	

[Figure 4-4](#) depicts the jumper settings on the EVB-LAN9360.

FIGURE 4-4: TALKER WITH ON-BOARD MEMS MIC (PDM) AND LISTENER WITH EXTERNAL SINK – JUMPER SETTINGS

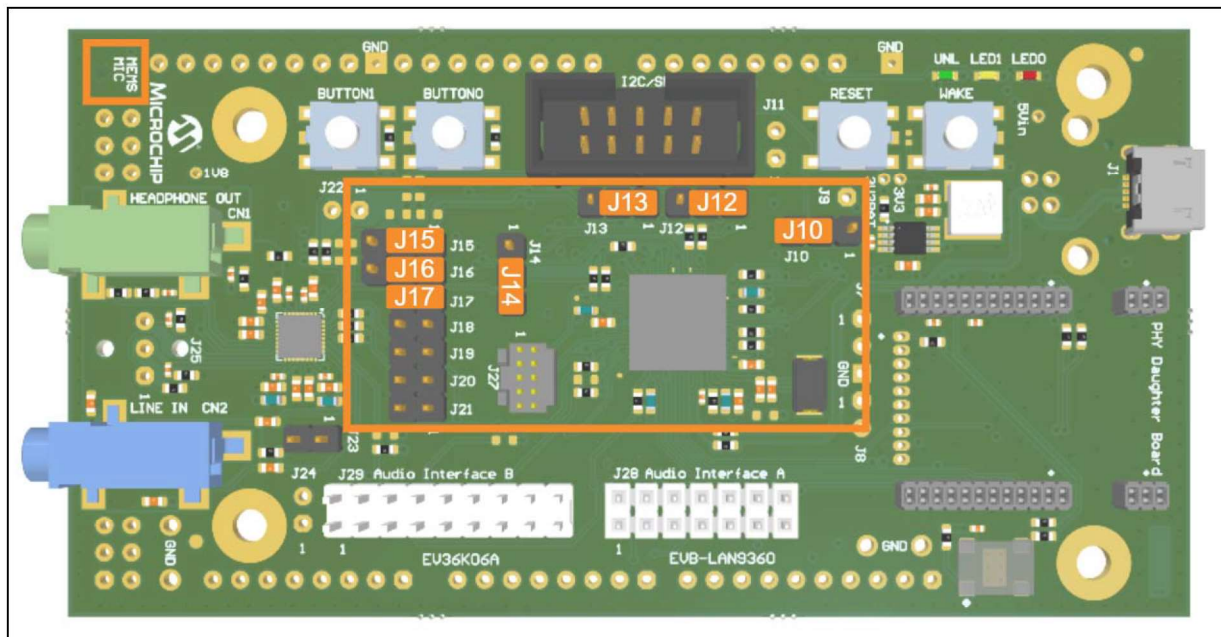

The audio source (mono) for the AVB Talker is the on-board MEMS microphone ICS-41350 as shown in [Figure 4-4](#) (upper left corner).

The audio sink for the AVB Listener is provided at Audio Interface A.

EVB-LAN9360

4.5 TALKER WITH EXTERNAL PCM SOURCE AND LISTENER WITH ON-BOARD CODEC

In this configuration the LAN9360 acts as Talker and Listener. An external codec/DSP is connected to Audio Interface A (J28, see [Section 3.2.5](#)) as PCM source. The on-board codec is used as PCM sink.

[Table 4-6](#) gives an overview of the jumper settings for this configuration.

TABLE 4-6: TALKER WITH EXTERNAL PCM SOURCE AND LISTENER WITH ON-BOARD CODEC – JUMPER SETTINGS

Jumper	Setting
J16	Open
J17	
J18	1-2
J19	
J20	
J20	

[Figure 4-5](#) depicts the jumper settings on the EVB-LAN9360.

FIGURE 4-5: TALKER WITH EXTERNAL PCM SOURCE AND LISTENER WITH ON-BOARD CODEC – JUMPER SETTINGS

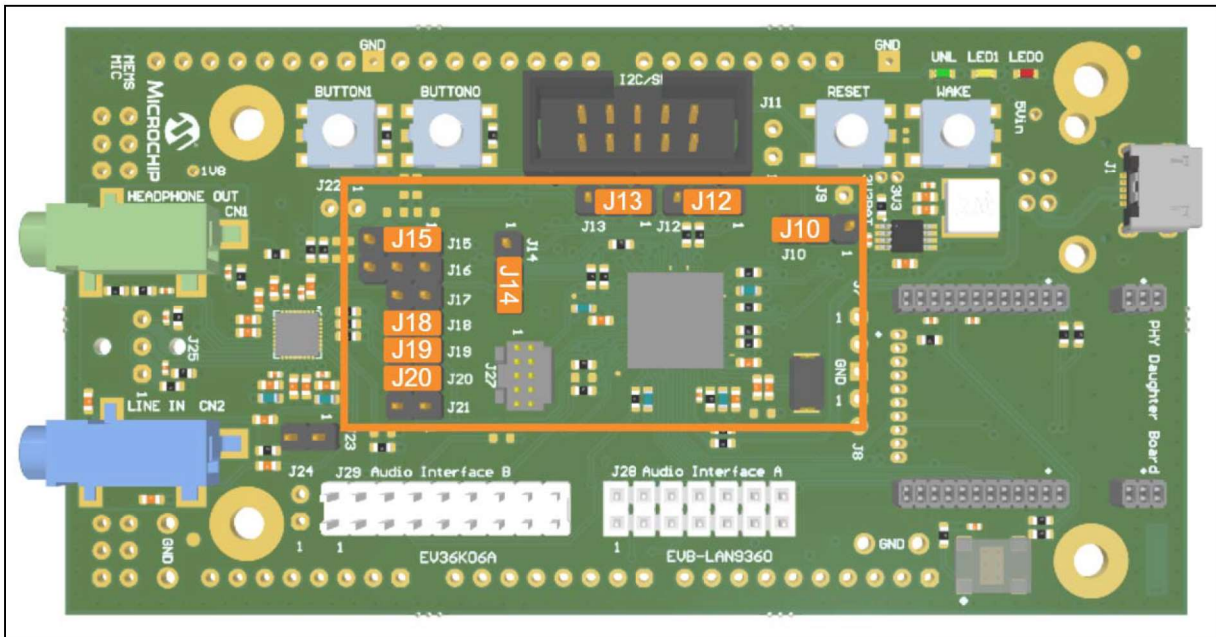

The audio source for the AVB Talker is provided at Audio Interface A. The AVB Listener plays the received audio signal (stereo) through the green jack connector (Headphone Out).

4.6 1PPS METHOD FOR CLOCK ACCURACY MEASUREMENT

In this configuration the LAN9360 does not process audio data, neither as a Talker nor as a Listener—hence, jumper settings are not required.

A one-pulse-per-second (1PPS) signal is provided at J9 to measure the accuracy of the synchronization to the gPTP clock. The device may operate as gPTP master or gPTP slave. Reception of a media clock is not required and has no influence on the 1PPS signal.

Figure 4-6 indicates the location of J9 on the LAN9360 Development Board.

FIGURE 4-6: 1PPS METHOD FOR CLOCK ACCURACY MEASUREMENT – J9

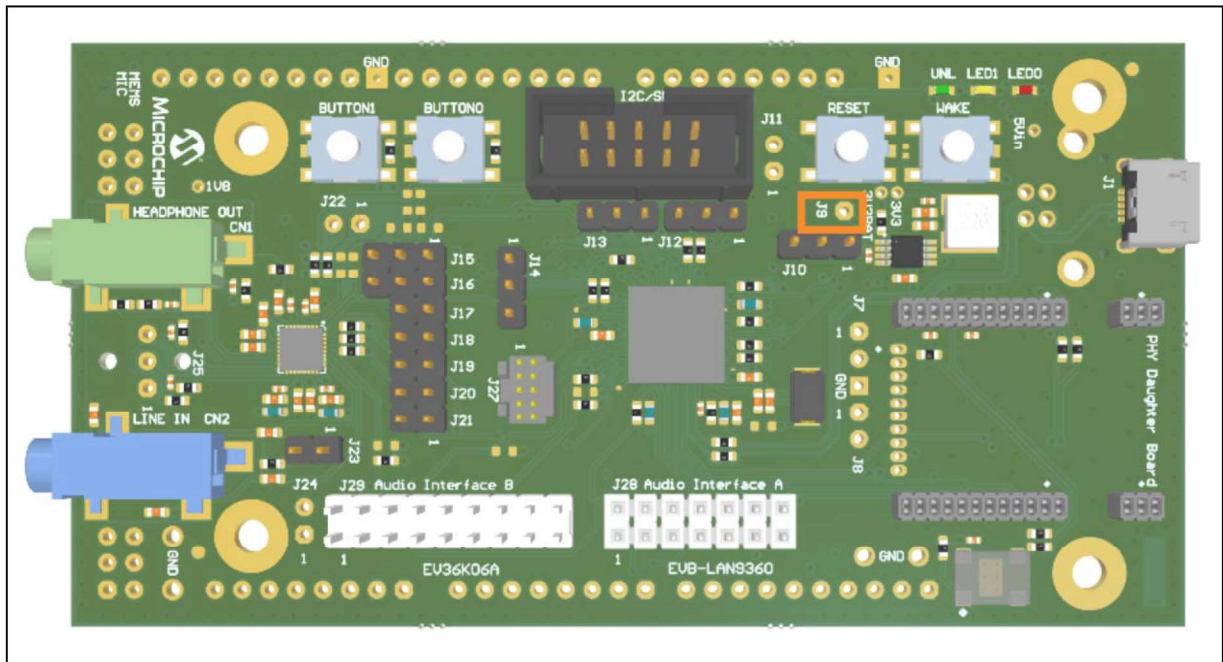

To evaluate the 1PPS signal, an oscilloscope can be connected to J9. However, the most accurate measurement can be obtained by connecting the oscilloscope between the mono flop and the resistor that goes to LAN9360 ball F8 (REFCLK0 signal), see Figure A-1.

It is of advantage to compare the 1PPS signals with multiple devices (gPTP master with several gPTP slaves).

EVB-LAN9360

NOTES:

Chapter 5. Assembly Plan and Mechanical Dimensions

5.1 TOP VIEW AND MECHANICAL DIMENSIONS

FIGURE 5-1: ASSEMBLY PLAN – TOP VIEW AND MECHANICAL DIMENSIONS

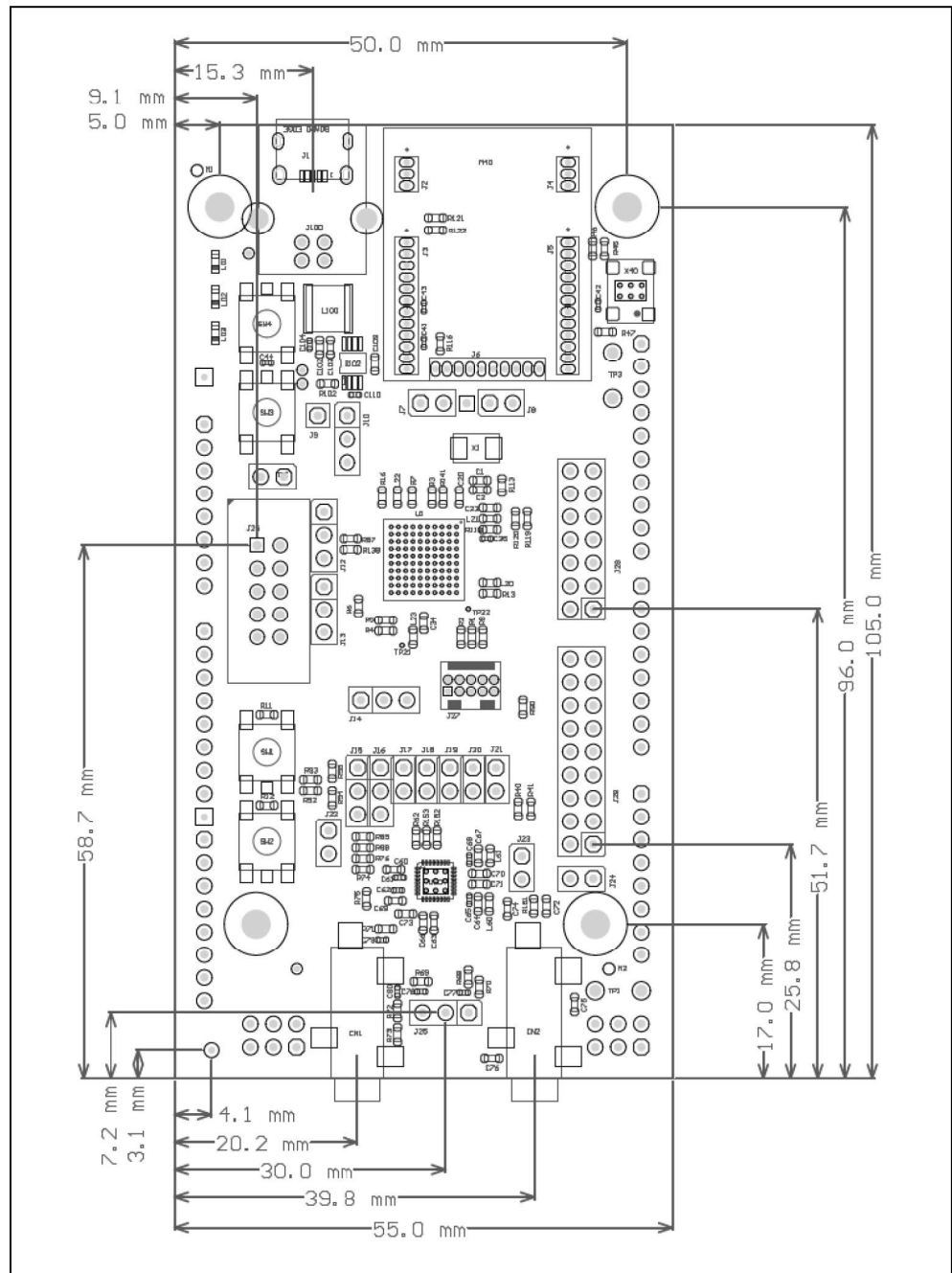

5.2 BOTTOM VIEW AND MECHANICAL DIMENSIONS

FIGURE 5-2: ASSEMBLY PLAN – BOTTOM VIEW AND MECHANICAL DIMENSIONS

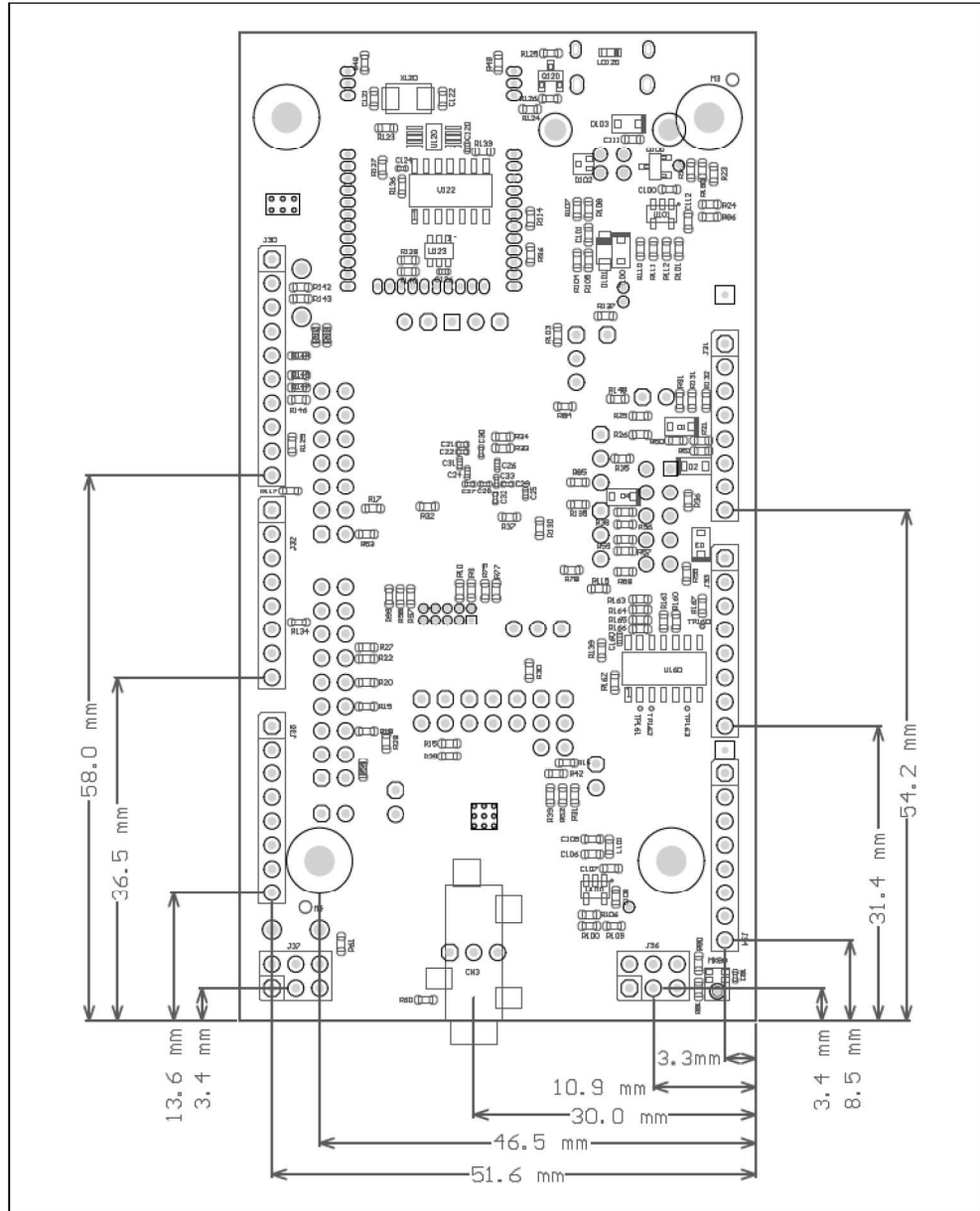

Appendix A. AVB Endpoint Connection Options

Figure A-1 shows a simple block diagram of the EVB-LAN9360 including the AVB Endpoint connection options configurable by jumpers.

Note: Pin 1 of each jumper is indicated by a square.

For a description of the jumpers refer to [Section 3.3](#).

FIGURE A-1: AVB ENDPOINT CONNECTION OPTIONS

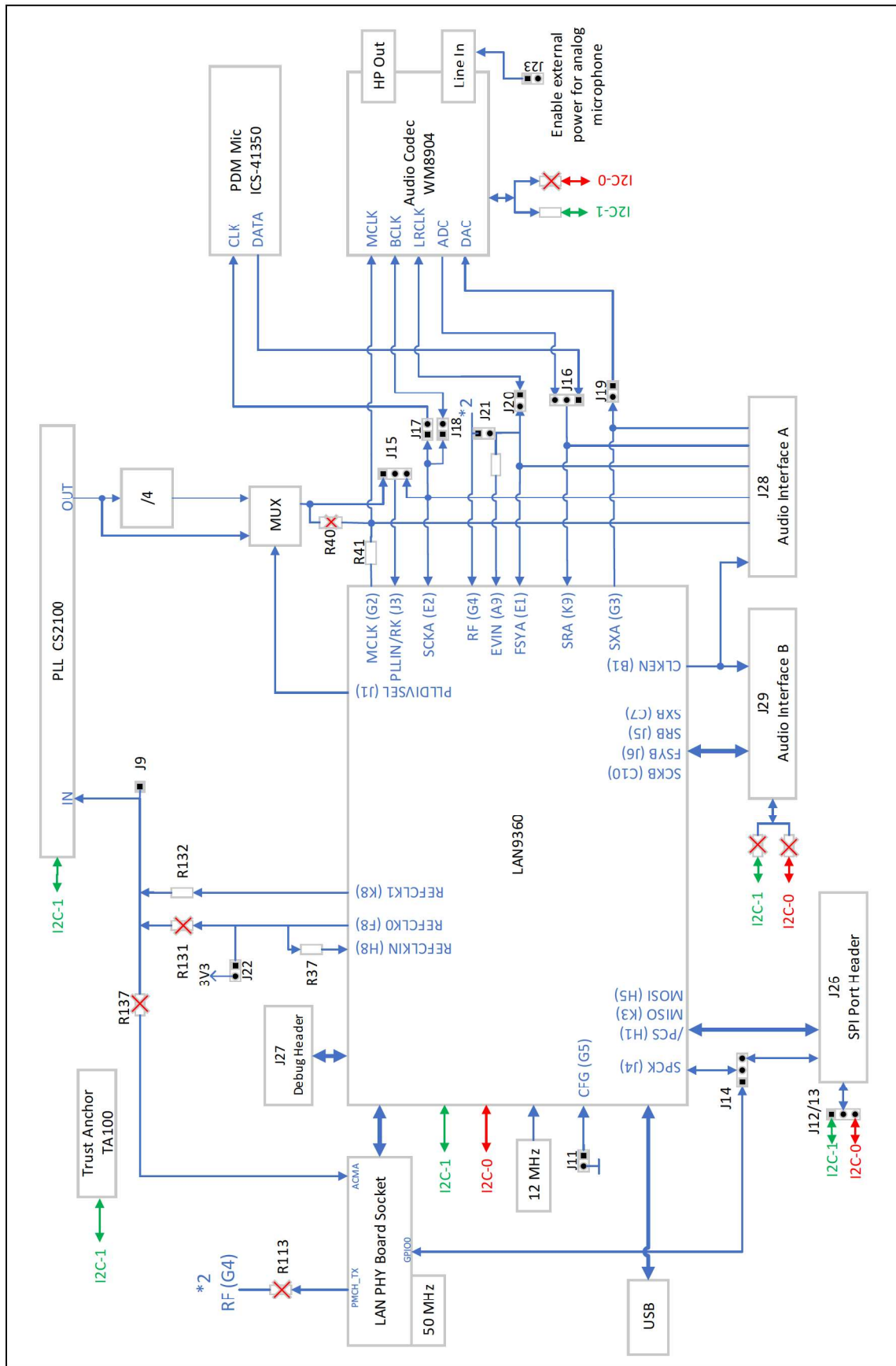

List of Figures

Figure 1-1: EVB-LAN9360	9
Figure 1-2: Block Diagram	10
Figure 2-1: LAN PHY Daughter Board Examples	11
Figure 4-1: Listener and/or Talker with On-Board Codec – Jumper Settings	24
Figure 4-2: Listener and/or Talker with External Codec/DSP – Jumper Settings	25
Figure 4-3: Talker with On-Board MEMS Mic (PDM) and Listener with On-Board Codec – Jumper Settings	26
Figure 4-4: Talker with On-Board MEMS Mic (PDM) and Listener with External Sink – Jumper Settings	27
Figure 4-5: Talker with External PCM Source and Listener with On-Board Codec – Jumper Settings	28
Figure 4-6: 1PPS Method for Clock Accuracy Measurement – J9	29
Figure 5-1: Assembly Plan – Top View and Mechanical Dimensions	31
Figure 5-2: Assembly Plan – Bottom View and Mechanical Dimensions	32
Figure A-1: AVB Endpoint Connection Options	34

EVB-LAN9360

NOTES:

List of Tables

Table 3-1: USB Connector – Pin Assignment	13
Table 3-2: I2C/SPI Connector – Pin Assignment	14
Table 3-3: Audio Interface A Connector – Pin Assignment	15
Table 3-4: Audio Interface B Connector – Pin Assignment	16
Table 3-5: I2C/SPI Port Header – Pin Assignment	17
Table 4-1: Common Jumper Settings	23
Table 4-2: Listener and/or Talker with On-Board Codec – Jumper Settings	24
Table 4-3: Listener and/or Talker with External Codec/DSP – Jumper Settings	25
Table 4-4: Talker with On-Board MEMS Mic (PDM) and Listener with On-Board Codec – Jumper Settings	26
Table 4-5: Talker with On-Board MEMS Mic (PDM) and Listener with External Sink – Jumper Settings	27
Table 4-6: Talker with External PCM Source and Listener with On-Board Codec – Jumper Settings	28



MICROCHIP

Worldwide Sales and Service

AMERICAS

Corporate Office
2355 West Chandler Blvd.
Chandler, AZ 85224-6199
Tel: 480-792-7200
Fax: 480-792-7277
Technical Support:
[http://www.microchip.com/
support](http://www.microchip.com/support)
Web Address:
www.microchip.com

Atlanta

Duluth, GA
Tel: 678-957-9614
Fax: 678-957-1455

Austin, TX

Tel: 512-257-3370

Boston

Westborough, MA
Tel: 774-760-0087
Fax: 774-760-0088

Chicago

Itasca, IL
Tel: 630-285-0071
Fax: 630-285-0075

Dallas

Addison, TX
Tel: 972-818-7423
Fax: 972-818-2924

Detroit

Novi, MI
Tel: 248-848-4000

Houston, TX

Tel: 281-894-5983

Indianapolis

Noblesville, IN
Tel: 317-773-8323
Fax: 317-773-5453
Tel: 317-536-2380

Los Angeles

Mission Viejo, CA
Tel: 949-462-9523
Fax: 949-462-9608
Tel: 951-273-7800

Raleigh, NC

Tel: 919-844-7510

New York, NY

Tel: 631-435-6000

San Jose, CA

Tel: 408-735-9110
Tel: 408-436-4270

Canada - Toronto

Tel: 905-695-1980
Fax: 905-695-2078

ASIA/PACIFIC

Australia - Sydney
Tel: 61-2-9868-6733

China - Beijing
Tel: 86-10-8569-7000

China - Chengdu
Tel: 86-28-8665-5511

China - Chongqing
Tel: 86-23-8980-9588

China - Dongguan
Tel: 86-769-8702-9880

China - Guangzhou
Tel: 86-20-8755-8029

China - Hangzhou
Tel: 86-571-8792-8115

China - Hong Kong SAR
Tel: 852-2943-5100

China - Nanjing
Tel: 86-25-8473-2460

China - Qingdao
Tel: 86-532-8502-7355

China - Shanghai
Tel: 86-21-3326-8000

China - Shenyang
Tel: 86-24-2334-2829

China - Shenzhen
Tel: 86-755-8864-2200

China - Suzhou
Tel: 86-186-6233-1526

China - Wuhan
Tel: 86-27-5980-5300

China - Xian
Tel: 86-29-8833-7252

China - Xiamen
Tel: 86-592-2388138

China - Zhuhai
Tel: 86-756-3210040

ASIA/PACIFIC

India - Bangalore
Tel: 91-80-3090-4444

India - New Delhi
Tel: 91-11-4160-8631

India - Pune
Tel: 91-20-4121-0141

Japan - Osaka
Tel: 81-6-6152-7160

Japan - Tokyo
Tel: 81-3-6880-3770

Korea - Daegu
Tel: 82-53-744-4301

Korea - Seoul
Tel: 82-2-554-7200

Malaysia - Kuala Lumpur
Tel: 60-3-7651-7906

Malaysia - Penang
Tel: 60-4-227-8870

Philippines - Manila
Tel: 63-2-634-9065

Singapore
Tel: 65-6334-8870

Taiwan - Hsin Chu
Tel: 886-3-577-8366

Taiwan - Kaohsiung
Tel: 886-7-213-7830

Taiwan - Taipei
Tel: 886-2-2508-8600

Thailand - Bangkok
Tel: 66-2-694-1351

Vietnam - Ho Chi Minh
Tel: 84-28-5448-2100

EUROPE

Austria - Wels
Tel: 43-7242-2244-39
Fax: 43-7242-2244-393

Denmark - Copenhagen
Tel: 45-4485-5910
Fax: 45-4485-2829

Finland - Espoo
Tel: 358-9-4520-820

France - Paris
Tel: 33-1-69-53-63-20
Fax: 33-1-69-30-90-79

Germany - Garching
Tel: 49-8931-9700

Germany - Haan
Tel: 49-2129-3766400

Germany - Heilbronn
Tel: 49-7131-72400

Germany - Karlsruhe
Tel: 49-721-625370

Germany - Munich
Tel: 49-89-627-144-0
Fax: 49-89-627-144-44

Germany - Rosenheim
Tel: 49-8031-354-560

Israel - Ra'anana
Tel: 972-9-744-7705

Italy - Milan
Tel: 39-0331-742611
Fax: 39-0331-466781

Italy - Padova
Tel: 39-049-7625286

Netherlands - Drunen
Tel: 31-416-690399
Fax: 31-416-690340

Norway - Trondheim
Tel: 47-7288-4388

Poland - Warsaw
Tel: 48-22-3325737

Romania - Bucharest
Tel: 40-21-407-87-50

Spain - Madrid
Tel: 34-91-708-08-90
Fax: 34-91-708-08-91

Sweden - Gothenberg
Tel: 46-31-704-60-40

Sweden - Stockholm
Tel: 46-8-5090-4654

UK - Wokingham
Tel: 44-118-921-5800
Fax: 44-118-921-5820