

Smart Radio Telemetry Modules

Features

- Embedded Remote Control
- 4 input / output Channels
- Range up to 2KM
- Serial Data output
- Minimal external components
- Secure data protocol
- Ultra low power 1.8 - 3.6V
- 2 Easy pairing options
- +15dBm Transmit power
- -121dBm Receive Sensitivity
- SMT or SIL package
- CE compliant
- Incorporates self test mode

4 Digital
Inputs



2000m



Serial/
4 Digital
Outputs



Applications

- Sensors
- I/O Telemetry devices
- Remote switching
- Remote traffic lights

Description

The ZPT modules provide an easy “plug and Play” Remote Control Telemetry system for any embedded application. The outputs at the receiver will follow the status of the inputs at the transmitter.

These modules are compatible with many RF Solutions Transmitters and Receivers and can be combined together to provide many different Remote Control options. The ZPT modules provide a small low power SMT/ DIL device with 4 digital inputs / outputs. Offering a versatile secure radio Telemetry system for many applications.

Transmitter Pin-out

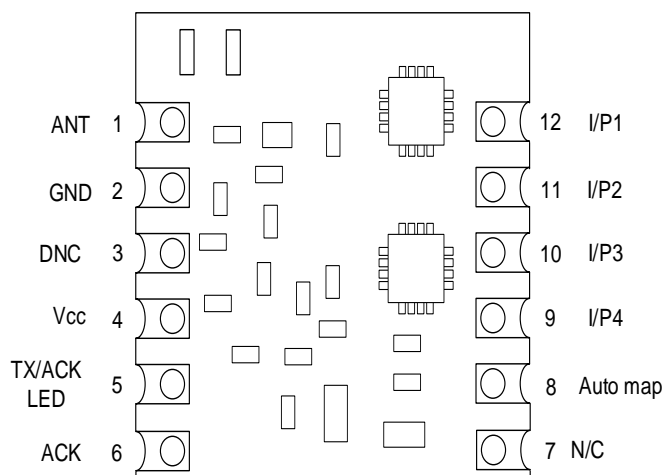

Pin Description

Pin No	Name	Direction	Description
1	ANT	In	Antenna input/output 50ohm impedance
2	GND	In	Connect to ground
3	N/C	NA	Do Not Connect on TX
4	Vcc	In	Supply voltage
5	TX/ACK LED	Out	On TX/Acknowledge LED active LOW
6	TX ACK Link	In	Acknowledge Request : Requests an acknowledgment from the ZPT receiver after each RF Transmission. This is Active low. Note: this input has internal pull-up and can be left disconnected if not required
7	N/C	-	No Connect
8	AUTOMAP	In	Active high. When active receiver will automap ZPT Transmitter inputs 1-4 to ZPT Receiver outputs 1-4 Note: this input has internal pull-up and can be left disconnected if not required
9-12	I/P1-4	In	Inputs are LVTTTL / LVCMOS at Vcc. Active Low. Note: Inputs have internal pull-up and can be left disconnected if not required

Ordering Information

Part No	Description
ZPT-4TD	Transmitter module DIL package 433MHz
ZPT-4TS	Transmitter module SMT package 433MHz
ZPT-8TD	Transmitter module DIL package 868MHz
ZPT-8TS	Transmitter module SMT package 868MHz

ZPT Transmitter Description

Each ZPT Transmitter has a unique identity (one of 16 billion possible numbers), the identity number transmitted on each press of the switch. Receivers can learn the identity of up to transmitters individual inputs and operate their individual outputs accordingly.

Note: The same transmitter may be taught to any number of receivers to create 'master keys'.

Transmitter Operation

The ZPT Transmitter module will remain in a low power mode at all times when power is present and no inputs are active.

When an input changes state, (high to low or low to high) the ZPT Transmitter will send an RF transmission.

Depending on the status of the "Acknowledgement Request" will define the RF Transmission(s).

Transmitter Operation without Acknowledgment request

On each state change of the input ZPT Transmitter will transmit a single RF "packet".

Transmitter Operation with Acknowledgment request

The RF Transmission "packet" is repeated a maximum of 5 times. This can be seen as LED intermittent flashes approx. every 200mSecs.

The ZPT Receiver will automatically reply with an RF acknowledgment signal.

On receiving and acknowledgement, the ZPT transmitter will then stop sending any further RF Transmissions until the next input state change.

After 5 RF transmission packets, if there is no acknowledgement received the ZPT transmitter will flash the LED at a high speed flicker for approx. 1 second.

Transmitter Input Asserted to

When an input pin is asserted the Module will immediately perform the following:

1. Wait for the asserted input to stabilise (no noise) for ≥ 2 mSecs
2. Proceed to transmit an RF packet to the receiver.

TX AUTOMAP

When AUTOMAP is activate all ZPT Receiver Outputs 1-4 are automatically mapped to ZPT transmitter inputs 1-4 from a single learn process.

This consumes a single memory space of the receivers max capacity of 30 ZPT Transmitters.

When AUTOMAP is not activate any ZPT Transmitter input can be paired to any one or many ZPT Receivers output(s).

Each input to output pairing will consume a memory space of the receivers max capacity of 30.

ZPT Telemetry Modules



ZPT Transmitter example application circuit

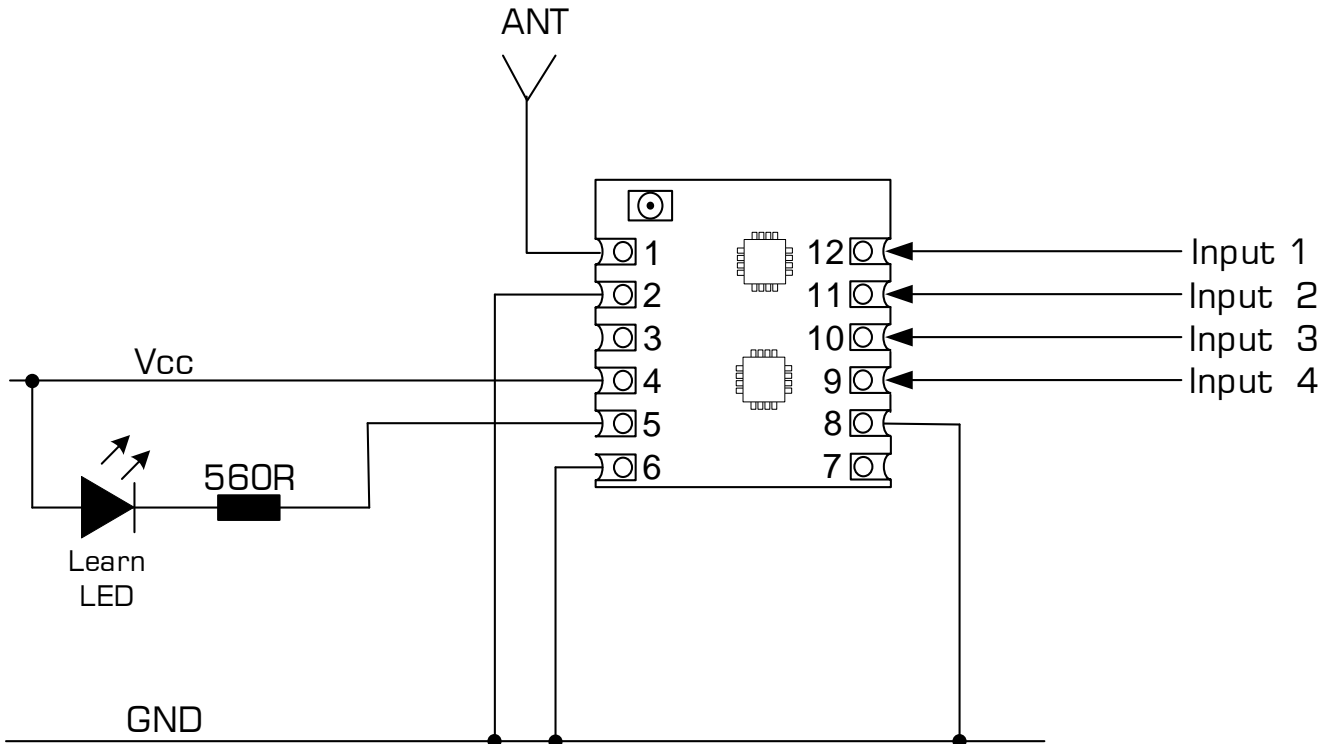

Note: In this example AUTOMAP feature is not used and Acknowledge is requested from the receiver.

ZPT Transmitter LED Output Status

Acknowledge request Active	
LED	Description
OFF	No RF data is being transmitted
Flash once every 200mSecs	The module is transmitting an RF transmission packet. The RF Transmission will be repeated until either; 1. An acknowledgment from the ZPT Receiver is received 2. Five packets have been transmitted
High speed flash for 1 sec	No Acknowledgement receiver

Acknowledge request NOT Active	
LED	Description
OFF	No RF data is being transmitted
Flash once	The module is transmitting an RF transmission packet.

Receiver Pin-out

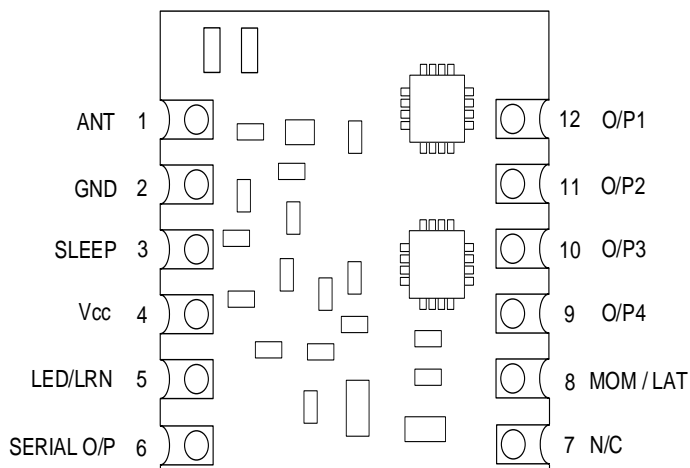

Pin Description

Pin No	Name	Direction	Description
1	ANT	In	Antenna input/output 50ohm impedance
2	GND	In	Supply Ground
3	SLEEP	In	Connect to Vcc, Module Enters SLEEP Connect to GND, Normal Operation
4	Vcc	In	Supply Voltage
5	LED/LRN	Out/In	Learn switch input and LED output Learn switch input: normally 'high' momentarily connect to GND to enter Learn Mode.
6	SERIAL O/P	Out	Serial Data output to Host micro
7	N/C	-	No Connect
8	MOM/LATCH	In	Set outputs as momentary or latching operation. Connect to GND for momentary Leave open for latching (Internally tied high) This input is read on power on only.
9-12	O/P1-4	Out	Digital Outputs

Ordering Information

Part No	Description
ZPT-4RD	Receiver module DIL package 433MHz
ZPT-4RS	Receiver module SMT package 433MHz
ZPT-8RD	Receiver module DIL package 868MHz
ZPT-8RS	Receiver module SMT package 868MHz

Receiver Operation

The ZPT module will remain in a low power listening mode at all times when power is present and the Sleep Input is Low. When a valid RF signal is received ZPT will wake and process the RF packet, activate its output(s), and acknowledge accordingly.

The ZPT Receiver will **always** output a valid data from any ZPT Transmitter on the Serial data output whether the ZPT Transmitter is paired or not paired.

Pairing Process

This process creates a relationship between ZPT Receiver digital output(s) and ZPT Transmitter input(s) so that when the ZPT Transmitter input is activated the ZPT receiver digital output will be activated according to its configuration setting.

1. Briefly connect LEARN pin5 to GND, LED will flash once indicating ready to pair output 1.
2. Repeat Briefly connect LEARN pin5 to GND, LED will flash twice indicating ready to pair output 2.
3. Repeat this for outputs 3 and 4.....
4. With the desired output selected (and before a 10sec timeout).
5. Press the chosen input on the ZPT transmitter to be paired.
6. ZPT Receiver will flash its LED twice to confirm pairing is complete.

Notes:

1. ZPT Receiver will automatically Timeout and exit after 10seconds.
2. Using this method any combination of Transmitter input(s) can be paired to any Receiver output(s).
3. There is a maximum storage of 30 pairings.

Erase

To erase the ZPT memory and remove all stored transmitter pairings, connect the Learn Pin (5) to Ground for 10 seconds.

The Learn LED will illuminate while the pin is grounded and after it is disconnected will flash 3 times to Confirm memory erase has been completed.

Outputs

Outputs are LVTTTL / LVCMOS at Vcc and are Active high.

Momentary or Latching Function

Momentary: The ZPT Receiver outputs will follow the status of the ZPT Transmitter input status (when the ZPT Transmitter input is high, the ZPT Receiver output will be high, and when the ZPT Transmitter input is Low, the ZPT Receiver output will be low).

Latching: The ZPT Receiver outputs will change State each time the ZPT Transmitter input is asserted (ZPT Transmitter goes high to low).

when the ZPT Transmitter input goes from high to low, the ZPT Receiver output is activated on, when the ZPT Transmitter input goes from high to low again, the ZPT Receiver output is relaxed to OFF.

ZPT Receiver example application circuit

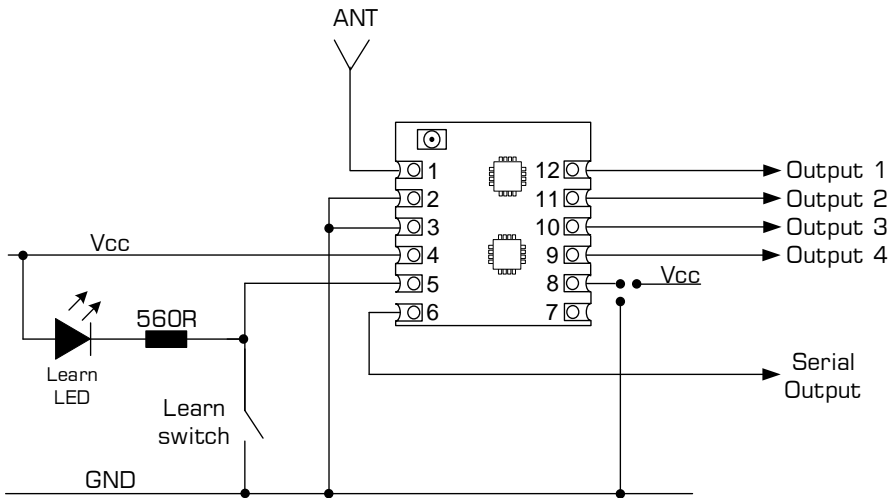

Description:

This example shows a ZPT module receiver with all 4 outputs connected.

Note: The external learn switch and learn LED are both shown connected in this example.

ZPT Receiver with Serial data output via MAX232

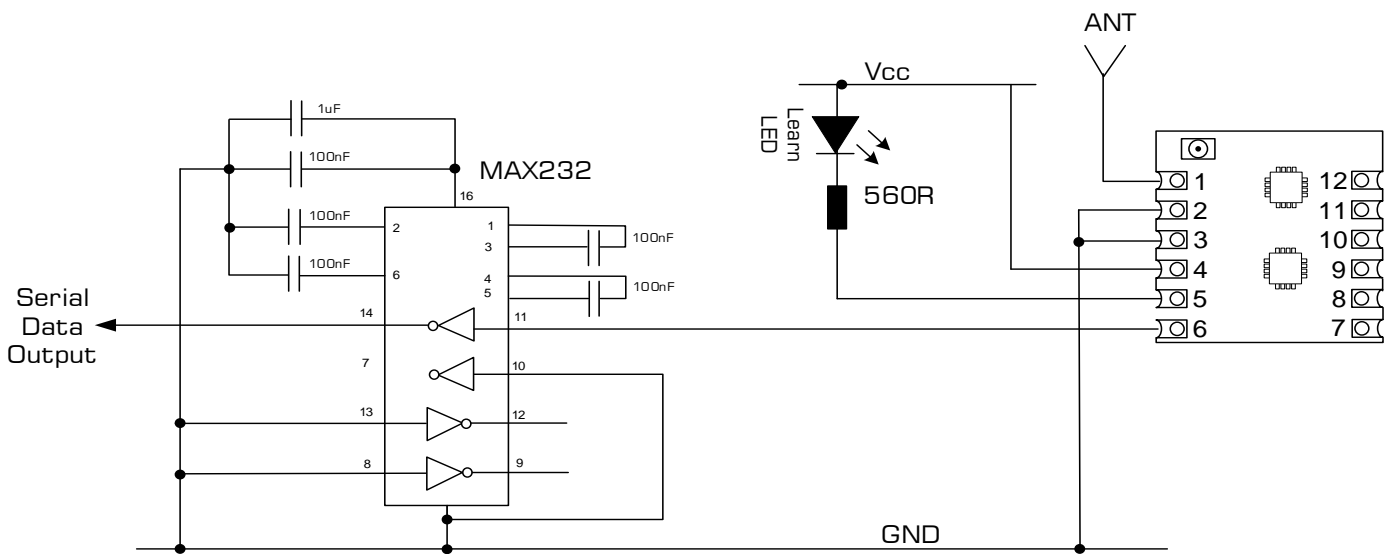

ZPT Receiver LED Output Status

Mode	LED	Description
Normal operation	OFF	No RF data is being transmitted/received
	Flickering	Module is receiving data
Learn and erase	ON	While input is connected to GND (i.e. during button press).
	Flashes	Flashes to show output selection and pairing success
	Flashes twice	ZPT pairing successful
	Flashes three times	ERASE successful

ZPT Receiver Serial Data Output

The ZPT outputs the serial number, button and battery status of the transmitter. This data may be fed directly to a microcontroller or RS232 type driver circuit which may then be fed directly to a PC serial port.

Serial data is output on every packet receipt - this equates to every 1/4 second whilst a button is held down/input active. This data output is valid regardless of whether the Transmitter/Encoder has been learnt or not. The serial data packet contains a learn bit to show if an encoder input is learnt.

Serial data configuration

Baud Rate: 19,200
Data bits: 8
Parity: none
Stop bits: 1
Handshaking: none

Serial data format:

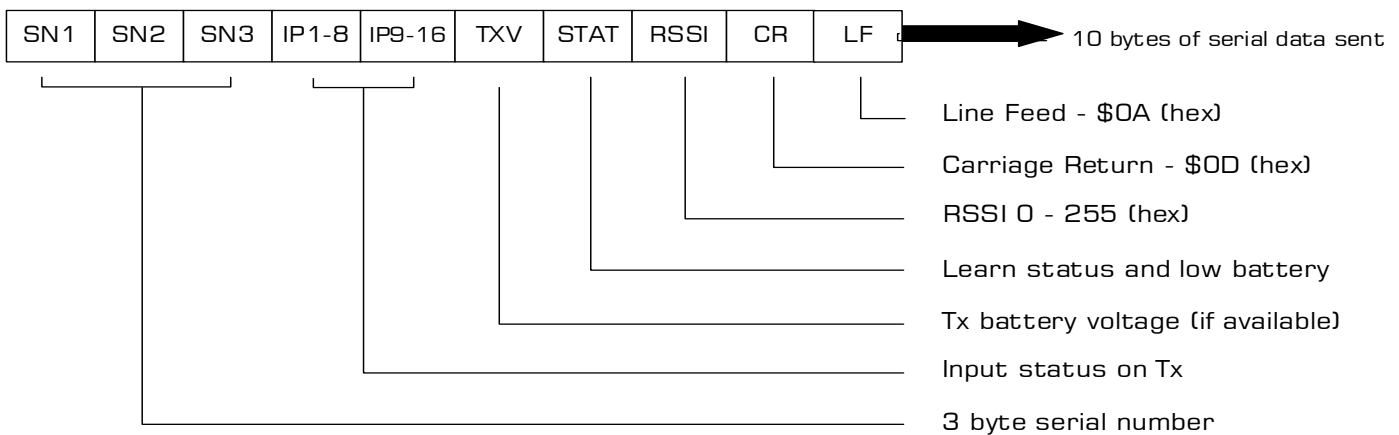

Serial number [SN1 SN2 SN3]:

Made up of three 8-bit bytes where the most significant byte is transmitted first.
 Example: 12ABAA (hexadecimal) or 0001 0010 1010 1011 1010 1010 (binary).

Tx inputs [IP1-8 IP9-16]:

made up of two 8-bit bytes. The low order byte is sent first representing inputs 8 down to 1 where the MSB is input 8 and the LSB is input 1. The high order byte is sent next representing inputs 16 down to 9 where the MSB is input 16 and the LSB is input 9.

A bit at state 1 represents an encoder input as active.

Using this method inputs can be multiplexed giving maximum versatility.

Example: 00000000 00010000 Shows input 13 active.

10000000 00000000 Shows input 8 active

10000001 10000000 Shows inputs 16, 8 and 1 active

Learn status and low battery:

One 8 bit byte:

Bit0 shows low battery on Tx - where 1 = Low battery

Bit1 shows learn status of Tx - where 1 = Learnt

RSSI

Received Signal Strength Indication.

Bespoke versions

Customised versions of the all transmitters, receivers and chipsets are available to provide a bespoke remote chipset for OEM.

ZPT Receiver Self Test Mode

ZPT Receiver modules incorporate a self test which is initiated by applying power with the learn button held down.

The module then performs the following functions:

1. All outputs operate in turn ON/OFF twice
2. All outputs flash ON/OFF 5 times - 1&3 and then 2&4
3. Transmits a full power RF signal for 5 seconds while flashing the learn LED
4. Enters RSSI (Received Signal Strength Indication) mode where outputs 1-4 are activated as a bar graph type output according to the strength of a valid RF signal received (from any carrier operating at the appropriate frequency (869.50MHz). 4 Outputs on being maximum strength.
5. To exit RSSI mode cycle power to the module.
6. A power cycle reset is required to exit

Module Identification

TX/RX Identification
 1 x Pink Dot = RX
 2 x Pink Dots = TX

Test Confirmation (Green)

Frequency of Operation
 Red = 433MHz
 Blue = 868MHz
 Brown = 915MHz

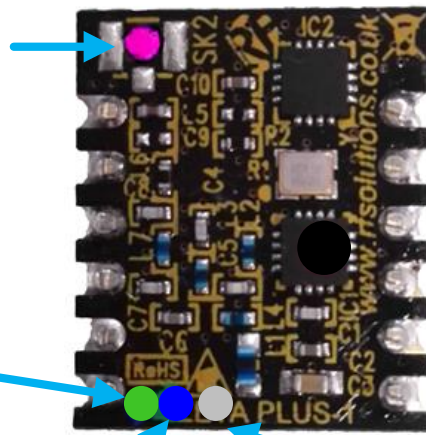

Revision numbers

- Rev 1 Brown
- Rev 2 Red
- Rev 3 Orange
- Rev 4 Yell
- Rev 5 Green
- Rev 6 Blue
- Rev 7 Violet
- Rev 8 Grey
- Rev 9 White

ZPT Revision Change History			
Part	Date	New Revision	Change / Fix
ZPT-8RS ZPT-8RS	17/3/20	2 2	Receiver Current consumption reduced
All versions	21/8/20	3	Revision 2 Modules experiencing random corrupt data packets which has now been rectified

Mechanical dimensions

Surface Mount Package

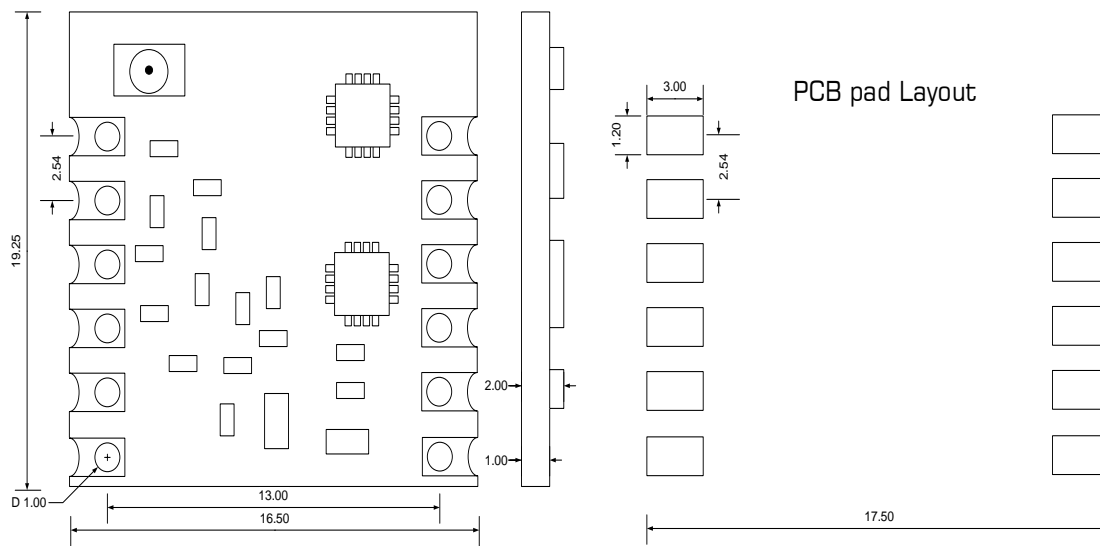

D Package

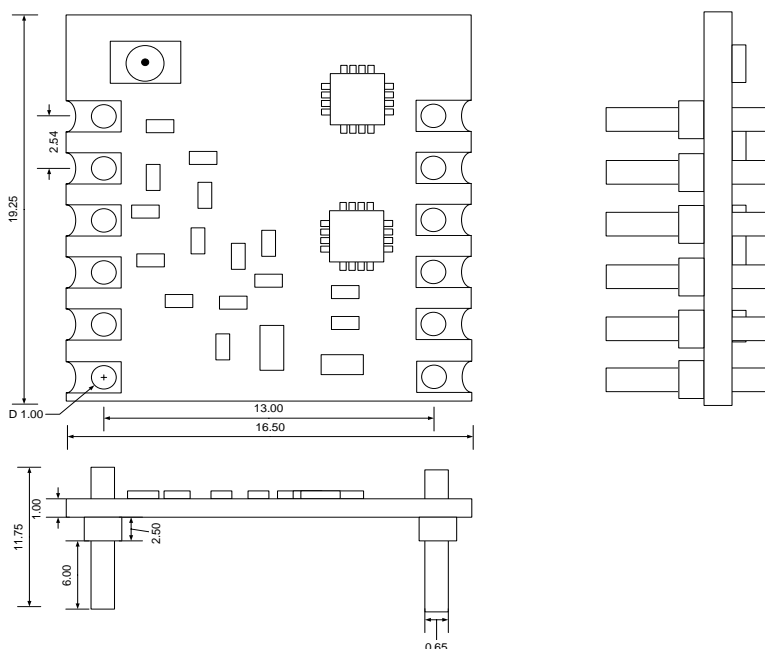

ZPK module re-flow guide

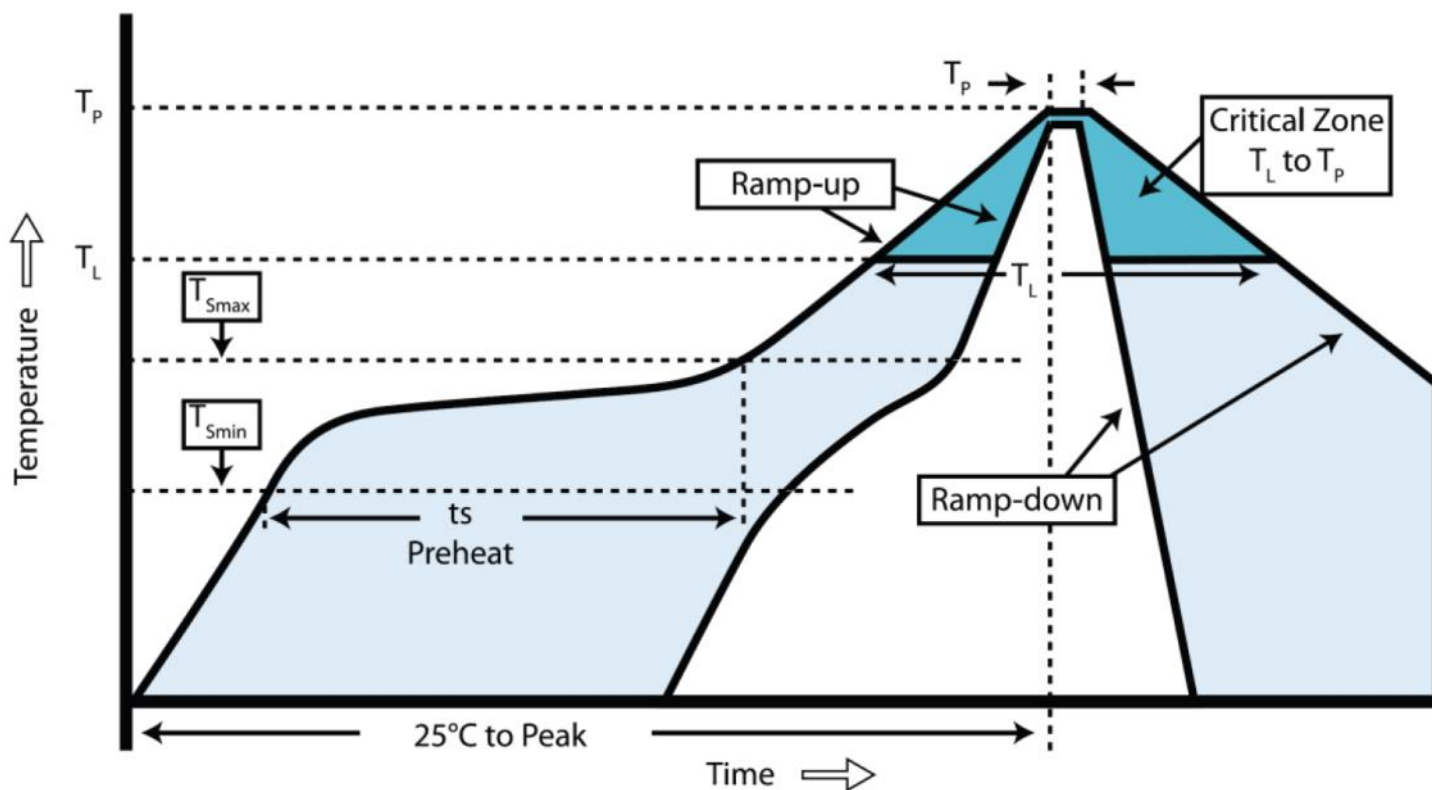

Profile feature	Value (lead free)
Ramp up rate	3°C /s
Pre-heat temperature	
- Temperature Min (T _{Smin})	150°C
- Temperature Max (T _{Smax})	200°C
- Pre-heat time	60-100s
Peak temperature (T _P)	240°C
Time at T _P	10-20sec
Ramp down rate	6°C/s
Time from 25°C to peak	8 mins max.

Electrical Characteristics

Parameter	Symbol	Test Condition	Min	Typ.	Max	Unit
Ambient Temperature	T_A		-20		85	°C
Supply Voltage	V_{DD}		1.8		3.6	V
I/O Drive Voltage	V_{GPIO}		1.8		3.6	V
Operating Frequency				433.92 869.50		MHz
TX Power				+13	+15	dBm
RX Sensitivity				-121		dBm

DC characteristics

Parameter	Symbol	Test Condition	Min	Typ.	Max	Unit
Supply voltage range	V_{CC}		1.8	3.3	3.6	V
TX Quiescent current	I_{TX}	RF Transmit mode in auto sleep	—		<1	uA
TX input draw when active		Current Draw per active input when not transmitting			10	uA
TX transmit current		Module is in RF Data transmit mode	—	24	—	mA
RX Power saving mode	I_{Sleep}	Module asleep shutdown pin active. Note all outputs are disabled	—		<1	uA
RX mode current	I_{RX}	Module is in RF Data receive mode	—	16	—	mA
Output Drive Capability		Output Low or High			5	mA

AC Characteristics

Parameter	Symbol	Test Condition	Min	Typ.	Max	Unit
Time from Tx Input asserted to Rx Output Active		Minimum Debounce on input*	22	25		mS
channel bandwidth	BW			60		kHz
Image rejection	Im_{REJ}	Rejection at the image frequency IF = 468kHz	—	-35	—	dB
Spurious emissions	P_{OB_RX1}	Measured at RX pins	—	-54	—	dBm

*The TX module will wait for an input to be stable DC (no noise) for min 2mS before considering the pin is asserted and then proceeding to transmit the RF Signal

Range Considerations

The antenna choice and position directly affects the system range, keep it clear of any large metal parts. The best position is protruding vertically from the top of the product. This is often not desirable for practical reasons and thus a compromise may be needed. Note that the space around the antenna is as important as the antenna itself. All radio systems are dependent on a radio signal being received through airspace.

The range quoted is the optimal in direct line of sight without obstacles and in good atmospheric conditions.

Range is affected by many things, for example local environmental conditions, atmospheric conditions, Interference from other radio transmitters. For evaluating the local environment please see our RF Meter (DS006).

In very worse case applications the range quoted may be reduced dramatically below the optimal range stated.

Important European compliance information

This RF Solutions radio module meets the essential requirements of the European Radio Equipment Directive 2014/53/EU and has been tested to European Harmonised Standards and CE marked where space allows. A copy of the EU Declaration of Conformity can be located on the RF Solutions Website,

www.rfsolutions.co.uk/certification-i59.

When using the module in an end product, continued compliance can only be assured by incorporating the module in accordance with RF Solutions specific installation instructions and in accordance with the published information on the RF Solutions product data sheet.

Article 3.1a and 3.1b of the EU Radio Equipment Directive 2014/53/EU should be assessed in the final product.

Failure to follow this guidance may result in a non-compliant product being placed on the European Market, for which RF Solutions cannot accept any responsibility.

Further guidance may be obtained from RF Solutions Technical Support.

ZPT Telemetry Modules



Simplified Declaration of Conformity (RED)

BG - С настоящото RF Solutions Limited декларира, че този тип радиосъоръжение дефинирани в този документ е в съответствие с Директива 2014/53/ЕС. Цялостният текст на ЕС декларацията за съответствие може да се намери на следния интернет адрес: www.rfsolutions.co.uk

CS - Tímto RF Solutions Limited prohlašuje, že typ rádiového zařízení definované v tomto dokumentu je v souladu se směrnicí 2014/53/EU. Úplné znění EU prohlášení o shodě je k dispozici na této internetové adrese: www.rfsolutions.co.uk

DA - Hermed erklærer RF Solutions Limited, at radioudstyrstypen defineret i dette dokument er i overensstemmelse med direktiv 2014/53/EU. EU-overensstemmelseserklæringens fulde tekst kan findes på følgende internetadresse: www.rfsolutions.co.uk

DE - Hiermit erklärt RF Solutions Limited, dass der Funkanlagentyp in diesem Dokument definiert der Richtlinie 2014/53/EU entspricht. Der vollständige Text der EU-Konformitätserklärung ist unter der folgenden Internetadresse verfügbar: www.rfsolutions.co.uk

EL - Με την παρούσα ο/η RF Solutions Limited, δηλώνει ότι ο ραδιοεξοπλισμός ορίζεται σε αυτό το έγγραφο πληροί την οδηγία 2014/53/ΕΕ. Το πλήρες κείμενο της δήλωσης συμμόρφωσης ΕΕ διατίθεται στην ακόλουθη ιστοσελίδα στο διαδίκτυο: www.rfsolutions.co.uk

EN - Hereby, RF Solutions Limited declares that the radio equipment type defined within this document is in compliance with Directive 2014/53/EU. The full text of the EU declaration of conformity is available at the following internet address: www.rfsolutions.co.uk

ES - Por la presente, RF Solutions Limited declara que el tipo de equipo radioeléctrico definido dentro de este documento es conforme con la Directiva 2014/53/UE. El texto completo de la declaración UE de conformidad está disponible en la dirección Internet siguiente: www.rfsolutions.co.uk

ET - Käesolevaga deklareerib RF Solutions Limited, et käesolev raadioseadme tüüp määratletud selles dokumendis vastab direktiivi 2014/53/EL nõuetele. ELi vastavusdeklaratsiooni täielik tekst on kättesaadav järgmisel internetiaadressil: www.rfsolutions.co.uk

FI - RF Solutions Limited vakuuttaa, että radiolaitetyypin määrättyä selles dokumentissa on direktiivin 2014/53/EU mukainen. EU-vaatimustenmukaisuusvakuutuksen täysimittainen teksti on saatavilla seuraavassa internetosoitteessa: www.rfsolutions.co.uk

FR - Le soussigné, RF Solutions Limited, déclare que l'équipement radioélectrique du type défini dans ce document est conforme à la directive 2014/53/UE. Le texte complet de la déclaration UE de conformité est disponible à l'adresse internet suivante: www.rfsolutions.co.uk

HR - RF Solutions Limited ovime izjavljuju da je radijska oprema tipa definirani u ovom dokumentu u skladu s Direktivom 2014/53/EU. Cjeloviti tekst EU izjave o sukladnosti dostupan je na sljedećoj internetskoj adresi: www.rfsolutions.co.uk

HU - RF Solutions Limited igazolja, hogy a dokumentumban meghatározottak szerint típusú rádióberendezés megfelel a 2014/53/EU irányelvnek. Az EU-megfelelőségi nyilatkozat teljes szövege elérhető a következő internetes címen: www.rfsolutions.co.uk

IT - Il fabbricante, RF Solutions Limited, dichiara che il tipo di apparecchiatura radio definito all'interno di questo documento è conforme alla direttiva 2014/53/UE. Il testo completo della dichiarazione di conformità UE è disponibile al seguente indirizzo Internet: www.rfsolutions.co.uk

LT - Aš, RF Solutions Limited, patvirtinu, kad radijo įrenginių tipas apibrėžta šiame dokumente atitinka Direktyvą 2014/53/ES. Visas ES atitikties deklaracijos tekstas prieinamas šiuo interneto adresu: www.rfsolutions.co.uk

LV - Ar šo RF Solutions Limited deklarē, ka radioiekārta kas definēts šajā dokumentā atbilst Direktīvai 2014/53/ES. Pilns ES atbilstības deklarācijas teksts ir pieejams šādā interneta vietnē: www.rfsolutions.co.uk

MT - B'dan, RF Solutions Limited, niddikjara li dan it-tip ta' tagħmir tar-radju definit f'dan id-dokument huwa konformi mad-Direttiva 2014/53/UE. It-test kollu tad-dikjarazzjoni ta' konformità tal-UE huwa disponibbli f'dan l-indirizz tal-Internet li ġej: www.rfsolutions.co.uk

NL - Hierbij verklaar ik, RF Solutions Limited, dat het type radioapparatuur gedefinieerd in dit document conform is met Richtlijn 2014/53/EU. De volledige tekst van de EU-conformiteitsverklaring kan worden geraadpleegd op het volgende internetadres: www.rfsolutions.co.uk

PL - RF Solutions Limited niniejszym oświadcza, że typ urządzenia radiowego zdefiniowane w tym dokumencie jest zgodny z dyrektywą 2014/53/UE. Pełny tekst deklaracji zgodności UE jest dostępny pod następującym adresem internetowym: www.rfsolutions.co.uk

PT - O(a) abaixo assinado(a) RF Solutions Limited declara que o presente tipo de equipamento de rádio definido neste documento está em conformidade com a Diretiva 2014/53/UE. O texto integral da declaração de conformidade está disponível no seguinte endereço de Internet: www.rfsolutions.co.uk

RO - Prin prezenta, RF Solutions Limited declară că tipul de echipamente radio definit în acest document este în conformitate cu Directiva 2014/53/UE. Textul integral al declarației UE de conformitate este disponibil la următoarea adresă internet: www.rfsolutions.co.uk

SK - RF Solutions Limited týmto vyhlasuje, že rádiové zariadenie typu definované v tomto dokumente je v súlade so smernicou 2014/53/EÚ. Úplné EÚ vyhlásenie o zhode je k dispozícii na tejto internetovej adrese: www.rfsolutions.co.uk

SL - RF Solutions Limited potrjuje, da je tip radijske opreme opredeljeno v tem dokumentu skladen z Direktivo 2014/53/EU. Celotno besedilo izjave EU o skladnosti je na voljo na naslednjem spletnem naslovu: www.rfsolutions.co.uk

SV - Härmed försäkrar RF Solutions Limited att denna typ av radioutrustning definieras i detta dokument överensstämmer med direktiv 2014/53/EU. Den fullständiga texten till EU-försäkran om överensstämmelse finns på följande webbadress: www.rfsolutions.co.uk

RF Solutions Ltd. Recycling Notice

Meets the following EC Directives:

DO NOT

Discard with normal waste, please recycle.

ROHS Directive 2011/65/EU and amendment 2015/863/EU

Specifies certain limits for hazardous substances.

WEEE Directive 2012/19/EU

Waste electrical & electronic equipment. This product must be disposed of through a licensed WEEE collection point. RF Solutions Ltd., fulfills its WEEE obligations by membership of an approved compliance scheme, environment agency registration number **WEE/JB0101WV**.



Disclaimer:

Whilst the information in this document is believed to be correct at the time of issue, RF Solutions Ltd does not accept any liability whatsoever for its accuracy, adequacy or completeness. No express or implied warranty or representation is given relating to the information contained in this document. RF Solutions Ltd reserves the right to make changes and improvements to the product(s) described herein without notice. Buyers and other users should determine for themselves the suitability of any such information or products for their own particular requirements or specification(s). RF Solutions Ltd shall not be liable for any loss or damage caused as a result of user's own determination of how to deploy or use RF Solutions Ltd's products. Use of RF Solutions Ltd products or components in life support and/or safety applications is not authorised except with express written approval. No licences are created, implicitly or otherwise, under any of RF Solutions Ltd's intellectual property rights. Liability for loss or damage resulting or caused by reliance on the information contained herein or from the use of the product (including liability resulting from negligence or where RF Solutions Ltd was aware of the possibility of such loss or damage arising) is excluded. This will not operate to limit or restrict RF Solutions Ltd's liability for death or personal injury resulting from its negligence.

www.rfsolutions.co.uk

RF Solutions Ltd

William Alexander House, William Way, Burgess Hill, West Sussex, RH15 9AG

Sales: +44 (0)1444 227900

Tech Support: +44 (0)1444 227909

