

1.2A Synchronous Step-Up DC/DC Converter with Input Current Limit

FEATURES

- Programmable Average Input Current Limit
- 5% Input Current Accuracy
- 200mA to 1000mA Program Range
- V_{IN} : 1.8V to 5.5V, V_{OUT} : 2V to 5.25V
- Supports High Current GSM/GPRS Load Burst
- $V_{IN} > V_{OUT}$ Operation
- 1.6MHz Fixed Frequency Operation
- Internal Current Sense Resistor
- 1.2A Peak Current Limit
- Up to 93% Efficiency
- Output Disconnect in Shutdown
- Soft-Start
- Low Quiescent Current Burst Mode[®] Operation (15 μ A)
- Available in 2mm \times 3mm \times 0.75mm DFN Package

APPLICATIONS

- GSM/GPRS PCMCIA/CompactFlash PC Card Modems
- Wireless Emergency Locators
- Portable Radios
- Supercap Chargers

DESCRIPTION

The LTC[®]3125 is a high efficiency, synchronous step-up DC/DC converter with an accurate programmable average input current limit. The $\pm 5\%$ accurate average input current is resistor programmable and suitable for a wide variety of applications. In mobile computing, GSM and GPRS cards demand high current pulses well beyond the capability of the PC Card and CompactFlash slots. The LTC3125 in concert with a reservoir capacitor, keeps the slot power safely within its capabilities providing a high performance and simple solution.

Synchronous rectification produces high efficiency while the 1.6MHz switching frequency minimizes the solution footprint. The current mode PWM design is internally compensated. Output disconnect allows the load to discharge in shutdown, while also providing inrush current limiting.

Other features include a $< 1\mu$ A shutdown current, short-circuit and thermal overload protection. The LTC3125 is offered in a low profile 0.75mm \times 2mm \times 3mm package.

LT, LT, LTC, LTM and Burst Mode are registered trademarks of Linear Technology Corporation. All other trademarks are the property of their respective owners.

TYPICAL APPLICATION

PCMCIA/CompactFlash (3.3V/500mA Max),
4V GSM Pulsed Load

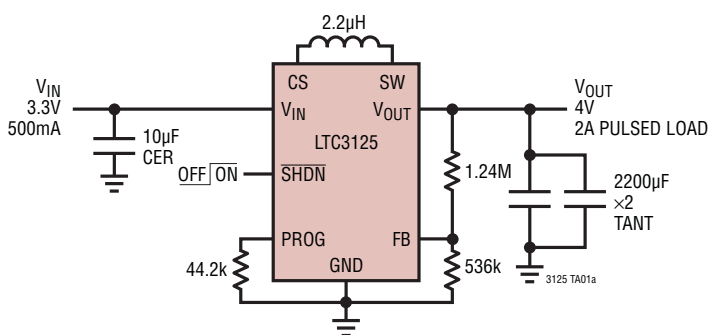

Efficiency vs Load Current

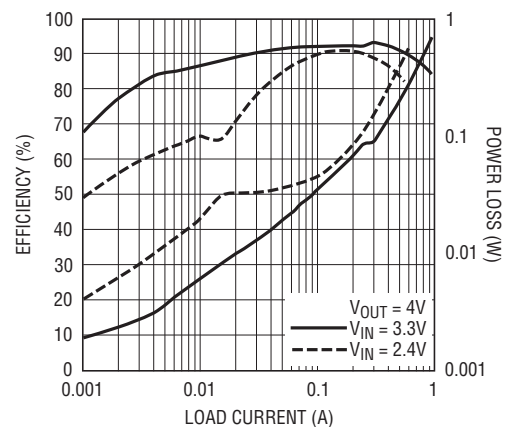

3125 TA01b

LTC3125

ABSOLUTE MAXIMUM RATINGS

(Note 1)

V_{IN} , V_{OUT} Voltage	-0.3V to 6V
SW Voltage	-0.3V to 6V
SW Voltage < 100ns	-0.3V to 7V
All Other Pins	-0.3V to 6V
Operating Temperature Range (Notes 2, 5)	-40°C to 85°C
Junction Temperature	125°C
Storage Temperature Range	-65°C to 125°C

PIN CONFIGURATION

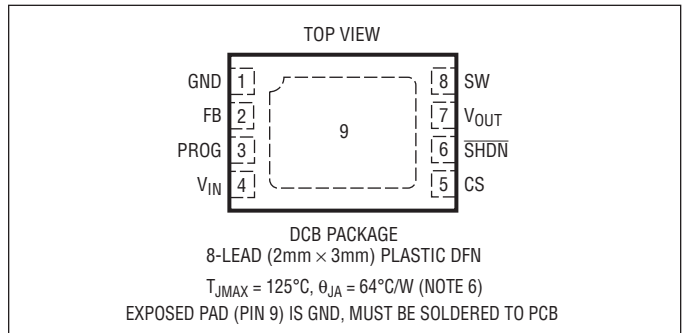

ORDER INFORMATION

LEAD FREE FINISH	TAPE AND REEL	PART MARKING	PACKAGE DESCRIPTION	TEMPERATURE RANGE
LTC3125EDCB#PBF	LTC3125EDCB#TRPBF	LDGY	8-Lead (2mm × 3mm) Plastic DFN	-40°C to 85°C

Consult LTC Marketing for parts specified with wider operating temperature ranges.

Consult LTC Marketing for information on non-standard lead based finish parts.

For more information on lead free part marking, go to: <http://www.linear.com/leadfree/>

For more information on tape and reel specifications, go to: <http://www.linear.com/tapeandreeel/>

ELECTRICAL CHARACTERISTICS

The ● denotes the specifications which apply over the full operating temperature range, otherwise specifications are at $T_A = 25^\circ\text{C}$. $V_{IN} = 3.3\text{V}$, $V_{OUT} = 4.5\text{V}$ unless otherwise noted.

PARAMETER	CONDITIONS	MIN	TYP	MAX	UNITS	
Input Voltage Range		1.8		5.5	V	
Minimum Start-Up Voltage		●	1.6	1.8	V	
Output Voltage Adjust Range		●	2	5.25	V	
Feedback Voltage		●	1.176	1.200	1.229	V
Feedback Input Current			1	50	nA	
Quiescent Current—Shutdown	$V_{SHDN} = 0\text{V}$, Not Including Switch Leakage, $V_{OUT} = 0\text{V}$		0.01	1	μA	
Quiescent Current—Active	Measured on V_{OUT} , Nonswitching		300	500	μA	
Quiescent Current—Burst	Measured on V_{OUT} , $\text{FB} = 1.230\text{V}$		15	25	μA	
N-Channel MOSFET Switch Leakage	$V_{SW} = 5\text{V}$, $V_{IN} = 5\text{V}$		0.1	10	μA	
P-Channel MOSFET Switch Leakage	$V_{SW} = 5\text{V}$, $V_{OUT} = 0\text{V}$, $V_{IN} = 5\text{V}$		0.1	20	μA	
N-Channel MOSFET Switch On-Resistance	$V_{OUT} = 3.3\text{V}$		0.125		Ω	
P-Channel MOSFET Switch On-Resistance	$V_{OUT} = 3.3\text{V}$		0.200		Ω	
N-Channel MOSFET Current Limit		●	1.2	1.8	A	
Current Limit Delay to Output	(Note 3)		60		ns	
Average Input Current Limit	$R_{PROG} = 44.2\text{k}$	●	475	500	525	mA
	$R_{PROG} = 44.2\text{k}$, -40°C to 85°C		465	500	535	mA

3125f

ELECTRICAL CHARACTERISTICS The ● denotes the specifications which apply over the full operating temperature range, otherwise specifications are at $T_A = 25^\circ\text{C}$. $V_{IN} = 3.3\text{V}$, $V_{OUT} = 4.5\text{V}$ unless otherwise noted.

PARAMETER	CONDITIONS	MIN	TYP	MAX	UNITS
PROG Current Gain	(Note 3)		22.1		k Ω -A/A
Maximum Duty Cycle	$V_{FB} = 1.15\text{V}$	● 85	92		%
Minimum Duty Cycle	$V_{FB} = 1.3\text{V}$	●		0	%
Frequency		● 1.3	1.6	1.9	MHz
SHDN Input High		1			V
SHDN Input Low				0.35	V
SHDN Input Current	$V_{SHDN} = 1.2\text{V}$		0.3	1	μA

Note 1: Stresses beyond those listed under Absolute Maximum Ratings may cause permanent damage to the device. Exposure to any Absolute Maximum Rating condition for extended periods may affect device reliability and lifetime.

Note 2: The LTC3125 is guaranteed to meet performance specifications from 0°C to 85°C . Specifications over -40°C to 85°C operating temperature range are assured by design, characterization and correlation with statistical process controls.

Note 3: Specification is guaranteed by design and not 100% tested in production.

Note 4: Current measurements are made when the output is not switching.

Note 5: This IC includes overtemperature protection that is intended to protect the device during momentary overload conditions. Junction temperature will exceed 125°C when overtemperature protection is active. Continuous operation above the specified maximum operating junction temperature may result in device degradation or failure.

Note 6: Failure to solder the exposed backside of the package to the PC board ground plane will result in a thermal resistance much higher than 60°C/W .

TYPICAL PERFORMANCE CHARACTERISTICS ($T_A = 25^\circ\text{C}$ unless otherwise noted)

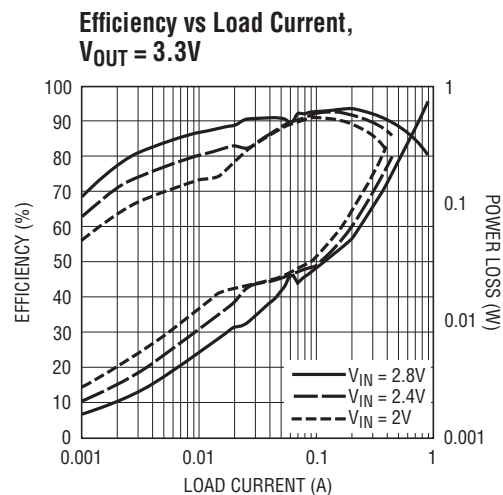
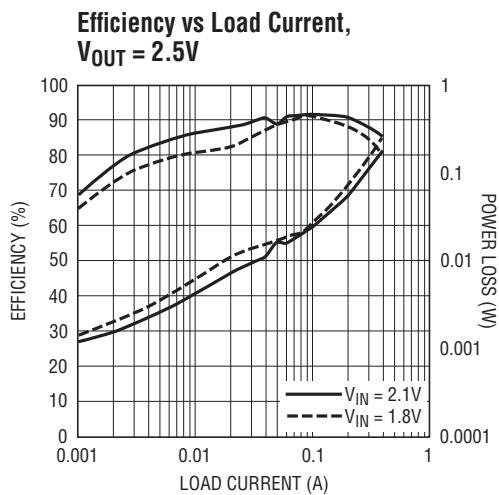

TYPICAL PERFORMANCE CHARACTERISTICS ($T_A = 25^\circ\text{C}$ unless otherwise noted)

Efficiency vs Load Current, $V_{OUT} = 5V$

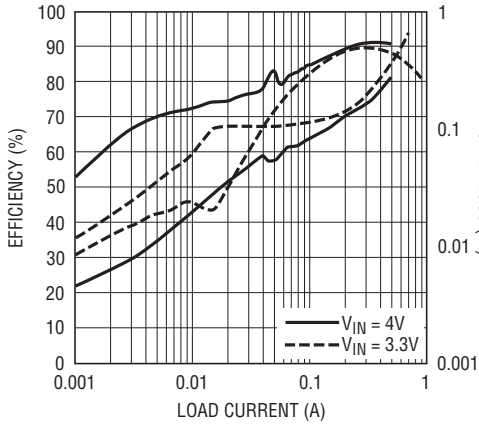

3125 G03

No-Load Input Current vs V_{IN}

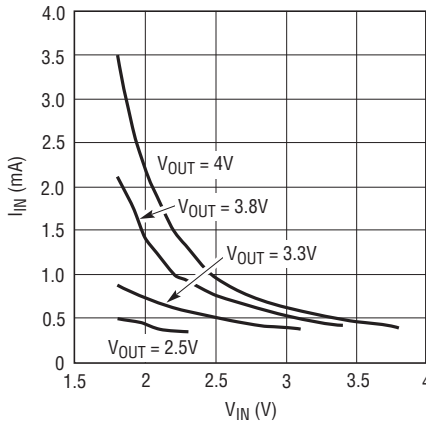

3125 G04

Average Input Current Limit vs V_{IN}

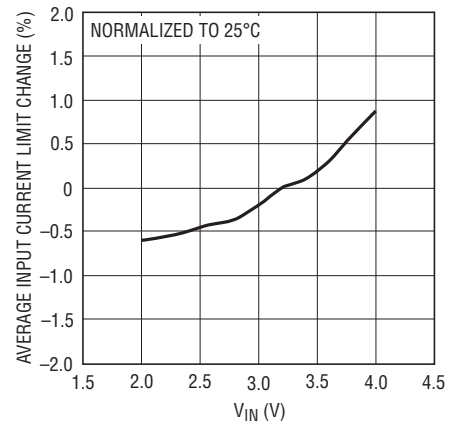

3125 G05

Average Input Current Limit vs Temperature

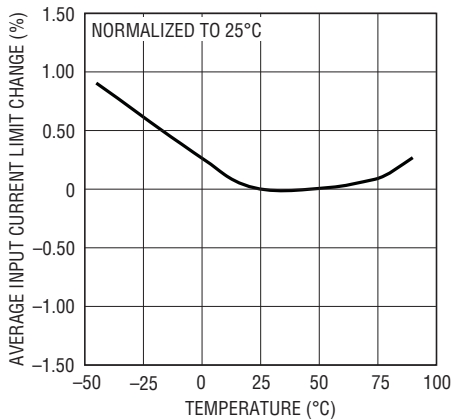

3125 G06

Average Input Current vs R_{PROG}

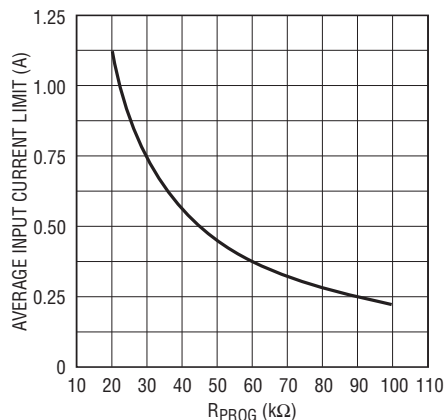

3125 G07

Peak Current Limit vs V_{IN}

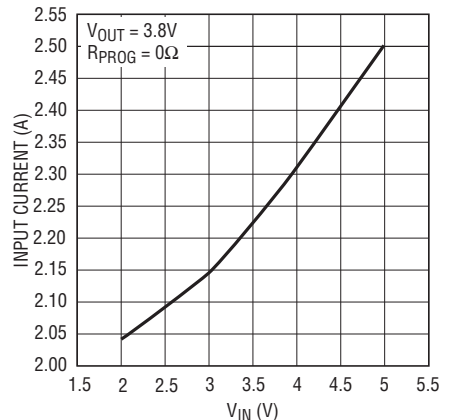

3125 G08

Burst Mode Threshold Current vs V_{IN}

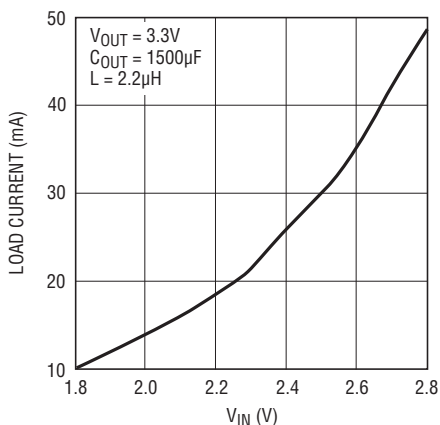

3125 G09

Burst Mode Threshold Current vs V_{IN}

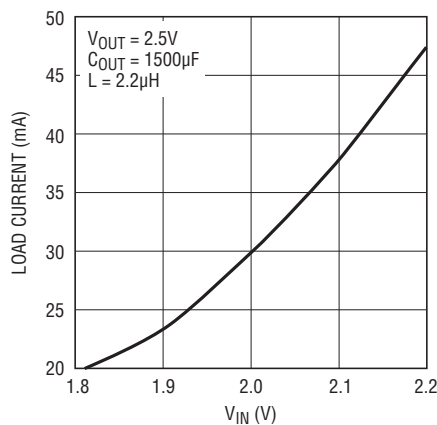

3125 G10

Oscillator Frequency vs V_{OUT}

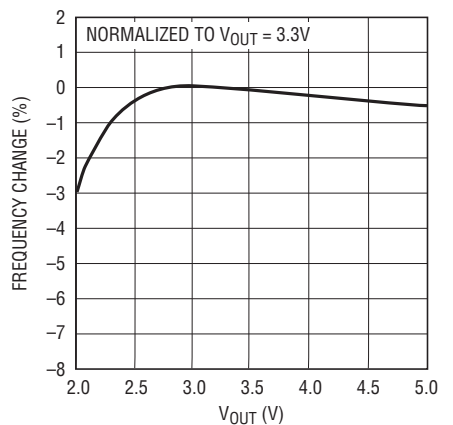

3125 G11

TYPICAL PERFORMANCE CHARACTERISTICS ($T_A = 25^\circ\text{C}$ unless otherwise noted)

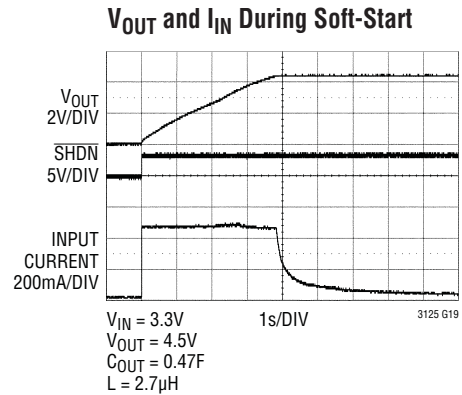
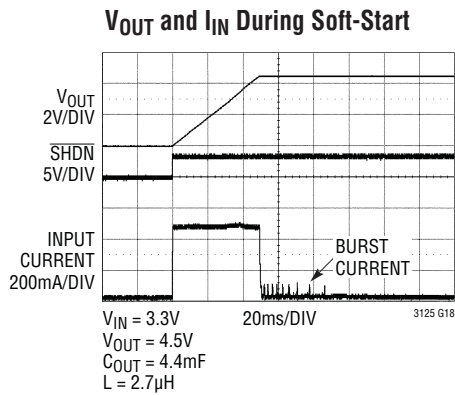
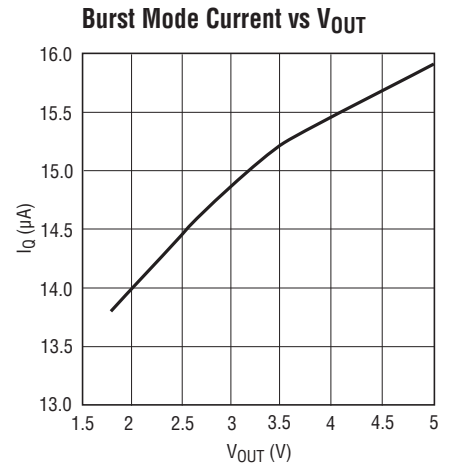
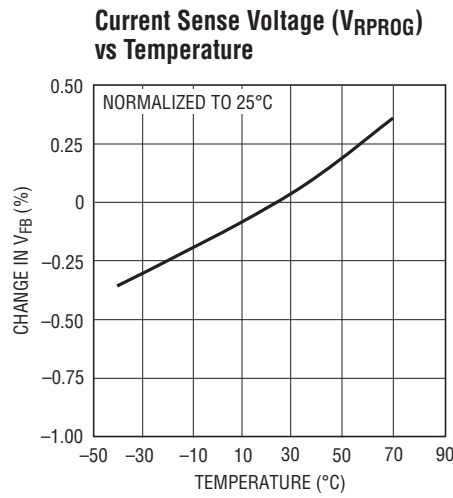
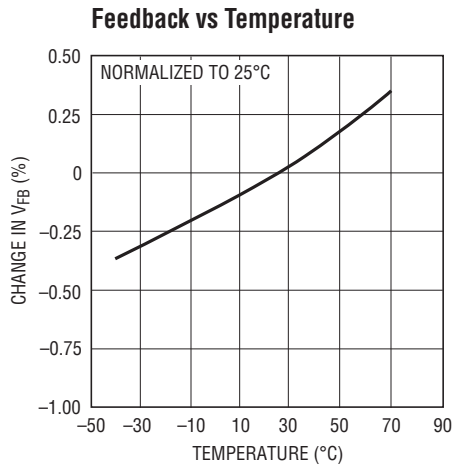
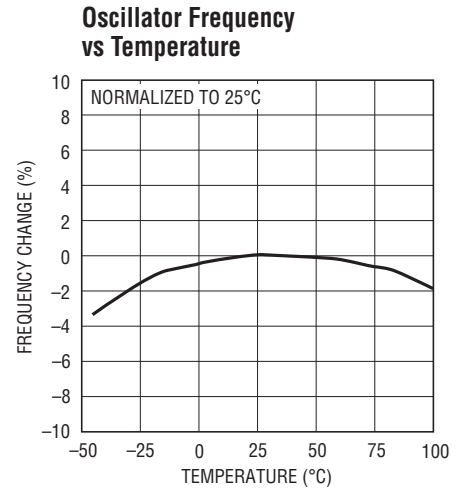
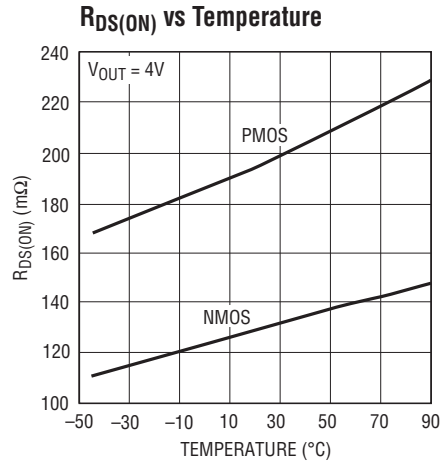
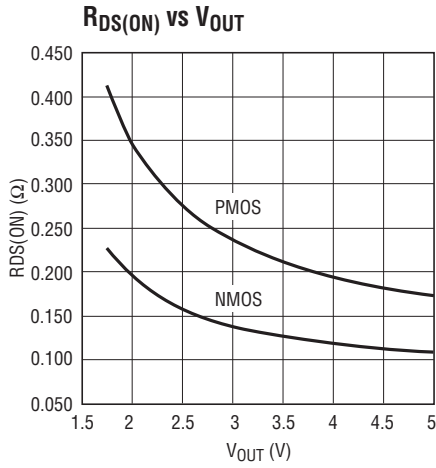

TYPICAL PERFORMANCE CHARACTERISTICS ($T_A = 25^\circ\text{C}$ unless otherwise noted)

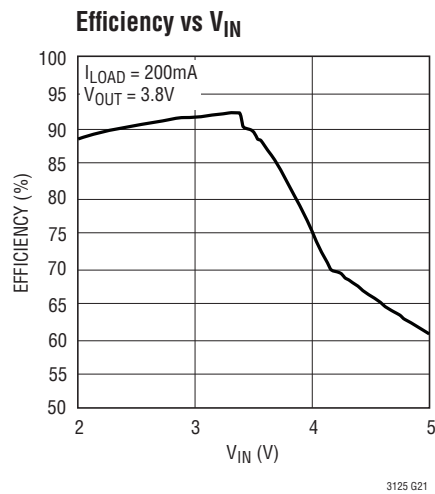
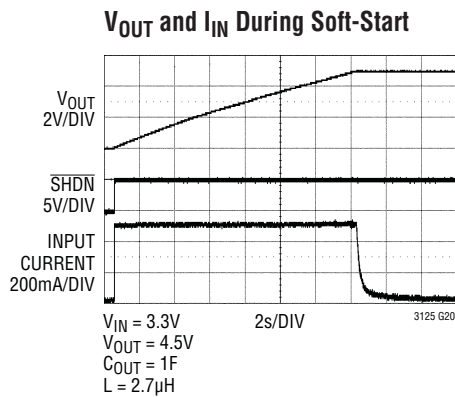

3125 G21

PIN FUNCTIONS

GND (Pin 1): Signal Ground.

FB (Pin 2): Feedback Input to the Error Amplifier. Connect the resistor divider tap to this pin. The top of the divider connects to V_{OUT} and the bottom of the divider connects to GND. The output voltage can be adjusted from 1.8V to 5.25V.

PROG (Pin 3): Programming Input for Average Input Current. This pin should be connected to ground through an external resistor (R_{PROG}) to set input average current limit threshold. PROG pin gain = $22.1\text{k}\Omega\text{-A/A}$. The average input current limit threshold is set by R_{PROG} according to the following:

$$R_{PROG} = \frac{22.1\text{k}\Omega\text{-A}}{\text{Desired } I_{AVG} \text{ (A)}}$$

V_{IN} (Pin 4): Input Voltage. The device is powered from V_{IN} until V_{OUT} exceeds V_{IN} . Once V_{OUT} is greater than ($V_{IN} + 0.25\text{V}$), the device is powered from V_{OUT} . Place a ceramic bypass capacitor from V_{IN} to GND. A minimum value of $1\mu\text{F}$ is recommended. Also connects to CS through $60\text{m}\Omega$ internal sense resistor.

CS (Pin 5): Current Sense Resistor Connection Point. Connect the inductor directly to CS. An internal $60\text{m}\Omega$ sense resistor is connected between CS and V_{IN} .

SHDN (Pin 6): Logic Controlled Shutdown Input. Bringing this pin above 1V enables the part, forcing this pin below 0.35V disables the part.

V_{OUT} (Pin 7): Output Voltage Sense and the Output of the Synchronous Rectifier. Connect the output filter capacitor from V_{OUT} to GND, close to the IC. A minimum value of $10\mu\text{F}$ ceramic is recommended. Due to the output disconnect feature, V_{OUT} is disconnected from V_{IN} when $\overline{\text{SHDN}}$ is low.

SW (Pin 8): Switch Pin. Connect an inductor from this pin to CS. An internal anti-ringing resistor is connected across SW and CS after the inductor current has dropped near zero.

Exposed Pad (Pin 9): Power Ground. This pin must be soldered to the PCB ground plane.

BLOCK DIAGRAM

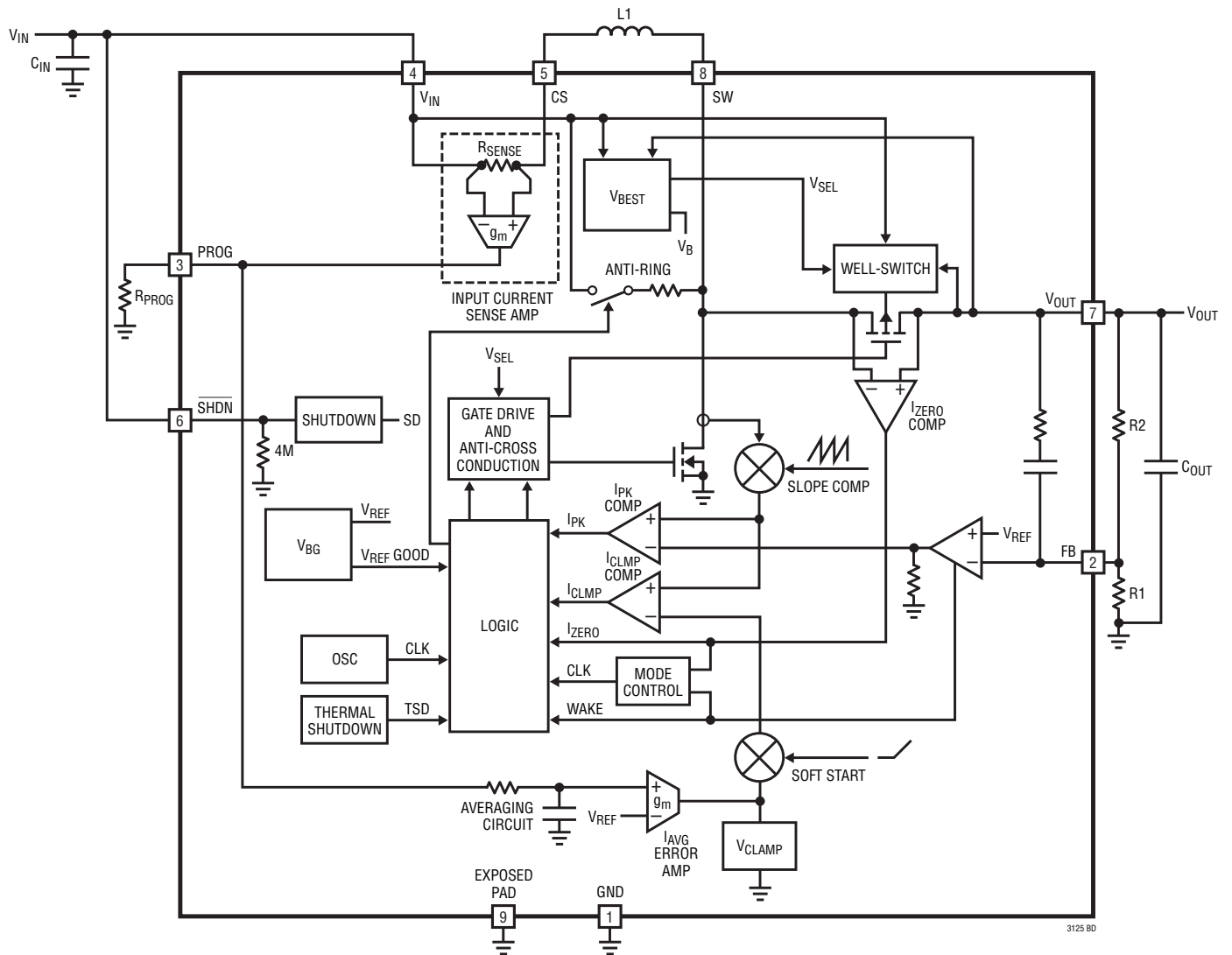

3125 BD

OPERATION

The LTC3125 provides high efficiency, low noise power for applications in portable instrumentation and those with pulsed-load, power-limited requirements such as GSM modems.

The LTC3125 directly and accurately controls the average input current. The high efficiency of the LTC3125 provides the maximum possible output current to the load without impacting the host. Together with an external bulk capacitor the LTC3125 with average input current limit allows a GSM/GPRS modem to be interfaced directly to a PCMCIA or CompactFlash power bus without overloading it.

The current mode architecture with adaptive slope compensation provides excellent transient load response, requiring minimal output filtering. Internal soft-start and loop compensation simplifies the design process while minimizing the number of external components.

With its low $R_{DS(ON)}$ and low gate charge internal N-channel MOSFET switch and P-channel MOSFET synchronous rectifier, the LTC3125 achieves high efficiency over a wide range of load currents. Automatic Burst Mode operation maintains high efficiency at very light loads, reducing the quiescent current to just 15 μ A.

ERROR AMPLIFIER

The noninverting input of the transconductance error amplifier is internally connected to the 1.2V reference and the inverting input is connected to FB. Clamps limit the minimum and maximum error amp output voltage for improved large-signal transient response. Power converter control loop compensation is provided internally. An external resistive voltage divider from V_{OUT} to ground programs the output voltage via FB from 2V to 5.25V.

$$V_{OUT} = 1.2V \left(1 + \frac{R2}{R1} \right)$$

INTERNAL CURRENT LIMIT

Lossless current sensing converts the peak current signal of the N-channel MOSFET switch into a voltage that is summed

with the internal slope compensation. The summed signal is compared to the error amplifier output to provide a peak current control command for the PWM.

A second current limit comparator shuts off the N-channel MOSFET switch once the peak current signal clamp threshold is reached. The current limit comparator delay to output is typically 60ns. Peak switch current is limited to approximately 1.8A, independent of input or output voltage, unless V_{OUT} falls below 0.8V, in which case the current limit is cut in half.

AVERAGE INPUT CURRENT LIMIT

Input current is sensed with an internal 60m Ω resistor and converted to a voltage. A transconductance amplifier creates a proportional current which is then forced into an external resistor. The voltage across the resistor is averaged and compared to a temperature stable internal reference. The result of this comparison is used to actively control the current limit comparator's clamp threshold. The high gain of this loop forces the average input current to the limit set by the external resistor, R_{PROG} .

$$R_{PROG} = \frac{22.1k\Omega \cdot A}{\text{Desired } I_{AVG} \text{ (A)}}$$

Note that the LTC3125's input current averaging circuit may introduce a slightly higher inductor ripple than expected. This is normal and has no effect on the average input current seen by the power source.

ZERO CURRENT COMPARATOR

The zero current comparator monitors the inductor current to the output and shuts off the synchronous rectifier when this current reduces to approximately 30mA. This prevents the inductor current from reversing in polarity, improving efficiency at light loads.

OSCILLATOR

An internal oscillator sets the switching frequency to 1.6MHz.

OPERATION

SHUTDOWN

Shutdown of the boost converter is accomplished by pulling $\overline{\text{SHDN}}$ below 0.35V and enabled by pulling $\overline{\text{SHDN}}$ above 1V. Note that $\overline{\text{SHDN}}$ can be driven above V_{IN} or V_{OUT} , as long as it is limited to less than the absolute maximum rating.

OUTPUT DISCONNECT

The LTC3125 is designed to allow true output disconnect by eliminating body diode conduction of the internal P-channel MOSFET rectifier. This allows for V_{OUT} to go to zero volts during shutdown, drawing no current from the input source. It also limits inrush current at turn-on, minimizing surge currents seen by the input supply. Note that to obtain the advantages of output disconnect, there cannot be an external Schottky diode connected between the SW pin and V_{OUT} . The output disconnect feature also allows V_{OUT} to be pulled high, without any reverse current into the power source connected to V_{IN} .

THERMAL SHUTDOWN

If the die temperature exceeds 160°C typical, the LTC3125 will go into thermal shutdown. All switches will be off and the soft-start capacitor will be discharged. The device will be enabled again when the die temperature drops by approximately 15°C.

SYNCHRONOUS RECTIFIER

To control inrush current and to prevent the inductor current from running away when V_{OUT} is close to V_{IN} , the P-channel MOSFET synchronous rectifier is only enabled when $V_{\text{OUT}} > (V_{\text{IN}} + 0.38\text{V})$.

ANTI-RINGING CONTROL

The anti-ringing control connects a resistor across the inductor to prevent high frequency ringing on the SW pin during discontinuous current mode operation. Although the ringing of the resonant circuit formed by L and C_{SW} (capacitance on SW pin) is low energy, it can cause EMI radiation.

SOFT-START

The LTC3125 contains internal circuitry to provide soft-start operation. The soft-start circuitry slowly ramps the peak inductor current from zero to its peak value of 1.8A (typical) in approximately 0.5ms, allowing start-up into heavy loads. The soft-start circuitry is reset in the event of a shutdown command or a thermal shutdown.

Burst Mode OPERATION

The LTC3125 will automatically enter Burst Mode operation at light load and return to fixed frequency PWM mode when the load increases. Refer to the Typical Performance Characteristics to see the output load Burst Mode threshold current vs V_{IN} . The load current at which Burst Mode operation is entered can be changed by adjusting the inductor value. Raising the inductor value will lower the load current at which Burst Mode operation is entered.

In Burst Mode operation, the LTC3125 still switches at a fixed frequency of 1.6MHz, using the same error amplifier and loop compensation for peak current mode control. This control method eliminates any output transient when switching between modes. In Burst Mode operation, energy is delivered to the output until it reaches the nominal regulation value, then the LTC3125 transitions to sleep mode where the outputs are off and the LTC3125 consumes only 15 μA of quiescent current from V_{OUT} . When the output voltage droops slightly, switching resumes. This maximizes efficiency at very light loads by minimizing switching and quiescent losses.

As the load current increases, the LTC3125 will automatically leave Burst Mode operation. Once the LTC3125 has left Burst Mode operation and returned to normal operation, it will remain there until the output load is reduced below the burst threshold.

Burst Mode operation is inhibited during start-up and soft-start and until V_{OUT} is at least 0.38V greater than V_{IN} .

APPLICATIONS INFORMATION

GSM and GPRS modems have become a popular wireless data transfer solution for use in notebook PCs and other mobile systems. GSM transmission requires large bursts of current that exceed the maximum peak current specifications for CompactFlash and PCMCIA bus power.

The GSM standard specifies a 577 μ s, 2A (typical) transmission burst within a 4.6ms period (12.5% duty cycle). During the receive and standby periods the current consumption drops to 70mA (typical), yielding an average current requirement of 320mA.

Other standards (such as GPRS, Class 10) define a higher data rate. One popular requirement transmits two 2A bursts (3A worst case) within a 4.6ms frame period (70mA standby current) demanding an 800mA average input current. The LTC3125 external current limit programming resistor can be easily adjusted for this requirement.

Further, the GSM module is typically specified to operate over an input power range that is outside that allowed in the PCMCIA or CompactFlash bus power specification.

The LTC3125 is a high efficiency boost converter with programmable input average current limit that provides the needed flexibility when designing a GSM/GPRS power supply solution. The high efficiency of the converter maximizes the average output power without overloading the bus. A bulk output capacitor is used to supply the energy and maintain the output voltage during the high current pulses.

$V_{IN} > V_{OUT}$ OPERATION

The LTC3125 will maintain voltage regulation even when the input voltage is above the desired output voltage. Note that the efficiency and the maximum output current capability are reduced. Refer to the Typical Performance Characteristics for details.

SHORT-CIRCUIT PROTECTION

The LTC3125 output disconnect feature enables output short circuit protection. To reduce power dissipation under short-circuit conditions; the peak switch current limit is reduced to 800mA (typical).

SCHOTTKY DIODE

Although it is not necessary, adding a Schottky diode from SW to V_{OUT} will improve efficiency by about 4%. Note that this defeats the output disconnect, short-circuit protection and average input limiting during start-up.

PCB LAYOUT GUIDELINES

The high speed operation of the LTC3125 demands careful attention to board layout. A careless layout will result in reduced performance. A large ground pin copper area will help to lower the die temperature. A multilayer board with a separate ground plane is ideal, but not absolutely necessary.

COMPONENT SELECTION

Inductor Selection

The LTC3125 can utilize small surface mount chip inductors due to its fast 1.6MHz switching frequency. Inductor values between 2.2 μ H and 4.7 μ H are suitable for most applications. Larger values of inductance will allow slightly greater output current capability (and lower the Burst Mode threshold) by reducing the inductor ripple current. Increasing the inductance above 10 μ H will increase size while providing little improvement in output current capability. The minimum inductance value is given by:

$$L > \frac{V_{IN(MIN)} \cdot (V_{OUT(MAX)} - V_{IN(MIN)})}{\text{Ripple} \cdot V_{OUT(MAX)} \cdot f_{SW}}$$

where:

Ripple = Allowable inductor current ripple
(amps peak-peak)

$V_{IN(MIN)}$ = Minimum input voltage

$V_{OUT(MAX)}$ = Maximum output voltage

The inductor current ripple is typically set for 20% to 40% of the maximum inductor current. High frequency ferrite core inductor materials reduce frequency dependent power losses compared to cheaper powdered iron types, improving efficiency. The inductor should have low DCR

APPLICATIONS INFORMATION

(DC resistance of the windings) to reduce the I^2R power losses, and must be able to support the peak inductor current without saturating. Molded chokes and some chip inductors usually do not have enough core area to support the peak inductor currents of 1.8A seen on the LTC3125. To minimize radiated noise, use a shielded inductor. See Table 1 for suggested components and suppliers.

Table 1. Recommended Inductors

VENDOR	PART/STYLE
Coilcraft (847) 639-6400 www.coilcraft.com	LPO2506 LPS4012, LPS4018 MSS6122 MSS4020 MOS6020 DS1605, D01608
Coiltronics www.cooperet.com	SD52, SD53, SD3114, SD3118
Murata (714) 852-2001 www.murata.com	LQH55D
Sumida (847) 956-0666 www.sumida	CDH40D11
Taiyo-Yuden www.t-yuden.com	NP04SB NR3015 NR4018
TDK (847) 803-6100 www.component.tdk.com	VLF, LTF VLF, VLCF
Würth (201) 785-8800 www.we-online.com	WE-TPC Type S, M, MH, MS

Output and Input Capacitor Selection

When selecting output capacitors for large pulsed loads, the magnitude and duration of the pulsing current, together with the ripple voltage specification, determine the choice of the output capacitor. Both the ESR of the capacitor and the charge stored in the capacitor each cycle contribute to the output voltage ripple. The ripple due to the charge is approximately:

$$V_{\text{RIPPLE}} \text{ (mV)} = \frac{(I_{\text{PULSE}} - I_{\text{STANDBY}}) \cdot t_{\text{ON}}}{C_{\text{OUT}}}$$

where I_{PULSE} and t_{ON} are the peak current and on time during transmission burst and I_{STANDBY} is the current in

standby mode. The above is a worst-case approximation assuming all the pulsing energy comes from the output capacitor.

The ripple due to the capacitor ESR is:

$$V_{\text{RIPPLE_ESR}} = (I_{\text{PULSE}} - I_{\text{STANDBY}}) \cdot \text{ESR}$$

Low ESR and high capacitance are critical to maintain low output voltage ripple. Typically, two low profile 2200 μF parallel Vishay TANTAMOUNT[®] tantalum, low ESR capacitors are used. The capacitor has less than 40m Ω ESR. These capacitors can be used in parallel for even larger capacitance values. For applications requiring very high capacitance, the GS, GS2 and GW series from Cap-XX, the BestCap[™] series from AVX and PowerStor[®] Aerogel Capacitors from Cooper all offer very high capacitance and low ESR in various package options. Table 2 shows a list of several reservoir capacitor manufacturers.

High capacitance values and low ESR can lead to instability in some internally compensated boost converters. The internal loop compensation of the LTC3125 is optimized to be stable with output capacitor values greater than 500 μF with very low ESR.

Multilayer ceramic capacitors are an excellent choice for input decoupling of the step-up converter as they have extremely low ESR and are available in small footprints. Input capacitors should be located as close as possible to the device. While a 10 μF input capacitor is sufficient for most applications, larger values may be used to reduce input current ripple without limitations. Consult the manufacturers directly for detailed information on their selection of ceramic capacitors. Although ceramic capacitors are recommended, low ESR tantalum capacitors may be used as well.

Table 2. Capacitor Vendor Information

SUPPLIER	PHONE	WEBSITE
Vishay	(402) 563-6866	www.vishay.com
AVX	(803) 448-9411	www.avxcorp.com
Cooper Bussman	(516) 998-4100	www.cooperbussman.com
Cap-XX	(843) 267-0720	www.cap-xx-com
Panasonic	(800) 394-2112	www.panasonic.com

TYPICAL APPLICATIONS

PC Card or CompactFlash (3.3V/500mA Maximum) 4.5V Output, GSM Pulsed Load

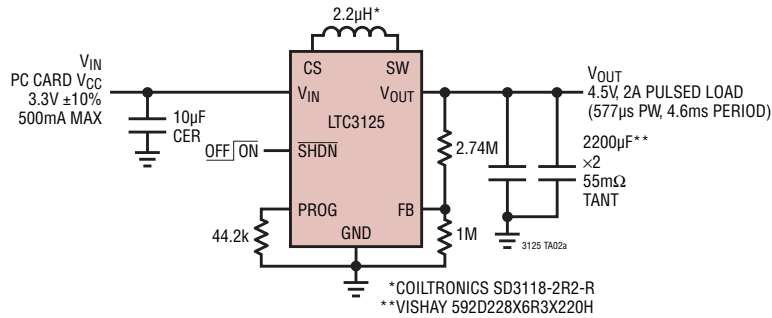

Waveforms of Input Current, V_{OUT} for Pulsed Load Current

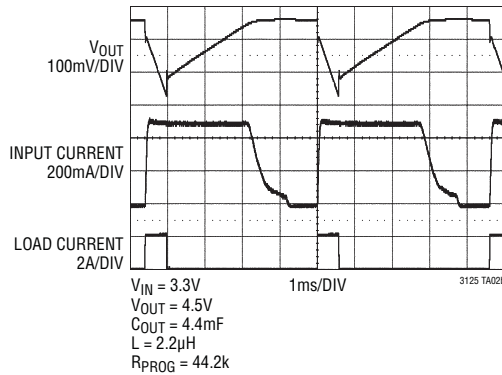

PC Card (3.3V/1000mA Maximum) 4.5V Output, GSM Pulsed Load

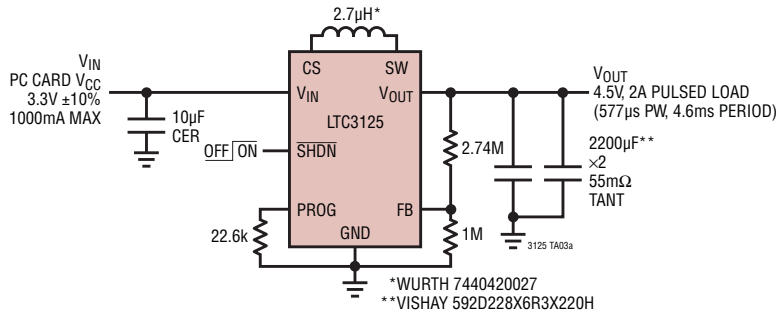

Waveforms of Input Current, V_{OUT} for Pulsed Load Current

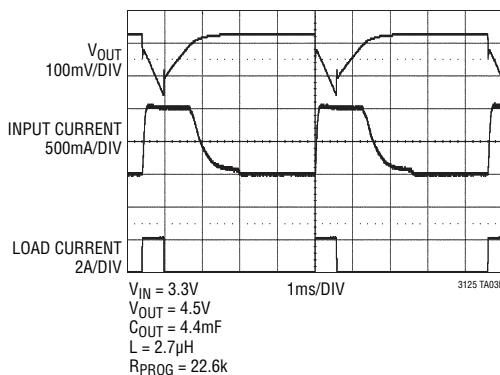

TYPICAL APPLICATIONS

PC Card (3.3V/1000mA Maximum) 4.5V Output, GPRS, Class 10 Pulsed Load

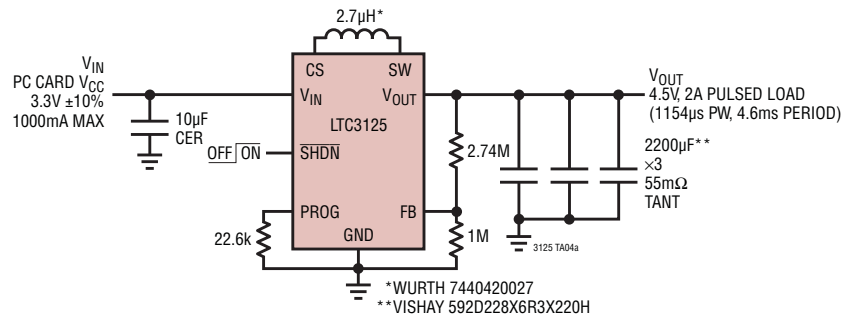

Waveforms of Input Current, V_{OUT} for Pulsed Load Current

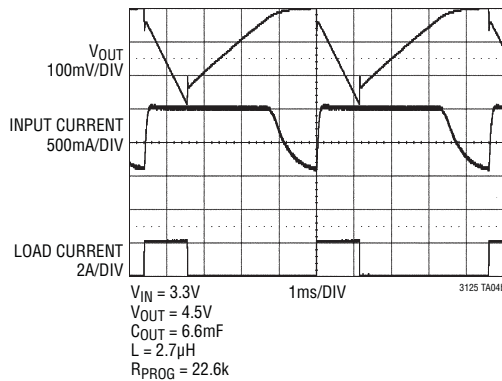

Single Supercap Charger

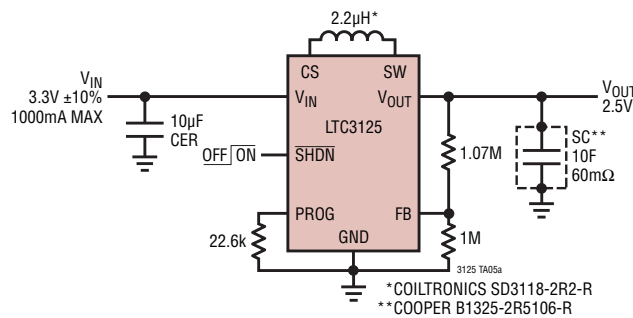

Waveforms of Input Current, V_{OUT} for Pulsed Load Current

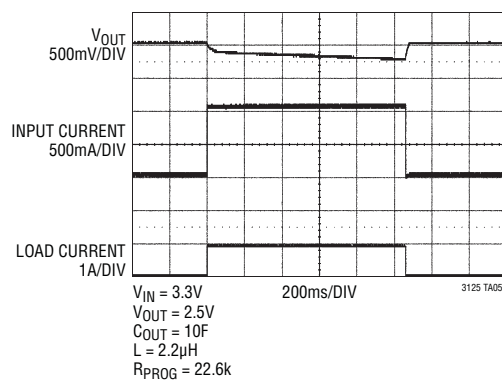

TYPICAL APPLICATIONS

Stacked Supercap Charger

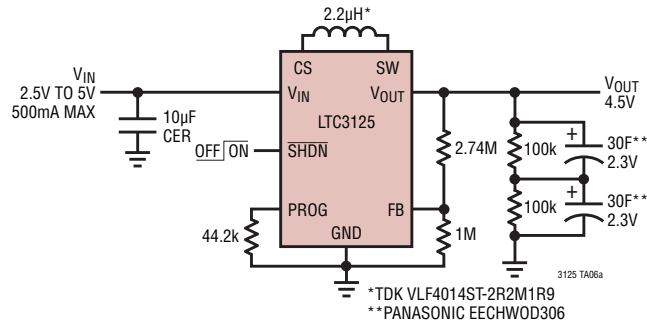

Waveforms of Input Current, V_{OUT} During Charging

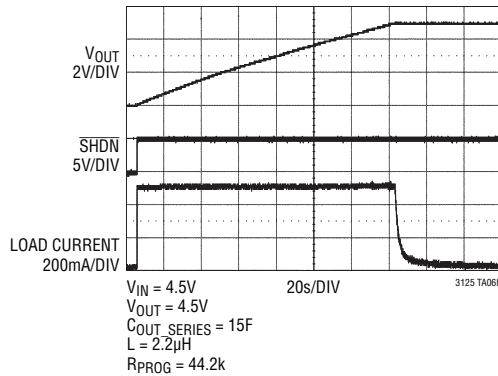

3.3V to 5V with Selectable Input Current Limit

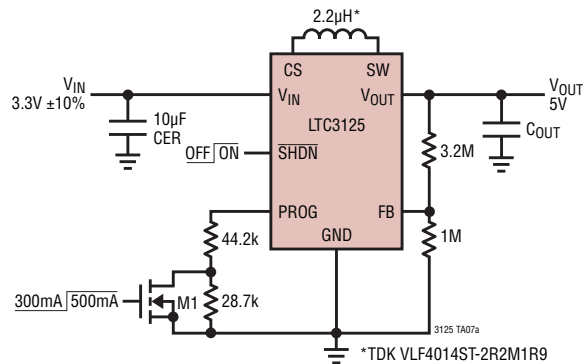

Waveforms of Input Current, V_{OUT} for Pulsed Input Current Limit

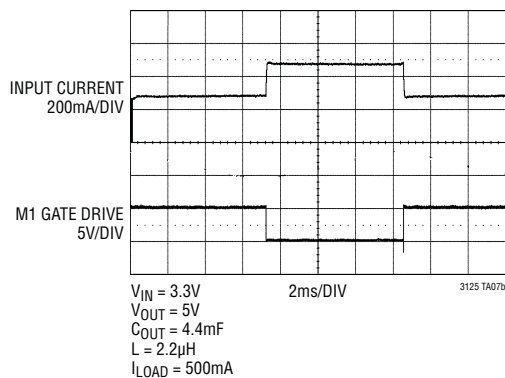

PACKAGE DESCRIPTION

DCB Package 8-Lead Plastic DFN (2mm × 3mm) (Reference LTC DWG # 05-08-1718 Rev A)

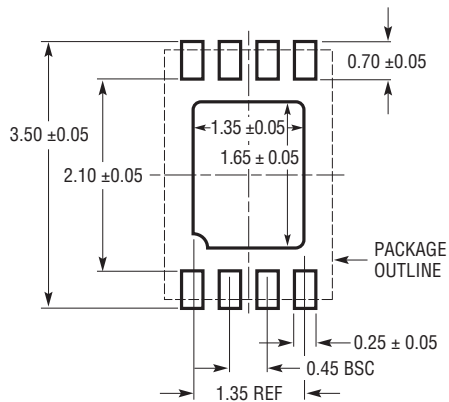

RECOMMENDED SOLDER PAD PITCH AND DIMENSIONS
APPLY SOLDER MASK TO AREAS THAT ARE NOT SOLDERED

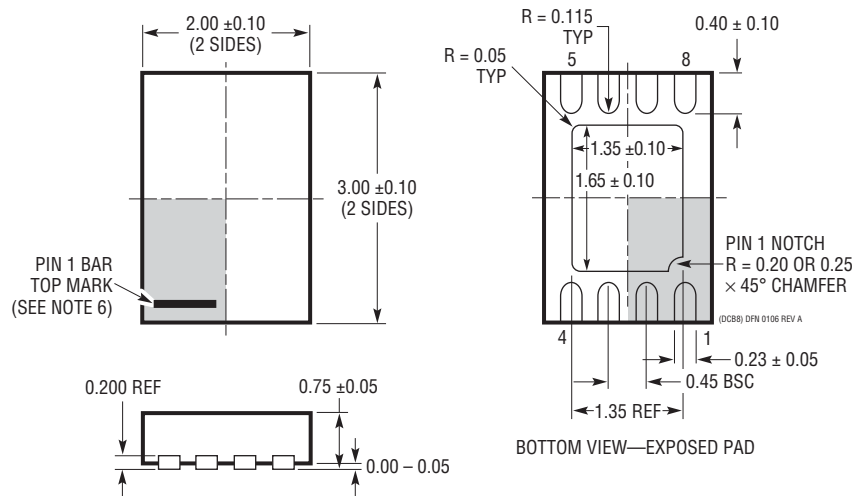

NOTE:

1. DRAWING IS NOT A JEDEC PACKAGE OUTLINE
2. DRAWING NOT TO SCALE
3. ALL DIMENSIONS ARE IN MILLIMETERS
4. DIMENSIONS OF EXPOSED PAD ON BOTTOM OF PACKAGE DO NOT INCLUDE MOLD FLASH. MOLD FLASH, IF PRESENT, SHALL NOT EXCEED 0.15mm ON ANY SIDE
5. EXPOSED PAD SHALL BE SOLDER PLATED
6. SHADED AREA IS ONLY A REFERENCE FOR PIN 1 LOCATION ON THE TOP AND BOTTOM OF PACKAGE

RELATED PARTS

PART NUMBER	DESCRIPTION	COMMENTS
LTC3400/LTC3400B	600mA (I_{SW}), 1.2MHz, Synchronous Step-Up DC/DC Converters	92% Efficiency, V_{IN} : 0.85V to 5V, $V_{OUT(MAX)} = 5V$, $I_Q = 19\mu A/300\mu A$, $I_{SD} < 1\mu A$, ThinSOT™ Package
LTC3421	3A (I_{SW}), 3MHz, Synchronous Step-Up DC/DC Converter with Output Disconnect	94% Efficiency, V_{IN} : 0.85V to 4.5V, $V_{OUT(MAX)} = 5.25V$, $I_Q = 12\mu A$, $I_{SD} < 1\mu A$, 4mm × 4mm QFN24 Package
LTC3422	1.5A (I_{SW}), 3MHz Synchronous Step-Up DC/DC Converter with Output Disconnect	94% Efficiency, V_{IN} : 0.85V to 4.5V, $V_{OUT(MAX)} = 5.25V$, $I_Q = 25\mu A$, $I_{SD} < 1\mu A$, 3mm × 3mm DFN10 Package
LTC3426	2A (I_{SW}), 1.5MHz Step-Up DC/DC Converter	92% Efficiency, V_{IN} : 1.6V to 5.5V, $V_{OUT(MAX)} = 5V$, $I_Q = 600\mu A$, $I_{SD} < 1\mu A$, ThinSOT Package
LTC3427	500mA (I_{SW}), 1.25MHz Synchronous Step-Up DC/DC Converter with Output Disconnect	94% Efficiency, V_{IN} : 1.8V to 5V, $V_{OUT(MAX)} = 5.25V$, $I_Q = 350\mu A$, $I_{SD} < 1\mu A$, 2mm × 2mm DFN6 Package
LTC3429/LTC3429B	600mA (I_{SW}), 500kHz, Synchronous Step-Up DC/DC Converter with Output Disconnect and Soft-Start	96% Efficiency, V_{IN} : 0.85V to 4.3V, $V_{OUT(MAX)} = 5V$, $I_Q = 20\mu A$, $I_{SD} < 1\mu A$, ThinSOT Package
LTC3458/LTC3458L	1.4A/1.7A (I_{SW}), 1.5MHz Synchronous Step-Up DC/DC Converter	94% Efficiency V_{IN} : 0.85V to 6V, $V_{OUT(MAX)} = 7.5V/6V$, $I_Q = 15\mu A$, $I_{SD} < 1\mu A$, 3mm × 4mm DFN12 Package
LTC3459	80mA (I_{SW}), Synchronous Step-Up DC/DC Converter	92% Efficiency, V_{IN} : 1.5V to 5.5V, $V_{OUT(MAX)} = 10V$, $I_Q = 10\mu A$, $I_{SD} < 1\mu A$, ThinSOT Package
LT3494/LT3494A	180mA/350mA (I_{SW}), High Efficiency Step-Up DC/DC Converters with Output Disconnect	85% Efficiency, V_{IN} : 2.3V to 16V, $V_{OUT(MAX)} = 38V$, $I_Q = 65\mu A$, $I_{SD} < 1\mu A$, 2mm × 3mm DFN6, ThinSOT Packages
LTC3523/LTC3523-2	600mA (I_{SW}), Step-Up and 400MHz Synchronous Step-Down 1.2MHz/2.4MHz DC/DC Converter with Output Disconnect	94% Efficiency V_{IN} : 1.8V to 5.5V, $V_{OUT(MAX)} = 5.25V$, $I_Q = 45\mu A$, $I_{SD} < 1\mu A$, 3mm × 3mm QFN16 Package
LTC3525-3/ LTC3525-3.3/ LTC3525-5	400mA (I_{SW}), Micropower Synchronous Step-Up DC/DC Converter with Output Disconnect	94% Efficiency, V_{IN} : 0.85V to 4V, $V_{OUT(MAX)} = 5V$, $I_Q = 7\mu A$, $I_{SD} < 1\mu A$, SC-70 Package
LTC3526/LTC3526L LTC3526B	500mA (I_{SW}), 1MHz Synchronous Step-Up DC/DC Converter with Output Disconnect	94% Efficiency V_{IN} : 0.85V to 5V, $V_{OUT(MAX)} = 5.25V$, $I_Q = 9\mu A$, $I_{SD} < 1\mu A$, 2mm × 2mm DFN6 Package
LTC3527/LTC3527-1	Dual 800mA/400mA (I_{SW}), 2.2MHz Synchronous Step-Up DC/DC Converter with Output Disconnect	94% Efficiency V_{IN} : 0.7V to 5V, $V_{OUT(MAX)} = 5.25V$, $I_Q = 12\mu A$, $I_{SD} < 1\mu A$, 3mm × 3mm QFN16 Package
LTC3528/LTC3528B	1A (I_{SW}), 1MHz Synchronous Step-Up DC/DC Converter with Output Disconnect	94% Efficiency V_{IN} : 0.7V to 5.5V, $V_{OUT(MAX)} = 5.25V$, $I_Q = 12\mu A$, $I_{SD} < 1\mu A$, 2mm × 3mm DFN8 Package
LTC3537	600mA (I_{SW}), 2.2MHz Synchronous Step-Up DC/DC Converter with Output Disconnect and 100mA LDO	94% Efficiency V_{IN} : 0.7V to 5V, $V_{OUT(MAX)} = 5.25V$, $I_Q = 30\mu A$, $I_{SD} < 1\mu A$, 3mm × 3mm QFN16 Package
LTC3539/LTC3539-2	2A (I_{SW}), 1MHz, 2.2MHz Synchronous Step-Up DC/DC Converter with Output Disconnect	94% Efficiency, V_{IN} : 0.7V to 5V, $V_{OUT(MAX)} = 5.25V$, $I_Q = 10\mu A$, $I_{SD} < 1\mu A$, 2mm × 3mm DFN Package