



Product Change Notification / SYST-29BFHE416

Date:

30-Mar-2022

Product Category:

General Purpose LED Drivers

PCN Type:

Document Change

Notification Subject:

Data Sheet - HV9961 LED Driver with Average-Current Mode Constant-Current Control Data Sheet
Document Revision

Affected CPNs:

[SYST-29BFHE416_Affected_CPN_03302022.pdf](#)
[SYST-29BFHE416_Affected_CPN_03302022.csv](#)

Notification Text:

SYST-29BFHE416

Microchip has released a new Product Documents for the HV9961 LED Driver with Average-Current Mode Constant-Current Control Data Sheet of devices. If you are using one of these devices please read the document located at [HV9961 LED Driver with Average-Current Mode Constant-Current Control Data Sheet](#).

Notification Status: Final

Description of Change:

- 1) Changed package drawings.
- 2) Updated Section "Electrical Characteristics".
- 3) Updated Section "Temperature Specifications".
- 4) Minor format changes throughout.

Impacts to Data Sheet: See above details.

Reason for Change: To Improve Productivity

Change Implementation Status: Complete

Date Document Changes Effective: 30 March 2022

NOTE: Please be advised that this is a change to the document only the product has not been changed.

Markings to Distinguish Revised from Unrevised Devices: N/A

Attachments:

[HV9961 LED Driver with Average-Current Mode Constant-Current Control Data Sheet](#)

Please contact your local [Microchip sales office](#) with questions or concerns regarding this notification.

Terms and Conditions:

If you wish to [receive Microchip PCNs via email](#) please register for our PCN email service at our [PCN home page](#) select register then fill in the required fields. You will find instructions about registering for Microchips PCN email service in the [PCN FAQ](#) section.

If you wish to [change your PCN profile, including opt out](#), please go to the [PCN home page](#) select login and sign into your myMicrochip account. Select a profile option from the left navigation bar and make the applicable selections.

Affected Catalog Part Numbers (CPN)

HV9961LG-G

HV9961NG-G

HV9961NG-G-M901

HV9961NG-G-M934

LED Driver with Average-Current Mode Constant-Current Control

Features

- Fast Average Current Control
- Programmable Constant Off-time Switching
- Linear Dimming Input
- PWM Dimming Input
- Output Short-circuit Protection with Skip Mode
- -40°C to +125°C Ambient Operating Temperature
- Pin-compatible with HV9910B

Applications

- DC/DC or AC/DC LED Driver Applications
- LED Backlight Driver for LCD Displays
- General Purpose Constant-current Source
- LED Signage and Displays
- Architectural and Decorative LED Lighting
- LED Street Lighting

General Description

The HV9961 is an Average-Current mode constant-current control LED driver IC operating in a constant Off-time mode. Unlike the HV9910B, this control IC does not produce a peak-to-average error. This greatly improves accuracy as well as the line and load regulations of the LED current without any need for loop compensation or high-side current sensing. Its output LED current accuracy is $\pm 3\%$.

The IC is equipped with a current limit comparator for Hiccup mode output short-circuit protection.

The HV9961 can be powered from an 8V–450V supply. It has a PWM dimming input that accepts an external control TTL-compatible signal. In addition, the output current can be programmed by an internal 275 mV reference or controlled externally through a 0V–1.5V linear dimming input.

The HV9961 is pin-to-pin compatible with HV9910B, and it can be used as a drop-in replacement for many applications to improve LED current accuracy and regulation.

Package Types

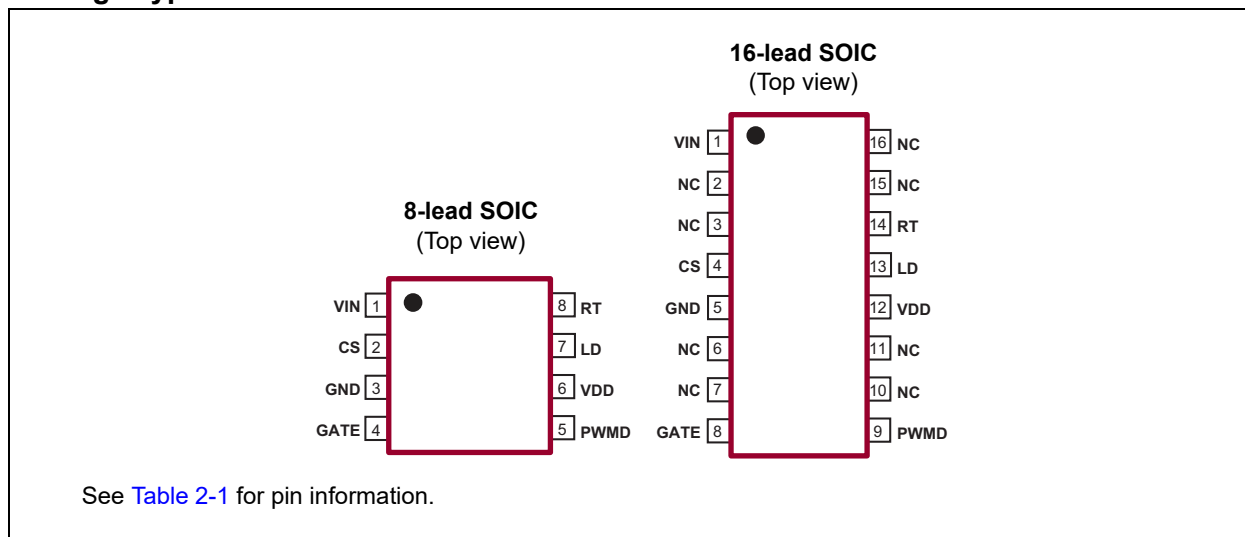

HV9961

Functional Block Diagram

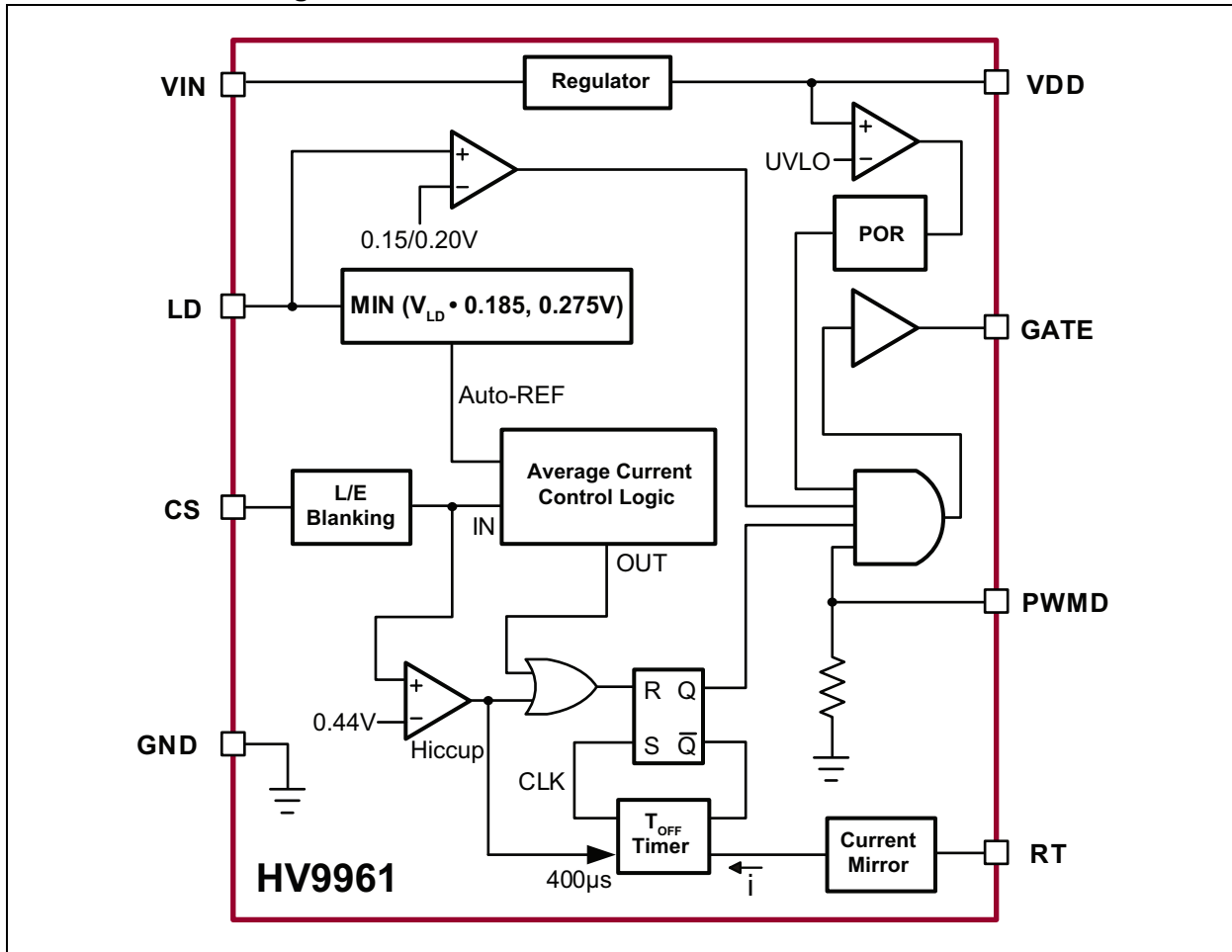

Typical Application Circuit

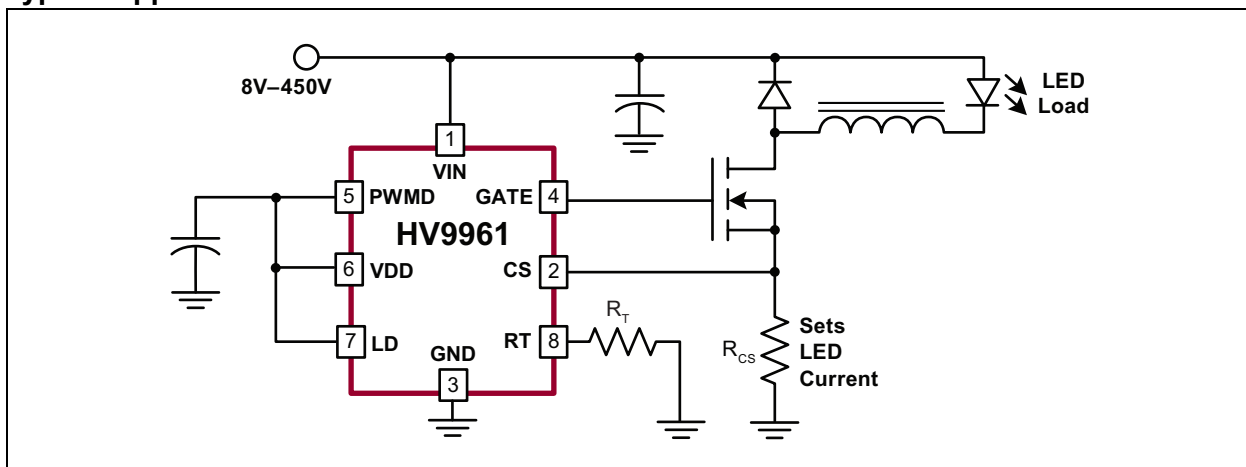

1.0 ELECTRICAL CHARACTERISTICS

Absolute Maximum Ratings†

V_{IN} to GND	-0.5V to +470V
V_{DD} to GND	+12V
CS, LD, PWMD, Gate, RT to GND.....	-0.3V to $V_{DD}+0.3V$
Continuous Power Dissipation ($T_A = +25^\circ\text{C}$):	
8-lead SOIC	650 mW
16-lead SOIC	1000 mW

† **Notice:** Stresses above those listed under “Absolute Maximum Ratings” may cause permanent damage to the device. This is a stress rating only, and functional operation of the device at those or any other conditions above those indicated in the operational sections of this specification is not intended. Exposure to maximum rating conditions for extended periods may affect device reliability.

ELECTRICAL CHARACTERISTICS

Electrical Specifications: $T_A = 25^\circ\text{C}$, $V_{IN} = 12V$, $V_{LD} = V_{DD}$, and $V_{PWMD} = V_{DD}$ unless otherwise specified.

Parameter	Sym.	Min.	Typ.	Max.	Unit	Conditions
INPUT						
Input DC Supply Voltage Range	V_{INDC}	8	—	450	V	DC input voltage (Note 1 and Note 2)
Shutdown Mode Supply Current	I_{INSD}	—	0.5	1	mA	Pin PWMD connected to GND (Note 2)
INTERNAL REGULATOR						
Internally Regulated Voltage	V_{DD}	7.25	7.5	7.75	V	$V_{IN} = 8V$, $I_{DD(EXT)} = 0\text{ mA}$, 500 pF at gate, $R_T = 226\text{ k}\Omega$
Line Regulation of V_{DD}	$\Delta V_{DD, \text{line}}$	0	—	1	V	$V_{IN} = 8V-450V$, $I_{DD(EXT)} = 0\text{ mA}$, 500 pF at gate, $R_T = 226\text{ k}\Omega$
Load Regulation of V_{DD}	$\Delta V_{DD, \text{load}}$	0	—	100	mV	$I_{DD(EXT)} = 0\text{ mA}-1\text{ mA}$, 500 pF at gate, $R_T = 226\text{ k}\Omega$
V_{DD} Undervoltage Lockout Upper Threshold	V_{UVLO}	6.45	6.7	6.95	V	V_{IN} rising (Note 2)
V_{DD} Undervoltage Lockout Hysteresis	ΔV_{UVLO}	—	500	—	mV	V_{IN} falling
Maximum Input Current (Limited by UVLO)	$I_{IN, \text{MAX}}$	3.5	—	—	mA	$V_{IN} = 8V$, $T_A = 25^\circ\text{C}$ (Note 3)
		1.5	—	—		$V_{IN} = 8V$, $T_A = 125^\circ\text{C}$ (Note 3)
PWM DIMMING						
PWMD Input Low Voltage	$V_{PWMD(LO)}$	—	—	0.8	V	$V_{IN} = 8V-450V$ (Note 2)
PWMD Input High Voltage	$V_{PWMD(HI)}$	2.2	—	—	V	$V_{IN} = 8V-450V$ (Note 2)
PWMD Pull-down Resistance	R_{PWMD}	50	100	150	k Ω	$V_{PWMD} = 5V$
AVERAGE-CURRENT SENSE LOGIC						
Current Sense Reference Voltage	V_{CST}	264	275	286	mV	$V_{LD} = 1.5V$
LD-to-CS Voltage Ratio	$A_{V(LD)}$	0.178	0.185	0.188	—	$V_{LD} = 1.2V$
LD-to-CS Voltage Offset	$A_V \times V_{LD(OFFSET)}$	-15	—	15	mV	Offset = $V_{CS} - A_{V(LD)} \times V_{LD}$, $V_{LD} = 1.2V$
CS Threshold Temperature Regulation	$\Delta V_{CST(TEMP)}$	—	—	5	mV	(Note 2)

Note 1: Also limited by package power dissipation limit, whichever is lower

2: Denotes specifications which apply over the full operating ambient temperature range of $-40^\circ\text{C} < T_A < +125^\circ\text{C}$

3: Specification is obtained by characterization and is not 100% tested.

HV9961

ELECTRICAL CHARACTERISTICS (CONTINUED)

Electrical Specifications: $T_A = 25^\circ\text{C}$, $V_{IN} = 12\text{V}$, $V_{LD} = V_{DD}$, and $V_{PWMD} = V_{DD}$ unless otherwise specified.						
Parameter	Sym.	Min.	Typ.	Max.	Unit	Conditions
LD Input Shutdown Threshold Voltage	$V_{LD(OFF)}$	—	150	—	mV	V_{LD} falling
LD Input Enable Threshold Voltage	$V_{LD(EN)}$	—	200	—	mV	V_{LD} rising
Current Sense Blanking Interval	T_{BLANK}	150	—	340	ns	(Note 2)
Minimum On-time	$T_{ON(MIN)}$	—	—	1000	ns	$V_{CS} = V_{CST} + 30\text{ mV}$
Maximum Steady-state Duty Cycle	D_{MAX}	75	—	—	%	Reduction in output LED current may occur beyond this duty cycle
SHORT-CIRCUIT PROTECTION						
Hiccup Threshold Voltage	V_{CSH}	410	440	470	mV	
Current Limit Delay CS-to-Gate	T_{DELAY}	—	—	185	ns	$V_{CS} = V_{CSH} + 30\text{ mV}$
Short-circuit Hiccup Time	T_{HICCUP}	350	400	550	μs	
Minimum On-time (Short-circuit)	$T_{ON(MIN),SC}$	—	—	430	ns	$V_{CS} = V_{DD}$
T_{OFF} TIMER						
Off-time	T_{OFF}	32	40	48	μs	$R_T = 1\text{ M}\Omega$
		8	10	12		$R_T = 226\text{ k}\Omega$
GATE DRIVER						
Gate Sourcing Current	I_{SOURCE}	0.165	—	—	A	$V_{GATE} = 0\text{V}$, $V_{DD} = 7.5\text{V}$
Gate Sinking Current	I_{SINK}	0.165	—	—	A	$V_{GATE} = V_{DD}$, $V_{DD} = 7.5\text{V}$
Gate Output Rise Time	t_r	—	30	50	ns	$C_{GATE} = 500\text{ pF}$, $V_{DD} = 7.5\text{V}$
Gate Output Fall Time	t_f	—	30	50	ns	$C_{GATE} = 500\text{ pF}$, $V_{DD} = 7.5\text{V}$

Note 1: Also limited by package power dissipation limit, whichever is lower

2: Denotes specifications which apply over the full operating ambient temperature range of $-40^\circ\text{C} < T_A < +125^\circ\text{C}$

3: Specification is obtained by characterization and is not 100% tested.

TEMPERATURE SPECIFICATIONS

Parameter	Sym.	Min.	Typ.	Max.	Unit	Conditions
TEMPERATURE RANGES						
Operating Ambient Temperature	T_A	-40	—	+125	$^\circ\text{C}$	
Junction Temperature	T_J	-40	—	+150	$^\circ\text{C}$	
Storage Temperature	T_S	-65	—	+150	$^\circ\text{C}$	
PACKAGE THERMAL RESISTANCE						
8-lead SOIC	θ_{JA}	—	101	—	$^\circ\text{C/W}$	
16-lead SOIC	θ_{JA}	—	83	—	$^\circ\text{C/W}$	

2.0 PIN DESCRIPTION

The details on the pins of HV9961 are listed on [Table 2-1](#). Refer to [Package Types](#) for the location of pins.

TABLE 2-1: PIN FUNCTION TABLE

Pin Number		Pin Name	Description
8-lead SOIC	16-lead SOIC		
1	1	VIN	This pin is the input of an 8V–450V linear regulator.
2	4	CS	This pin is the current sense pin used to sense the FET current with an external sense resistor.
3	5	GND	Ground return for all internal circuitry. This pin must be electrically connected to the ground of the power train.
4	8	Gate	This pin is the output of gate driver for driving an external N-channel power MOSFET.
5	9	PWMD	This is the PWM dimming input of the IC. When this pin is pulled to GND, the gate driver is turned off. When the pin is pulled high, the gate driver operates normally.
6	12	V _{DD}	This is the power supply pin for all internal circuits. It must be bypassed with a low ESR capacitor to GND (at least 0.1 μ F).
7	13	LD	This pin is the linear dimming input, and it sets the current sense threshold as long as the voltage at this pin is less than 1.5V. If voltage at LD falls below 150 mV, the gate output is disabled. The gate signal recovers at 200 mV at LD.
8	14	RT	A resistor connected between this pin and GND programs the gate off-time.
—	2, 3, 6, 7, 10, 11, 15, 16	NC	No connection.

3.0 APPLICATION INFORMATION

3.1 General Description

Peak current control (as in HV9910B) is the simplest and the most economical way to regulate a buck converter's output current. However, it suffers accuracy and regulation problems that arise from peak-to-average current error, contributed by the current ripple in the output inductor and the propagation delay in the current sense comparator. The full inductor current signal is unavailable for direct switch current sensing across the sense resistor at the ground path in this low-side switch buck converter when the control switch is at the ground potential because the switch is turned off. While it is very simple to detect the peak current in the switch, controlling the average inductor current is usually implemented by level translating the sense signal from $+V_{IN}$. Although this is practical for a relatively low-input voltage, V_{IN} , this type of average-current control may become excessively complex and expensive in the offline AC or other high-voltage DC applications.

The HV9961 uses a proprietary control scheme that allows fast and accurate control of the average current in the buck inductor by sensing the switch current only. No compensation of the current control loop is required. The output LED current's response to PWM input is similar to that of the HV9910B. The effect of inductor current ripple amplitude on this control scheme is insignificant. Therefore, the LED current is independent of the variation in inductance, switching frequency or output voltage. Constant off-time control of the buck converter is used for stability and improving the LED current regulation over a wide range of input voltages. Unlike HV9910B, the HV9961 does not support Constant Frequency mode.

3.2 Off Timer

The timing resistor connected between RT and GND determines the off-time of the gate driver. Wiring this resistor between RT and Gate as with HV9910B is no longer supported. Refer to [Equation 3-1](#) for the computation of the gate output's off-time.

EQUATION 3-1:

$$T_{OFF}(\mu s) = \frac{R_T(k\Omega)}{25} + 0.3$$

within the range of $30\text{ k}\Omega \leq R_T \leq 1\text{ M}\Omega$

3.3 Average-Current Control Feedback and Output Short-circuit Protection

The current through the switching Metal-oxide Semiconductor Field-effect Transistor (MOSFET) source is averaged and used to give constant-current feedback. This current is detected with a sense resistor at the CS pin. The feedback operates in a fast Open-loop mode. No compensation is required. Output current is programmed as seen in [Equation 3-2](#).

EQUATION 3-2:

$$I_{LED} = \frac{0.275V}{R_{CS}}$$

When the voltage at the LD input $V_{LD} \geq 1.5V$

If the voltage at the LD input is less than 1.5V, the output current is computed as specified in [Equation 3-3](#).

EQUATION 3-3:

$$I_{LED} = \frac{V_{LD} \times 0.185}{R_{CS}}$$

When the voltage at the LD input $0.2V \leq V_{LD} < 1.5V$

The above equations are only valid for continuous conduction of the output inductor. It is good design practice to choose the inductance of the inductor such that the peak-to-peak inductor current is 30% to 40% of the average DC full-load current. Hence, the recommended inductance can be calculated as shown in [Equation 3-4](#).

EQUATION 3-4:

$$L_O = \frac{V_{O(MAX)} \times T_{OFF}}{0.4 \times I_O}$$

The duty-cycle range of the current control feedback is limited to $D \leq 0.75$. A reduction in the LED current may occur when the desired LED string voltage V_O is greater than 75% of the input voltage V_{IN} of the HV9961 LED driver.

Reducing the targeted output LED string voltage V_O below $V_{O(MIN)} = V_{IN} \times D_{MIN}$, where $D_{MIN} = 1\ \mu s / (T_{OFF} + 1\ \mu s)$, may also result in the loss of regulation of the LED current. This condition, however, causes an increase in the LED current and can potentially trip the short-circuit protection comparator.

The typical output characteristic of the HV9961 LED driver is shown in [Figure 3-1](#). The corresponding HV9910B characteristic is given for the comparison.

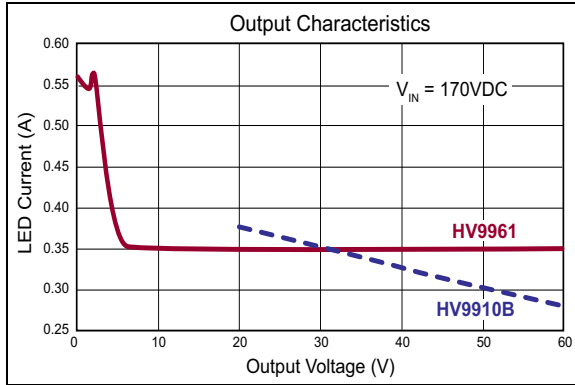

FIGURE 3-1: Typical Output Characteristic of an HV9961 LED Driver.

The short-circuit protection comparator trips when the voltage at CS exceeds $0.44V$. When this occurs, the short-circuit gate off-time $T_{HICCUP} = 400 \mu s$ is generated to prevent the staircasing of the inductor current and, potentially, its saturation due to insufficient output voltage. The typical short-circuit inductor current is shown in the waveform of Figure 3-2.

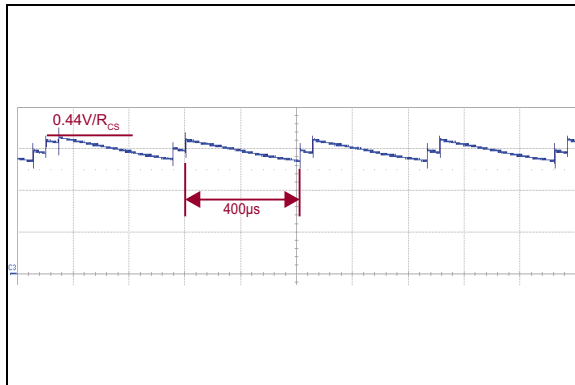

FIGURE 3-2: Short-circuit Inductor Current.

A leading-edge blanking delay is provided at CS to prevent false triggering of the current feedback and the short-circuit protection.

3.4 Linear Dimming

When the voltage at LD falls below $1.5V$, the internal 275 mV reference to the constant-current feedback becomes overridden by $V_{LD} \times 0.185$. As long as the current in the inductor remains continuous, the LED current is given by Equation 3-3. However, when V_{LD} falls below 150 mV , the gate output becomes disabled. The gate signal recovers when V_{LD} exceeds 200 mV . It is required in some applications to use the same brightness control signal input to shut off the lamp. The typical linear dimming response is shown in Figure 3-3.

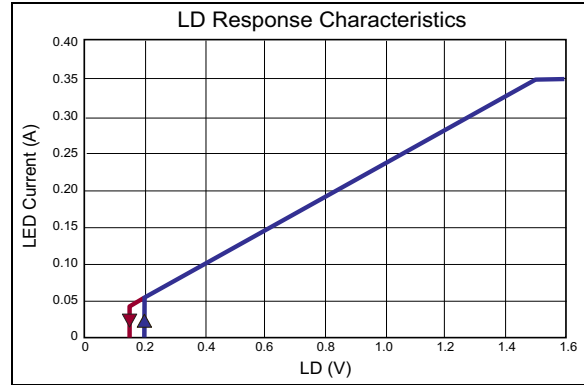

FIGURE 3-3: Typical Linear Dimming Response of an HV9961 LED Driver.

The linear dimming input could also be used for “mixed-mode” dimming to expand the dimming ratio. In such case, a pulse-width modulated signal with an amplitude below $1.5V$ should be applied to LD.

3.5 Input Voltage Regulator

The HV9961 can be powered directly from an $8 V_{DC} - 450 V_{DC}$ supply through its V_{IN} input. When this voltage is applied at the V_{IN} pin, the HV9961 maintains a constant $7.5V$ level at V_{DD} . This voltage can be used to power the IC and external circuitry connected to V_{DD} within the rated maximum current or within the thermal ratings of the package, whichever limit is lower. The V_{DD} pin must be bypassed by a low ESR capacitor to provide a low-impedance path for the high-frequency current of the gate output. The HV9961 can also be powered through the V_{DD} pin directly with a voltage greater than the internally regulated $7.5V$, but less than $12V$.

Despite the instantaneous voltage rating of $450V$, continuous voltage at V_{IN} is limited by the power dissipation in the package. For example, when HV9961 draws $I_{IN} = 2.5 \text{ mA}$ from the V_{IN} input, and the 8-pin SOIC package is used, the maximum continuous voltage at V_{IN} is limited to the value shown in Equation 3-5.

EQUATION 3-5:

$$V_{IN(MAX)} = \frac{T_{J(MAX)} - T_A}{R_{\theta,JA} \times I_{IN}} = 396V$$

Where:

Ambient temperature: $T_A = 25^\circ C$

Maximum working junction temperature: $T_{J(MAX)} = 125^\circ C$

Junction-to-ambient thermal resistance:

$R_{\theta,JA} = 101^\circ C/W$

HV9961

In such cases, when it is needed to operate the HV9961 from a higher voltage, a resistor or a Zener diode can be added in series with the V_{IN} input to divert some of the power loss from the HV9961. In the above example, using a 100V Zener diode will allow the circuit to work up to 490V. The input current drawn from the V_{IN} pin is represented by Equation 3-6.

EQUATION 3-6:

$$I_{IN} \approx I_{mA} + Q_G \times f_S$$

Where:

f_S = Switching frequency

Q_G = Gate charge of the external FET (obtained from the manufacturer's data sheet)

3.6 Gate Output

The gate output of the HV9961 is used to drive an external MOSFET. It is recommended that the gate charge Q_G of the external MOSFET be less than 25 nC for switching frequencies ≤ 100 kHz and less than 15 nC for switching frequencies > 100 kHz.

3.7 PWM Dimming

Due to the fast open-loop response of the average-current control loop of the HV9961, its PWM dimming performance nearly matches that of the HV9910B. The inductor current waveform comparison is shown in Figure 3-4.

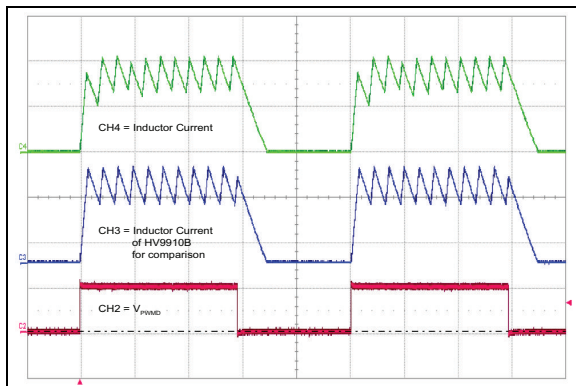

FIGURE 3-4: Typical PWM Dimming Response of an HV9961 LED Driver.

The rising and falling edges are limited by the current slew rate in the inductor. The first switching cycle is terminated upon reaching the 275 mV or $V_{LD} \times 0.185$ level at CS. The circuit is further reaching its steady-state within 3–4 switching cycles regardless of the switching frequency.

4.0 PACKAGING INFORMATION

4.1 Package Marking Information

8-lead SOIC

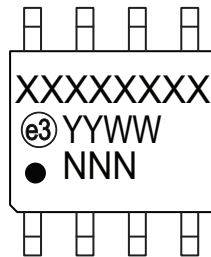

Example

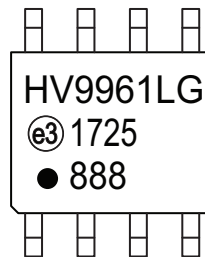

16-lead SOIC

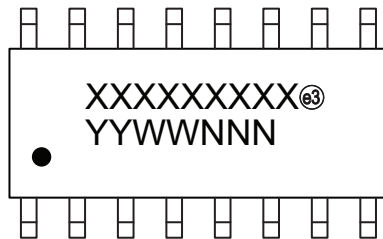

Example



Legend:	XX...X	Product code or customer-specific information
	Y	Year code (last digit of calendar year)
	YY	Year code (last 2 digits of calendar year)
	WW	Week code (week of January 1 is week '01')
	NNN	Alphanumeric traceability code
	(e3)	Pb-free JEDEC® designator for Matte Tin (Sn)
	*	This package is Pb-free. The Pb-free JEDEC designator (e3) can be found on the outer packaging for this package.
	●, ▲, ▼	Pin one index is identified by a dot, delta up, or delta down (triangle mark).
Note:	In the event the full Microchip part number cannot be marked on one line, it will be carried over to the next line, thus limiting the number of available characters for customer-specific information. Package may or may not include the corporate logo.	
	Underbar (¯) and/or Overbar (¯) symbol may not be to scale.	

HV9961

8-Lead Plastic Small Outline (SN) - Narrow, 3.90 mm (.150 In.) Body [SOIC]

Note: For the most current package drawings, please see the Microchip Packaging Specification located at <http://www.microchip.com/packaging>

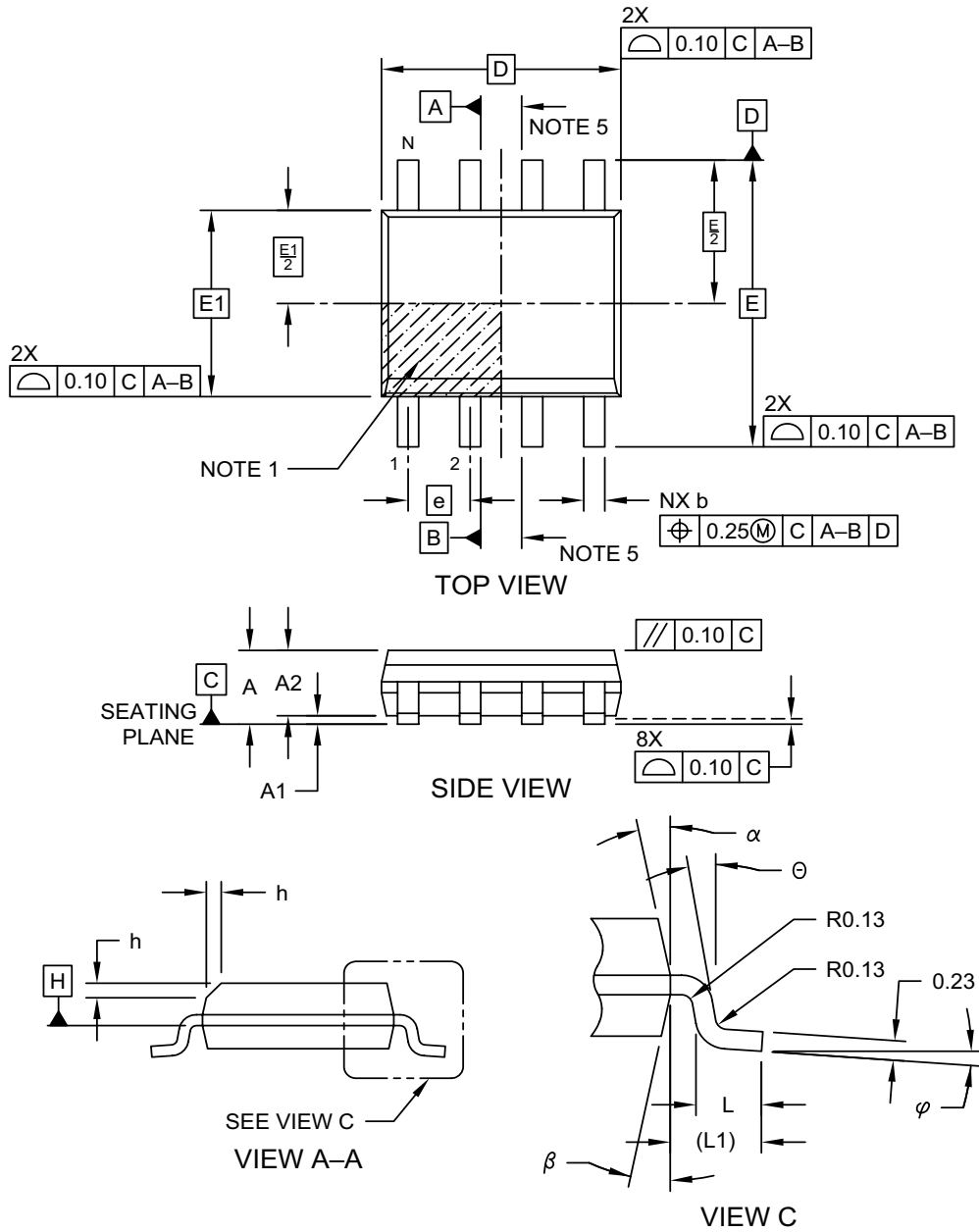

Microchip Technology Drawing No. C04-057-SN Rev F Sheet 1 of 2

8-Lead Plastic Small Outline (SN) - Narrow, 3.90 mm (.150 In.) Body [SOIC]

Note: For the most current package drawings, please see the Microchip Packaging Specification located at <http://www.microchip.com/packaging>

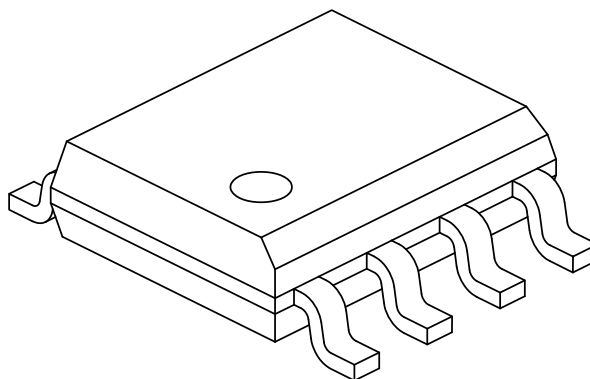

Dimension Limits	Units	MILLIMETERS		
		MIN	NOM	MAX
Number of Pins	N	8		
Pitch	e	1.27 BSC		
Overall Height	A	-	-	1.75
Molded Package Thickness	A2	1.25	-	-
Standoff §	A1	0.10	-	0.25
Overall Width	E	6.00 BSC		
Molded Package Width	E1	3.90 BSC		
Overall Length	D	4.90 BSC		
Chamfer (Optional)	h	0.25	-	0.50
Foot Length	L	0.40	-	1.27
Footprint	L1	1.04 REF		
Foot Angle	φ	0°	-	8°
Lead Thickness	c	0.17	-	0.25
Lead Width	b	0.31	-	0.51
Mold Draft Angle Top	α	5°	-	15°
Mold Draft Angle Bottom	β	5°	-	15°

Notes:

- Pin 1 visual index feature may vary, but must be located within the hatched area.
- § Significant Characteristic
- Dimensions D and E1 do not include mold flash or protrusions. Mold flash or protrusions shall not exceed 0.15mm per side.
- Dimensioning and tolerancing per ASME Y14.5M
BSC: Basic Dimension. Theoretically exact value shown without tolerances.
REF: Reference Dimension, usually without tolerance, for information purposes only.
- Datums A & B to be determined at Datum H.

Microchip Technology Drawing No. C04-057-SN Rev F Sheet 2 of 2

8-Lead Plastic Small Outline (SN) - Narrow, 3.90 mm (.150 In.) Body [SOIC]

Note: For the most current package drawings, please see the Microchip Packaging Specification located at <http://www.microchip.com/packaging>

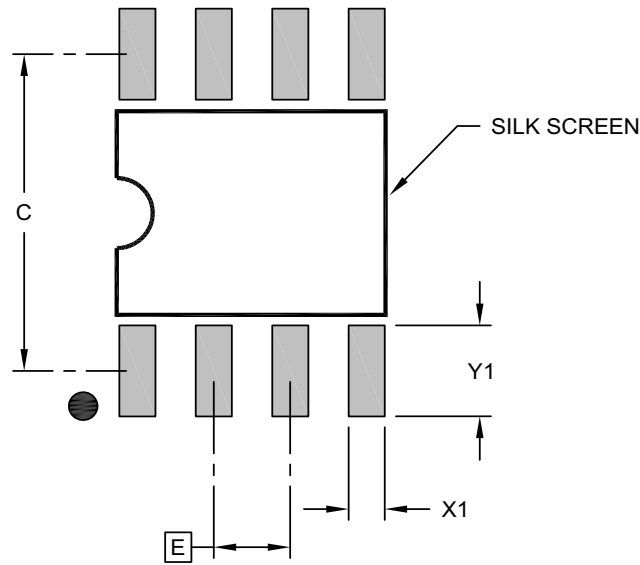

RECOMMENDED LAND PATTERN

Dimension Limits	Units	MILLIMETERS		
		MIN	NOM	MAX
Contact Pitch	E	1.27 BSC		
Contact Pad Spacing	C		5.40	
Contact Pad Width (X8)	X1			0.60
Contact Pad Length (X8)	Y1			1.55

Notes:

1. Dimensioning and tolerancing per ASME Y14.5M

BSC: Basic Dimension. Theoretically exact value shown without tolerances.

Microchip Technology Drawing C04-2057-SN Rev F

16-Lead Plastic Small Outline (SL) - Narrow, 3.90 mm Body [SOIC]

Note: For the most current package drawings, please see the Microchip Packaging Specification located at <http://www.microchip.com/packaging>

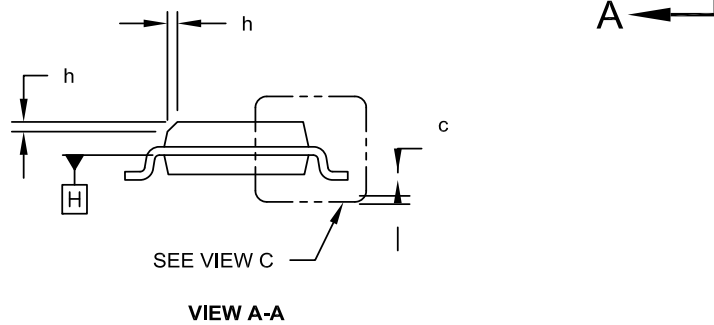
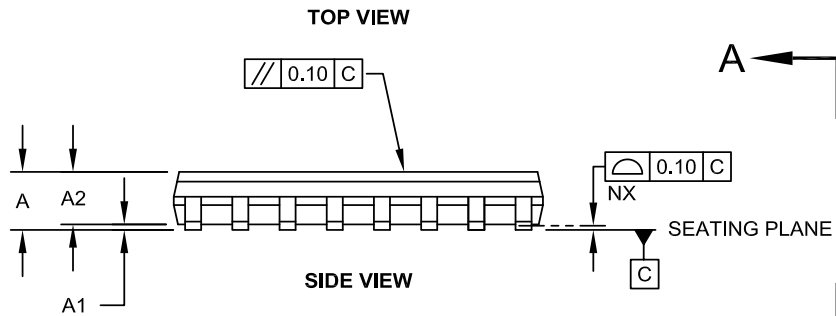
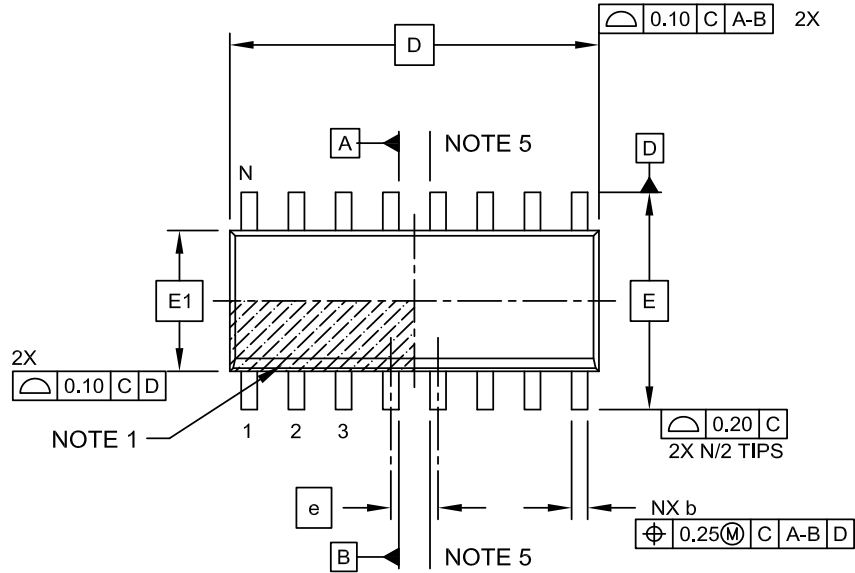

Microchip Technology Drawing No. C04-108C Sheet 1 of 2

16-Lead Plastic Small Outline (SL) - Narrow, 3.90 mm Body [SOIC]

Note: For the most current package drawings, please see the Microchip Packaging Specification located at <http://www.microchip.com/packaging>

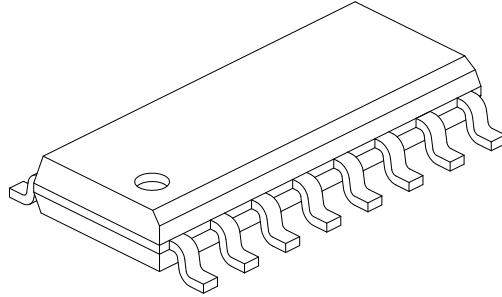
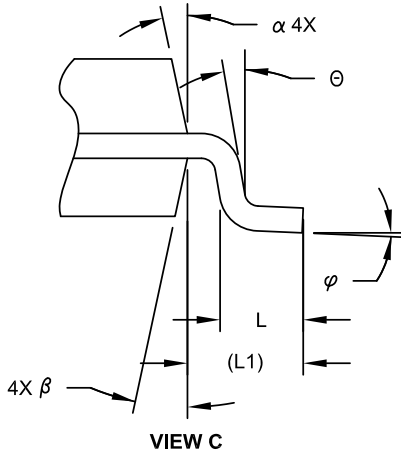

Dimension Limits	Units	MILLIMETERS		
		MIN	NOM	MAX
Number of Pins	N	16		
Pitch	e	1.27 BSC		
Overall Height	A	-	-	1.75
Molded Package Thickness	A2	1.25	-	-
Standoff §	A1	0.10	-	0.25
Overall Width	E	6.00 BSC		
Molded Package Width	E1	3.90 BSC		
Overall Length	D	9.90 BSC		
Chamfer (Optional)	h	0.25	-	0.50
Foot Length	L	0.40	-	1.27
Footprint	L1	1.04 REF		
Lead Angle	θ	0°	-	-
Foot Angle	φ	0°	-	8°
Lead Thickness	c	0.10	-	0.25
Lead Width	b	0.31	-	0.51
Mold Draft Angle Top	α	5°	-	15°
Mold Draft Angle Bottom	β	5°	-	15°

Notes:

- Pin 1 visual index feature may vary, but must be located within the hatched area.
- § Significant Characteristic
- Dimension D does not include mold flash, protrusions or gate burrs, which shall not exceed 0.15 mm per end. Dimension E1 does not include interlead flash or protrusion, which shall not exceed 0.25 mm per side.
- Dimensioning and tolerancing per ASME Y14.5M
 BSC: Basic Dimension. Theoretically exact value shown without tolerances.
 REF: Reference Dimension, usually without tolerance, for information purposes only.
- Datums A & B to be determined at Datum H.

Microchip Technology Drawing No. C04-108C Sheet 2 of 2

16-Lead Plastic Small Outline (SL) - Narrow, 3.90 mm Body [SOIC]

Note: For the most current package drawings, please see the Microchip Packaging Specification located at <http://www.microchip.com/packaging>

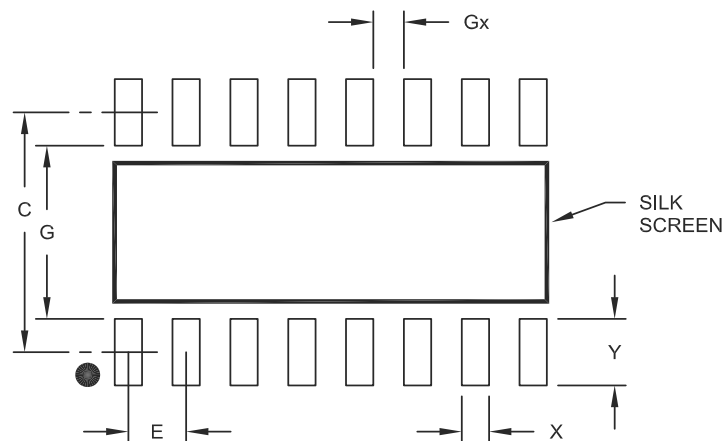

RECOMMENDED LAND PATTERN

Dimension Limits	Units	MILLIMETERS		
		MIN	NOM	MAX
Contact Pitch	E		1.27 BSC	
Contact Pad Spacing	C		5.40	
Contact Pad Width	X			0.60
Contact Pad Length	Y			1.50
Distance Between Pads	Gx	0.67		
Distance Between Pads	G	3.90		

Notes:

1. Dimensioning and tolerancing per ASME Y14.5M

BSC: Basic Dimension. Theoretically exact value shown without tolerances.

Microchip Technology Drawing No. C04-2108A

HV9961

NOTES:

APPENDIX A: REVISION HISTORY

Revision B (March 2022)

- Changed package drawings.
- Updated [Section “Electrical Characteristics”](#).
- Updated [Section “Temperature Specifications”](#).
- Minor format changes throughout.

Revision A (November 2017)

- Converted Supertex Doc# DSFP-HV9961 to Microchip DS20005588A.
- Changed the package marking format.
- Changed the packaging quantity of the LG package from 2500/Reel to 3300/Reel.
- Changed the packaging quantity of the NG M901 media type from 1000/Reel to 2600/Reel.
- Changed the packaging quantity of the NG M934 media type from 2500/Reel to 2600/Reel.
- Made minor text changes throughout the document.

HV9961

PRODUCT IDENTIFICATION SYSTEM

To order or obtain information, e.g., on pricing or delivery, contact your local Microchip representative or sales office.

<u>PART NO.</u>	<u>XX</u>	<u>-X</u>	<u>-X</u>	Examples:	
Device	Package Options	Environmental	Media Type	a) HV9961LG-G:	LED Driver with Average-Current Mode Constant-Current Control, 8-lead SOIC, 3300/Reel
Device:	HV9961	=	LED Driver with Average-Current Mode Constant-Current Control	b) HV9961NG-G:	LED Driver with Average-Current Mode Constant-Current Control, 16-lead SOIC, 45/Tube
Packages:	LG	=	8-lead SOIC	c) HV9961NG-G-M901:	LED Driver with Average-Current Mode Constant-Current Control, 16-lead SOIC, 2600/Reel
	NG	=	16-lead SOIC	d) HV9961NG-G-M934:	LED Driver with Average-Current Mode Constant-Current Control, 16-lead SOIC, 2600/Reel
Environmental:	G	=	Lead (Pb)-free/RoHS-compliant Package	Note 1: Tape and Reel identifier only appears in the catalog part number description. This identifier is used for ordering purposes and is not printed on the device package. Check with your Microchip Sales Office for package availability with the Tape and Reel option.	
Media Types:	(blank)	=	3300/Reel for an LG Package		
	(blank)	=	45/Tube for an NG Package		
	M901	=	2600/Reel for an NG Package		
	M934	=	2600/Reel for an NG Package		
Note:	For Media Types M901 and M934, the base quantity for tape and reel was standardized to 2600/reel. Both options will result in the delivery of the same number of parts/reel.				

Note the following details of the code protection feature on Microchip products:

- Microchip products meet the specifications contained in their particular Microchip Data Sheet.
- Microchip believes that its family of products is secure when used in the intended manner, within operating specifications, and under normal conditions.
- Microchip values and aggressively protects its intellectual property rights. Attempts to breach the code protection features of Microchip product is strictly prohibited and may violate the Digital Millennium Copyright Act.
- Neither Microchip nor any other semiconductor manufacturer can guarantee the security of its code. Code protection does not mean that we are guaranteeing the product is “unbreakable”. Code protection is constantly evolving. Microchip is committed to continuously improving the code protection features of our products.

This publication and the information herein may be used only with Microchip products, including to design, test, and integrate Microchip products with your application. Use of this information in any other manner violates these terms. Information regarding device applications is provided only for your convenience and may be superseded by updates. It is your responsibility to ensure that your application meets with your specifications. Contact your local Microchip sales office for additional support or, obtain additional support at <https://www.microchip.com/en-us/support/design-help/client-support-services>.

THIS INFORMATION IS PROVIDED BY MICROCHIP "AS IS". MICROCHIP MAKES NO REPRESENTATIONS OR WARRANTIES OF ANY KIND WHETHER EXPRESS OR IMPLIED, WRITTEN OR ORAL, STATUTORY OR OTHERWISE, RELATED TO THE INFORMATION INCLUDING BUT NOT LIMITED TO ANY IMPLIED WARRANTIES OF NON-INFRINGEMENT, MERCHANTABILITY, AND FITNESS FOR A PARTICULAR PURPOSE, OR WARRANTIES RELATED TO ITS CONDITION, QUALITY, OR PERFORMANCE.

IN NO EVENT WILL MICROCHIP BE LIABLE FOR ANY INDIRECT, SPECIAL, PUNITIVE, INCIDENTAL, OR CONSEQUENTIAL LOSS, DAMAGE, COST, OR EXPENSE OF ANY KIND WHATSOEVER RELATED TO THE INFORMATION OR ITS USE, HOWEVER CAUSED, EVEN IF MICROCHIP HAS BEEN ADVISED OF THE POSSIBILITY OR THE DAMAGES ARE FORESEEABLE. TO THE FULLEST EXTENT ALLOWED BY LAW, MICROCHIP'S TOTAL LIABILITY ON ALL CLAIMS IN ANY WAY RELATED TO THE INFORMATION OR ITS USE WILL NOT EXCEED THE AMOUNT OF FEES, IF ANY, THAT YOU HAVE PAID DIRECTLY TO MICROCHIP FOR THE INFORMATION.

Use of Microchip devices in life support and/or safety applications is entirely at the buyer's risk, and the buyer agrees to defend, indemnify and hold harmless Microchip from any and all damages, claims, suits, or expenses resulting from such use. No licenses are conveyed, implicitly or otherwise, under any Microchip intellectual property rights unless otherwise stated.

For information regarding Microchip's Quality Management Systems, please visit www.microchip.com/quality.

Trademarks

The Microchip name and logo, the Microchip logo, Adaptec, AnyRate, AVR, AVR logo, AVR Freaks, BesTime, BitCloud, CryptoMemory, CryptoRF, dsPIC, flexPWR, HELDO, IGLOO, JukeBlox, KeeLoq, Kleer, LANCheck, LinkMD, maXStylus, maXTouch, MediaLB, megaAVR, Microsemi, Microsemi logo, MOST, MOST logo, MPLAB, OptoLyzer, PIC, picoPower, PICSTART, PIC32 logo, PolarFire, Prochip Designer, QTouch, SAM-BA, SenGenuity, SpyNIC, SST, SST Logo, SuperFlash, Symmetricom, SyncServer, Tachyon, TimeSource, tinyAVR, UNI/O, Vectron, and XMEGA are registered trademarks of Microchip Technology Incorporated in the U.S.A. and other countries.

AgileSwitch, APT, ClockWorks, The Embedded Control Solutions Company, EtherSynch, Flashtec, Hyper Speed Control, HyperLight Load, IntelliMOS, Libero, motorBench, mTouch, Powermite 3, Precision Edge, ProASIC, ProASIC Plus, ProASIC Plus logo, QuietWire, SmartFusion, SyncWorld, Temux, TimeCesium, TimeHub, TimePictra, TimeProvider, TrueTime, WinPath, and ZL are registered trademarks of Microchip Technology Incorporated in the U.S.A.

Adjacent Key Suppression, AKS, Analog-for-the-Digital Age, Any Capacitor, AnyIn, AnyOut, Augmented Switching, BlueSky, BodyCom, CodeGuard, CryptoAuthentication, CryptoAutomotive, CryptoCompanion, CryptoController, dsPICDEM, dsPICDEM.net, Dynamic Average Matching, DAM, ECAN, Espresso T1S, EtherGREEN, GridTime, IdealBridge, In-Circuit Serial Programming, ICSP, INICnet, Intelligent Paralleling, Inter-Chip Connectivity, JitterBlocker, Knob-on-Display, maxCrypto, maxView, memBrain, Mindi, MiWi, MPASM, MPF, MPLAB Certified logo, MPLIB, MPLINK, MultiTRAK, NetDetach, NVM Express, NVMe, Omniscient Code Generation, PICDEM, PICDEM.net, PICKit, PICtail, PowerSmart, PureSilicon, QMatrix, REAL ICE, Ripple Blocker, RTAX, RTG4, SAM-ICE, Serial Quad I/O, simpleMAP, SimpliPHY, SmartBuffer, SmartHLS, SMART-I.S., storClad, SQL, SuperSwitcher, SuperSwitcher II, Switchtec, SynchroPHY, Total Endurance, TSHARC, USBCheck, VariSense, VectorBlox, VeriPHY, ViewSpan, WiperLock, XpressConnect, and ZENA are trademarks of Microchip Technology Incorporated in the U.S.A. and other countries.

SQTP is a service mark of Microchip Technology Incorporated in the U.S.A.

The Adaptec logo, Frequency on Demand, Silicon Storage Technology, Symmcom, and Trusted Time are registered trademarks of Microchip Technology Inc. in other countries.

GestIC is a registered trademark of Microchip Technology Germany II GmbH & Co. KG, a subsidiary of Microchip Technology Inc., in other countries.

All other trademarks mentioned herein are property of their respective companies.

© 2017-2022, Microchip Technology Incorporated and its subsidiaries.

All Rights Reserved.

ISBN: 978-1-6683-0082-4



MICROCHIP

Worldwide Sales and Service

AMERICAS

Corporate Office
2355 West Chandler Blvd.
Chandler, AZ 85224-6199
Tel: 480-792-7200
Fax: 480-792-7277
Technical Support:
<http://www.microchip.com/support>
Web Address:
www.microchip.com

Atlanta

Duluth, GA
Tel: 678-957-9614
Fax: 678-957-1455

Austin, TX

Tel: 512-257-3370

Boston

Westborough, MA
Tel: 774-760-0087
Fax: 774-760-0088

Chicago

Itasca, IL
Tel: 630-285-0071
Fax: 630-285-0075

Dallas

Addison, TX
Tel: 972-818-7423
Fax: 972-818-2924

Detroit

Novi, MI
Tel: 248-848-4000

Houston, TX

Tel: 281-894-5983

Indianapolis

Noblesville, IN
Tel: 317-773-8323
Fax: 317-773-5453
Tel: 317-536-2380

Los Angeles

Mission Viejo, CA
Tel: 949-462-9523
Fax: 949-462-9608
Tel: 951-273-7800

Raleigh, NC

Tel: 919-844-7510

New York, NY

Tel: 631-435-6000

San Jose, CA

Tel: 408-735-9110
Tel: 408-436-4270

Canada - Toronto

Tel: 905-695-1980
Fax: 905-695-2078

ASIA/PACIFIC

Australia - Sydney
Tel: 61-2-9868-6733

China - Beijing
Tel: 86-10-8569-7000

China - Chengdu
Tel: 86-28-8665-5511

China - Chongqing
Tel: 86-23-8980-9588

China - Dongguan
Tel: 86-769-8702-9880

China - Guangzhou
Tel: 86-20-8755-8029

China - Hangzhou
Tel: 86-571-8792-8115

China - Hong Kong SAR
Tel: 852-2943-5100

China - Nanjing
Tel: 86-25-8473-2460

China - Qingdao
Tel: 86-532-8502-7355

China - Shanghai
Tel: 86-21-3326-8000

China - Shenyang
Tel: 86-24-2334-2829

China - Shenzhen
Tel: 86-755-8864-2200

China - Suzhou
Tel: 86-186-6233-1526

China - Wuhan
Tel: 86-27-5980-5300

China - Xian
Tel: 86-29-8833-7252

China - Xiamen
Tel: 86-592-2388138

China - Zhuhai
Tel: 86-756-3210040

ASIA/PACIFIC

India - Bangalore
Tel: 91-80-3090-4444

India - New Delhi
Tel: 91-11-4160-8631

India - Pune
Tel: 91-20-4121-0141

Japan - Osaka
Tel: 81-6-6152-7160

Japan - Tokyo
Tel: 81-3-6880-3770

Korea - Daegu
Tel: 82-53-744-4301

Korea - Seoul
Tel: 82-2-554-7200

Malaysia - Kuala Lumpur
Tel: 60-3-7651-7906

Malaysia - Penang
Tel: 60-4-227-8870

Philippines - Manila
Tel: 63-2-634-9065

Singapore
Tel: 65-6334-8870

Taiwan - Hsin Chu
Tel: 886-3-577-8366

Taiwan - Kaohsiung
Tel: 886-7-213-7830

Taiwan - Taipei
Tel: 886-2-2508-8600

Thailand - Bangkok
Tel: 66-2-694-1351

Vietnam - Ho Chi Minh
Tel: 84-28-5448-2100

EUROPE

Austria - Wels
Tel: 43-7242-2244-39
Fax: 43-7242-2244-393

Denmark - Copenhagen
Tel: 45-4485-5910
Fax: 45-4485-2829

Finland - Espoo
Tel: 358-9-4520-820

France - Paris
Tel: 33-1-69-53-63-20
Fax: 33-1-69-30-90-79

Germany - Garching
Tel: 49-8931-9700

Germany - Haan
Tel: 49-2129-3766400

Germany - Heilbronn
Tel: 49-7131-72400

Germany - Karlsruhe
Tel: 49-721-625370

Germany - Munich
Tel: 49-89-627-144-0
Fax: 49-89-627-144-44

Germany - Rosenheim
Tel: 49-8031-354-560

Israel - Ra'anana
Tel: 972-9-744-7705

Italy - Milan
Tel: 39-0331-742611
Fax: 39-0331-466781

Italy - Padova
Tel: 39-049-7625286

Netherlands - Drunen
Tel: 31-416-690399
Fax: 31-416-690340

Norway - Trondheim
Tel: 47-7288-4388

Poland - Warsaw
Tel: 48-22-3325737

Romania - Bucharest
Tel: 40-21-407-87-50

Spain - Madrid
Tel: 34-91-708-08-90
Fax: 34-91-708-08-91

Sweden - Gothenberg
Tel: 46-31-704-60-40

Sweden - Stockholm
Tel: 46-8-5090-4654

UK - Wokingham
Tel: 44-118-921-5800
Fax: 44-118-921-5820