

GNSS Receiver Module A5135-H

User Guide

Part Number PMD-00034
Revision C May 2021

Intellectual Property

© 2019-2020 Lantronix, Inc. All rights reserved. No part of the contents of this publication may be transmitted or reproduced in any form or by any means without the written permission of Lantronix.

Lantronix is a registered trademark of Lantronix, Inc. in the United States and other countries.

Patented: www.lantronix.com/legal/patents/. Additional patents pending.

Windows and *Internet Explorer* are registered trademarks of Microsoft Corporation. *Firefox* is a registered trademark of the Mozilla Foundation. *Chrome* is a trademark of Google Inc. All other trademarks and trade names are the property of their respective holders.

Warranty

For details on the Lantronix warranty policy, please go to our web site at www.lantronix.com/support/warranty/

Contacts

Lantronix, Inc.

7535 Irvine Center Drive, Suite 100
Irvine, CA 92618, USA
Toll Free: 800-526-8766
Phone: 949-453-3990
Fax: 949-453-3995

Technical Support

Online: www.lantronix.com/support

Sales Offices

For a current list of our domestic and international sales offices, go to the Lantronix web site at www.lantronix.com/about-us/contact/

Disclaimer

All information contained herein is provided "AS IS." Lantronix undertakes no obligation to update the information in this publication. Lantronix does not make, and specifically disclaims, all warranties of any kind (express, implied or otherwise) regarding title, non-infringement, fitness, quality, accuracy, completeness, usefulness, suitability or performance of the information provided herein. Lantronix shall have no liability whatsoever to any user for any damages, losses and causes of action (whether in contract or in tort or otherwise) in connection with the user's access or usage of any of the information or content contained herein. The information and specifications contained in this document are subject to change without notice.

Open Source Software

Some applications are Open Source software licensed under the Berkeley Software Distribution (BSD) license, the GNU General Public License (GPL) as published by the Free Software Foundation (FSF), or the Python Software Foundation (PSF) License Agreement for Python 2.7.3 (Python License). Lantronix grants you no right to receive source code to the Open Source software; however, in some cases, rights and access to source code for certain Open Source software may be available directly from Lantronix' licensors. Your use of each Open Source component or software is subject to the terms of the applicable license. The BSD license is available at <http://opensource.org/licenses>. The GNU General Public License is available at <http://www.gnu.org/licenses/>. The Python License is available at <http://cmpt165.csil.sfu.ca/Python-Docs/license.html>. Your use of each Open Source component or software is subject to the terms of the applicable license.

OPEN SOURCE SOFTWARE IS DISTRIBUTED WITHOUT ANY WARRANTY, INCLUDING ANY IMPLIED WARRANTY OF MERCHANTABILITY OR FITNESS FOR A PARTICULAR PURPOSE. SEE THE APPLICABLE LICENSE AGREEMENT FOR ADDITIONAL INFORMATION.

You may request a list of the open source components and the licenses that apply to them. Contact your regional Lantronix sales associate. www.lantronix.com/about-us/contact/

Revision History

Date	Rev.	Comments
April 2014	0.1	First release
January 2015	0.2	Pin assignment updated
February 2015	0.3	Updated figures
February 2017	0.4	Update the description about the ON_OFF pin
May 2017	0.5	<ul style="list-style-type: none">• Updated some sentence for easier understanding• Fixed pin7/8 in the pin descriptions• Added picture for label• Edited picture to 3.3V
November 2019	A	Added Lantronix document part number, Lantronix logo, branding, contact information, and links.
May 2020	B	<ul style="list-style-type: none">• Updated Table 4 pin descriptions for pins 7, 8, 16.• Updated schematics (Figure 5 and 7), pins 17 and 18 to NC.
May 2021	C	<ul style="list-style-type: none">• Updated label description (section 1.4).

For the latest revision of this product document, please check our online documentation at www.lantronix.com/support/documentation.

Table of Contents

Intellectual Property _____	2
Warranty _____	2
Contacts _____	2
Disclaimer _____	2
Open Source Software _____	3
Revision History _____	3
Table of Contents _____	4
List of Figures _____	6
List of Tables _____	7
1 Introduction _____	8
1.1 Feature Overview _____	8
1.2 Characteristics Overview _____	9
1.3 RoHS and Lead-Free Information _____	9
1.4 Label _____	10
1.5 Characteristics _____	11
1.5.1 GNSS Characteristics _____	11
1.5.2 Mechanical Characteristics _____	11
1.6 Handling Precautions _____	11
2 Ordering Information _____	12
2.1 GNSS Receiver A5135-H _____	12
2.2 Packing _____	12
2.3 Additional Equipment _____	14
3 Quick Start _____	15
3.1 Minimum Configuration _____	15
3.2 Antenna _____	17
3.3 Serial Port Settings _____	17
3.4 Improved TTFF _____	17
3.5 Self-start configuration _____	17
4 Mechanical Outline _____	18
4.1 Detailed Component Side A5135-H _____	18
4.2 Detailed Solder Side A5135-H _____	19
5 Pin-out Information _____	20
5.1 Layout A5135-H _____	20
5.2 Description A5135-H Signals _____	21
6 Electrical Characteristics _____	22
6.1 Operating Conditions _____	22
6.2 Absolute Maximum Ratings _____	22

6.3 DC Electrical Characteristics	23
7 Mounting	24
7.1 Proposed Footprint for Soldering	24
7.2 PCB Design Guide	24
7.3 Recommended Profile for Reflow Soldering	25
8 Use of External Antenna	26
8.1 Connection of RF Signal	26
8.2 External Antenna	27
8.2.1 Recommended Parameters	27
8.2.2 Hints	27
9 Quality and Reliability	28
9.1 Environmental Conditions	28
9.2 Product Qualification	28
9.3 Production Test	28
10 Applications and Hints	29
10.1 Initial Module Start	29
10.2 Proper Shutdown	29
10.3 SiRFaware™ Support	29
10.4 Push-to-Fix Mode	29
10.5 Hibernate Mode	29
10.6 Extended Ephemeris	30
10.7 TM_GPIO5 pin (1 pulse per second pin)	30
10.8 5 Hz Navigation Update Rate	31
11 Evaluation Kit EVA5135-H	32
12 Related Information	33
12.1 Related Documents	33
12.2 Related Tools	33

List of Figures

Figure 1: A5135-H label	10
Figure 2: A5135-H tape specifications (1)	12
Figure 3: A5135-H tape specifications (2)	13
Figure 4: A5135-H tape specifications (3)	13
Figure 5: Minimum configuration A5135-H	15
Figure 6: RS232 level shifter for minimum configurations	16
Figure 7: Self-start configuration A5135-H	17
Figure 8: Mechanical outline component side A5135-H	18
Figure 9: Mechanical outline solder side A5135-H	19
Figure 10: Pin-out information (top view) A5135-H	20
Figure 11: Proposal of Soldering footprint	24
Figure 12: Proposal (1) of the PCB design	24
Figure 13: Proposal (2) of the PCB design	25
Figure 14: Antenna connector strip line A5135-H	26
Figure 15: Strip line parameters A5135-H	26
Figure 16: 1PPS waveform (reference)	31
Figure 17: Evaluation kit EVA5135-H	32

List of Tables

Table 1: A5135-H GNSS characteristics	11
Table 2: A5135-H dimensions and weight.....	11
Table 3: Additional equipment.....	14
Table 4: Pin description A5135-H.....	21
Table 5: A5135-H electrical characteristics	22
Table 6: Absolute maximum ratings	22
Table 7: DC electrical characteristics	23
Table 8: Reflow soldering profile A5135-H	25
Table 9: Environmental conditions	28

1 Introduction

A5135-H is an antenna module with SiRFstarV™ Flash based chip and an on-board patch antenna (15mm x 15mm x 4mm). It is a new version of our existing A2035-H & A2235-H with new GNSS support. To support an easier migration for existing customers, we kept the same pin assignment.

Please take care that since there is a RF feed point underneath the module, special PCB design is required on user's application.

The A5135-H is a module designed for a 3.3V environment.

1.1 Feature Overview

The A5135-H is a new module with the following outstanding features.

- Fast, responsive location experience
 - High-sensitive navigation engine with tracking down to -165dBm
 - 52 track verification channels
 - SBAS (WAAS, EGNOS, MSAS, GAGAN)
 - Concurrent tracking of multiple constellations of the GPS and GLONASS systems
- Breakthrough micro power technology
 - Requires only 50 – 500μA to maintain hot start capability
- Active jammer remover
 - Removes in-band jammers up to 80dB/Hz
 - Tracks up to eight CW (continuous wave) jammers
- Size: 17.8mm (L) x 16.5mm (W) x 7.1mm (H)
- Operating voltage: 3V3
- Extremely low power consumption by using DC/DC converter
- No back-up battery required
- TCXO is used for providing stable 26MHz system clock
- Support external active antenna
- Support SGEE and CGEE
- Build-in LNA with close to 20dB for the patch antenna

1.2 Characteristics Overview

The module's most important characteristics are:

- A5135-H
 - Operable at 3.3V / 34mA @ 1fix per second
 - UART interface at CMOS level
 - V_BAK at 3.0V / 60uA (typ.)
- Internal Power-On-Reset (POR) reset chipset to prevent memory corruption if main power removal abruptly
- Internal 4 Mb SPI Flash
- Small form factor of 17.78 x 16.51 mm² (0.7" x 0.65")
- Supported temperature range: -40°C to +85°C
- Single-sided SMT component, for reflow soldering
- RoHS compliant, lead-free
- Tape & reel packaging
- Excellent antenna support
 - On-module patch antenna
 - Antenna input for direct connection of external active antenna
 - RF switch to select between antennas

The antenna receiver module is available as an off-the-shelf component, 100% tested and shipped in tape-and-reel packaging.

1.3 RoHS and Lead-Free Information

Lantronix's products marked with the lead-free symbol either on the module or the packaging comply with the "Directive 2002/95/EC of the European Parliament and the Council on the Restriction of Use of certain Hazardous Substances in Electrical and Electronic Equipment" (RoHS).



All Lantronix GNSS receiver modules, GNSS antenna receiver module and telematics units are RoHS compliant.

1.4 Label

The A5135-H label (size: 12.0x 4.0 mm²) contains the following information:



Figure 1: A5135-H label

The label is placed on the side of the GNSS antenna. The data matrix code holds the product number, software part number, software release, hardware release, factory code, year & week of assembly and a 6-digit serial number. Due to limited space on module label, only product type, year & week of assembly and 6-digit serial number will be printed on it.

Representing	Factory location	Product Number	S/W Part Number	Software Release	Hardware Release	Assembly Year/Week	Serial Number
Number of digits (26)	XX	XXXXXX	XXXX	XX	XX	XXXX	XXXXXX
	2	6	4	2	2	4	6
Example	TF	A5135H	9333	01	01	1211	000005
Meaning	TF	Given	Given	Given	Given	Year=12 Week=11	Increment from 000001 up to 999999

Example of MID#: TFA5135H933301011211000005

1.5 Characteristics

The module is characterized by the following parameters.

1.5.1 GNSS Characteristics

Channels		52, parallel tracking
Correlators		~400,000
Frequency	GPS	L1 (= 1,575 MHz)
	GLONASS	FDMA L1 (=1,602 MHz)
Tracking Sensitivity On-module antenna	GPS+GLONASS	-165 dBm
Horizontal Position Accuracy	Stand alone	< 2.5 m CEP (SA off)
Time To First Fix – TFFF (theoretical minimum values; values in real world may differ)	Obscuration recovery (1)	0.1 s
	Hot start (2)	< 1 s
	Warm (3)	< 30 s
	Cold (4)	< 35 s

Table 1: A5135-H GNSS characteristics

- (1) The calibrated clock of the receiver has not stopped; thus it knows precise time (to the μ s level).
- (2) The receiver has estimates of time/date/position and valid almanac and ephemeris data.
- (3) The receiver has estimates of time/date/position and recent almanac.
- (4) The receiver has no estimate of time/date/position, and no recent almanac.

Note: Performance (sensitivity and TFFF) might slightly decrease below -30°C .

1.5.2 Mechanical Characteristics

A5135-H Mechanical dimensions	Length	17.78 \pm 0.20 mm, 0.7 \pm 0.008"
	Width	16.51 \pm 0.20 mm, 0.65 \pm 0.008"
	Height	7.11 mm, 0.28" (Max)
A5135-H Weight		4.0 g, 0.14 oz

Table 2: A5135-H dimensions and weight

1.6 Handling Precautions

The GNSS receiver module A5135-H is sensitive to electrostatic discharge (ESD). Please handle with appropriate care.

2 Ordering Information

2.1 GNSS Receiver A5135-H

The order number is built as follows: **A5135-Hxxxx**

A5135-H is the model name. The “xxxx” refers to the current part number on the module.

2.2 Packing

The A5135-H GNSS modules come in a tape and reel package suitable for pick and place machines.

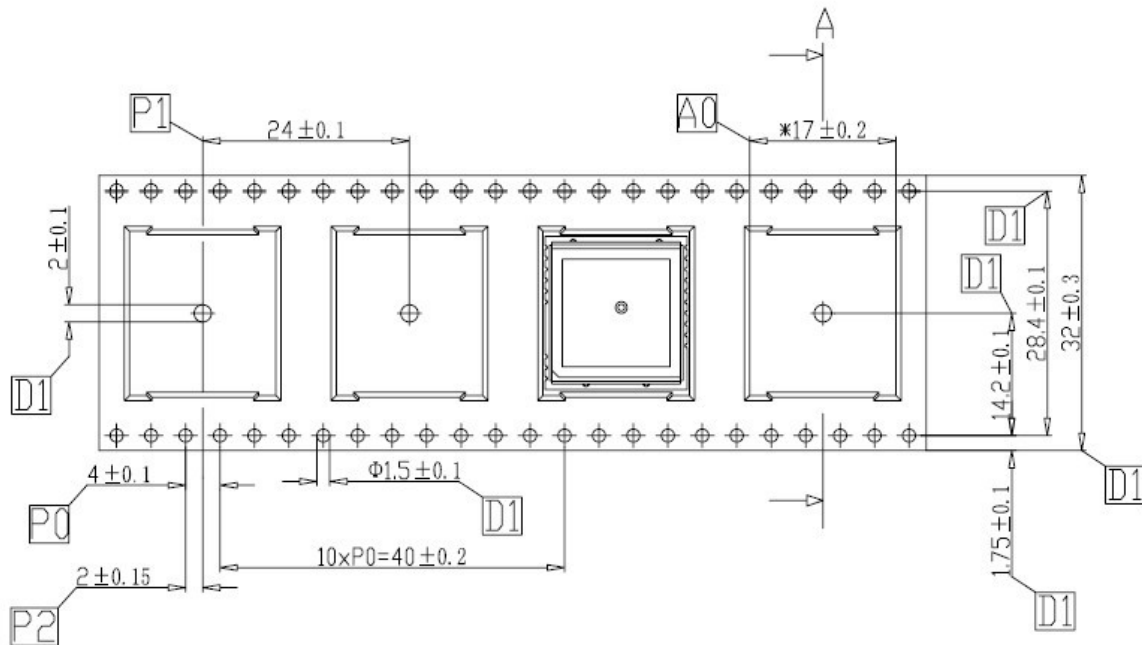

Figure 2: A5135-H tape specifications (1)

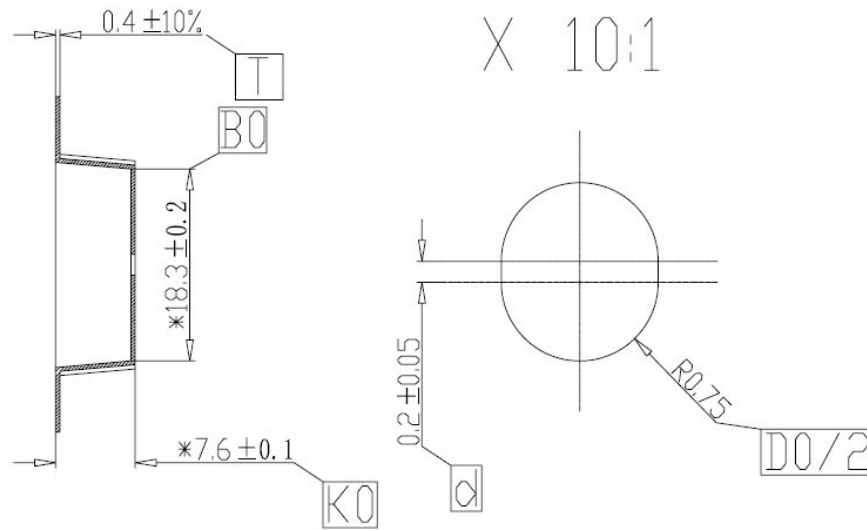

Figure 3: A5135-H tape specifications (2)

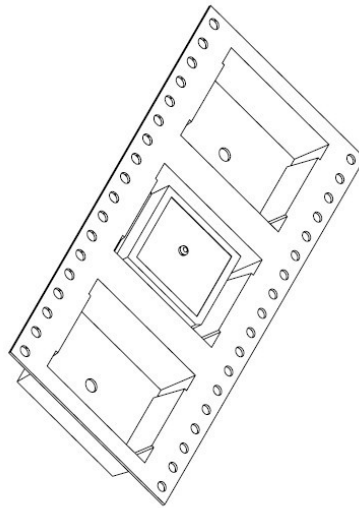

Figure 4: A5135-H tape specifications (3)

One complete reel holds 500 A5135-H modules.

Packaging for shipment:

One box holds 1 reel
 Reel diameter: 38 cm
 Outer Box dimensions: 38.8 (W) x 38.8 (L) x 5.7 (H) cm
 Gross weight: 5.06 Kg
 Net weight: 4.13 Kg

2.3 Additional Equipment

EVA5135-H	Evaluation Kit (including one module A5135-H)
-----------	---

Table 3: Additional equipment

A detailed description of the EVA5135-H Evaluation Kit can be found in the appropriate manual.

3 Quick Start

To allow an easy and quick start with the A5135-H module, this chapter provides a short overview on the important steps to be taken to receive NMEA messages with position information on a serial port (UART).

NOTE 1: The A5135-H needs an external pull-up resistor to be configured for UART operation. Please consider the pull-up resistor in your design or pull the GPIO up right after reset by other means.

NOTE 2: The ON_OFF pin of the A5135-H needs to be connected to high level to power on.

NOTE 3: To let existing A2235-H customers to drop-in replace original design with A5135-H, they must send an NMEA command to switch the protocol and baud rate to NMEA 4,800. Command: \$PSRF100,1,4800,8,1,0*0E

3.1 Minimum Configuration

The following picture shows the minimum configuration for NMEA or binary outputs received and commands sent via an RS232 interface based on the GNSS module A5135-H.

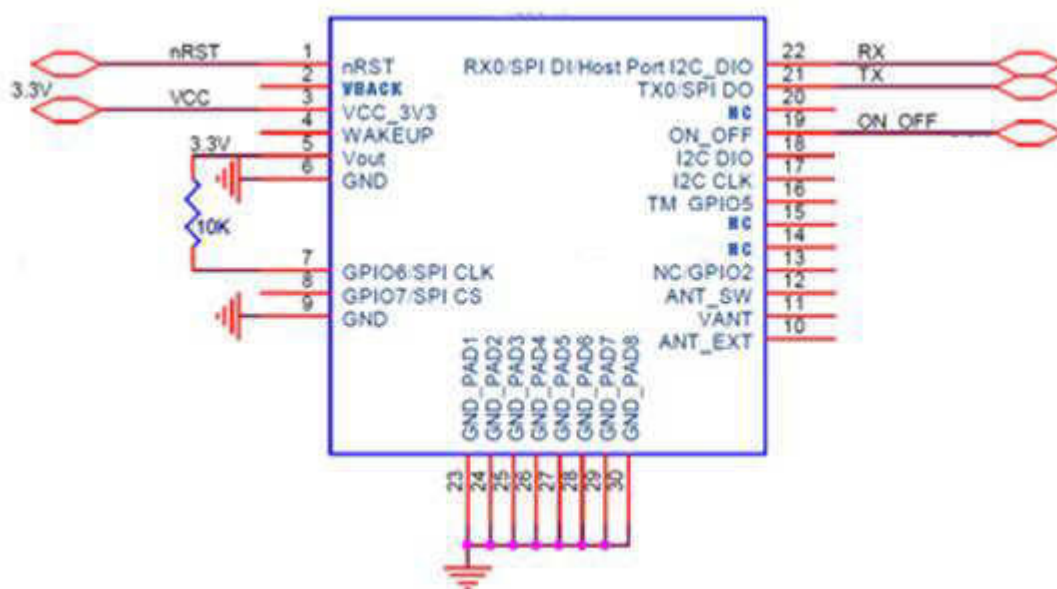

Figure 5: Minimum configuration A5135-H

NOTE: It is recommended to supply Vcc continuously! Use SiRFaware™ or other low power modes to reduce power consumption of the module while no position information is required.

- External antenna input impedance is 50 Ω. Match as close as possible.
- Maximum allowed external antenna current is 50 mA. Consider a current limiter.

For completeness the following picture shows the use of an RS232 level shifter.

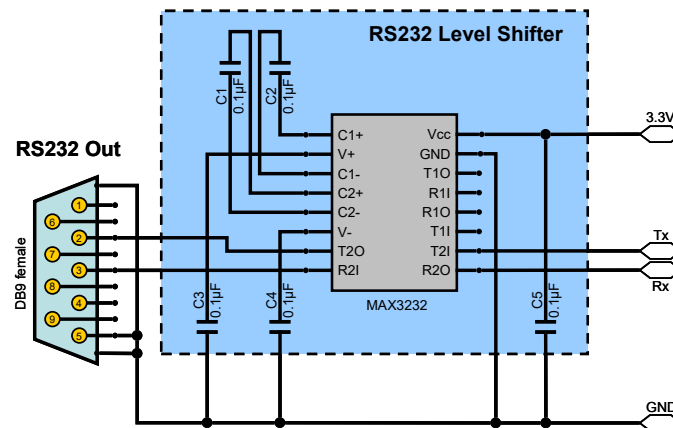

Figure 6: RS232 level shifter for minimum configurations

Remarks:

- Place C1 to C5 (here: 0.1 μ F) close to MAX3232. For capacity values see datasheet of actual component used.
- Use 3.3V level shifter (MAX3232 or equivalent).

3.2 Antenna

Although the A5135-H offers an on-module antenna, an additional external active antenna can be used. Switching between both antennas is done via pin 12 (see also “5.2 Description A5135-H Signals”).

It is recommended to use an active GPS+GLONASS antenna with supply voltage of 3 to 5 VDC and a current draw of 50 mA maximum. The quality of the GPS+GLONASS antenna chosen is of great importance to the overall sensitivity of the GPS+GLONASS system. An active antenna should have a gain ≥ 20 dB and a noise figure ≤ 1.5 dB, which applies to more than 95% of the active antennas available in the market.

3.3 Serial Port Settings

In UART operation (defined by the external pull-up resistor as outlined in Minimum Configuration) the default serial port settings are:

- NMEA, 9600 baudrate, 8 data bits, no parity, 1 stop bit, no flow control

3.4 Improved TTFF

In order to improve the TTFF (Time To First Fix), it is recommended to keep Vcc supplied at all times. This will allow taking advantage of sophisticated low power mode features of the SiRFstarV ROM chip set.

3.5 Self-start configuration

In order to minimize the GPIO required for operating A5135-H, WAKEUP (pin 4) and ON_OFF (pin 19) can be tied together for entering the self-start mode such that no ON_OFF pulse requires. Figure 7 shows the recommended connection for self-start configuration with UART host port enabled.

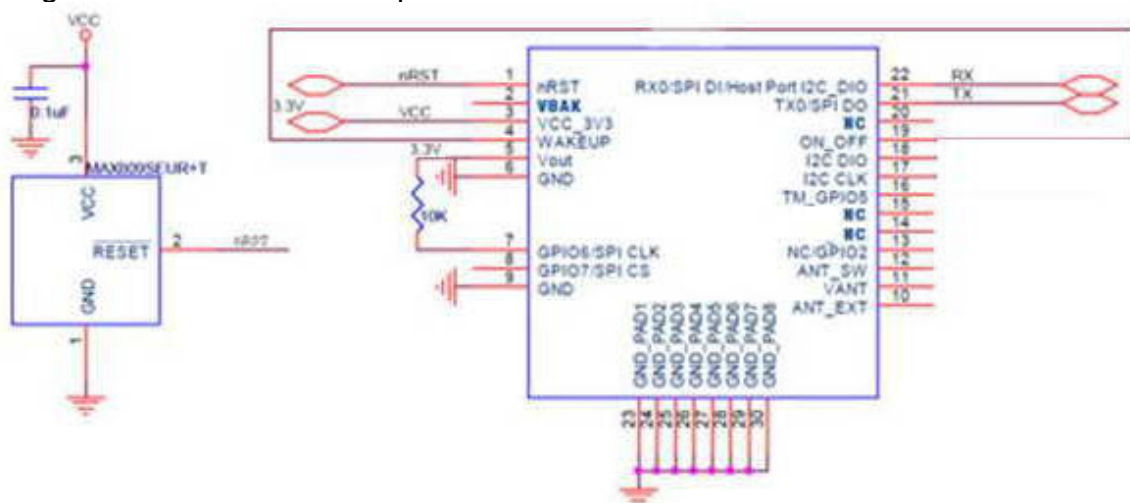
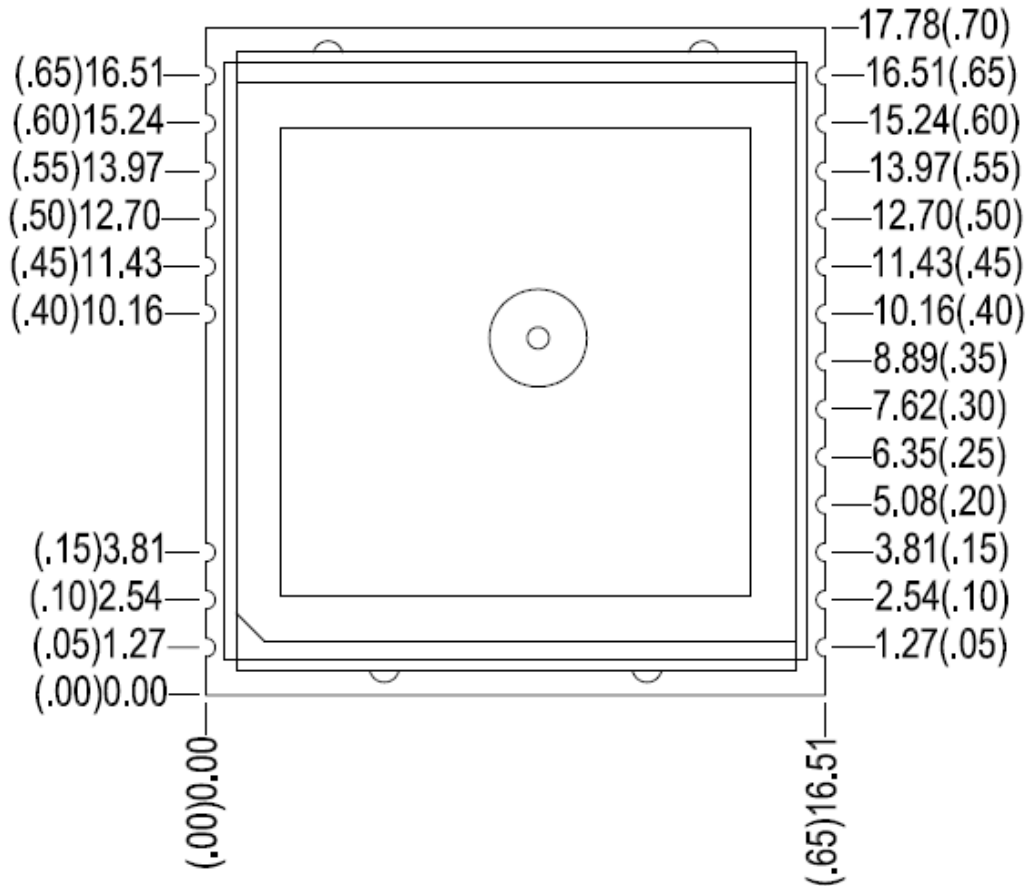

Figure 7: Self-start configuration A5135-H

For self-start mode, full power operation will be activated once Vcc applied. No power saving mode (PTF/MPM/Hibernation) will be supported.

4 Mechanical Outline

4.1 Detailed Component Side A5135-H



All dimensions in [mm] / [(inches)]

Figure 8: Mechanical outline component side A5135-H

5 Pin-out Information

5.1 Layout A5135-H

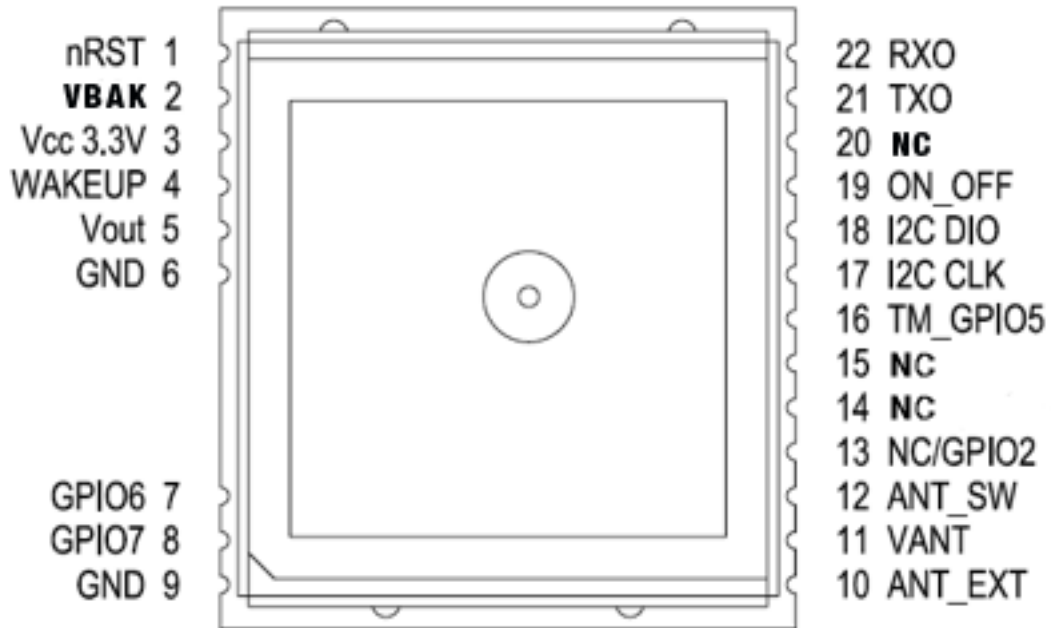

Figure 10: Pin-out information (top view) A5135-H

5.2 Description A5135-H Signals

Pin	Symbol	Function	Description
1	nRST	Input	Reset input, active low
2	V_BAK	Power Supply	Back - up pin of module for "super cap" or battery
3	VCC3V3	Power Supply	3.0 – 3.6 V DC
4	WAKEUP	Output	- Status of digital section, Push-Pull output Low = OFF, KA (Keep Alive)-only, Hibernate, or Standby mode High = ON, operational mode - Connect it to ON_OFF pin for self-start mode
5	Vout	Voltage Output	Permanent 3.3V voltage output for up to 20mA current max.
6	GND	Power Supply	Ground (power supply)
7	GPIO6 CTS (SPI CLK)	Input	Configuration pin for communication mode. <ul style="list-style-type: none"> • Pull-up 10k to 3.3V for UART mode • Leave open for I2C mode • Leave open for SPI mode
8	GPIO7 RTS (SPI CS)	Input	Configuration pin for communication mode. <ul style="list-style-type: none"> • Leave open for UART mode • Pull-down for I2C mode • Leave open for SPI mode
9	GND	Power Supply	Ground (power supply)
10	ANT_EXT	Antenna Input	Antenna signal / Z=50 Ohm (external active antenna input)
11	VANT	Power supply	Power supply antenna – provide according voltage (up to 5.0 VDC) - VANT feeds Pin 10 ANT_EXT
12	ANT_SW	Input	Antenna switch (LOW or open = internal antenna, HIGH = external antenna)
13	GPIO2	None	Leave open
14	NC	None	Leave open
15	NC	None	Leave open
16	TM_GPIO5	Output	Time Mark (1PPS signal) on the A5135-H is NOT for timing applications.
17	NC	None	Leave open
18	NC	None	Leave open
19	ON_OFF	Input	Power control input. High-level input initiates system transitions from OFF to ON, Low-level input initiates an orderly transition to the OFF state
20	NC	None	Leave Open
21	TX / (SPI DO)	Output	Serial data output. -NMEA output if configured for UART -SPI data out pin when module works in SPI mode.
22	RX / (SPI DI) / (Host Port I2C_DIO)	Input	Serial data input. -NMEA input if configured for UART -SPI data input pin when module works in SPI mode; -Host port I2C data I/O pin when module works in hist port I2C mode.

Table 4: Pin description A5135-H

6 Electrical Characteristics

6.1 Operating Conditions

Pin	Description	Min	Typical	Max
3	Vcc	3.0 V	3.3 V	3.6 V
	Full power mode (Searching) Peak Current (1)		42 mA	
	Full power mode (Searching) Average Current (2)		36 mA	
	Full power mode (Tracking) Average Current (3)		22 mA	
	TricklePower™ Mode		7.2 mA	
	Push-to-Fix Mode		0.9 mA	
	Micro Power Mode (SiRFaware™)		29 µA	
	Hibernate Status		27 µA	

Table 5: A5135-H electrical characteristics

- (1) Peak searching current is characterized by millisecond bursts above average searching current
- (2) Average searching current is typically only the first two seconds of TTFF
- (3) Tracking current typically includes tracking and the post searching portion of TTFF

6.2 Absolute Maximum Ratings

Symbol	Parameter	Min	Max	Unit
Vcc	Power supply	-0.3	+4.6	V
Vin	Voltage to I/O pin	-0.3	+3.6	V
Iov	Input current on any pin	-10	10	mA
Itdv	Absolute sum of all input currents during overload condition		200	mA
Tst	Storage temperature	-40	85	°C

Table 6: Absolute maximum ratings

Stresses beyond those listed under “Absolute Maximum Ratings” may cause permanent damage to the device. This is a stress rating only. Functional operation of the device at these or any other conditions beyond those indicated in the operational sections of this specification is not implied. Exposure to absolute maximum rating conditions for extended periods may affect device reliability.

6.3 DC Electrical Characteristics

Symbol	Parameter	Min	Max	Unit
TX0, WAKEUP	Voh @ 4mA	0.75Vcc	Vcc	V
	Vol @ 4mA		0.40	V
RX0	Vih	0.7Vcc	Vcc	V
	Vil		0.40	V
nRST	For safe reset		0.2	V
ON_OFF	Vih	0.7Vcc	Vcc	V
	Vil	-0.3	0.40	V

Table 7: DC electrical characteristics

7 Mounting

This chapter describes the suggested mounting process for the A5135-H GNSS receiver modules. In a RoHS, compliant product with a RoHS compliant process it is recommended to use chemical tin as the counter-part to the module's pins. This will guarantee highest resistance against shocks.

7.1 Proposed Footprint for Soldering

The following proposal of a footprint for soldering is assuming a stencil thickness of 150 μ m. ✕ marks the center of the through holes.

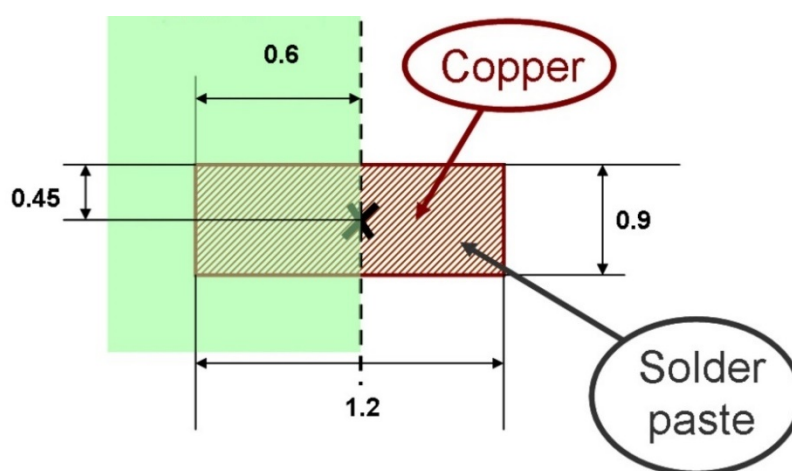

Figure 11: Proposal of Soldering footprint

Please note that copper and solder paste footprints are identical. The final footprint should be evaluated and qualified by the manufacturer according to the specific process.

7.2 PCB Design Guide

1. Drill a through hole with diameter greater than or equal to 3mm in the application PCB which is underneath the RF feed-point to alleviate the interference from RF signal to other part of circuitries. Besides, ground vias (says, 8) should be placed surrounding the through hole for further shielding purpose.

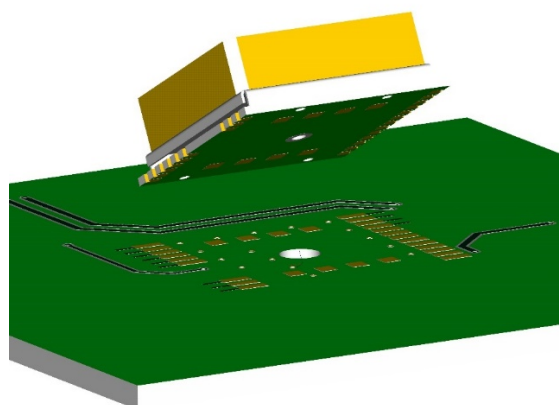

Figure 12: Proposal (1) of the PCB design

2. If proposal 1 is not allowed. Placed a round Copper keep out region (diameter $\geq 3\text{mm}$) on the application PCB underneath the RF feed-point to alleviate the interference from RF signal to other part of circuitries. Besides, ground vias (says, 8) should be placed surrounding the through hole for further shielding purpose.

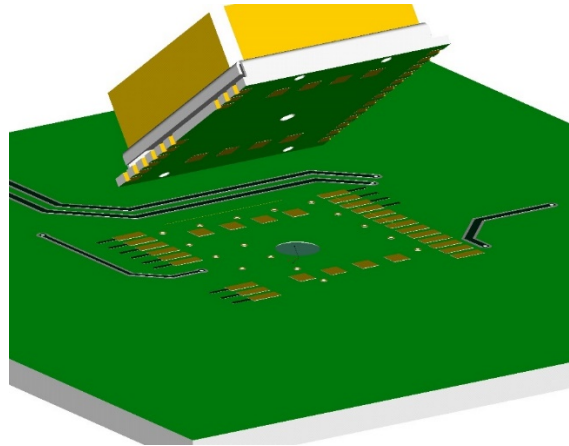

Figure 13: Proposal (2) of the PCB design

7.3 Recommended Profile for Reflow Soldering

Typical values for reflow soldering of the module in convection or IR/convection ovens are as follows (according to IPC/JEDEC J-STD-020D):

Parameter	Value
Peak temperature (RoHS compliant process)	245°C
Average ramp up rate to peak (217°C to Peak)	3°C / second max.
Preheat temperature	min=150°C; max=200°C
Ramp up time from min. to max. preheat temperature	60 ... 120 seconds
Temperature maintained above 217°C	60 ... 150 seconds
Time within 5°C of actual peak temperature	30 seconds
Ramp down rate	6°C / second max.
Time 25°C to peak temperature	8 minutes max.

Table 8: Reflow soldering profile A5135-H

As results of soldering may vary among different soldering systems and types of solder and depend on additional factors like density and types of components on board, the values above should be considered as a starting point for further optimization.

8 Use of External Antenna

8.1 Connection of RF Signal

The ANT_EXT pin is used to connect the receiver with the GNSS antenna. The design of the antenna connection must be strictly done according to RF design rules. Following drawings explain the guidelines:

- the main rule is to keep the strip line as short as possible.
- 50 Ω PCB strip line is required.
- the strip line needs a good reference ground.

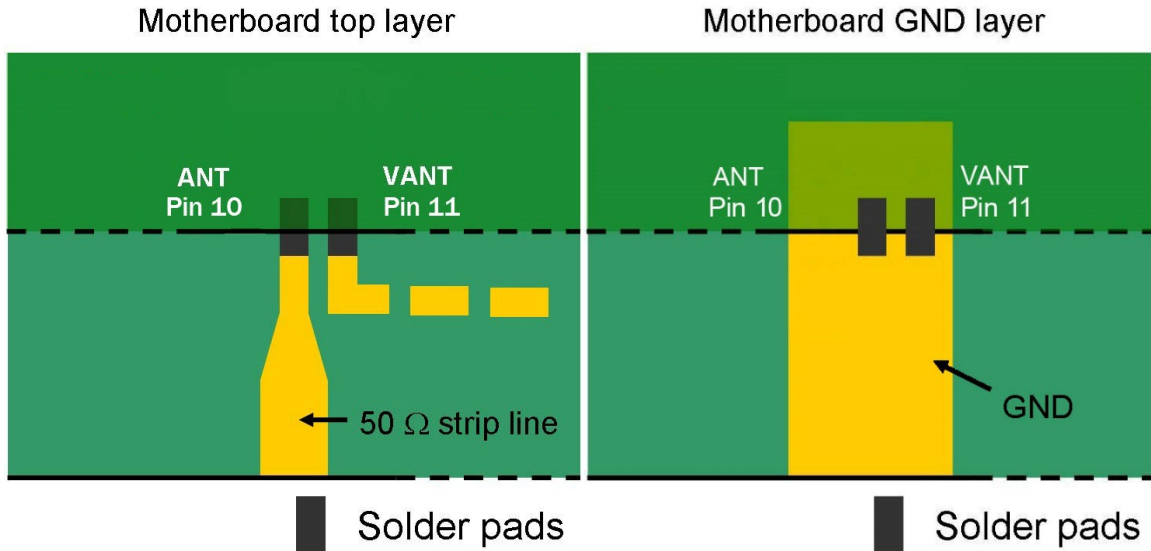

Figure 14: Antenna connector strip line A5135-H

To achieve the impedance of 50 Ω , the width of the strip line needs to be calculated. It depends on the thickness or height of the PCB layer (both parameters are shown in following drawing). For the calculation, it is assumed that the PCB material is FR4.

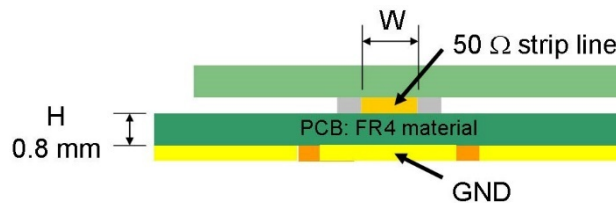

Figure 15: Strip line parameters A5135-H

In this case, the width should be about 1.8 times the height of the PCB:

$$W = 1.8 \times H$$

In the example, you would get a width of $W = 1.8 \times 0.8 \text{ mm} = 1.44 \text{ mm}$.

8.2 External Antenna

8.2.1 Recommended Parameters

General GPS+GLONASS active antenna specification:

Limitations:

- Supply voltage according to voltage fed into VANT pin (5 V max.)
- Supply current 50 mA (max.)

Recommendations:

- Gain ≥ 20 dB (should not exceed 35 dB)
- Noise figure ≤ 1.5 dB

The recommendations apply to most active antennas that can be found in the market. The quality and suitability of the GPS+GLONASS antenna chosen is great importance to the overall sensitivity of the GPS+GLONASS system.

The system design needs to reflect the supply voltage of the antenna. If the supply voltage is equal to V_{cc} , then it could be connected to VANT. If the antenna requires a different supply voltage, the antenna bias can be provided through the VANT pin.

8.2.2 Hints

Unused antenna inputs should be terminated with $50 \Omega \pm 20\%$. Do not feed the antenna supply voltage into terminated antenna inputs.

9 Quality and Reliability

9.1 Environmental Conditions

Operating temperature	-40°C ... +85°C
Operating humidity	Max. 85% r. H., non-condensing, at 85°C
MSL JEDEC (Moisture Sensitivity Level)	3
Storage	6 months in original package

Table 9: Environmental conditions

9.2 Product Qualification

Prior to product qualification the GPS+GLONASS receiver is preconditioned according to EIA/JEDEC standard JESD22-A113-B / Level 3.

Basic qualification tests:

- MSL Classification according to J-STD-020C (MSL3 @ 245°C)
(Refer to report: SZRL2011110048)
- MSL Rework Compatibility according to J-STD-020C
(Refer to report: SZRL2011110048)
- Temperature Cycling –40°C ... +85°C
- Temperature Humidity Bias 70°C / 85% RH
- Low / High Temperature Operating –40°C / +85°C
- High Temperature Operating Life +85°C
- Vibration Variable Frequency
- Mechanical Shock

Please contact Lantronix for detailed information.

9.3 Production Test

Each module is electrically tested prior to packing and shipping to ensure state of the art GPS+GLONASS receiver performance and accuracy.

10 Applications and Hints

10.1 Initial Module Start

After initially applying power to the module, it is necessary to start the internal firmware by toggling the ON_OFF pin. Toggling is done by pulling the signal to HIGH. This first toggling can be done after a LOW – HIGH transmission was detected at the WAKEUP pin or by simply waiting for 1s after power-up. In UART mode, output messages should immediately be displayed. If no messages then a new toggling should be applied.

10.2 Proper Shutdown

A controlled and orderly shutdown while the A5135-H is running in full power mode can be initiated by

- Pull the ON_OFF pin to low,
- Appropriate messages either in NMEA or OSP mode.

The shutdown is completed after maximum 1s. Therefore, the module should be supplied with voltage for that time after the shutdown sequence was initiated

10.3 SiRFaware™ Support

SiRFaware™ is a low-power operating mode that seeks to maintain low uncertainty in position, time, and frequency, and to maintain valid current Ephemeris using either data collected from satellites in view or Extended Ephemeris methods.

The SiRFaware™ mode is entered using the One Socket Protocol, an extension of the SiRF Binary Protocol. Please refer to the appropriate manual. To request a fix and to exit SiRFaware™ it is necessary to toggle the ON_OFF pin. Toggling is done by pulling the signal to HIGH.

10.4 Push-to-Fix Mode

Push-to-Fix mode is designed for the application that requires infrequent position reporting. The receiver generally stays in a low-power mode, up to 2 hours, but wakes up periodically to refresh position, time, ephemeris data and RTC calibration.

The push-to-fix mode is initialized and entered using the SiRF Binary Protocol. Please refer to the appropriate manual, paying attention to the paragraph titled “Set TricklePower Parameters”. To request a fix outside the specified duty cycles, it is necessary to toggle the ON_OFF pin. Toggling is done by pulling the signal to HIGH.

10.5 Hibernate Mode

To enter Hibernate Mode it is necessary to send a shutdown command or to toggle to ON_OFF pin by pulling the signal to LOW. Starting with firmware version 5.7.7 the according command is supported in NMEA and SiRF Binary mode. After a short delay, the module will switch into hibernate mode. The RTC will keep on running and

SRAM is backed with the typical current of 20 μ A drawn from Vcc. To wake the module up again, toggling the ON_OFF to HIGH.

10.6 Extended Ephemeris

The receiver can support two versions of using Extended Ephemeris (EE) data. The first one is the version, where the EE data are calculated on a server, are transmitted to device incorporating the receiver, and are then loaded into the receiver. These data can be valid for up to seven days.

The second version is the internal extrapolation of available “natural” Ephemeris data. This is done automatically and no external support is required. The internally calculated EE data are valid for up to 3 days.

The receiver firmware will define which set of EE data to use or will neglect those in case “natural” data are available. Both versions of EE data will help to further lower power consumption in SiRFaware™ mode.

10.7 TM_GPIO5 pin (1 pulse per second pin)

The 1PPS pin is an output pin.

In addition to precise positioning, GPS+GLONASS also allows for accurate timing due to the synchronized atomic clocks in the GPS+GLONASS satellites. While the current date and time is transmitted in NMEA sentences (UTC), an exact and accurate timing signal is provided via the 1PPS pin of the A5135-H GPS+GLONASS receiver.

Under good signal conditions the 1PPS signal comes between 620ns and 710ns after the full GPS+GLONASS system second which is accurately (around 10ns) synchronized to UTC. Therefore the 1 second clock can be derived and maintained within around 90ns under good signal conditions.

Note:

The 1PPS clock accuracy directly depends on the position accuracy!

The GPS+GLONASS signals travel at the speed of light, therefore a position inaccuracy directly translates into 1PPS inaccuracies.

10m position deviation \approx 33ns 1PPS deviation (typically)

100m position deviation \approx 333ns 1PPS deviation (typically)

The NMEA messages containing absolute timing information (UTC time) are provided around 300ms after the 1PPS signal typically. This may change with the GPS+GLONASS receiver setup.

The 1PPS signal is provided on a “as is” basis with no accuracy specification. It's NOT recommended to use 1PPS signal for accurate timing application. The given values are based on a 10 satellite, static GPS+GLONASS simulator scenario.

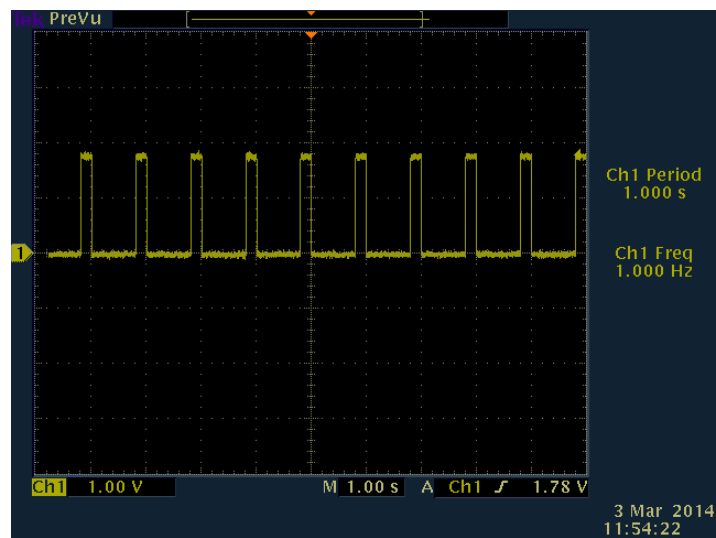

Figure 16: 1PPS waveform (reference)

10.8 5 Hz Navigation Update Rate

5Hz output rate supports rapid change of direction and improves accuracy on sport-related applications. 1Hz is the default update rate, to change to the 5Hz update rate, please refer to command below:

Enable 5Hz Navigation Update Rate command

- NMEA command MID103
\$PSRF103,00,6,00,0*23
- OSP command MID136
A0 A2 00 0E 88 00 00 04 04 00 00 00 00 00 00 00 0F 02 00 A1 B0 B3

Disable 5Hz and return to 1Hz Navigation Update Rate, command:

- NMEA command MID103
\$PSRF103,00,7,00,0*22
- OSP command MID136
A0 A2 00 0E 88 00 00 04 00 00 00 00 00 00 00 00 0F 02 00 9D B0 B3

11 Evaluation Kit EVA5135-H

For demonstration and easy evaluation of GPS+GLONASS performance Lantronix offers an evaluation kit (including one GPS+GLONASS A5135-H module). It contains a USB interface with according drivers to connect easily to a PC. The USB interface is an extension of the serial port 0, therefore sending NMEA sentences and accepting commands. At the same time, it provides power to the module. Accompanied by an antenna it offers a ready-to-go set.

For the development of new software and applications the Evaluation Kit also provides NMEA messages on CMOS level via a terminal plug.

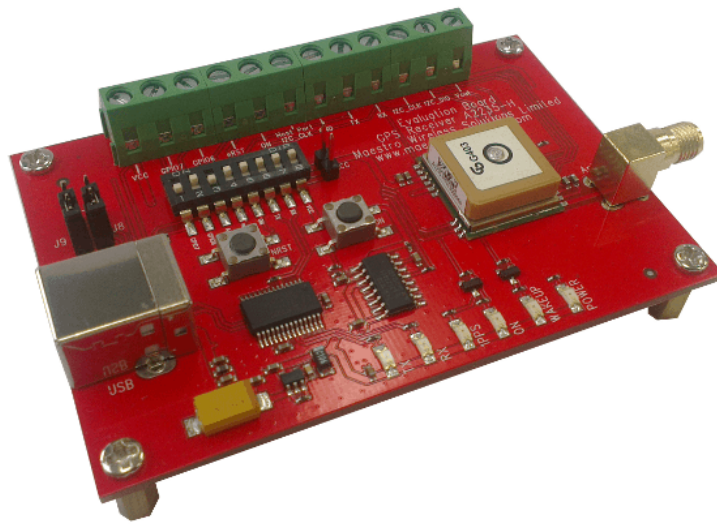

Figure 17: Evaluation kit EVA5135-H

For further information please contact Lantronix.

12 Related Information

12.1 Related Documents

- GPS+GLONASS Evaluation Kit EVA5135-H (Lantronix)
- Power ON/OFF Sequences and Power-On-Reset (POR) on A2100-AB (Lantronix)
- SiRF OSP Reference Manual (CSR)
- SiRF NMEA Reference Manual (CSR)

12.2 Related Tools

- GPS+GLONASS Cockpit (Lantronix)
- SiRFLive (CSR)