

CREALITY

3D Printer User Manual

3D打印机使用说明书

CR-5 Pro

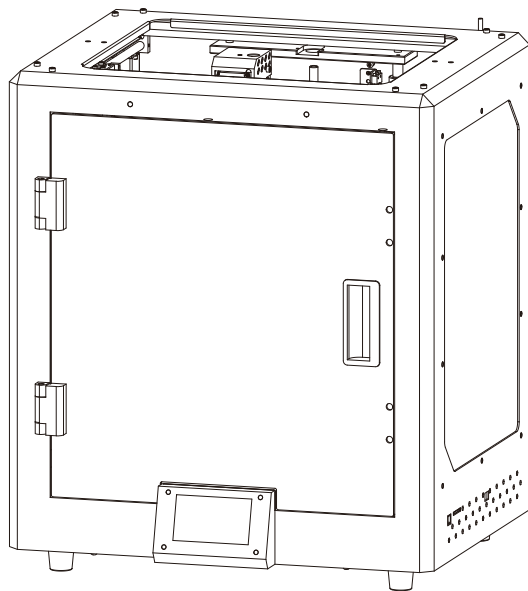

V1.0

Content 目录

Dear Consumers,

Thank you for choosing our products. For the best experience, please read the instructions before operating the Printer. Our teams will always be ready to render you the best services. Please contact us via the phone number or e-mail address provided at the end when you encounter any problem with the Printer.

For a better experience in using our product, you can also learn how to use the Printer in the following ways:

View the accompanied instructions and videos in the storage card.

Visit our official website www.creality.com to find relevant software/hardware information, contact details and operation and maintenance instructions.

尊敬的创想三维用户：

感谢您选择、使用创想三维的产品。为了您使用方便，请您在使用之前仔细阅读该说明书，并严格按照说明书的指示进行操作。

创想三维团队时刻准备为您提供优质的服务。在使用过程中无论遇到什么问题，请按照说明书结尾所提供的电话、邮箱与我们联系。

为了您能够更好地体验我们的产品，您还可以从以下方式获取设备操作知识：

随机使用说明：你可以在存储卡内找到相关使用说明及视频。

创想三维官网：www.cxsw3d.com 您可以登陆创想三维官网寻找相关软硬件、联系方式、设备操作、设备保养等信息。

A

Notes

使用须知

B

Assemble the 3D Printer

组装 3D 打印机

C

Use the 3D Printer

使用 3D 打印机

Level the Heated Bed

调平

Load Filament

装料

Start Printing

开始打印

NOTES 使用须知

1. Do not use the printer any way other than described herein in order to avoid personal injury or property damage.
2. Do not place the printer near any heat source or flammable or explosive objects. We suggest placing it in a well-ventilated, low-dust environment.
3. Do not expose the printer to violent vibration or any unstable environment, as this may cause poor print quality.
4. Before using experimental or exotic filaments, we suggest using standard filaments such as ABS or PLA to calibrate and test the machine.
5. Do not use any other power cable except the one supplied. Always use a grounded three-prong power outlet.
6. Do not touch the nozzle or printing surface during operation as they may be hot. Keep hands away from machine while in use to avoid burns or personal injury.
7. Do not wear gloves or loose clothing when operating the printer. Such cloths may become tangled in the printers moving parts leading to burns, possible bodily injury, or printer damage.
8. When cleaning debris from the printer hotend, always use the provided tools. Do not touch the nozzle directly when heated. This can cause personal injury.
9. Clean the printer frequently. Always turn the power off when cleaning, and wipe with a dry cloth to remove dust, adhered printing plastics or any other material off the frame, guide rails, or wheels. Use glass cleaner or isopropyl alcohol to clean the print surface before every print for consistent results.
10. Children under 10 years of age should not use the printer without supervision.
11. This machine is equipped with a security protection mechanism. Do not manually move the nozzle and printing platform mechanism manually while booting up, otherwise the device will automatically power off for safety.
12. Users shall comply with related nation and region's laws, regulations and ethical codes where the equipment or produced prints by it is used, and users of our product shall not use aforesaid products to print any end-use products, objects, parts or components or any other physical prints that violate the national or regional laws, regulations and ethical codes where herein referred product and produced prints by it is located.
13. Tips: Do not plug or unplug the power cord when power on.

1. 请勿尝试任何使用说明中没有描述的方法来使用本机，避免造成的意外人身伤害和财产损失；
2. 请勿将本机放置在易燃易爆物品或高热源附近，请将本机放置在通风、阴凉、少尘的环境内；
3. 请勿将打印机放置在振动较大或者其他不稳定的环境内，机器晃动会影响打印机打印质量；
4. 建议使用厂家推荐耗材，以免造成挤出头堵塞和机器损坏；
5. 请勿在安装过程中使用其他产品电源线代替，请使用本机附带的电源线，电源插头需接插在带有地线的三孔插座；
6. 请勿在打印机工作时接触喷嘴以及热床，以防止出现高温烫伤，造成人身伤害；
7. 请勿在操作机器时佩戴手套或缠绕物，以防可动部件对人身部件造成卷入挤压和切割伤害；
8. 在打印完毕后及时利用喷头的余温借助工具将喷头上的耗材清理干净，清理时请勿直接用手触摸喷头，以防出现烫伤；
9. 常做产品维护，定期在断电的情况下，用干布对打印机做机身清洁，拭去灰尘和粘结的打印材料、导轨上的异物；
10. 年龄在10岁以下的儿童，请勿在没有人员监督的情况下使用本机，以免造成人身伤害；
11. 本机设有安全保护机制，请勿在开机状态下手动快速移动喷头及打印平台机构，否则设备会自动断电关机保护；
12. 使用者应遵守设备打印产品与设备所在地及相应国家及地区法律、法规，恪守职业道德，严禁使用我司产品打印有违设备打印产品与设备所在地及相应国家、地区法律禁止的任何产品或物件。
13. 温馨提示：请勿带电插拔电线。

Introduction 设备简介

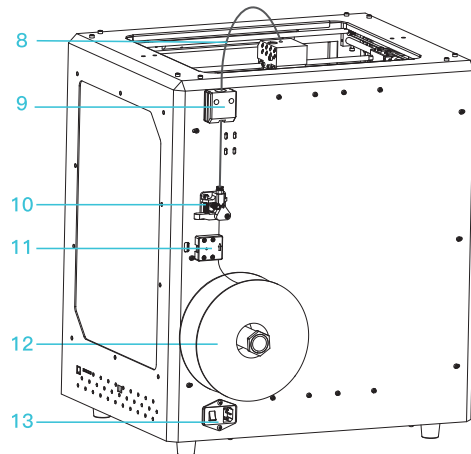
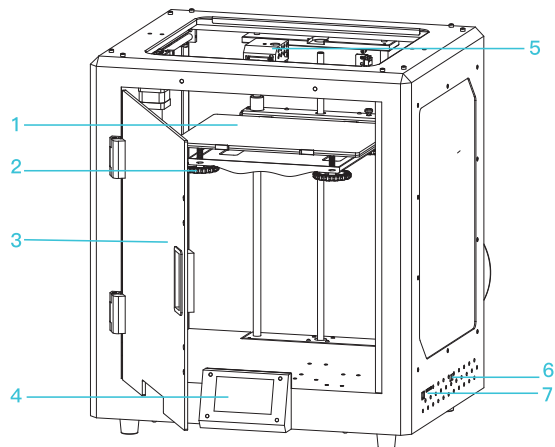

1 Printing Platform | 打印平台

2 Bed Leveling Nut | 调平螺母

3 Front Door | 前门

4 LCD Screen | LCD显示屏

5 Nozzle Kit | 喷头套件

6 Voltage switching switch | 电压切换拨动开关

7 Storage Card Slot & USB Port | 存储卡槽和USB接口

8 Teflon tube | 铁氟龙管

9 Wire Holder | 固定座

10 Remote Extruder | 远端挤出机

11 Filament Detector | 断料检测

12 Filament Holder & Filament | 料架及耗材

13 Power Cable Connection | 电源组合开关

Parameters 设备参数

Basic Parameters 基本参数	
Model 型号	CR-5 Pro
Printing Size 成型尺寸	300*225*380mm
Molding Tech 成型技术	FDM
Nozzle Number 喷头数量	1
Slice Thickness 切片层厚	0.1mm-0.4mm
Nozzle Diameter 喷嘴直径	Standard 0.4mm 标配0.4mm
Precision 打印精度	±0.1mm
Filament 打印材料	1.75mm PLA
File Format 切片支持格式	STL/OBJ/AMF
Working Mode 打印方式	Memory card offline or online printing 存储卡脱机或联机打印
Slice Software 可兼容切片软件	Creativity Slicer/Cura/Repetier-Host/Simplify3D
Power Supply 额定电压	Input 输入:AC115/230V 50/60Hz Output 输出:DC 24V
Total Power 额定功率	350W
Bed Temp 热床最高温度	≤100°C
Nozzle Temp 喷嘴最高温度	≤250°C
Resume Print 断电续打	Yes 有
Filament Detector 断料检测	Yes 有
Dual Z-Axis 双Z轴	No 无
language Selection 中英切换	English 中文
Operating System 电脑操作系统	Windows XP/7/8/10 MAC/Linux
Printing Speed 打印速度	≤180mm/s,Normal 正常为 30-60mm/s

Parts List 零部件清单



1 Tool Box | 工具包 x 1

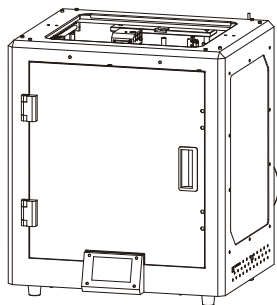

2 Printer | 主机 x 1



3 Filament | 耗材 x 1

Tool List 工具包清单



4 Hex keys, Wrench & Screwdriver
扳手和螺丝刀 x 1



5 Lubricating Grease x 1
润滑脂

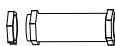

6 Spool & Nuts x 1
料管及料管螺母



7 M6 Socket Spanner x 1
M6套筒扳手



8 Spare Parts 1 x 1
备用喷嘴部件1



9 Spare Parts 2 x 2
备用喷嘴部件2



10 PTFE Tubing(Spare Part) x 1
铁氟龙管(备品)



11 Storage Card & Card Reader
存储卡和读卡器 x 1



12 Diagonal Pliers x 1
剪钳



13 Spade x 1
铲刀



14 Power Adapter x 1
电源线



15 Solid Glue x 1
固体胶



16 Nozzle Cleaner x 1
通针



17 Tweezers x 1
镊子



18 USB Cable x 1
USB线



19 Cable Ties x 1
扎带

1

Install The Spool 安装料管

Attach Spool Holder with included Nuts | 用尼龙螺母固定料管



6 Spool & Nuts x 1
料管及料管螺母

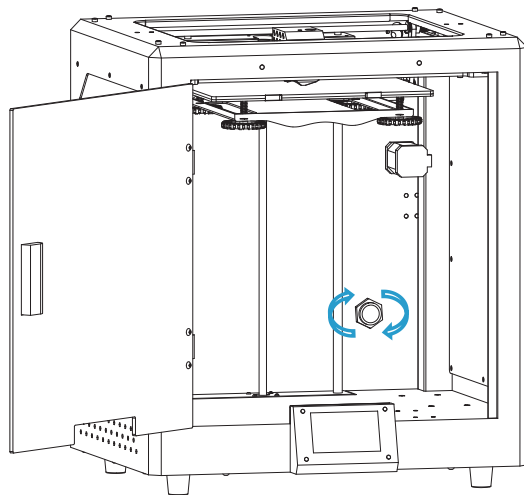
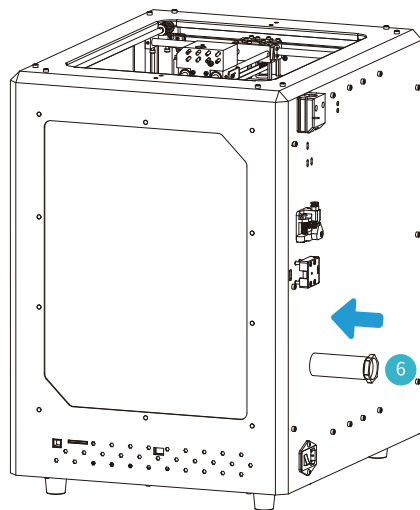

2

Power Supply Wiring

电源接线



14 Power Adapter x 1
电源线

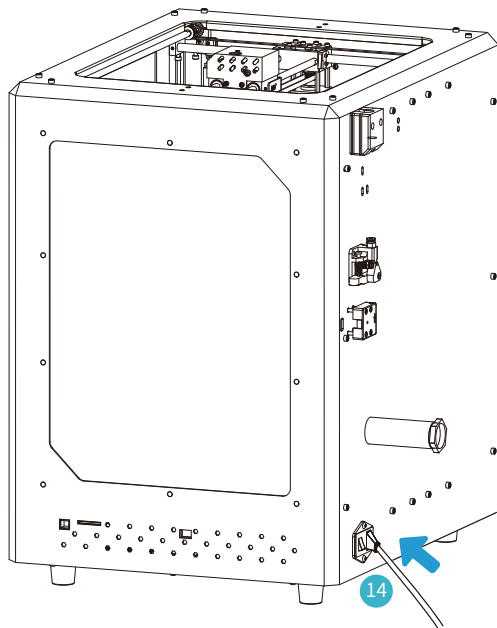

Caution

- Select the correct input voltage to match your local mains (115V/230V)
- Damage can occur if voltage is set incorrectly.
- Connect the power cord and turn the power switch to 1 to turn it on.
- Do not connect or disconnect the cables when the machine is powered on.
- 选择正确的输入电压以匹配您的本地电源 (115V/230V)
- 如果电压设置不正确, 可能会造成损坏。
- 连接电源线并将电源开关拨至1档即可开机。
- 当机器通电时, 请勿连接或断开连接线。

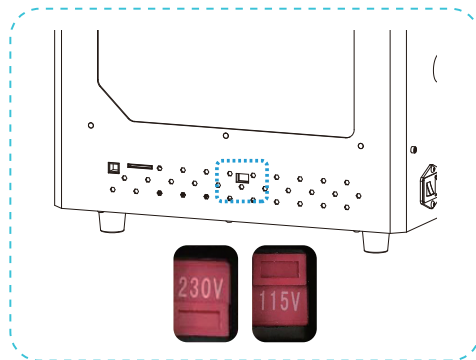

3

Bed Leveling 调平平台

1. Tighten four leveling nuts at the bottom of the platform before initial leveling. 2. Choose setting→leveling model →leveling, clicking number ①/②/③/④/⑤

1.初次调平前，拧紧平台底部的四个调平螺母 2.选择设置→手动调平→辅助调平，点击数字①/②/③/④/⑤

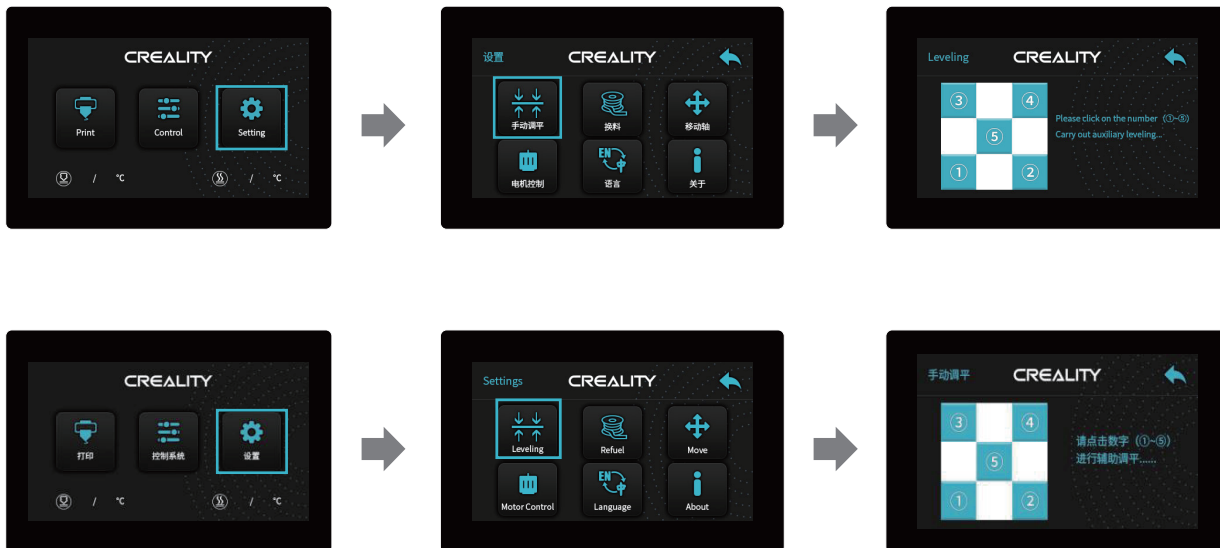

4

Move the nozzle near the top of the leveling screw, twist the screw left or right to make the distance between nozzle and the platform is as thick as a piece of A4 paper. Leveling the four corners in order, click ⑤ to verify whether the gap between nozzle and platform is proper or not.

移动喷嘴至螺丝上方附近。拧动螺丝，调节打印平台喷嘴使二者处于刚好贴合状态，间距约为0.1mm（一张A4纸的厚度）。按顺序调平四个角，点击⑤号，测试平台中间间隙是否合适。

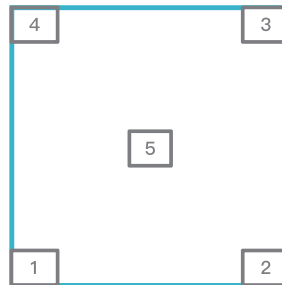
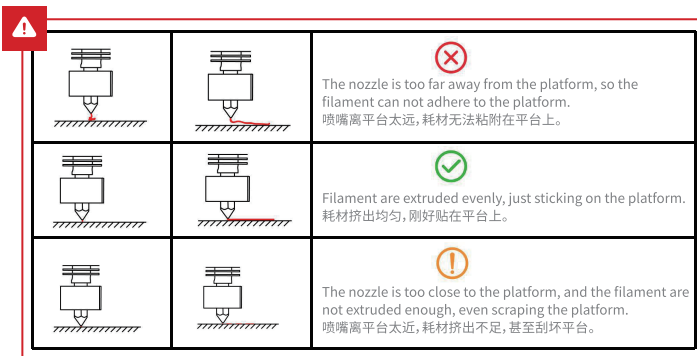
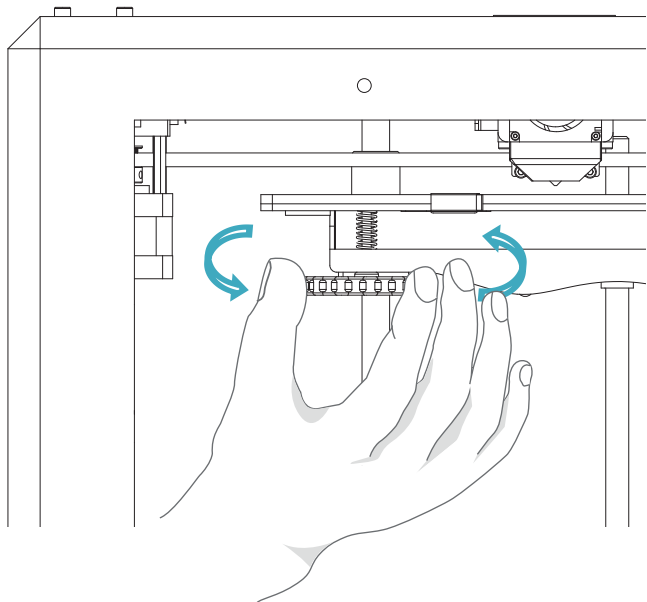

5

Use a piece of A4 paper (standard printer paper) to assist with the adjustment, making sure that the nozzle lightly scratches the paper. Complete the adjustment of the screw on all 4 corners. Repeat above steps 1-2 times if necessary. Keep adjusting until there is slight resistance on the A4 paper from the nozzle.

我们可以利用一张A4纸辅助调平,使喷嘴刚好能在A4纸上产生划痕。依次完成四个边上调平螺丝的调节。不断调整直到在拉动A4纸时能感受到来自喷嘴的轻微阻力。

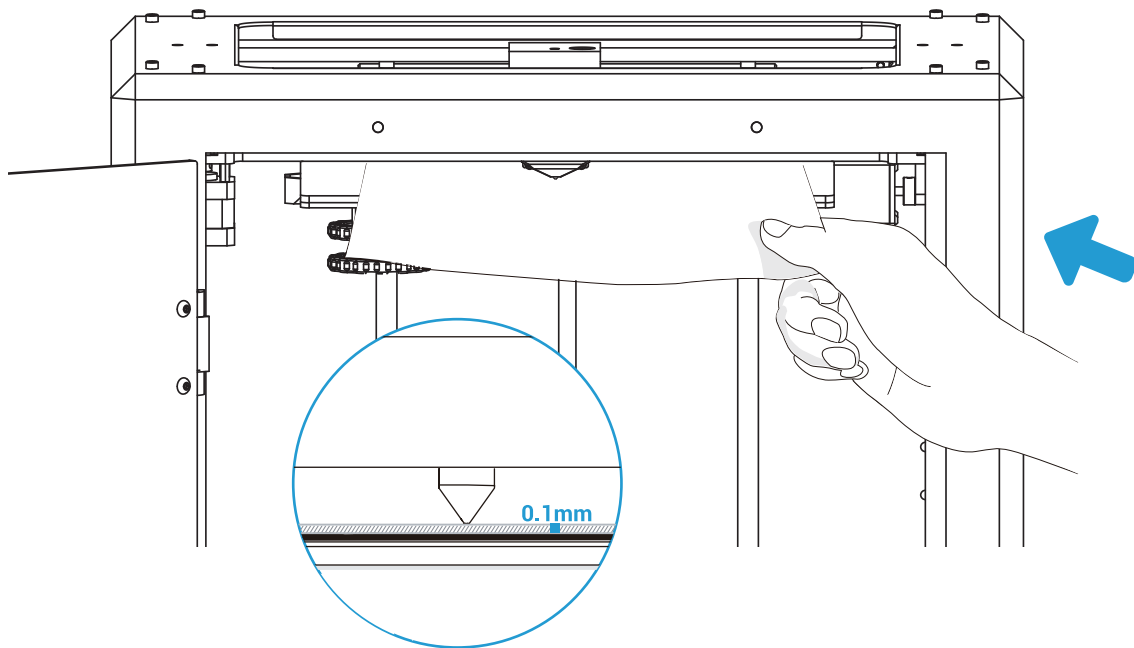

6

Preheating 预热

Method 1

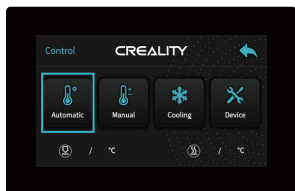
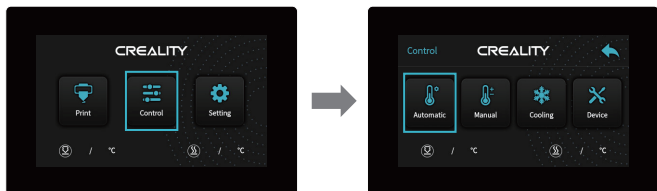

方法1



Method 2

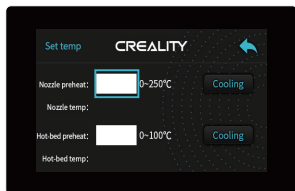
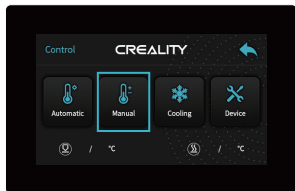
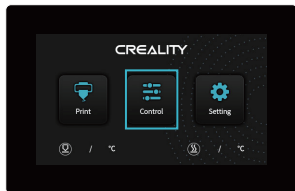

方法2



7

When you wait for the temperature to rise, hang the filament over the Filament Holder.

当您等待温度上升时,把耗材挂在料架上。



3 Filament | 耗材 x 1

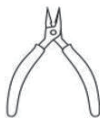

12 Diagonal Pliers x 1
剪钳

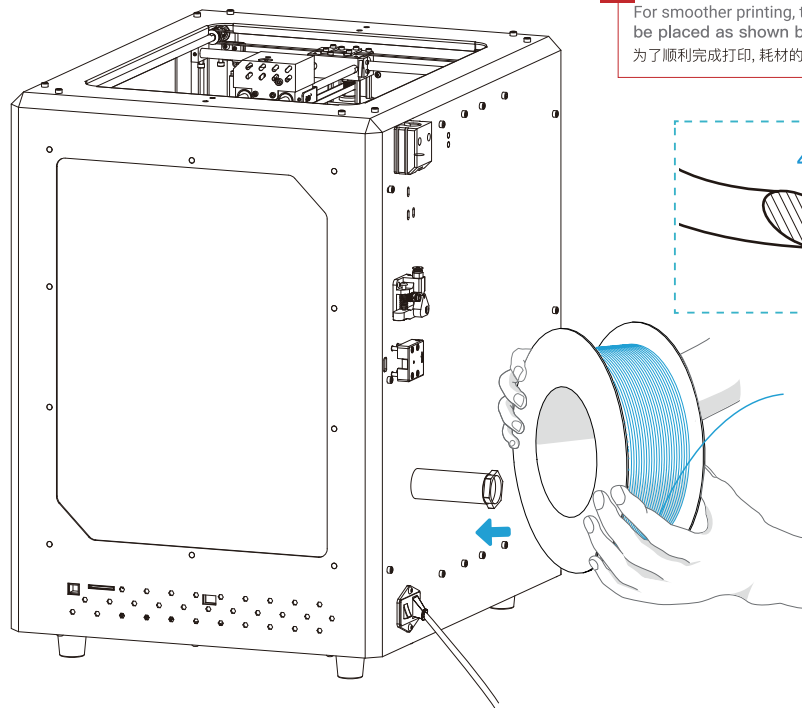

For smoother printing, the end of the filament should be placed as shown below.

为了顺利完成打印,耗材的末端位置应如图所示。

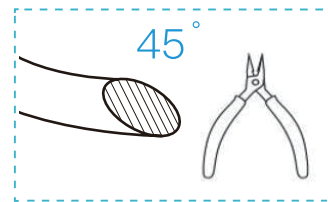

8

Load Filament 装料

When the temporary temperature hits the target temperature, feed in the filaments to the nozzle and keep await until you see liquid filament comes out of the nozzle.

当前温度达到目标温度时,将耗材插入挤出机小孔直至喷嘴位置,等看到喷嘴处有耗材流出即表示耗材已经装载完成。

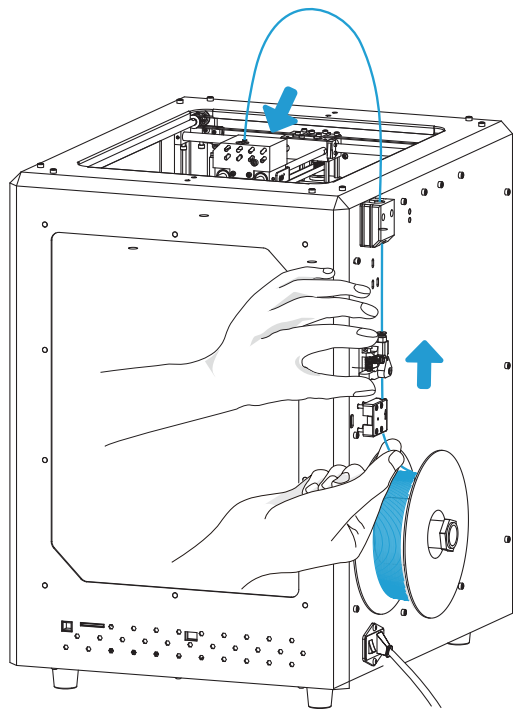

Tips: How to Replace the Filament?

1. Cutting filament near the Extruder and slowly feed new filament until they are fed into the new filament.
2. Withdrawing the filament quickly and feeding the new filament after nozzle preheated and filament pushed a little forward.

Tips: 如何更换耗材?

方法一、在靠近挤出机处将耗材剪断,将新耗材缓缓送入,直到耗材被送入导管为止。
方法二、预热喷嘴后,将耗材往前推进一下后,迅速抽出耗材,将新耗材送入。

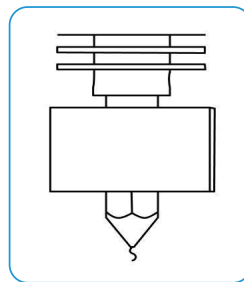

9

Start Printing

开始打印

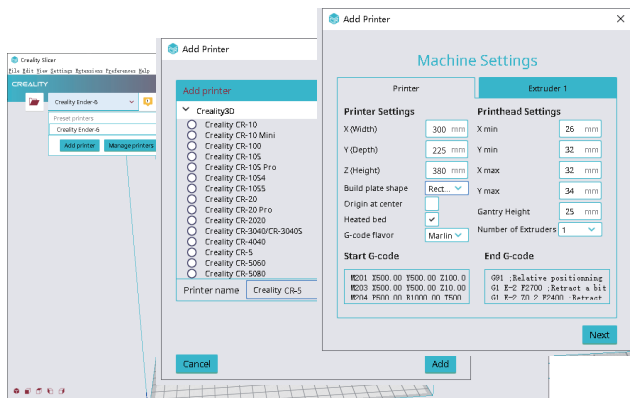

3. Select language→Next→Select your machine→Next→Finish.



1. Double click to install the software. | 安装软件
2. Double click to open the software. | 打开软件

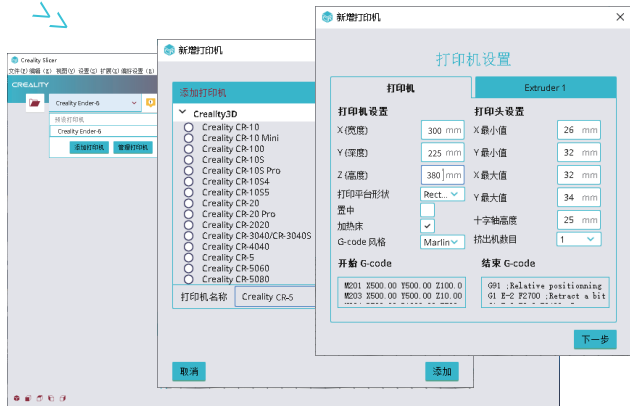

3. 依次选择语言→Next→选择对应机型→Next→Finish, 完成设置。

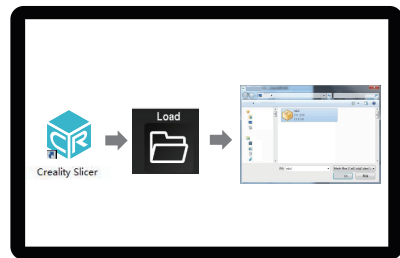

4. Open Creality 3D slicer → Load (Read file) → Select file.
打开创想三维切片软件→Load (读取文件) → 选择文件。

10

Start Printing

开始打印

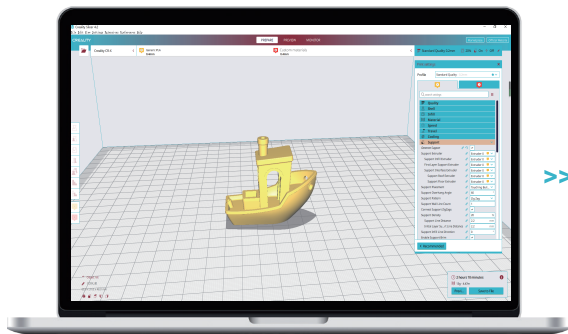

5. Generate G-code, and save the gcode file to storage card.
生成 G 代码→保存到存储卡

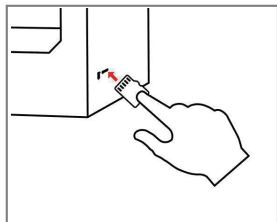

6. Insert the storage card → press the knob → select the menu → the file to be printed.
插入存储卡→按下旋钮→选择菜单→要打印的文件

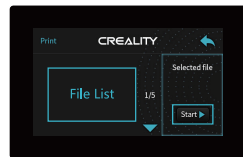
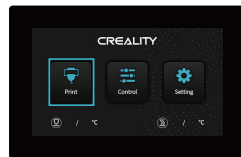

File names must be Latin letters or numbers, not Chinese characters or other special symbols
文件名需为拉丁字母或数字, 不能为汉字或其他特殊符号



Notes: For details on the software instructions, please refer to the slicing software manual in the memory card!
温馨提示: 软件使用说明详情, 请见存储卡内切片软件使用手册!

Circuit Wiring

电路接线

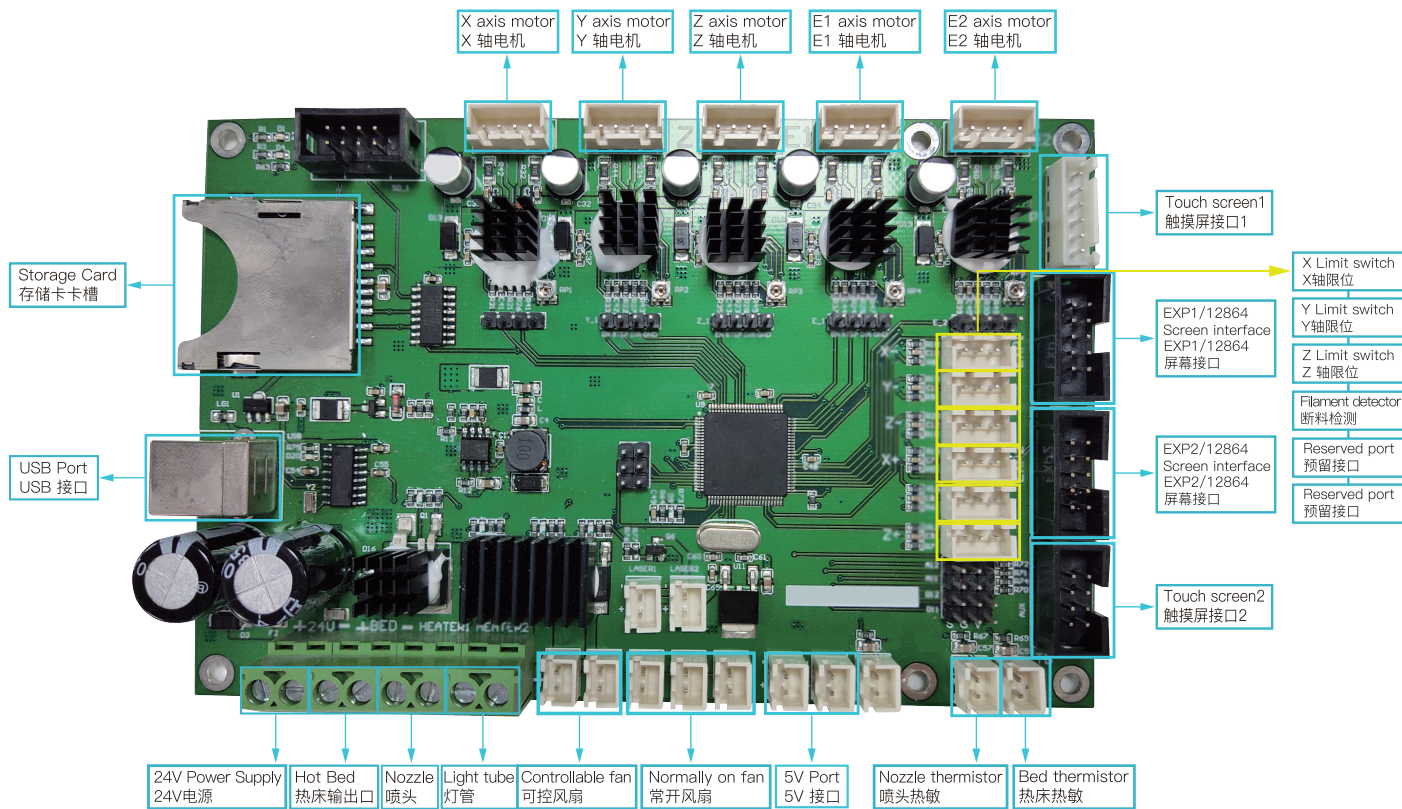

Trouble-Shooting

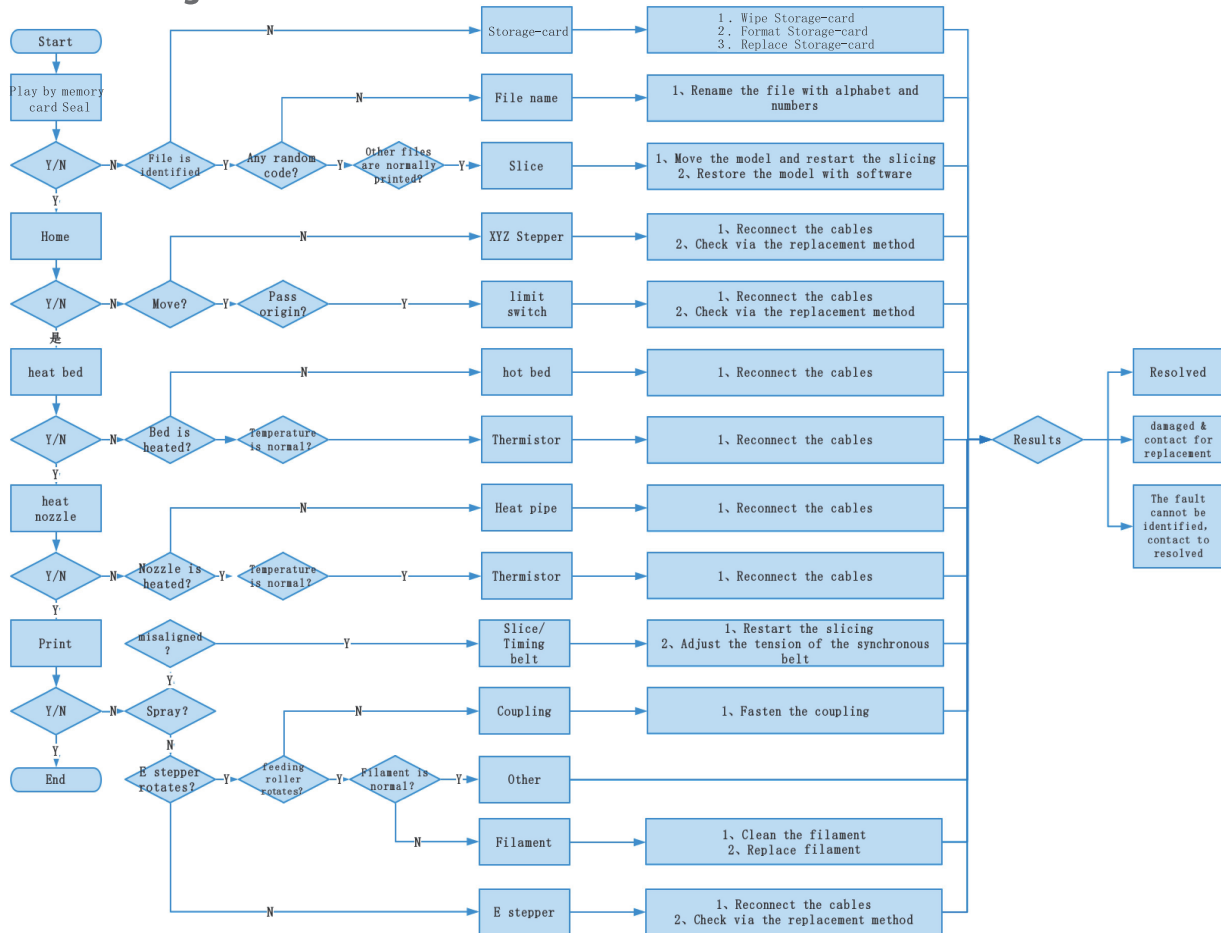

故障检修

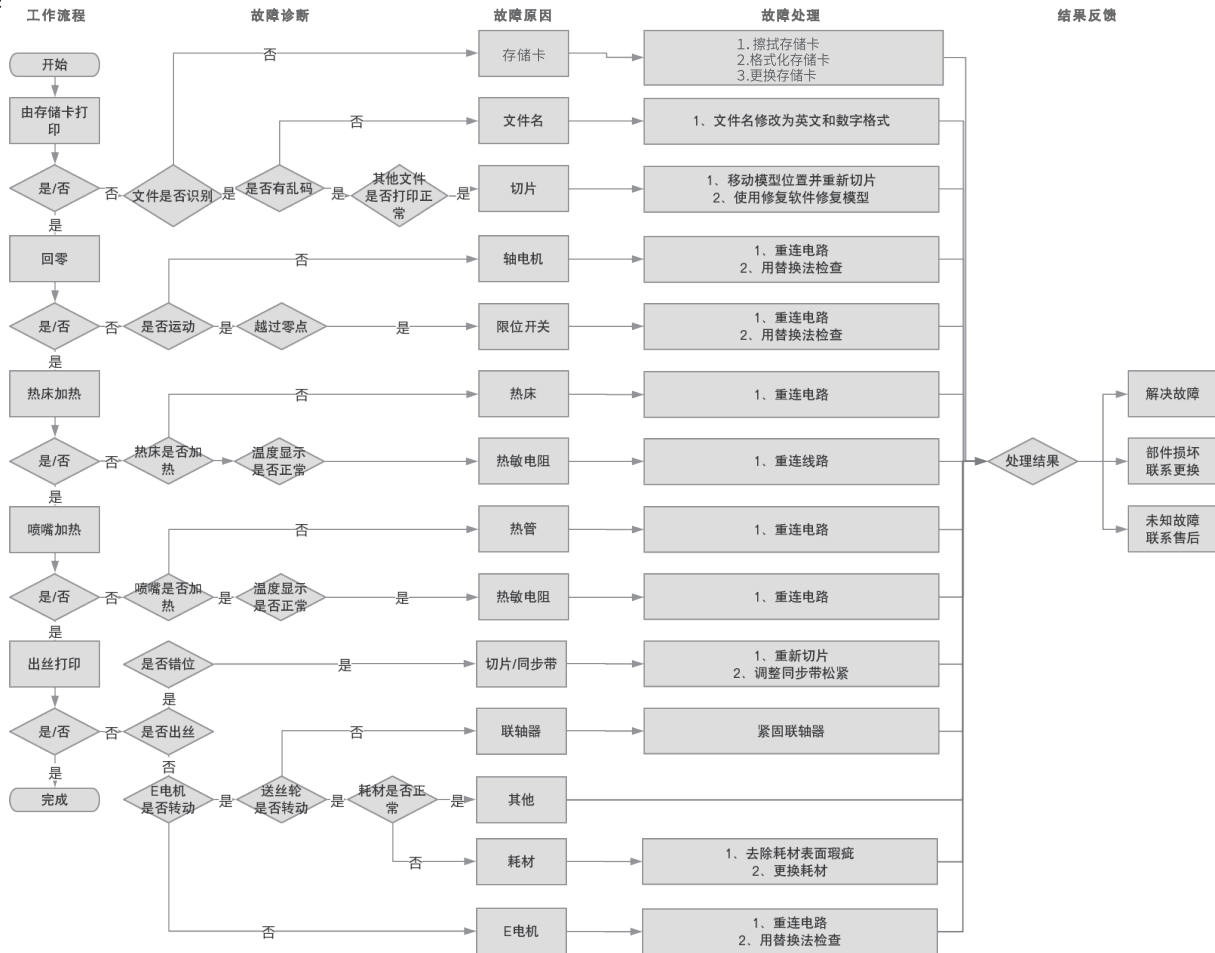

Due to the differences between different machine models, the physical objects and the final images can differ. The final explanation rights shall be reserved by Shenzhen Creality 3D Technology Co., Ltd.

因每款机型不同,实物与图可能有所差异,请以实物为准,最终解释归深圳市创想三维科技有限公司所有。



SHENZHEN CREALITY 3D TECHNOLOGY CO.,LTD.

11F & Room 1201,Block 3,JinChengYuan,Tongsheng Community,
Dalang,Longhua District,Shenzhen,China,518109
Official Website: www.creality.com
Tel: +86 755-8523 4565
E-mail: info@creality.com cs@creality.com



深圳市创想三维科技有限公司

深圳市龙华区大浪街道同胜社区金城工业园第三栋1201、11层
公司网站: www.cxsw3d.com
服务热线: 400 6133 882
0755-8523 4565

