



## Product Change Notification / SYST-19GIGG572

---

**Date:**

20-May-2022

**Product Category:**

Ethernet Switches

**PCN Type:**

Document Change

**Notification Subject:**

Data Sheet - KSZ8873MLL/FLL/RLL - Integrated 3-Port 10/100 Managed Switch with PHYs Revision

**Affected CPNs:**

[SYST-19GIGG572\\_Affected\\_CPN\\_05202022.pdf](#)

[SYST-19GIGG572\\_Affected\\_CPN\\_05202022.csv](#)

**Notification Text:**

SYST-19GIGG572

Microchip has released a new Product Documents for the KSZ8873MLL/FLL/RLL - Integrated 3-Port 10/100 Managed Switch with PHYs of devices. If you are using one of these devices please read the document located at [KSZ8873MLL/ FLL/ RLL - Integrated 3-Port 10/ 100 Managed Switch with PHYs](#).

**Notification Status:** Final

**Description of Change:** The following is the list of modifications:

1. Table 7-6, "SPI Input Timing Parameters": Updated SPI Input frequency from "5 MHz" to "25 MHz"
2. Table 7-7, "SPI Output Timing": Updated SPI Output frequency from "5 MHz" to "25 MHz"

**Impacts to Data Sheet:** See above details.

**Reason for Change:** To Improve Productivity

**Change Implementation Status:** Complete

**Date Document Changes Effective:** 20 May 2022

**NOTE:** Please be advised that this is a change to the document only the product has not been changed.

**Markings to Distinguish Revised from Unrevised Devices:** N/A

## **Attachments:**

[KSZ8873MLL/ FLL/ RLL - Integrated 3-Port 10/ 100 Managed Switch with PHYs](#)

Please contact your local [Microchip sales office](#) with questions or concerns regarding this notification.

## **Terms and Conditions:**

If you wish to receive Microchip PCNs via email please register for our PCN email service at our [PCN home page](#) select register then fill in the required fields. You will find instructions about registering for Microchips PCN email service in the [PCN FAQ](#) section.

If you wish to change your PCN profile, including opt out, please go to the [PCN home page](#) select login and sign into your myMicrochip account. Select a profile option from the left navigation bar and make the applicable selections.

Affected Catalog Part Numbers (CPN)

KSZ8873FLL  
KSZ8873MLL  
KSZ8873RLL  
KSZ8873FLLI  
KSZ8873MLLI  
KSZ8873RLLI  
KSZ8873RLLU  
KSZ8873RLLI-TR



# KSZ8873MLL/FLL/RLL

## Integrated 3-Port 10/100 Managed Switch with PHYs

### Features

- Advanced Switch Features
  - IEEE 802.1q VLAN Support for Up to 16 Groups (Full Range of VLAN IDs)
  - VLAN ID Tag/Untag Options, Per Port Basis
  - IEEE 802.1p/q Tag Insertion or Removal on a Per Port Basis (Egress)
  - Programmable Rate Limiting at the Ingress and Egress on a Per Port Basis
  - Broadcast Storm Protection with Percent Control (Global and Per Port Basis)
  - IEEE 802.1d Rapid Spanning Tree Protocol Support
  - Tail Tag Mode (1 byte Added before FCS) Support at Port 3 to Inform the Processor which Ingress Port Receives the Packet and its Priority
  - Bypass Feature that Automatically Sustains the Switch Function between Port 1 and Port 2 when CPU (Port 3 Interface) Goes into Sleep Mode
  - Self-Address Filtering
  - Individual MAC Address for Port 1 and Port 2
  - Supports RMI Interface and 50 MHz Reference Clock Output
  - MAC MII Interface Supports Both MAC and PHY Modes
  - IGMP Snooping (IPv4) Support for Multicast Packet Filtering
  - IPv4/IPv6 QoS Support
  - MAC Filtering Function to Forward Unknown Unicast Packets to Specified Port
- Comprehensive Configuration Register Access
  - Serial Management Interface (SMI) to All Internal Registers
  - MII Management (MIIM) Interface to PHY Registers
  - High Speed SPI and I<sup>2</sup>C Interface to All Internal Registers
  - I/O Pins Strapping and EEPROM to Program Selective Registers in Unmanaged Switch Mode
  - Control Registers Configurable on the Fly (Port-Priority, 802.1p/d/q, AN...)
- QoS/CoS Packet Prioritization Support
- Per Port, 802.1p and DiffServ-Based
  - Re-Mapping of 802.1p Priority Field Per Port basis, Four Priority Levels
- Proven Integrated 3-Port 10/100 Ethernet Switch
  - 3rd Generation Switch with Three MACs and Two PHYs Fully Compliant with IEEE 802.3u Standard
  - Non-Blocking Switch Fabric Ensures Fast Packet Delivery by Utilizing a 1k MAC Address Lookup Table and a Store-and-Forward Architecture
  - Full-Duplex IEEE 802.3x Flow Control (PAUSE) with Force Mode Option
  - Half-Duplex Back Pressure Flow Control
  - HP Auto MDI-X for Reliable Detection of and Correction for Straight-Through and Crossover Cables with Disable and Enable Option
  - LinkMD<sup>®</sup> TDR-Based Cable Diagnostics Permit Identification of Faulty Copper Cabling on Port 2
  - Comprehensive LED Indicator Support for Link, Activity, Full-/Half-Duplex and 10/100 Speed
  - HBM ESD Rating 3 kV
- Switch Monitoring Features
  - Port Mirroring/Monitoring/Sniffing: Ingress and/or Egress Traffic to Any Port or MII
  - MIB Counters for Fully Compliant Statistics Gathering 34 MIB Counters Per Port
  - Loopback Modes for Remote Diagnostic of Failure
- Low Power Dissipation
  - Full-Chip Software Power-Down (Register Configuration Not Saved)
  - Full-Chip Hardware Power-Down (Register Configuration Not Saved)
  - Energy-Detect Mode Support
  - Dynamic Clock Tree Shutdown Feature
  - Per Port Based Software Power-Save on PHY (Idle Link Detection, Register Configuration Preserved)
  - Voltages: Single 3.3V Supply with Internal 1.8V LDO for 3.3V VDDIO
  - Optional 3.3V, 2.5V, and 1.8V for VDDIO
  - Transceiver Power 3.3V for VDDA\_3.3
- Industrial Temperature Range: -40°C to +85°C
- Available in a 64-Pin LQFP, Lead-Free Package

### Applications

- VoIP Phone
- Set-Top/Game Box
- Automotive Ethernet
- Industrial Control
- IPTV POF
- SOHO Residential Gateway
- Broadband Gateway/Firewall/VPN
- Integrated DSL/Cable Modem
- Wireless LAN Access Point + Gateway
- Standalone 10/100 Switch

## TO OUR VALUED CUSTOMERS

It is our intention to provide our valued customers with the best documentation possible to ensure successful use of your Microchip products. To this end, we will continue to improve our publications to better suit your needs. Our publications will be refined and enhanced as new volumes and updates are introduced.

If you have any questions or comments regarding this publication, please contact the Marketing Communications Department via E-mail at [docerrors@microchip.com](mailto:docerrors@microchip.com). We welcome your feedback.

### Most Current Data Sheet

To obtain the most up-to-date version of this data sheet, please register at our Worldwide Web site at:

<http://www.microchip.com>

You can determine the version of a data sheet by examining its literature number found on the bottom outside corner of any page. The last character of the literature number is the version number, (e.g., DS30000000A is version A of document DS30000000).

### Errata

An errata sheet, describing minor operational differences from the data sheet and recommended workarounds, may exist for current devices. As device/documentation issues become known to us, we will publish an errata sheet. The errata will specify the revision of silicon and revision of document to which it applies.

To determine if an errata sheet exists for a particular device, please check with one of the following:

- Microchip's Worldwide Web site; <http://www.microchip.com>
- Your local Microchip sales office (see last page)

When contacting a sales office, please specify which device, revision of silicon and data sheet (include -literature number) you are using.

### Customer Notification System

Register on our web site at [www.microchip.com](http://www.microchip.com) to receive the most current information on all of our products.

## Table of Contents

1.0 Introduction .....	4
2.0 Pin Description and Configuration .....	5
3.0 Functional Description .....	12
4.0 Register Descriptions .....	38
5.0 Operational Characteristics .....	74
6.0 Electrical Characteristics .....	75
7.0 Timing Specifications .....	77
8.0 Reset Circuit .....	88
9.0 Selection of Isolation Transformers .....	89
10.0 Package Outline .....	90
Appendix A: Data Sheet Revision History .....	91
The Microchip Web Site .....	92
Customer Change Notification Service .....	92
Customer Support .....	92
Product Identification System .....	93

# KSZ8873MLL/FLL/RLL

## 1.0 INTRODUCTION

### 1.1 General Description

The KSZ8873MLL/FLL/RLL are highly integrated 3-port switch-on-a-chip ICs in the industry's smallest footprint. They are designed to enable a new generation of low port count, cost-sensitive, and power efficient 10/100 Mbps switch systems. Low power consumption, advanced power management, and sophisticated QoS features (e.g., IPv6 priority classification support) make these devices ideal for IPTV, IP-STB, VoIP, automotive, and industrial applications.

The KSZ8873 family is designed to support the GREEN requirement in today's switch systems. Advanced power management schemes include hardware power down, software power down, per port power down, and the energy detect mode that shuts down the transceiver when a port is idle.

KSZ8873MLL/FLL/RLL also offer a bypass mode. In this mode, the processor connected to the switch through the MII interface can be shut down without impacting the normal switch operation.

The configurations provided by the KSZ8873 family enables the flexibility to meet requirements of different applications:

- KSZ8873MLL: Two 10/100BASE-T/TX transceivers and one MII interface.
- KSZ8873RLL: Two 10/100BASE-T/TX transceivers and one RMII interface.
- KSZ8873FLL: Two 100BASE-FX transceivers and one MII interface.

The devices are available in RoHS-compliant 64-pin LQFP packages. Industrial-grade and qualified AEC-Q100 Automotive-grade versions are also available.

**FIGURE 1-1: SYSTEM BLOCK DIAGRAM**

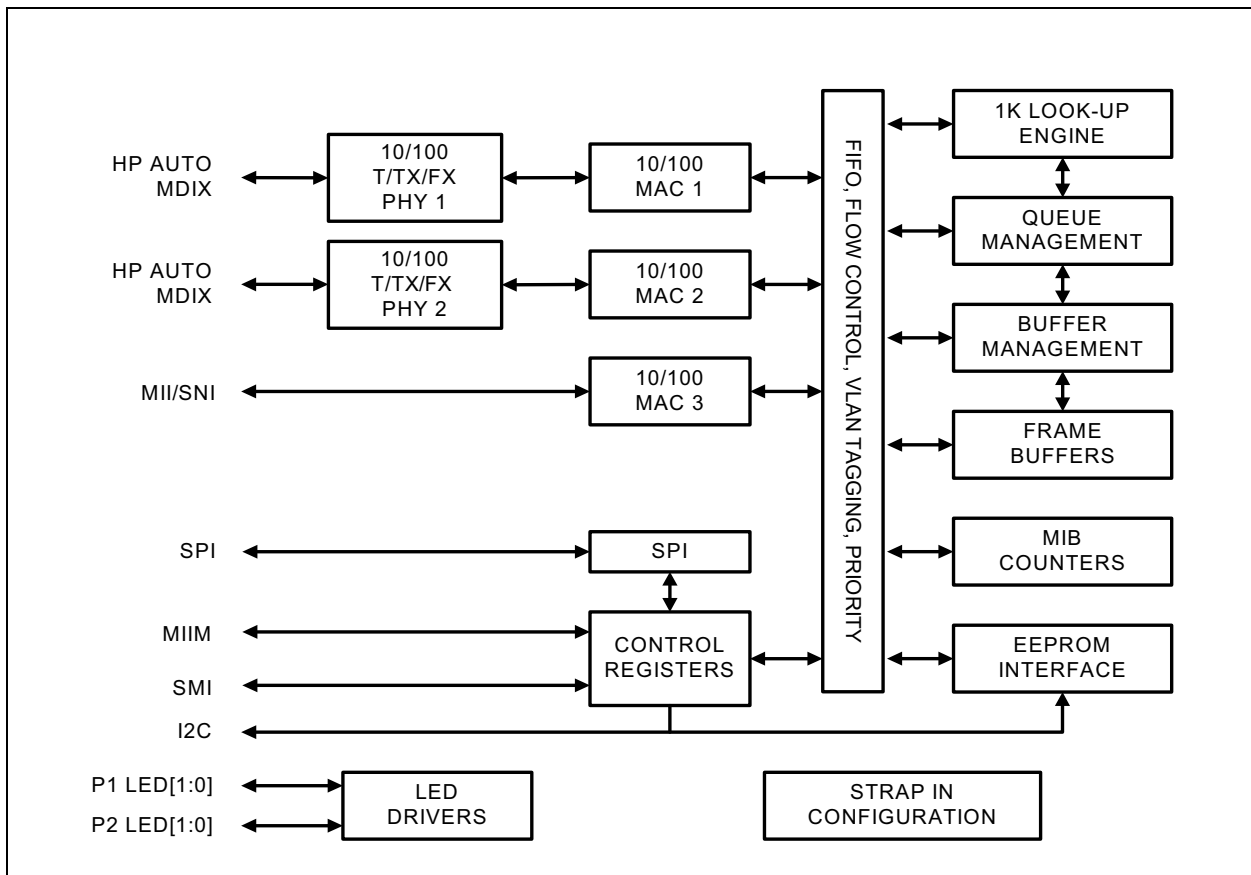

## 2.0 PIN DESCRIPTION AND CONFIGURATION

FIGURE 2-1: 64-PIN 10 MM X 10 MM LQFP ASSIGNMENT, (TOP VIEW)

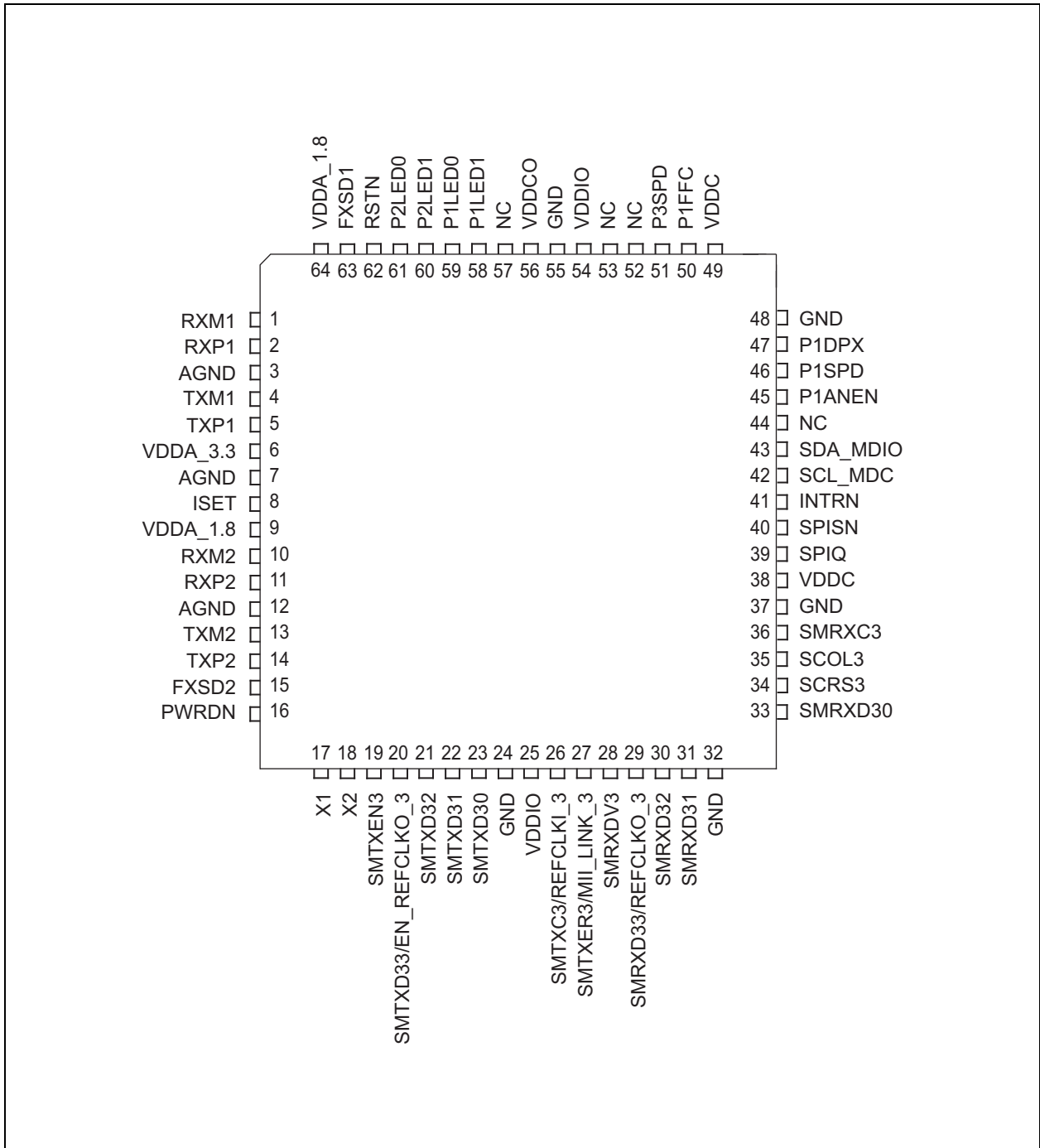



# KSZ8873MLL/FLL/RLL

TABLE 2-1: SIGNALS

Pin Number	Pin Name	Type Note 2-1	Description
1	RXM1	I/O	Physical receive or transmit signal (– differential)
2	RXP1	I/O	Physical receive or transmit signal (+ differential)
3	AGND	GND	Analog ground
4	TXM1	I/O	Physical transmit or receive signal (– differential)
5	TXP1	I/O	Physical transmit or receive signal (+ differential)
6	VDDA_3.3	P	3.3V analog V <sub>DD</sub>
7	AGND	GND	Analog ground
8	ISET	O	Set physical transmit output current. Pull-down this pin with an 11.8kΩ 1% resistor to ground.
9	VDDA_1.8	P	1.8V analog core power input from VDDCO (pin 56).
10	RXM2	I/O	Physical receive or transmit signal (– differential)
11	RXP2	I/O	Physical receive or transmit signal (+ differential)
12	AGND	GND	Analog ground
13	TXM2	I/O	Physical transmit or receive signal (– differential)
14	TXP2	I/O	Physical transmit or receive signal (+ differential)
15	FXSD2	I	MLL/RLL: connect to analog ground by pull-down resistor. FLL: Fiber signal detect/factory test pin
16	PWRDN	Ipu	Chip power down input (active-low)
17	X1	I	25 MHz or 50 MHz crystal/oscillator clock connections. Pins (X1, X2) connect to a crystal. If an oscillator is used, X1 connects to a 3.3V tolerant oscillator and X2 is a NC. Note: Clock is ±50 ppm for both crystal and oscillator, the clock should be applied to X1 pin before reset voltage goes high.
18	X2	O	
19	SMTXEN3	Ipu	Switch MII transmit enable
20	SMTXD33/ EN_REFCLKO_3	Ipu/I	MLL/FLL: Switch MII transmit data bit 3 RLL: <b>Strap option:</b> RMII mode Clock selection PU = Enable REFCLKO_3 output PD = Disable REFCLKO_3 output
21	SMTXD32/ NC	Ipu	MLL/FLL: Switch MII transmit data bit 2 RLL: No connection
22	SMTXD31	Ipu	Switch MII/RMII transmit data bit 1
23	SMTXD30	Ipu	Switch MII/RMII transmit data bit 0
24	GND	GND	Digital ground
25	VDDIO	P	3.3V, 2.5V, or 1.8V digital V <sub>DD</sub> input power supply for IO with well decoupling capacitors.

# KSZ8873MLL/FLL/RLL

TABLE 2-1: SIGNALS (CONTINUED)

Pin Number	Pin Name	Type Note 2-1	Description
26	SMTXC3/ REFCLKI_3	I/O	MLL/FLL: Switch MII transmit clock (MII mode only) Output in PHY MII mode and SNI mode Input in MAC MII and RMII mode. RLL: Reference clock input Note: Pull-down by resistor is needed if internal reference clock is used in RLL by register 198 bit 3.
27	SMTXER3/ MII_LINK_3	lpd	Switch MII transmit error in MII mode 0= MII link indicator from host in MII PHY mode. 1= No link on port 3 MII PHY mode and enable bypass mode.
28	SMRXDV3	lpu/O	Switch MII receive data valid <b>Strap option:</b> MII mode selection PU = PHY mode. PD = MAC mode (In MAC mode, port 3 MII has to connect a powered active external PHY for the normal operation)
29	SMRXD33/ REFCLKO_3	lpu/O	MLL/FLL: Switch MII receive data bit 3/ RLL: Output reference clock in RMII mode. <b>Strap option:</b> enable auto-negotiation on port 2 (P2ANEN) PU = enable P2ANEN PD = disable P2ANEN
30	SMRXD32	lpu/O	Switch MII receive data bit 2 <b>Strap option:</b> Force the speed on port 2 PU = force port 2 to 100BT if P2ANEN = 0 PD = force port 2 to 10BT if P2ANEN = 0
31	SMRXD31	lpu/O	Switch MII/RMII receive data bit 1 <b>Strap option:</b> Force duplex mode (P2DPX) PU = port 2 default to full-duplex mode if P2ANEN = 1 and auto-negotiation fails. Force port 2 in full-duplex mode if P2ANEN = 0. PD = Port 2 set to half-duplex mode if P2ANEN = 1 and auto-negotiation fails. Force port 2 in half-duplex mode if P2ANEN = 0.
32	GND	GND	Digital ground
33	SMRXD30	lpu/O	Switch MII/RMII receive data bit 0 <b>Strap option:</b> Force flow control on port 2 (P2FFC) PU = always enable (force) port 2 flow control feature, regardless of auto-negotiation result. PD = port 2 flow control feature is enabled by auto-negotiation result.
34	SCRS3/NC	lpu/O	MLL/FLL: Switch MII carrier sense RLL: No connection, internal pull-up. Note: For MLL/FLL part, when chip is configured as MAC mode, this pin should be driven from CRS pin of PHY or from CRS pin of FPGA with a logic of (TXEN   RXDV). If only full-duplex is used, then this pin should be pull-down by 1kΩ resistor.
35	SCOL3/NC	lpu/O	MLL/FLL: Switch MII collision detect RLL: No connection, internal pull-up.

# KSZ8873MLL/FLL/RLL

TABLE 2-1: SIGNALS (CONTINUED)

Pin Number	Pin Name	Type Note 2-1	Description
36	SMRXC3/NC	I/O	MLL/FLL: Switch MII receive clock. Output in PHY MII mode Input in MAC MII mode RLL: No Connection.
37	GND	GND	Digital ground
38	VDDC	P	1.8V digital core power input from VDDCO (pin 56).
39	SPIQ	Ipu/O	SPI slave mode: serial data output Note: an external pull-up is needed on this pin when it is in use. <b>Strap option:</b> XCLK Frequency Selection PU = 25 MHz PD = 50 MHz
40	SPISN	Ipu	SPI slave mode: chip select (active-low) When SPISN is high, the KSZ8873MLL/FLL/RLL is deselected and SPIQ is held in high impedance state. A high-to-low transition is used to initiate SPI data transfer. Note: an external pull-up is needed on this pin when it is in use.
41	INTRN	Opu	Interrupt Active-low signal to host CPU to indicate an interrupt status bit is set when lost link. Refer to register 187 and 188.
42	SCL_MDC	I/O	SPI slave mode/I <sup>2</sup> C slave mode: clock input I <sup>2</sup> C master mode: clock output MIIM clock input
43	SDA_MDIO	Ipu/O	SPI slave mode: serial data input I <sup>2</sup> C master/slave mode: serial data input/output MIIM: data input/output Note: an external pull-up is needed on this pin when it is in use.
44	NC	NC	Unused pin, only this NC pin can be pulled down by a pull-down resistor for better EMI.
45	P1ANEN	Ipu/O	PU = enable auto-negotiation on port 1 PD = disable auto-negotiation on port 1
46	P1SPD	Ipu/O	PU = force port 1 to 100BT if P1ANEN = 0 PD = force port 1 to 10BT if P1ANEN = 0
47	P1DPX	Ipu/O	PU = port 1 default to full-duplex mode if P1ANEN = 1 and auto-negotiation fails. Force port 1 in full-duplex mode if P1ANEN = 0. PD = port 1 default to half-duplex mode if P1ANEN = 1 and auto-negotiation fails. Force port 1 in half-duplex mode if P1ANEN = 0.
48	GND	GND	Digital ground
49	VDDC	P	1.8V digital core power input from VDDCO (Pin 56).
50	P1FFC	Ipu/O	PU = always enable (force) port 1 flow control feature PD = port 1 flow control feature enable is determined by auto-negotiation result.
51	P3SPD	Ipd/O	PU = force port 3 to 10BT PD = force port 3 to 100BT (default)

# KSZ8873MLL/FLL/RLL

**TABLE 2-1: SIGNALS (CONTINUED)**

Pin Number	Pin Name	Type Note 2-1	Description
52	NC	NC	Unused pin. No external connection.
53	NC	NC	Unused pin. No external connection.
54	VDDIO	P	3.3V, 2.5V or 1.8V digital V <sub>DD</sub> input power supply for IO with well decoupling capacitors.
55	GND	GND	Digital ground
56	VDDCO	P	1.8V core power voltage output (internal 1.8V LDO regulator output), this 1.8V output pin provides power to both VDDA_1.8 and VDDC input pins. Note: Internally 1.8V LDO regulator input comes from VDDIO. Do not connect an external power supply to VDDCO pin. The ferrite bead is requested between analog and digital 1.8V core power.
57	NC	NC	Unused pin. No external connection.
58	P1LED1	lpu/O	<b>Port 1 LED Indicators:</b> Default: Speed (refer to register 195 bit[5:4]) <b>Strap option:</b> Port 3 flow control selection (P3FFC) PU = always enable (force) port 3 flow control feature (default) PD = disable
59	P1LED0	lpd/O	<b>Port 1 LED Indicators:</b> Default: Link/Act. (refer to Register 195 bit[5:4]) <b>Strap option:</b> Port 3 duplex mode selection (P3DPX) PU = port 3 to half-duplex mode PD = port 3 to full-duplex mode (default) Note: P1LED0 has weaker internal pull-down, recommend an external pull-down by a 0.5 kΩ resistor.

# KSZ8873MLL/FLL/RLL

TABLE 2-1: SIGNALS (CONTINUED)

Pin Number	Pin Name	Type Note 2-1	Description															
60	P2LED1	Ipu/O	<p><b>Port 2 LED Indicators:</b> Default: Speed (refer to register 195 bit[5:4]) <b>Strap option:</b> Serial bus configuration</p> <p><b>Port 2 LED Indicators:</b> Default: Link/Act. (refer to register 195 bit[5:4]) <b>Strap option:</b> Serial bus configuration</p> <p>Serial bus configuration pins to select mode of access to KSZ8873MLL/FLL/RLL internal registers.</p> <p><b>[P2LED1, P2LED0] = [0, 0] — I<sup>2</sup>C master (EEPROM) mode</b> (If EEPROM is not detected, the KSZ8873MLL/FLL/RLL will be configured with the default values of its internal registers and the values of its strap-in pins.)</p>															
			<table border="1"> <thead> <tr> <th>Interface Signals</th> <th>Type</th> <th>Description</th> </tr> </thead> <tbody> <tr> <td>SPIQ</td> <td>O</td> <td>Not used (tri-stated)</td> </tr> <tr> <td>SCL_MDC</td> <td>O</td> <td>I<sup>2</sup>C clock</td> </tr> <tr> <td>SDA_MDIO</td> <td>I/O</td> <td>I<sup>2</sup>C data I/O</td> </tr> <tr> <td>SPISN</td> <td>I</td> <td>Not used</td> </tr> </tbody> </table>	Interface Signals	Type	Description	SPIQ	O	Not used (tri-stated)	SCL_MDC	O	I <sup>2</sup> C clock	SDA_MDIO	I/O	I <sup>2</sup> C data I/O	SPISN	I	Not used
			Interface Signals	Type	Description													
			SPIQ	O	Not used (tri-stated)													
			SCL_MDC	O	I <sup>2</sup> C clock													
			SDA_MDIO	I/O	I <sup>2</sup> C data I/O													
			SPISN	I	Not used													
			<p><b>[P2LED1, P2LED0] = [0, 1] — I<sup>2</sup>C slave mode</b> The external I<sup>2</sup>C master will drive the SCL_MDC clock. The KSZ8873MLL/FLL/RLL device addresses are: 1011_1111 &lt;read&gt; 1011_1110 &lt;write&gt;</p>															
			<table border="1"> <thead> <tr> <th>Interface Signals</th> <th>Type</th> <th>Description</th> </tr> </thead> <tbody> <tr> <td>SPIQ</td> <td>O</td> <td>Not used (tri-stated)</td> </tr> <tr> <td>SCL_MDC</td> <td>I</td> <td>I<sup>2</sup>C clock</td> </tr> <tr> <td>SDA_MDIO</td> <td>I/O</td> <td>I<sup>2</sup>C data I/O</td> </tr> <tr> <td>SPISN</td> <td>I</td> <td>Not used</td> </tr> </tbody> </table>	Interface Signals	Type	Description	SPIQ	O	Not used (tri-stated)	SCL_MDC	I	I <sup>2</sup> C clock	SDA_MDIO	I/O	I <sup>2</sup> C data I/O	SPISN	I	Not used
			Interface Signals	Type	Description													
SPIQ	O	Not used (tri-stated)																
SCL_MDC	I	I <sup>2</sup> C clock																
SDA_MDIO	I/O	I <sup>2</sup> C data I/O																
SPISN	I	Not used																
<p><b>[P2LED1, P2LED0] = [1, 0] — SPI slave mode</b></p>																		
<table border="1"> <thead> <tr> <th>Interface Signals</th> <th>Type</th> <th>Description</th> </tr> </thead> <tbody> <tr> <td>SPIQ</td> <td>O</td> <td>SPI data out</td> </tr> <tr> <td>SCL_MDC</td> <td>I</td> <td>SPI clock</td> </tr> <tr> <td>SDA_MDIO</td> <td>I</td> <td>SPI data in</td> </tr> <tr> <td>SPISN</td> <td>I</td> <td>SPI chip select</td> </tr> </tbody> </table>	Interface Signals	Type	Description	SPIQ	O	SPI data out	SCL_MDC	I	SPI clock	SDA_MDIO	I	SPI data in	SPISN	I	SPI chip select			
Interface Signals	Type	Description																
SPIQ	O	SPI data out																
SCL_MDC	I	SPI clock																
SDA_MDIO	I	SPI data in																
SPISN	I	SPI chip select																
<p><b>[P2LED1, P2LED0] = [1, 1] — SMI/MIIM mode</b> In SMI mode, the KSZ8873MLL/FLL/RLL provides access to all its internal 8-bit registers through its SCL_MDC and SDA_MDIO pins. In MIIM mode, the KSZ8873MLL/FLL/RLL provides access to its 16-bit MIIM registers through its SDC_MDC and SDA_MDIO pins.</p>																		
<table border="1"> <thead> <tr> <th>Interface Signals</th> <th>Type</th> <th>Description</th> </tr> </thead> <tbody> <tr> <td>SPIQ</td> <td>O</td> <td>Not used (tri-stated)</td> </tr> <tr> <td>SCL_MDC</td> <td>I</td> <td>I<sup>2</sup>C clock</td> </tr> <tr> <td>SDA_MDIO</td> <td>I/O</td> <td>I<sup>2</sup>C data I/O</td> </tr> <tr> <td>SPISN</td> <td>I</td> <td>Not used</td> </tr> </tbody> </table>	Interface Signals	Type	Description	SPIQ	O	Not used (tri-stated)	SCL_MDC	I	I <sup>2</sup> C clock	SDA_MDIO	I/O	I <sup>2</sup> C data I/O	SPISN	I	Not used			
Interface Signals	Type	Description																
SPIQ	O	Not used (tri-stated)																
SCL_MDC	I	I <sup>2</sup> C clock																
SDA_MDIO	I/O	I <sup>2</sup> C data I/O																
SPISN	I	Not used																
<table border="1"> <thead> <tr> <th>Interface Signals</th> <th>Type</th> <th>Description</th> </tr> </thead> <tbody> <tr> <td>SPIQ</td> <td>O</td> <td>SPI data out</td> </tr> <tr> <td>SCL_MDC</td> <td>I</td> <td>SPI clock</td> </tr> <tr> <td>SDA_MDIO</td> <td>I</td> <td>SPI data in</td> </tr> <tr> <td>SPISN</td> <td>I</td> <td>SPI chip select</td> </tr> </tbody> </table>	Interface Signals	Type	Description	SPIQ	O	SPI data out	SCL_MDC	I	SPI clock	SDA_MDIO	I	SPI data in	SPISN	I	SPI chip select			
Interface Signals	Type	Description																
SPIQ	O	SPI data out																
SCL_MDC	I	SPI clock																
SDA_MDIO	I	SPI data in																
SPISN	I	SPI chip select																
61	P2LED0	Ipu/O	<p><b>[P2LED1, P2LED0] = [1, 0] — SPI slave mode</b></p>															
			<table border="1"> <thead> <tr> <th>Interface Signals</th> <th>Type</th> <th>Description</th> </tr> </thead> <tbody> <tr> <td>SPIQ</td> <td>O</td> <td>SPI data out</td> </tr> <tr> <td>SCL_MDC</td> <td>I</td> <td>SPI clock</td> </tr> <tr> <td>SDA_MDIO</td> <td>I</td> <td>SPI data in</td> </tr> <tr> <td>SPISN</td> <td>I</td> <td>SPI chip select</td> </tr> </tbody> </table>	Interface Signals	Type	Description	SPIQ	O	SPI data out	SCL_MDC	I	SPI clock	SDA_MDIO	I	SPI data in	SPISN	I	SPI chip select
			Interface Signals	Type	Description													
			SPIQ	O	SPI data out													
			SCL_MDC	I	SPI clock													
			SDA_MDIO	I	SPI data in													
			SPISN	I	SPI chip select													
			<p><b>[P2LED1, P2LED0] = [1, 1] — SMI/MIIM mode</b> In SMI mode, the KSZ8873MLL/FLL/RLL provides access to all its internal 8-bit registers through its SCL_MDC and SDA_MDIO pins. In MIIM mode, the KSZ8873MLL/FLL/RLL provides access to its 16-bit MIIM registers through its SDC_MDC and SDA_MDIO pins.</p>															
			<table border="1"> <thead> <tr> <th>Interface Signals</th> <th>Type</th> <th>Description</th> </tr> </thead> <tbody> <tr> <td>SPIQ</td> <td>O</td> <td>Not used (tri-stated)</td> </tr> <tr> <td>SCL_MDC</td> <td>I</td> <td>I<sup>2</sup>C clock</td> </tr> <tr> <td>SDA_MDIO</td> <td>I/O</td> <td>I<sup>2</sup>C data I/O</td> </tr> <tr> <td>SPISN</td> <td>I</td> <td>Not used</td> </tr> </tbody> </table>	Interface Signals	Type	Description	SPIQ	O	Not used (tri-stated)	SCL_MDC	I	I <sup>2</sup> C clock	SDA_MDIO	I/O	I <sup>2</sup> C data I/O	SPISN	I	Not used
			Interface Signals	Type	Description													
SPIQ	O	Not used (tri-stated)																
SCL_MDC	I	I <sup>2</sup> C clock																
SDA_MDIO	I/O	I <sup>2</sup> C data I/O																
SPISN	I	Not used																
<p><b>[P2LED1, P2LED0] = [1, 0] — SPI slave mode</b></p>																		
<table border="1"> <thead> <tr> <th>Interface Signals</th> <th>Type</th> <th>Description</th> </tr> </thead> <tbody> <tr> <td>SPIQ</td> <td>O</td> <td>SPI data out</td> </tr> <tr> <td>SCL_MDC</td> <td>I</td> <td>SPI clock</td> </tr> <tr> <td>SDA_MDIO</td> <td>I</td> <td>SPI data in</td> </tr> <tr> <td>SPISN</td> <td>I</td> <td>SPI chip select</td> </tr> </tbody> </table>	Interface Signals	Type	Description	SPIQ	O	SPI data out	SCL_MDC	I	SPI clock	SDA_MDIO	I	SPI data in	SPISN	I	SPI chip select			
Interface Signals	Type	Description																
SPIQ	O	SPI data out																
SCL_MDC	I	SPI clock																
SDA_MDIO	I	SPI data in																
SPISN	I	SPI chip select																
<p><b>[P2LED1, P2LED0] = [1, 1] — SMI/MIIM mode</b> In SMI mode, the KSZ8873MLL/FLL/RLL provides access to all its internal 8-bit registers through its SCL_MDC and SDA_MDIO pins. In MIIM mode, the KSZ8873MLL/FLL/RLL provides access to its 16-bit MIIM registers through its SDC_MDC and SDA_MDIO pins.</p>																		
<table border="1"> <thead> <tr> <th>Interface Signals</th> <th>Type</th> <th>Description</th> </tr> </thead> <tbody> <tr> <td>SPIQ</td> <td>O</td> <td>Not used (tri-stated)</td> </tr> <tr> <td>SCL_MDC</td> <td>I</td> <td>I<sup>2</sup>C clock</td> </tr> <tr> <td>SDA_MDIO</td> <td>I/O</td> <td>I<sup>2</sup>C data I/O</td> </tr> <tr> <td>SPISN</td> <td>I</td> <td>Not used</td> </tr> </tbody> </table>	Interface Signals	Type	Description	SPIQ	O	Not used (tri-stated)	SCL_MDC	I	I <sup>2</sup> C clock	SDA_MDIO	I/O	I <sup>2</sup> C data I/O	SPISN	I	Not used			
Interface Signals	Type	Description																
SPIQ	O	Not used (tri-stated)																
SCL_MDC	I	I <sup>2</sup> C clock																
SDA_MDIO	I/O	I <sup>2</sup> C data I/O																
SPISN	I	Not used																
<table border="1"> <thead> <tr> <th>Interface Signals</th> <th>Type</th> <th>Description</th> </tr> </thead> <tbody> <tr> <td>SPIQ</td> <td>O</td> <td>SPI data out</td> </tr> <tr> <td>SCL_MDC</td> <td>I</td> <td>SPI clock</td> </tr> <tr> <td>SDA_MDIO</td> <td>I</td> <td>SPI data in</td> </tr> <tr> <td>SPISN</td> <td>I</td> <td>SPI chip select</td> </tr> </tbody> </table>	Interface Signals	Type	Description	SPIQ	O	SPI data out	SCL_MDC	I	SPI clock	SDA_MDIO	I	SPI data in	SPISN	I	SPI chip select			
Interface Signals	Type	Description																
SPIQ	O	SPI data out																
SCL_MDC	I	SPI clock																
SDA_MDIO	I	SPI data in																
SPISN	I	SPI chip select																

# KSZ8873MLL/FLL/RLL

**TABLE 2-1: SIGNALS (CONTINUED)**

Pin Number	Pin Name	Type Note 2-1	Description
62	RSTN	Ipu	Hardware reset pin (active-low)
63	FXSD1	I	MLL/RLL: Connect to analog ground by pull-down resistor FLL: Fiber signal detect
64	VDDA_1.8	P	1.8V analog $V_{DD}$ input power supply from VDDCO (Pin 56) through external ferrite bead and capacitors.

**Note 2-1** P = power supply  
GND = ground  
I = input  
O = output  
I/O = bi-directional  
Ipu/O = Input with internal pull-up during reset; output pin otherwise.  
Ipu = Input with internal pull-up.  
Ipd = Input with internal pull-down.  
Opu = Output with internal pull-up.  
Opd = Output with internal pull-down.  
Speed: Low (100BASE-TX), High (10BASE-T)  
Full-Duplex: Low (full-duplex), High (half-duplex)  
Activity: Toggle (transmit/receive activity)  
Link: Low (link), High (no link)

# KSZ8873MLL/FLL/RLL

---

---

## 3.0 FUNCTIONAL DESCRIPTION

The KSZ8873MLL/FLL/RLL contains two 10/100 physical layer transceivers and three MAC units with an integrated Layer 2 managed switch.

The KSZ8873MLL/FLL/RLL has the flexibility to reside in either a managed or unmanaged design. In a managed design, the host processor has complete control of the KSZ8873MLL/FLL/RLL via the SMI interface, MIIM interface, SPI bus, or I<sup>2</sup>C bus. An unmanaged design is achieved through I/O strapping and/or EEPROM programming at system reset time.

On the media side, the KSZ8873MLL/FLL/RLL supports IEEE 802.3 10BASE-T and 100BASE-TX on both PHY ports. Physical signal transmission and reception are enhanced through the use of patented analog circuitries that make the design more efficient and allow for lower power consumption and smaller chip die size.

### 3.1 Physical Layer Transceiver

#### 3.1.1 100BASE-TX TRANSMIT

The 100BASE-TX transmit function performs parallel-to-serial conversion, 4B/5B coding, scrambling, NRZ-to-NRZI conversion, and MLT3 encoding and transmission.

The circuitry starts with a parallel-to-serial conversion, which converts the MII data from the MAC into a 125 MHz serial bit stream. The data and control stream is then converted into 4B/5B coding, followed by a scrambler. The serialized data is further converted from NRZ-to-NRZI format, and then transmitted in MLT3 current output. The output current is set by an external 1% 11.8 k $\Omega$  resistor for the 1:1 transformer ratio.

The output signal has a typical rise/fall time of 4 ns and complies with the ANSI TP-PMD standard regarding amplitude balance, overshoot, and timing jitter. The wave-shaped 10BASE-T output is also incorporated into the 100BASE-TX transmitter.

#### 3.1.2 100BASE-TX RECEIVE

The 100BASE-TX receiver function performs adaptive equalization, DC restoration, MLT3-to-NRZI conversion, data and clock recovery, NRZI-to-NRZ conversion, de-scrambling, 4B/5B decoding, and serial-to-parallel conversion.

The receiving side starts with the equalization filter to compensate for inter-symbol interference (ISI) over the twisted pair cable. Because the amplitude loss and phase distortion is a function of the cable length, the equalizer must adjust its characteristics to optimize performance. In this design, the variable equalizer makes an initial estimation based on comparisons of incoming signal strength against some known cable characteristics, and then tunes itself for optimization. This is an ongoing process and self-adjusts against environmental changes such as temperature variations.

Next, the equalized signal goes through a DC restoration and data conversion block. The DC restoration circuit is used to compensate for the effect of baseline wander and to improve the dynamic range. The differential data conversion circuit converts the MLT3 format back to NRZI. The slicing threshold is also adaptive.

The clock recovery circuit extracts the 125 MHz clock from the edges of the NRZI signal. This recovered clock is then used to convert the NRZI signal into the NRZ format. This signal is sent through the de-scrambler followed by the 4B/5B decoder. Finally, the NRZ serial data is converted to the MII format and provided as the input data to the MAC.

#### 3.1.3 PLL CLOCK SYNTHESIZER

The KSZ8873MLL/FLL/RLL generates 125 MHz, 62.5 MHz, and 31.25 MHz clocks for system timing. Internal clocks are generated from an external 25 MHz or 50 MHz crystal or oscillator. KSZ8873RLL can generate a 50 MHz reference clock for the RMII interface.

#### 3.1.4 SCRAMBLER/DE-SCRAMBLER (100BASE-TX ONLY)

The purpose of the scrambler is to spread the power spectrum of the signal to reduce electromagnetic interference (EMI) and baseline wander. Transmitted data is scrambled through the use of an 11-bit wide linear feedback shift register (LFSR). The scrambler generates a 2047-bit non-repetitive sequence, and the receiver then de-scrambles the incoming data stream using the same sequence as at the transmitter.

#### 3.1.5 100BASE-FX OPERATION

100BASE-FX operation is similar to 100BASE-TX operation with the differences being that the scrambler/de-scrambler and MLT3 encoder/decoder are bypassed on transmission and reception. In addition, auto-negotiation is bypassed and auto MDI/MDI-X is disabled.

## 3.1.6 100BASE-FX SIGNAL DETECTION

In 100BASE-FX operation, FXSD (fiber signal detect), input pins 15 and 63, is usually connected to the fiber transceiver SD (signal detect) output pin. The fiber signal threshold can be selected by register 192 bit 7 and 6 respectively for port 1 and port 2. When FXSD is less than the threshold, no fiber signal is detected and a far-end fault (FEF) is generated. When FXSD is over the threshold, the fiber signal is detected.

Alternatively, the designer may choose not to implement the FEF feature. In this case, the FXSD input pin is tied high to force 100BASE-FX mode.

100BASE-FX signal detection is summarized in [Table 3-1](#):

**TABLE 3-1: FX SIGNAL THRESHOLD**

Register 192 Bit 7 (Port 2), Bit 6 (Port 1)	Fiber Signal Threshold at FXSD
1	2.0V
0	1.2V

To ensure proper operation, a resistive voltage divider is recommended to adjust the fiber transceiver SD output voltage swing to match the FXSD pin's input voltage threshold.

## 3.1.7 100BASE-FX FAR-END FAULT

A far-end fault (FEF) occurs when the signal detection is logically false on the receive side of the fiber transceiver. The KSZ8873FLL detects a FEF when its FXSD input is below the Fiber Signal Threshold. When a FEF is detected, the KSZ8873FLL signals its fiber link partner that a FEF has occurred by sending 84 1's followed by a zero in the idle period between frames. By default, FEF is enabled. FEF can be disabled through register setting.

## 3.1.8 10BASE-T TRANSMIT

The 10BASE-T driver is incorporated with the 100BASE-TX driver to allow for transmission using the same magnetics. They are internally wave-shaped and pre-emphasized into outputs with a typical 2.3V amplitude. The harmonic contents are at least 27 dB below the fundamental frequency when driven by an all-ones Manchester-encoded signal.

## 3.1.9 10BASE-T RECEIVE

On the receive side, input buffers and level detecting squelch circuits are employed. A differential input receiver circuit and a phase-locked loop (PLL) perform the decoding function. The Manchester-encoded data stream is separated into clock signal and NRZ data. A squelch circuit rejects signals with levels less than 400 mV or with short pulse widths to prevent noise at the RXP-or-RXM input from falsely triggering the decoder. When the input exceeds the squelch limit, the PLL locks onto the incoming signal and the KSZ8873MLL/FLL/RLL decodes a data frame. The receiver clock is maintained active during idle periods in between data reception.

## 3.1.10 MDI/MDI-X AUTO CROSSOVER

To eliminate the need for crossover cables between similar devices, the KSZ8873MLL/FLL/RLL supports HP Auto MDI/MDI-X and IEEE 802.3u standard MDI/MDI-X auto crossover. HP Auto MDI/MDI-X is the default.

The auto-sense function detects remote transmit and receive pairs and correctly assigns transmit and receive pairs for the KSZ8873MLL/FLL/RLL device. This feature is extremely useful when end users are unaware of cable types and also saves on an additional uplink configuration connection. The auto-crossover feature can be disabled through the port control registers or MIIM PHY registers.

The IEEE 802.3u standard MDI and MDI-X definitions are illustrated in [Table 3-2](#).

**TABLE 3-2: MDI/MDI-X PIN DEFINITIONS**

MDI		MDI-X	
RJ-45 Pins	Signals	RJ-45 Pins	Signals
1	TD+	1	RD+
2	TD-	2	RD-
3	RD+	3	TD+
6	RD-	6	TD-



# KSZ8873MLL/FLL/RLL

## 3.1.10.1 Straight Cable

A straight cable connects an MDI device to an MDI-X device, or an MDI-X device to an MDI device. [Figure 3-1](#) depicts a typical straight cable connection between a NIC card (MDI) and a switch or hub (MDI-X).

**FIGURE 3-1: TYPICAL STRAIGHT CABLE CONNECTION**

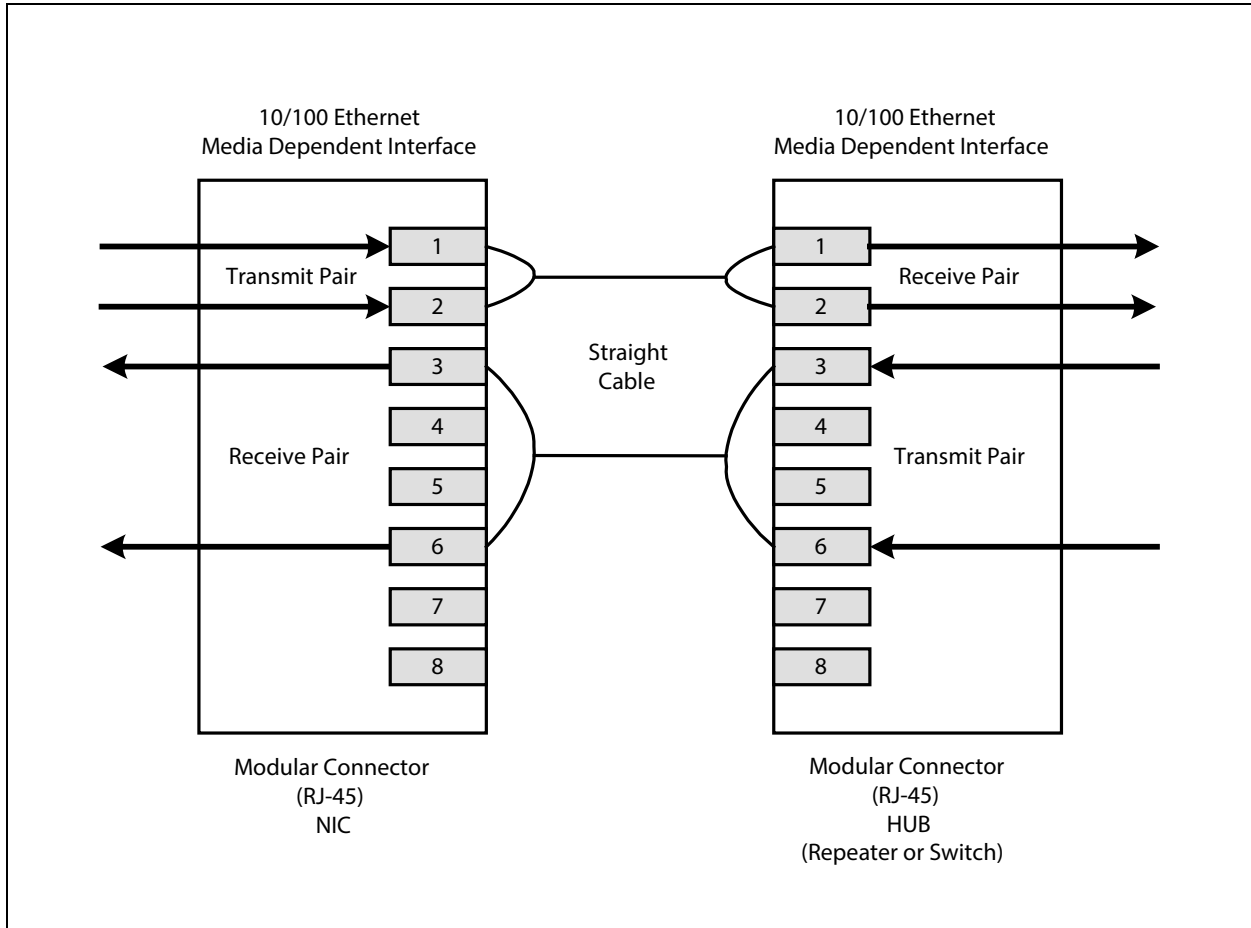

## 3.1.10.2 Crossover Cable

A crossover cable connects an MDI device to another MDI device, or an MDI-X device to another MDI-X device. [Figure 3-2](#) shows a typical crossover cable connection between two switches or hubs (two MDI-X devices).

**FIGURE 3-2: TYPICAL CROSSOVER CABLE CONNECTION**

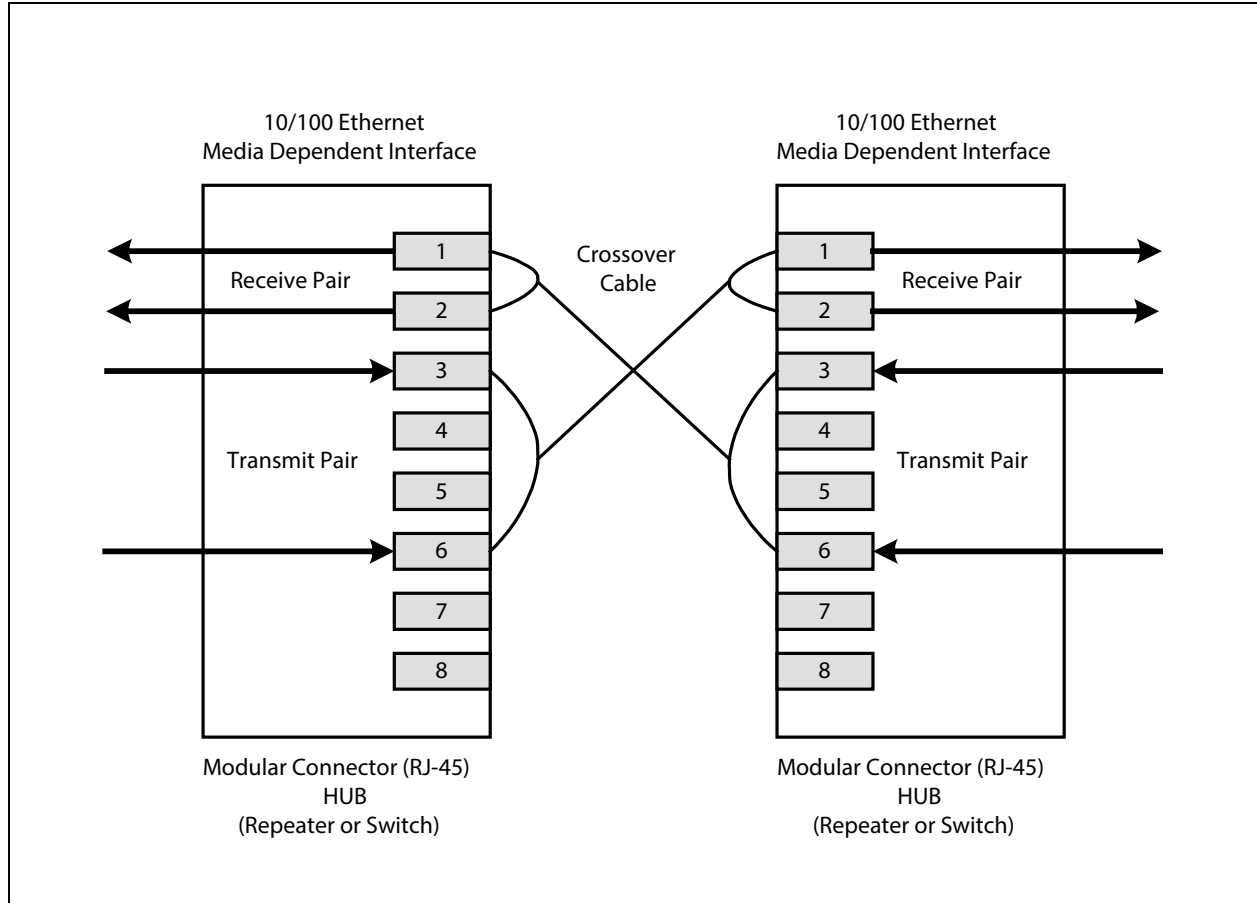

## 3.1.11 AUTO-NEGOTIATION

The KSZ8873MLL/FLL/RLL conforms to the auto-negotiation protocol, defined in Clause 28 of the IEEE 802.3u specification.

Auto-negotiation allows unshielded twisted pair (UTP) link partners to select the best common mode of operation. In auto-negotiation, link partners advertise their capabilities across the link to each other. If auto-negotiation is not supported or the KSZ8873MLL/FLL/RLL link partner is forced to bypass auto-negotiation, the KSZ8873MLL/FLL/RLL sets its operating mode by observing the signal at its receiver. This is known as parallel detection, and allows the KSZ8873MLL/FLL/RLL to establish link by listening for a fixed signal protocol in the absence of auto-negotiation advertisement protocol.

The link up process is shown in [Figure 3-3](#).

# KSZ8873MLL/FLL/RLL

FIGURE 3-3: AUTO-NEGOTIATION AND PARALLEL OPERATION

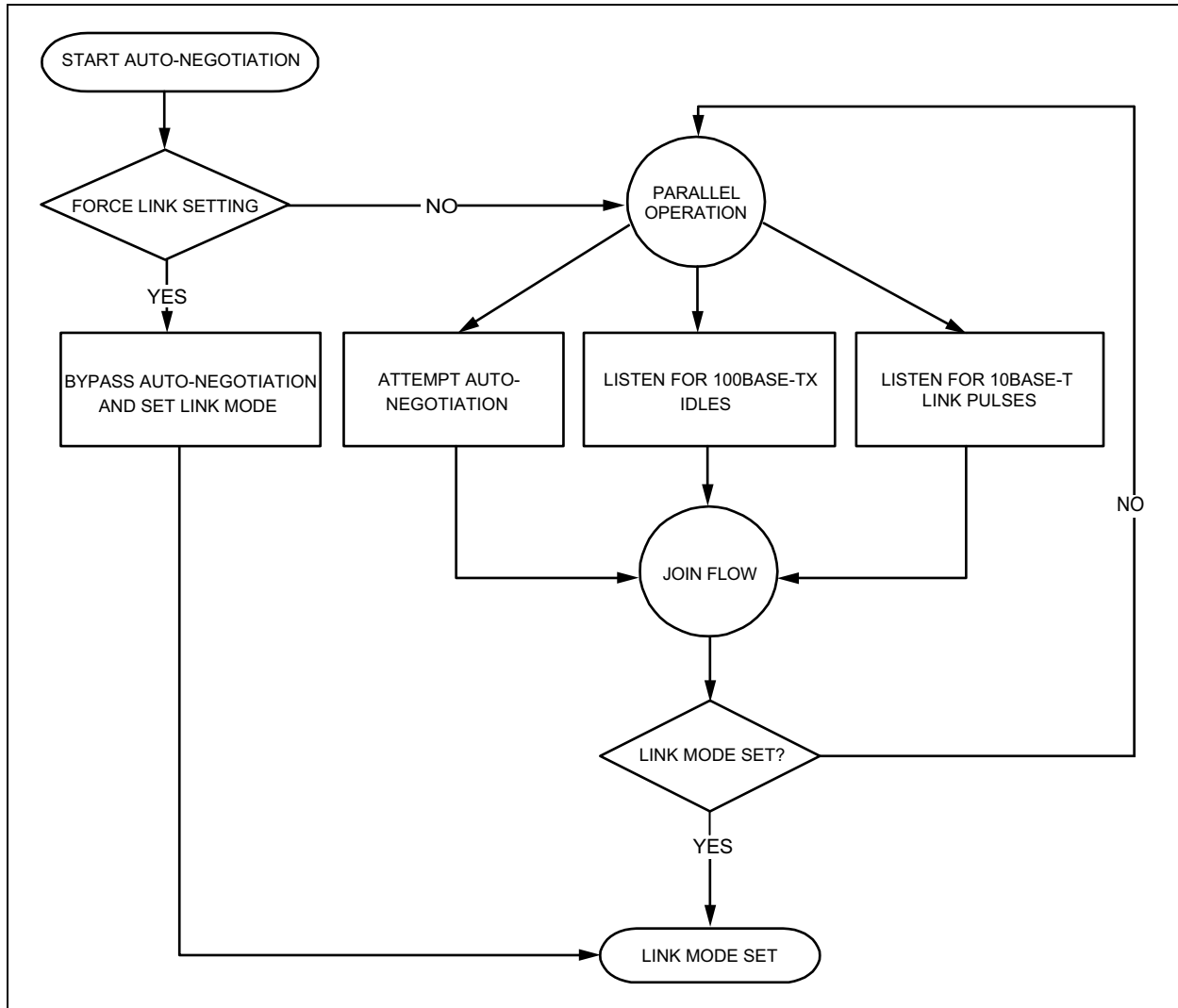

## 3.1.12 LINKMD<sup>®</sup> CABLE DIAGNOSTICS

KSZ8873MLL/FLL/RLL supports LinkMD. The LinkMD feature utilizes time domain reflectometry (TDR) to analyze the cabling plant for common cabling problems such as open circuits, short circuits, and impedance mismatches.

LinkMD works by sending a pulse of known amplitude and duration down the MDI and MDI-X pairs and then analyzes the shape of the reflected signal. Timing the pulse duration gives an indication of the distance to the cabling fault. Internal circuitry displays the TDR information in a user-readable digital format.

Cable diagnostics are only valid for copper connections and do not support fiber optic operation.

### 3.1.12.1 Access

LinkMD is initiated by accessing the PHY special control/status registers {26, 42} and the LinkMD result registers {27, 43} for ports 1 and 2 respectively; and in conjunction with the port registers control 13 for ports 1 and 2 respectively to disable Auto MDI/MDIX.

Alternatively, the MIIM PHY registers 0 and 29 can be used for LinkMD access.

### 3.1.12.2 Usage

The following is a sample procedure for using LinkMD with registers {42,43,45} on port 2.

1. Disable auto MDI/MDI-X by writing a '1' to register 45, bit [2] to enable manual control over the differential pair used to transmit the LinkMD pulse.
2. Start cable diagnostic test by writing a '1' to register 42, bit [4]. This enable bit is self-clearing.

3. Wait (poll) for register 42, bit [4] to return a '0', indicating cable diagnostic test is complete.
4. Read cable diagnostic test results in register 42, bits [6:5]. The results are as follows:
  - 00 = normal condition (valid test)
  - 01 = open condition detected in cable (valid test)
  - 10 = short condition detected in cable (valid test)
  - 11 = cable diagnostic test failed (invalid test)

The '11' case, invalid test, occurs when the KSZ8873MLL/FLL/RLL is unable to shut down the link partner. In this instance, the test is not run, because it would be impossible for the KSZ8873MLL/FLL/RLL to determine if the detected signal is a reflection of the signal generated or a signal from another source.

5. Get distance to fault by concatenating register 42, bit [0] and register 43, bits [7:0]; and multiplying the result by a constant of 0.4. The distance to the cable fault can be determined by the following formula:

## EQUATION 3-1:

$$D(\text{Distance to cable fault in meters}) = 0.4 \times (\text{Register 26 bit [0]} \times \text{Register 27 bits [7:0]})$$

Concatenated values of registers 42 and 43 are converted to decimal before multiplying by 0.4.

The constant (0.4) may be calibrated for different cabling conditions, including cables with a velocity of propagation that varies significantly from the norm.

## 3.2 Power Management

The KSZ8873MLL/FLL/RLL supports enhanced power management features in low power state with energy detection to ensure low-power dissipation during device idle periods. There are five operation modes under the power management function, which is controlled by two bits in Register 195 (0xC3) and one bit in Register 29 (0x1D), 45 (0x2D) as shown below:

Register 195 bit[1:0] = 00 Normal Operation Mode

Register 195 bit[1:0] = 01 Energy Detect Mode

Register 195 bit[1:0] = 10 Soft Power Down Mode

Register 195 bit[1:0] = 11 Power Saving Mode

Register 29, 45 bit 3 = 1 Port Based Power Down Mode

Table 3-3 indicates all internal function blocks status under four different power management operation modes.

**TABLE 3-3: INTERNAL FUNCTION BLOCK STATUS**

KSZ8873MLL/FLL/RLL Function Blocks	Power Management Operation Modes			
	Normal Mode	Power Saving Mode	Energy Detect Mode	Soft Power Down Mode
Internal PLL Clock	Enabled	Enabled	Disabled	Disabled
Tx/Rx PHY	Enabled	Rx unused block disabled	Energy detect at Rx	Disabled
MAC	Enabled	Enabled	Disabled	Disabled
Host Interface	Enabled	Enabled	Disabled	Disabled

### 3.2.1 NORMAL OPERATION MODE

This is the default setting bit[1:0]=00 in register 195 after the chip power-up or hardware reset. When KSZ8873MLL/FLL/RLL is in this normal operation mode, all PLL clocks are running, PHY and MAC are on, and the host interface is ready for CPU read or write.

# KSZ8873MLL/FLL/RLL

---

---

During the normal operation mode, the host CPU can set the bit[1:0] in register 195 to transit the current normal operation mode to any one of the other three power management operation modes.

## 3.2.2 POWER SAVING MODE

The power saving mode is entered when auto-negotiation mode is enabled, cable is disconnected, and by setting bit[1:0]=11 in register 195. When KSZ8873MLL/FLL/RLL is in this mode, all PLL clocks are enabled, MAC is on, all internal registers values will not change, and host interface is ready for CPU read or write. In this mode, it mainly controls the PHY transceiver on or off based on line status to achieve power saving. The PHY remains transmitting and only turns off the unused receiver block. Once activity resumes due to plugging a cable or attempting by the far end to establish link, the KSZ8873MLL/FLL/RLL can automatically enabled the PHY power up to normal power state from power saving mode.

During this power saving mode, the host CPU can set bit[1:0] =0 in register 195 to transit the current power saving mode to any one of the other three power management operation modes.

## 3.2.3 ENERGY DETECT MODE

The energy detect mode provides a mechanism to save more power than in the normal operation mode when the KSZ8873MLL/FLL/RLL is not connected to an active link partner. In this mode, the device will save up to 50% of the power. If the cable is not plugged, the KSZ8873MLL/FLL/RLL can automatically enter a low-power state, the energy detect mode. In this mode, KSZ8873MLL/FLL/RLL will keep transmitting 120 ns width pulses at a rate of 1 pulse/second. Once activity resumes due to plugging a cable or an attempt by the far end to establish link, the KSZ8873MLL/FLL/RLL can automatically power up to normal power state in energy detect mode.

Energy detect mode consists of two states, normal power state and low power state. While in low power state, the KSZ8873MLL/FLL/RLL reduces power consumption by disabling all circuitry except the energy detect circuitry of the receiver. The energy detect mode is entered by setting bit[1:0]=01 in register 195. When the KSZ8873MLL/FLL/RLL is in this mode, it will monitor the cable energy. If there is no energy on the cable for a time longer than pre-configured value at bit[7:0] Go-Sleep time in register 196, KSZ8873MLL/FLL/RLL will go into a low power state. When KSZ8873MLL/FLL/RLL is in low power state, it will keep monitoring the cable energy. Once the energy is detected from the cable, KSZ8873MLL/FLL/RLL will enter normal power state. When KSZ8873MLL/FLL/RLL is at normal power state, it is able to transmit or receive packet from the cable.

It will save about 87% of the power when MII interface is in PHY mode, Pin SMTXER3/MII\_LINK\_3 is connected to High, register 195 bit [1:0] =01, bit 2 =1 (Disable PLL), no cables are connected.

## 3.2.4 SOFT POWER DOWN MODE

The soft power down mode is entered by setting bit[1:0]=10 in register 195. When KSZ8873MLL/FLL/RLL is in this mode, all PLL clocks are disabled, the PHY and the MAC are off, all internal registers values will not change. When the host set bit[1:0]=00 in register 195, this device will be back from current soft power down mode to normal operation mode.

## 3.2.5 PORT-BASED POWER DOWN MODE

In addition, the KSZ8873MLL/FLL/RLL features a per-port power down mode. To save power, a PHY port that is not in use can be powered down via port control register 29 or 45 bit 3, or MIIM PHY register. It saves about 15 mA per port.

## 3.2.6 HARDWARE POWER DOWN

KSZ8873 supports a hardware power down mode. When the pin PWRDN is activated low, the entire chip is powered down.

## 3.3 MAC and Switch

### 3.3.1 ADDRESS LOOKUP

The internal lookup table stores MAC addresses and their associated information. It contains a 1K unicast address table plus switching information.

The KSZ8873MLL/FLL/RLL is guaranteed to learn 1K addresses and distinguishes itself from hash-based lookup tables, which depending on the operating environment and probabilities, may not guarantee the absolute number of addresses it can learn.

### 3.3.2 LEARNING

The internal lookup engine updates its table with a new entry if the following conditions are met:

- The received packet's source address (SA) does not exist in the lookup table.
- The received packet is good; the packet has no receiving errors, and is of legal length.

The lookup engine inserts the qualified SA into the table, along with the port number and time stamp. If the table is full, the last entry of the table is deleted to make room for the new entry.

### 3.3.3 MIGRATION

The internal lookup engine also monitors whether a station has moved. If a station has moved, it will update the table accordingly. Migration happens when the following conditions are met:

- The received packet's SA is in the table, but the associated source port information is different.
- The received packet is good; the packet has no receiving errors, and is of legal length.

The lookup engine will update the existing record in the table with the new source port information.

### 3.3.4 AGING

The lookup engine updates the time stamp information of a record whenever the corresponding SA appears. The time stamp is used in the aging process. If a record is not updated for a period of time, the lookup engine removes the record from the table. The lookup engine constantly performs the aging process and will continuously remove aging records. The aging period is about 200 seconds. This feature can be enabled or disabled through register 3 (0x03) bit [2].

### 3.3.5 FORWARDING

The KSZ8873MLL/FLL/RLL forwards packets using the algorithm that is depicted in the following flowcharts. [Figure 3-4](#) shows stage one of the forwarding algorithm where the search engine looks up the VLAN ID, static table, and dynamic table for the destination address, and comes up with "port to forward 1" (PTF1). PTF1 is then further modified by spanning tree, IGMP snooping, port mirroring, and port VLAN processes to come up with "port to forward 2" (PTF2), as shown in [Figure 3-5](#). The packet is sent to PTF2.

# KSZ8873MLL/FLL/RLL

FIGURE 3-4: DESTINATION ADDRESS LOOKUP FLOW CHART, STAGE 1

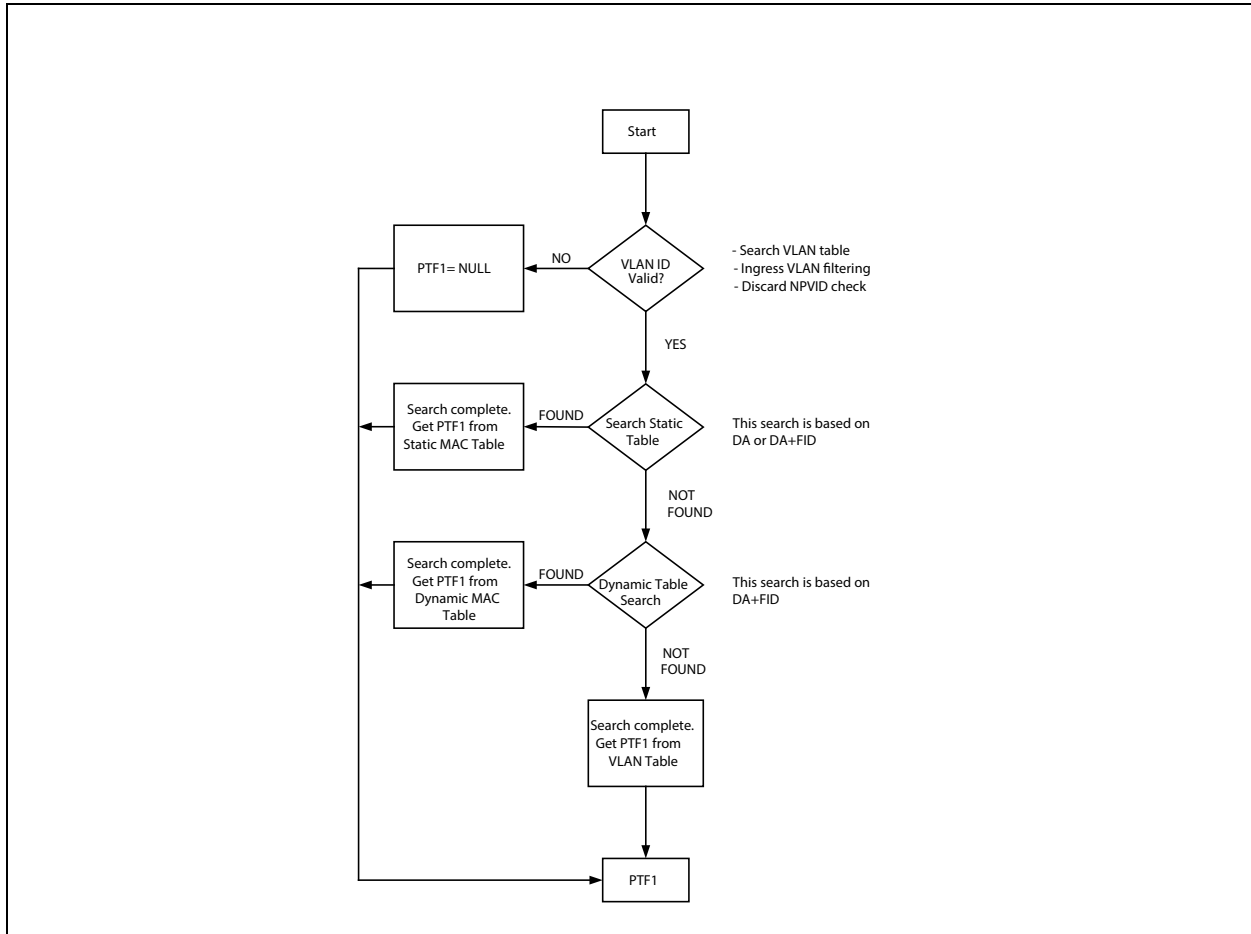

**FIGURE 3-5: DESTINATION ADDRESS RESOLUTION FLOW CHART, STAGE 2**

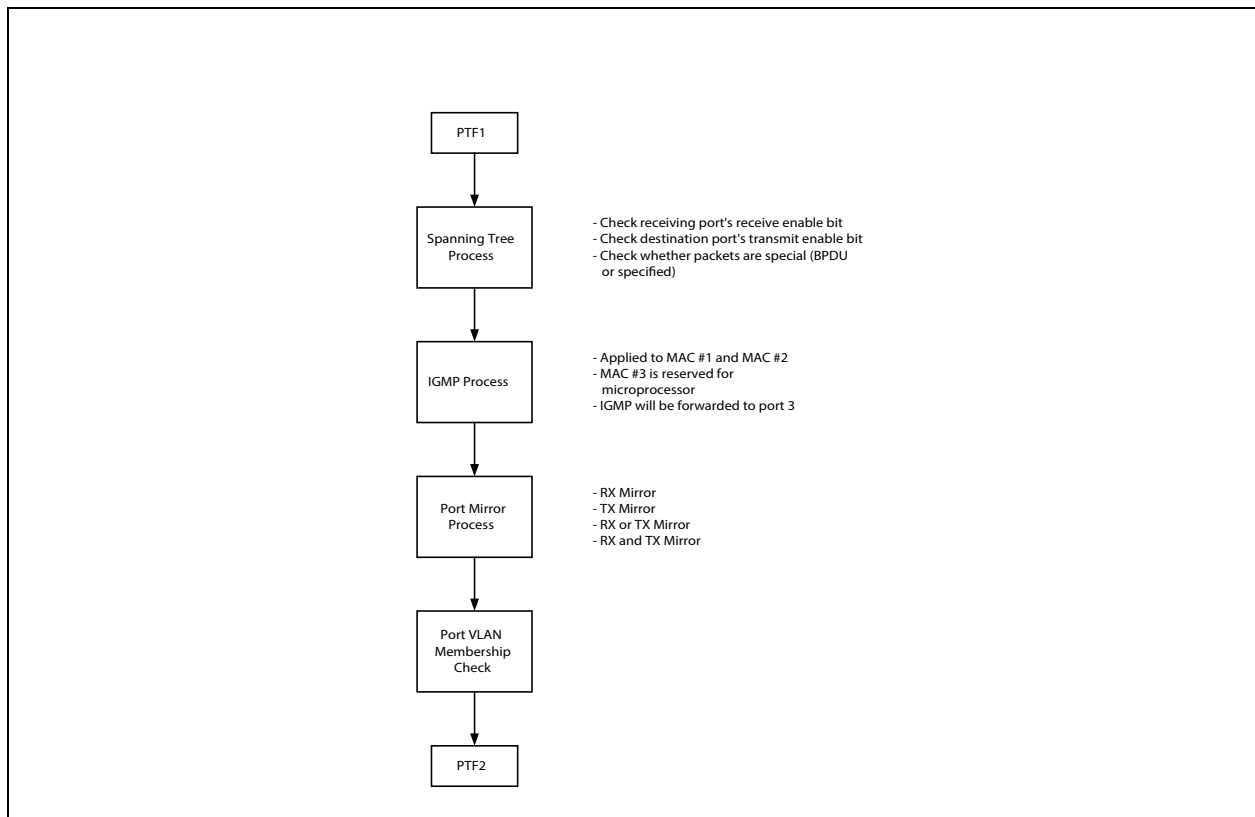

The KSZ8873MLL/FLL/RLL will not forward the following packets:

1. Error packets: These include framing errors, Frame Check Sequence (FCS) errors, alignment errors, and illegal size packet errors.
2. IEEE802.3x PAUSE frames: KSZ8873MLL/FLL/RLL intercepts these packets and performs full-duplex flow control accordingly.
3. "Local" packets: Based on destination address (DA) lookup. If the destination port from the lookup table matches the port from which the packet originated, the packet is defined as local.

### 3.3.6 SWITCHING ENGINE

The KSZ8873MLL/FLL/RLL features a high-performance switching engine to move data to and from the MAC's packet buffers. It operates in store and forward mode, while the efficient switching mechanism reduces overall latency.

The switching engine has a 32 kb internal frame buffer. This buffer pool is shared between all three ports. There are a total of 256 buffers available. Each buffer is sized at 128 bytes.

### 3.3.7 MAC OPERATION

The KSZ8873MLL/FLL/RLL strictly abides by IEEE 802.3 standards to maximize compatibility.

#### 3.3.7.1 Inter Packet Gap (IPG)

If a frame is successfully transmitted, the 96 bits time IPG is measured between the two consecutive MTXEN. If the current packet is experiencing collision, the 96 bits time IPG is measured from MCRS and the next MTXEN.

#### 3.3.7.2 Back-Off Algorithm

The KSZ8873MLL/FLL/RLL implements the IEEE 802.3 standard for the binary exponential back-off algorithm, and optional "aggressive mode" back-off. After 16 collisions, the packet is optionally dropped depending on the switch configuration for register 4 (0x04) bit [3].



# KSZ8873MLL/FLL/RLL

---

---

## 3.3.7.3 Late Collision

If a transmit packet experiences collisions after 512 bit times of the transmission, the packet is dropped.

## 3.3.7.4 Illegal Frames

The KSZ8873MLL/FLL/RLL discards frames less than 64 bytes and can be programmed to accept frames up to 1518 bytes, 1536 bytes, or 1916 bytes. These maximum frame size settings are programmed in register 4 (0x04). Because the KSZ8873MLL/FLL/RLL supports VLAN tags, the maximum sizing is adjusted when these tags are present.

## 3.3.7.5 Full-Duplex Flow Control

The KSZ8873MLL/FLL/RLL supports standard IEEE 802.3x flow control frames on both transmit and receive sides.

On the receive side, if the KSZ8873MLL/FLL/RLL receives a pause control frame, the KSZ8873MLL/FLL/RLL will not transmit the next normal frame until the timer, specified in the pause control frame, expires. If another pause frame is received before the current timer expires, the timer will be updated with the new value in the second pause frame. During this period (while it is flow controlled), only flow control packets from the KSZ8873MLL/FLL/RLL are transmitted.

On the transmit side, the KSZ8873MLL/FLL/RLL has intelligent and efficient ways to determine when to invoke flow control. The flow control is based on availability of the system resources, including available buffers, available transmit queues, and available receive queues.

The KSZ8873MLL/FLL/RLL will flow control a port that has just received a packet if the destination port resource is busy. The KSZ8873MLL/FLL/RLL issues a flow control frame (XOFF), containing the maximum pause time defined by the IEEE 802.3x standard. Once the resource is freed up, the KSZ8873MLL/FLL/RLL sends out the other flow control frame (XON) with zero pause time to turn off the flow control (turn on transmission to the port). A hysteresis feature is provided to prevent the flow control mechanism from being constantly activated and deactivated.

The KSZ8873MLL/FLL/RLL flow controls all ports if the receive queue becomes full.

## 3.3.7.6 Half-Duplex Backpressure

A half-duplex backpressure option (not in IEEE 802.3 standards) is also provided. The activation and deactivation conditions are the same as full-duplex flow control. If backpressure is required, the KSZ8873MLL/FLL/RLL sends preambles to defer the other stations' transmission (carrier sense deference).

To avoid jabber and excessive deference (as defined in the 802.3 standard), after a certain time, the KSZ8873MLL/FLL/RLL discontinues the carrier sense and then raises it again quickly. This short silent time (no carrier sense) prevents other stations from sending out packets thus keeping other stations in a carrier sense deferred state. If the port has packets to send during a backpressure situation, the carrier sense type backpressure is interrupted and those packets are transmitted instead. If there are no additional packets to send, carrier sense type backpressure is reactivated again until switch resources free up. If a collision occurs, the binary exponential back-off algorithm is skipped and carrier sense is generated immediately, thus reducing the chance of further collisions and carrier sense is maintained to prevent packet reception.

To ensure no packet loss in 10BASE-T or 100BASE-TX half-duplex modes, the user must enable the following:

- Aggressive back-off (register 3 (0x03), bit [0])
- No excessive collision drop (register 4 (0x04), bit [3])

Note that these bits are not set as defaults because this is not the IEEE standard.

## 3.3.7.7 Broadcast Storm Protection

The KSZ8873MLL/FLL/RLL has an intelligent option to protect the switch system from receiving too many broadcast packets. As the broadcast packets are forwarded to all ports except the source port, an excessive number of switch resources (bandwidth and available space in transmit queues) may be utilized. The KSZ8873MLL/FLL/RLL has the option to include "multicast packets" for storm control. The broadcast storm rate parameters are programmed globally, and can be enabled or disabled on a per port basis. The rate is based on a 67 ms interval for 100BT and a 500 ms interval for 10BT. At the beginning of each interval, the counter is cleared to zero, and the rate limit mechanism starts to count the number of bytes during the interval. The rate definition is described in register 6 (0x06) and 7 (0x07). The default setting is 0x63 (99 decimal). This is equal to a rate of 1%, calculated as follows:

$148,800 \text{ frames/sec} \times 67 \text{ ms/interval} \times 1\% = 99 \text{ frames/interval (approx.)} = 0x63$

Note: 148,800 frames/sec is based on 64-byte block of packets in 100BASE-TX with 12 bytes of IPG and 8 bytes of preamble between two packets.

### 3.3.7.8 Port Individual MAC Address and Source Port Filtering

The KSZ8873MLL/FLL/RLL provide individual MAC address for port 1 and port 2 respectively. They can be set at register 142-147 and 148-153. With this feature, the CPU connected to the port 3 can receive the packets from two internet subnets which has their own MAC address.

The packet will be filtered if its source address matches the MAC address of port 1 or port 2 when the register 21 and 37 bit 6 is set to 1 respectively. For example, the packet will be dropped after it completes the loop of a ring network.

### 3.3.8 MII INTERFACE OPERATION

The Media Independent Interface (MII) is specified in Clause 22 of the IEEE 802.3u Standard. It provides a common interface between physical layer and MAC layer devices. The MII provided by the KSZ8873MLL/FLL is connected to the device's third MAC. The interface contains two distinct groups of signals: one for transmission and the other for reception. Table 3-4 describes the signals used by the MII bus.

**TABLE 3-4: MII SIGNALS**

PHY Mode Connections		Pin Description	MAC Mode Connections	
External MAC Controller Signals	KSZ8873MLL/FLL PHY Signals		External PHY Signals	KSZ8873MLL/FLL MAC Signals
MTXEN	SMTXEN3	Transmit Enable	MTXEN	SMRXDV3
MTXER	SMTXER3	Transmit Error	MTXER	(NOT USED)
MTXD3	SMTXD33	Transmit Data Bit 3	MTXD3	SMRXD33
MTXD2	SMTXD32	Transmit Data Bit 2	MTXD2	SMRXD32
MTXD1	SMTXD31	Transmit Data Bit 1	MTXD1	SMRXD31
MTXD0	SMTXD30	Transmit Data Bit 0	MTXD0	SMRXD30
MTXC	SMTXC3	Transmit Clock	MTXC	SMRXC3
MCOL	SCOL3	Collision Detection	MCOL	SCOL3
MCRS	SCRS3	Carrier Sense	MCRS	SCRS3
MRXDV	SMRXDV3	Receive Data Valid	MRXDV	SMTXEN3
MRXER	(NOT USED)	Receive Error	MRXER	SMTXER3
MRXD3	SMRXD33	Receive Data Bit 3	MRXD3	SMTXD33
MRXD2	SMRXD32	Receive Data Bit 2	MRXD2	SMTXD32
MRXD1	SMRXD31	Receive Data Bit 1	MRXD1	SMTXD31
MRXD0	SMRXD30	Receive Data Bit 0	MRXD0	SMTXD30
MRXC	SMRXC3	Receive Clock	MRXC	SMTXC3

The MII operates in either PHY mode or MAC mode. The data interface is a nibble wide and runs at ¼ the network bit rate (not encoded). Additional signals on the transmit side indicate when data is valid or when an error occurs during transmission. Similarly, the receive side has signals that convey when the data is valid and without physical layer errors. For half-duplex operation, the SCOL signal indicates if a collision has occurred during transmission.

The KSZ8873MLL/FLL does not provide the MRXER signal for PHY mode operation and the MTXER signal for MAC mode operation. Normally, MRXER indicates a receive error coming from the physical layer device and MTXER indicates a transmit error from the MAC device. Because the switch filters error frames, these MII error signals are not used by the KSZ8873MLL/FLL. So, for PHY mode operation, if the device interfacing with the KSZ8873MLL/FLL has an MRXER input pin, it needs to be tied low. And, for MAC mode operation, if the device interfacing with the KSZ8873MLL/FLL has an MTXER input pin, it also needs to be tied low.

The KSZ8873MLL/FLL provides a bypass feature in the MII PHY mode. Pin SMTXER3/MII\_LINK is used for MII link status. If the host is power down, pin MII\_LINK will go to high. In this case, no new ingress frames from port1 or port 2 will be sent out through port 3, and the frames for port 3 already in packet memory will be flushed out.

### 3.3.9 RMII INTERFACE OPERATION

The Reduced Media Independent Interface (RMII) specifies a low pin count Media Independent Interface (MII). RMII provides a common interface between physical layer and MAC layer devices, and has the following key characteristics:

- Ports 10 Mbps and 100 Mbps data rates.

# KSZ8873MLL/FLL/RLL

- Uses a single 50 MHz clock reference (provided internally or externally).
- Provides independent 2-bit wide (di-bit) transmit and receive data paths.
- Contains two distinct groups of signals: one for transmission and the other for reception

When EN\_REFCKO\_3 is high, KSZ8873RLL will output a 50 MHz in REFCKO\_3. Register 198 bit[3] is used to select internal or external reference clock. Internal reference clock means that the clock for the RMII of KSZ8873RLL will be provided by the KSZ8873RLL internally and the REFCKI\_3 pin is unconnected. For the external reference clock, the clock will provide to KSZ8873RLL via REFCKI\_3.

If the reference clock is not provided by the KSZ8873RLL, this 50 MHz reference clock has to be used in X1 pin instead of the 25 MHz crystal because the clock skew of these two clock sources will impact the RMII timing. The SPIQ clock selection strapping option pin is connected to low to select the 50 MHz input.

If the reference clock is provided by the KSZ8873RLL, set register 54[7]=1 to invert the RMII reference clock to meet the timing specification in the worst cases.

**TABLE 3-5: RMII CLOCK SETTING**

Reg. 198 Bit[3]	Pin 20 SMTXD33/ EN_REFCKO_3 Internal Pull-Up	Pin 39 SPIQ Internal Pull-Up	Clock Source	Note
0	0 (pull down by 1 kΩ)	0 (pull down by 1 kΩ)	External 50 MHz OSC input to SMTXC3/REFCKI_3 and X1 pin directly	EN_REFCKO_3 = 0 to Disable REFCKO_3 for better EMI
0	1	0 (pull down by 1 kΩ)	50 MHz on X1 pin is as clock source. REFCKO_3 Output Is Feedback to REFCKI_3 externally	EN_REFCKO_3 = 1 to Enable REFCKO_3
0	1	1	25 MHz on X1 pin is as clock source. REFCKO_3 Output is connected to REFCKI_3 externally	EN_REFCKO_3 = 1 to Enable REFCKO_3
1	1	0	50 MHz on X1 pin, 50 MHz RMII Clock goes to SMTXC3/ REFCKI_3 internally. REFCKI_3 can be pulled down by a resistor.	EN_REFCKO_3 = 1 to Enable REFCKO_3 and no feedback to REFCKI_3
1	1	1	25 MHz on X1 pin, 50 MHz RMII Clock goes to SMTXC3/ REFCKI_3 internally. REFCKI_3 can be pulled down by a resistor.	EN_REFCKO_3 = 1 to Enable REFCKO_3 and no feedback to REFCKI_3

The RMII provided by the KSZ8873RLL is connected to the device's third MAC. It complies with the RMII Specification. [Table 3-6](#) describes the signals used by the RMII bus. Refer to RMII Specification for full detail on the signal description.

**TABLE 3-6: RMII SIGNAL DESCRIPTION**

RMII Signal Name	Direction (with respect to PHY)	Direction (with respect to MAC)	RMII Signal Description	KSZ8873RLL RMII Signal Direction
REF_CLK	Input	Input or Output	Synchronous 50 MHz clock reference for receive, transmit, and control interface	REFCKI_3 (input)
CRS_DV	Output	Input	Carrier sense/ Receive data valid	SMRXDV3 (output)
RXD1	Output	Input	Receive data bit 1	SMRXD31 (output)
RXD0	Output	Input	Receive data bit 0	SMRXD30 (output)
TX_EN	Input	Output	Transmit enable	SMTXEN3 (input)
TXD1	Input	Output	Transmit data bit 1	SMTXD31 (input)
TXD0	Input	Output	Transmit data bit 0	SMTXD30 (input)

# KSZ8873MLL/FLL/RLL

**TABLE 3-6: RMII SIGNAL DESCRIPTION (CONTINUED)**

RMII Signal Name	Direction (with respect to PHY)	Direction (with respect to MAC)	RMII Signal Description	KSZ8873RLL RMII Signal Direction
RX_ER	Output	Input (not required)	Receive error	(not used)
—	—	—	—	SMTXER3 (input) Connects to RX_ER signal of RMII PHY device

The KSZ8873RLL filters error frames and, thus, does not implement the RX\_ER output signal. To detect error frames from RMII PHY devices, the SMTXER3 input signal of the KSZ8873RLL is connected to the RXER output signal of the RMII PHY device.

Collision detection is implemented in accordance with the RMII Specification.

In RMII mode, tie MII signals SMTXD3[3:2] and SMTXER3 to ground if they are not used.

The KSZ8873RLL RMII can interface with RMII PHY and RMII MAC devices. The latter allows two KSZ8873RLL devices to be connected back-to-back. Table 3-7 shows the KSZ8873RLL RMII pin connections with an external RMII PHY and an external RMII MAC, such as another KSZ8873RLL device.

**TABLE 3-7: RMII SIGNAL CONNECTIONS**

KSZ8873RLL PHY-MAC Connections		Pin Descriptions	KSZ8873RLL MAC-MAC Connections	
External PHY Signals	KSZ8873RLL MAC Signals		KSZ8873RLL MAC Signals	External MAC Signals
REF_CLK	REFCLKI_3	Reference Clock	REFCLKI_3	REF_CLK
TX_EN	SMRXDV3	Carrier sense/ Receive data valid	SMRXDV3	CRS_DV
TXD1	SMRXD31	Receive data bit 1	SMRXD31	RXD1
TXD0	SMRXD30	Receive data bit 0	SMRXD30	RXD0
CRS_DV	SMTXEN3	Transmit enable	SMTXEN3	TX_EN
RXD1	SMTXD31	Transmit data bit 1	SMTXD31	TXD1
RXD0	SMTXD30	Transmit data bit 0	SMTXD30	TXD0
RX_ER	SMTXER3	Receive error	(not used)	(not used)

### 3.3.10 MII MANAGEMENT (MIIM) INTERFACE

The KSZ8873MLL/FLL/RLL supports the IEEE 802.3 MII Management Interface, also known as the Management Data Input/Output (MDIO) Interface. This interface allows upper-layer devices to monitor and control the states of the KSZ8873MLL/FLL/RLL. An external device with MDC/MDIO capability is used to read the PHY status or configure the PHY settings. Further detail on the MIIM interface is found in Clause 22.2.4.5 of the IEEE 802.3u Specification and refer to 802.3 section 22.3.4 for the timing.

The MIIM interface consists of the following:

- A physical connection that incorporates the data line (SDA\_MDIO) and the clock line (SCL\_MDC).
- A specific protocol that operates across the aforementioned physical connection that allows an external controller to communicate with the KSZ8873MLL/FLL/RLL device.
- Access to a set of eight 16-bit registers, consisting of six standard MIIM registers [0:5] and two custom MIIM registers [29, 31].

The MIIM Interface can operate up to a maximum clock speed of 5 MHz.

Table 3-8 depicts the MII Management Interface frame format.

# KSZ8873MLL/FLL/RLL

**TABLE 3-8: MII MANAGEMENT FRAME FORMAT**

	Preamble	Start of Frame	Read/Write OP Code	PHY Address Bits[4:0]	REG Address Bits[4:0]	TA	Data Bits[15:0]	Idle
<b>Read</b>	32 1's	01	10	AAAAA	RRRRR	Z0	DDDDDDDD_DDDDDDDD	Z
<b>Write</b>	32 1's	01	01	AAAAA	RRRRR	10	DDDDDDDD_DDDDDDDD	Z

## 3.3.11 SERIAL MANAGEMENT INTERFACE (SMI)

The SMI is the KSZ8873MLL/FLL/RLL non-standard MIIM interface that provides access to all KSZ8873MLL/FLL/RLL configuration registers. This interface allows an external device to completely monitor and control the states of the KSZ8873MLL/FLL/RLL.

The SMI interface consists of the following:

- A physical connection that incorporates the data line (SDA\_MDIO) and the clock line (SCL\_MDC).
- A specific protocol that operates across the aforementioned physical connection that allows an external controller to communicate with the KSZ8873MLL/FLL/RLL device.
- Access to all KSZ8873MLL/FLL/RLL configuration registers. Register access includes the Global, Port and Advanced Control Registers 0-198 (0x00 – 0xC6), and indirect access to the standard MIIM registers [0:5] and custom MIIM registers [29, 31].

Table 3-9 depicts the SMI frame format.

**TABLE 3-9: SERIAL MANAGEMENT INTERFACE (SMI) FRAME FORMAT**

	Preamble	Start of Frame	Read/Write OP Code	PHY Address Bits[4:0]	REG Address Bits[4:0]	TA	Data Bits[15:0]	Idle
<b>Read</b>	32 1's	01	00	1xRRR	RRRRR	Z0	0000_0000_DDDD_DDDD	Z
<b>Write</b>	32 1's	01	00	0xRRR	RRRRR	10	xxxx_xxxx_DDDD_DDDD	Z

SMI register read access is selected when OP Code is set to "00" and bit 4 of the PHY address is set to '1'. SMI register write access is selected when OP Code is set to "00" and bit 4 of the PHY address is set to '0'. PHY address bit[3] is undefined for SMI register access, and hence can be set to either '0' or '1' in read/write operations.

To access the KSZ8873MLL/FLL/RLL registers 0-196 (0x00 – 0xC6), the following applies:

- PHYAD[2:0] and REGAD[4:0] are concatenated to form the 8-bit address; that is, {PHYAD[2:0], REGAD[4:0]} = bits [7:0] of the 8-bit address.
- TA bits [1:0] are 'Z0' means the processor MDIO pin is changed to input Hi-Z from output mode and the followed '0' is the read response from device.
- TA bits [1:0] are set to '10' when write registers.
- Registers are 8 data bits wide.
  - For read operation, data bits [15:8] are read back as 0's.
  - For write operation, data bits [15:8] are not defined, and hence can be set to either '0' or '1'.

SMI register access is the same as the MIIM register access, except for the register access requirements presented in this section.

## 3.4 Advanced Switch Functions

### 3.4.1 BYPASS MODE

The KSZ8873MLL/FLL/RLL also offers a bypass mode that enables system-level power saving. When the CPU (connected to Port 3) enters a power saving mode of power down or sleeping mode, the CPU can control pin 27 SMTXER3/ MII\_LINK\_3, which can be tied high so that the KSZ8873MLL/FLL/RLL detects this change and automatically switches to the bypass mode. In this mode, the switch function between Port 1 and Port 2 is sustained. The packets with DA to Port 3 will be dropped and will bypass the internal buffer memory, making the buffer memory more efficient for the data transfer between Port 1 and Port 2.

## 3.4.2 IEEE 802.1Q VLAN SUPPORT

The KSZ8873MLL/FLL/RLL supports 16 active VLANs out of the 4096 possible VLANs specified in the IEEE 802.1Q specification. KSZ8873MLL/FLL/RLL provides a 16-entries VLAN table that converts the 12-bits VLAN ID (VID) to the 4-bits Filter ID (FID) for address lookup. If a non-tagged or null-VID-tagged packet is received, the ingress port default VID is used for lookup. In VLAN mode, the lookup process starts with VLAN table lookup to determine whether the VID is valid. If the VID is not valid, the packet is dropped and its address is not learned. If the VID is valid, the FID is retrieved for further lookup. The FID + Destination Address (FID+DA) are used to determine the destination port. The FID + Source Address (FID+SA) are used for address learning.

**TABLE 3-10: FID+DA LOOKUP IN VLAN MODE**

DA Found in Static MAC Table?	Use FID Flag?	FID Match?	FID+DA Found in Dynamic MAC Table?	Action
No	Don't care	Don't care	No	Broadcast to the membership ports defined in the VLAN Table bits [18:16]
No	Don't care	Don't care	Yes	Send to the destination port defined in the Dynamic MAC Address Table bits [53:52]
Yes	0	Don't care	Don't care	Send to the destination port(s) defined in the Static MAC Address Table bits [50:48]
Yes	1	No	No	Broadcast to the membership ports defined in the VLAN Table bits [18:16]
Yes	1	No	Yes	Send to the destination port defined in the Dynamic MAC Address Table bits [53:52]
Yes	1	Yes	Don't care	Send to the destination port(s) defined in the Static MAC Address Table bits [50:48]

**TABLE 3-11: FID+SA LOOKUP IN VLAN MODE**

FID+SA Found in Dynamic MAC Table?	Action
No	Learn and add FID+SA to the Dynamic MAC Address Table
Yes	Update time stamp

Advanced VLAN features, such as “Ingress VLAN filtering” and “Discard Non PVID packets” are also supported by the KSZ8873MLL/FLL/RLL. These features can be set on a per port basis, and are defined in registers 18, 34, and 50 for ports 1, 2 and 3, respectively.

## 3.4.3 QOS PRIORITY SUPPORT

The KSZ8873MLL/FLL/RLL provides Quality of Service (QoS) for applications such as VoIP and video conferencing. Offering four priority queues per port, the per-port transmit queue can be split into four priority queues: Queue 3 is the highest priority queue and Queue 0 is the lowest priority queue. Bit [0] of registers 16, 32, and 48 is used to enable split transmit queues for ports 1, 2, and 3, respectively. If a port's transmit queue is not split, high priority and low priority packets have equal priority in the transmit queue.

There is an additional option to either always deliver high priority packets first or use weighted fair queuing for the four priority queues. This global option is set and explained in bit [3] of register 5.

## 3.4.4 PORT-BASED PRIORITY

With port-based priority, each ingress port is individually classified as a high priority receiving port. All packets received at the high priority receiving port are marked as high priority and are sent to the high-priority transmit queue if the corresponding transmit queue is split. Bits [4:3] of registers 16, 32, and 48 are used to enable port-based priority for ports 1, 2, and 3, respectively.

# KSZ8873MLL/FLL/RLL

## 3.4.5 802.1P-BASED PRIORITY

For 802.1p-based priority, the KSZ8873MLL/FLL/RLL examines the ingress (incoming) packets to determine whether they are tagged. If tagged, the 3-bit priority field in the VLAN tag is retrieved and compared against the “priority mapping” value, as specified by the registers 12 and 13. The “priority mapping” value is programmable.

Figure 3-6 illustrates how the 802.1p priority field is embedded in the 802.1Q VLAN tag.

**FIGURE 3-6: 802.1P PRIORITY FIELD FORMAT**

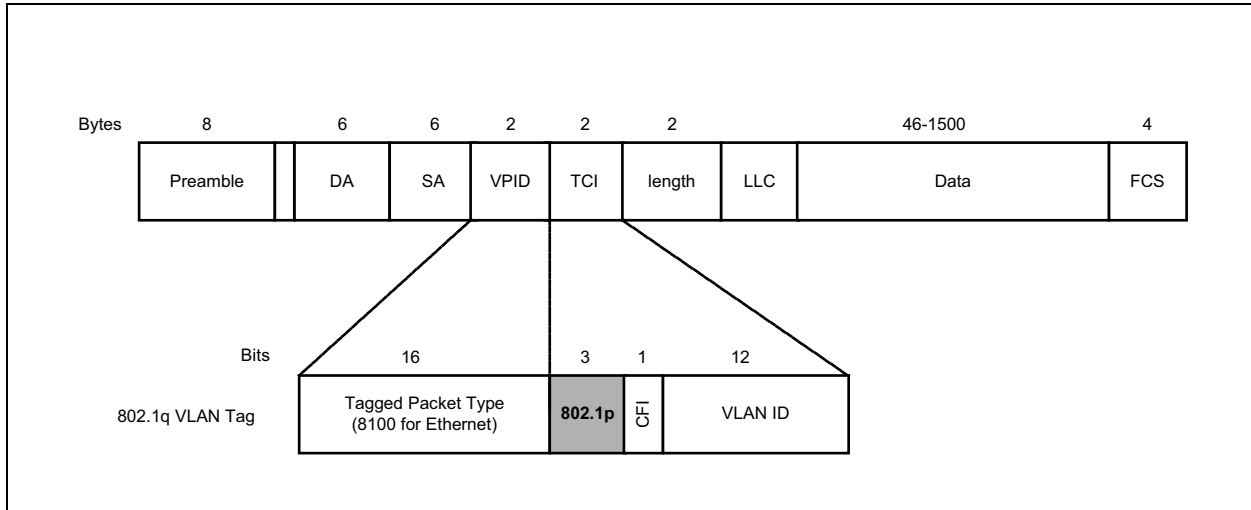

802.1p-based priority is enabled by bit [5] of registers 16, 32, and 48 for ports 1, 2, and 3, respectively.

The KSZ8873MLL/FLL/RLL provides the option to insert or remove the priority tagged frame's header at each individual egress port. This header, consisting of the 2 bytes VLAN Protocol ID (VPID) and the 2-byte Tag Control Information field (TCI), is also referred to as the IEEE 802.1Q VLAN tag.

Tag Insertion is enabled by bit [2] of the port registers control 0 and the register 194 to select which source port (ingress port) PVID can be inserted on the egress port for ports 1, 2, and 3, respectively. At the egress port, untagged packets are tagged with the ingress port's default tag. The default tags are programmed in register sets {19,20}, {35,36}, and {51,52} for ports 1, 2, and 3, respectively, and the source port VID has to be inserted at selected egress ports by bit[5:0] of register 194. The KSZ8873MLL/FLL/RLL will not add tags to already tagged packets.

Tag Removal is enabled by bit [1] of registers 16, 32, and 48 for ports 1, 2, and 3, respectively. At the egress port, tagged packets will have their 802.1Q VLAN Tags removed. The KSZ8873MLL/FLL/RLL will not modify untagged packets.

The CRC is recalculated for both tag insertion and tag removal.

802.1p Priority Field Re-mapping is a QoS feature that allows the KSZ8873MLL/FLL/RLL to set the “User Priority Ceiling” at any ingress port. If the ingress packet's priority field has a higher priority value than the default tag's priority field of the ingress port, the packet's priority field is replaced with the default tag's priority field.

## 3.4.6 DIFFSERV-BASED PRIORITY

DiffServ-based priority uses the ToS registers (registers 96 to 111) in the Advanced Control Registers section. The ToS priority control registers implement a fully decoded, 64-bit Differentiated Services Code Point (DSCP) register to determine packet priority from the 6-bit ToS field in the IP header. When the most significant 6 bits of the ToS field are fully decoded, the resultant of the 64 possibilities is compared with the corresponding bits in the DSCP register to determine priority.

## 3.5 Spanning Tree Support

To support spanning tree, port 3 is designated as the processor port.

The other ports (port 1 and port 2) can be configured in one of the five spanning tree states via “transmit enable”, “receive enable” and “learning disable” register settings in registers 18 and 34 for ports 1 and 2, respectively. The following table shows the port setting and software actions taken for each of the five spanning tree states.

**TABLE 3-12: SPANNING TREE STATES**

Disable State	Port Setting	Software Action
The port should not forward or receive any packets. Learning is disabled.	"transmit enable = 0, receive enable = 0, learning disable =1"	The processor should not send any packets to the port. The switch may still send specific packets to the processor (packets that match some entries in the "static MAC table" with "overriding bit" set) and the processor should discard those packets. Address learning is disabled on the port in this state.
Blocking State	Port Setting	Software Action
Only packets to the processor are forwarded. Learning is disabled.	"transmit enable = 0, receive enable = 0, learning disable =1"	The processor should not send any packets to the port(s) in this state. The processor should program the "Static MAC table" with the entries that it needs to receive (for example, BPDU packets). The "overriding" bit should also be set so that the switch will forward those specific packets to the processor. Address learning is disabled on the port in this state.
Listening State	Port Setting	Software Action
Only packets to and from the processor are forwarded. Learning is disabled.	"transmit enable = 0, receive enable = 0, learning disable =1"	The processor should program the "Static MAC table" with the entries that it needs to receive (for example, BPDU packets). The "overriding" bit should be set so that the switch will forward those specific packets to the processor. The processor may send packets to the port(s) in this state. See "Tail Tagging Mode" for details. Address learning is disabled on the port in this state.
Learning State	Port Setting	Software Action
Only packets to and from the processor are forwarded. Learning is enabled.	"transmit enable = 0, receive enable = 0, learning disable = 0"	The processor should program the "Static MAC table" with the entries that it needs to receive (for example, BPDU packets). The "overriding" bit should be set so that the switch will forward those specific packets to the processor. The processor may send packets to the port(s) in this state. See "Tail Tagging Mode" for details. Address learning is enabled on the port in this state.
Forwarding State	Port Setting	Software Action
Packets are forwarded and received normally. Learning is enabled.	"transmit enable = 1, receive enable = 1, learning disable = 0"	The processor programs the "Static MAC table" with the entries that it needs to receive (for example, BPDU packets). The "overriding" bit is set so that the switch forwards those specific packets to the processor. The processor can send packets to the port(s) in this state. See "Tail Tagging Mode" for details. Address learning is enabled on the port in this state.

### 3.6 Rapid Spanning Tree Support

There are three operational states of the Discarding, Learning, and Forwarding assigned to each port for RSTP:

Discarding ports do not participate in the active topology and do not learn MAC addresses.

Discarding state: the state includes three states of the disable, blocking and listening of STP.

Port setting: "transmit enable = 0, receive enable = 0, learning disable = 1."

Software action: the processor should not send any packets to the port. The switch may still send specific packets to the processor (packets that match some entries in the static table with "overriding bit" set) and the processor should discard those packets. When disable the port's learning capability (learning disable='1'), set the register 2 bit 5 and bit 4 will flush rapidly the port related entries in the dynamic MAC table and static MAC table.

Note: processor is connected to port 3 via MII interface. Address learning is disabled on the port in this state.

Ports in Learning states learn MAC addresses, but do not forward user traffic.



# KSZ8873MLL/FLL/RLL

Learning state: only packets to and from the processor are forwarded. Learning is enabled.

Port setting: “transmit enable = 0, receive enable = 0, learning disable = 0.”

Software action: The processor should program the static MAC table with the entries that it needs to receive (e.g., BPDU packets). The “overriding” bit should be set so that the switch will forward those specific packets to the processor. The processor may send packets to the port(s) in this state, see “Tail Tagging Mode” section for details. Address learning is enabled on the port in this state.

Ports in Forwarding states fully participate in both data forwarding and MAC learning.

Forwarding state: packets are forwarded and received normally. Learning is enabled.

Port setting: “transmit enable = 1, receive enable = 1, learning disable = 0.”

Software action: The processor should program the static MAC table with the entries that it needs to receive (e.g., BPDU packets). The “overriding” bit should be set so that the switch will forward those specific packets to the processor. The processor may send packets to the port(s) in this state, see “Tail Tagging Mode” section for details. Address learning is enabled on the port in this state.

RSTP uses only one type of BPDU called RSTP BPDUs. They are similar to STP Configuration BPDUs with the exception of a type field set to “version 2” for RSTP and “version 0” for STP, and a flag field carrying additional information.

## 3.7 Tail Tagging Mode

The Tail Tag is only seen and used by the port 3 interface, which should be connected to a processor. It is an effective way to retrieve the ingress port information for spanning tree protocol IGMP snooping and other applications. The Bit 1 and bit 0 in the one byte tail tagging is used to indicate the source/destination port in port 3. Bit 3 and bit 2 are used for the priority setting of the ingress frame in port 3. Other bits are not used. The Tail Tag feature is enable by setting register 3 bit 6.

**FIGURE 3-7: TAIL TAG FRAME FORMAT**

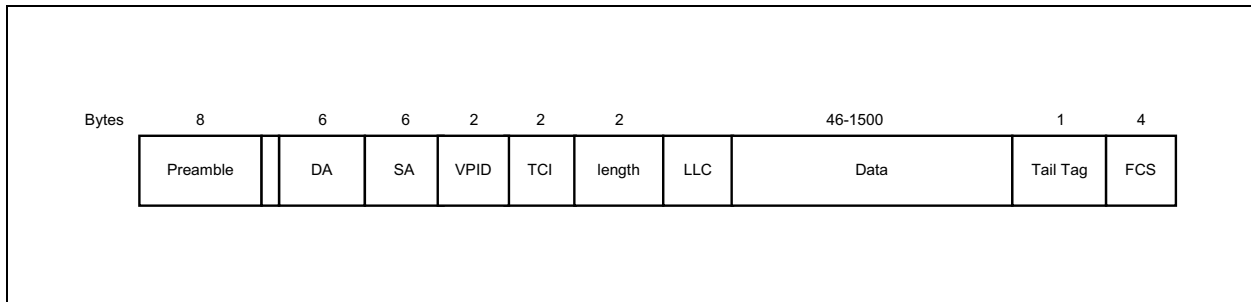

**TABLE 3-13: TAIL TAG RULES**

Ingress to Port 3 (Host to KSZ8873)	
<b>Bit [1,0]</b>	<b>Destination Port</b>
0,0	Normal (address lookup)
0,1	Port 1
1,0	Port 2
1,1	Port 1 and 2
<b>Bit [3,2]</b>	<b>Frame Priority</b>
0,0	Priority 0
0,1	Priority 1
1,0	Priority 2
1,1	Priority 3
Egress from Port 3 (KSZ8873 to Host)	
<b>Bit [0]</b>	<b>Source Port</b>
0	Port 1
1	Port 2

## 3.8 IGMP Support

For Internet Group Management Protocol (IGMP) support in layer 2, the KSZ8873MLL/FLL/RLL provides two components: IGMP snooping and IGMP send-back to the subscribed port.

### 3.8.1 IGMP SNOOPING

The KSZ8873MLL/FLL/RLL traps IGMP packets and forwards them only to the processor (port 3). The IGMP packets are identified as IP packets (either Ethernet IP packets, or IEEE 802.3 SNAP IP packets) with IP version = 0x4 and protocol version number = 0x2.

### 3.8.2 IGMP SEND-BACK TO THE SUBSCRIBED PORT

Once the host responds the received IGMP packet, the host should know the original IGMP ingress port and send back the IGMP packet to this port only, otherwise this IGMP packet will be broadcasted to all ports to downgrade the performance.

Enable the tail tag mode, the host will know the IGMP packet received port from tail tag bits [0] and can send back the response IGMP packet to this subscribed port by setting the bits [1,0] in the tail tag. Enable "Tail tag mode" by setting Register 3 bit 6. The tail tag will be removed automatically when the IGMP packet is sent out from the subscribed port.

## 3.9 Port Mirroring Support

KSZ8873MLL/FLL/RLL supports "Port Mirroring" comprehensively as:

- "Receive only" mirror on a port
  - All the packets received on the port are mirrored on the sniffer port. For example, port 1 is programmed to be "receive sniff" and port 3 is programmed to be the "sniffer port". A packet received on port 1 is destined to port 2 after the internal lookup. The KSZ8873MLL/FLL/RLL forwards the packet to both port 2 and port 3. The KSZ8873MLL/FLL/RLL can optionally even forward "bad" received packets to the "sniffer port".
- "Transmit only" mirror on a port
  - All the packets transmitted on the port are mirrored on the sniffer port. For example, port 1 is programmed to be "transmit sniff" and port 3 is programmed to be the "sniffer port". A packet received on port 2 is destined to port 1 after the internal lookup. The KSZ8873MLL/FLL/RLL forwards the packet to both port 1 and port 3.
- "Receive and transmit" mirror on two ports
  - All the packets received on port A and transmitted on port B are mirrored on the sniffer port. To turn on the "AND" feature, set register 5 bit [0] to '1'. For example, port 1 is programmed to be "receive sniff", port 2 is programmed to be "transmit sniff", and port 3 is programmed to be the "sniffer port". A packet received on port 1 is destined to port 2 after the internal lookup. The KSZ8873MLL/FLL/RLL forwards the packet to both port 2 and port 3.

Multiple ports can be selected as "receive sniff" or "transmit sniff". In addition, any port can be selected as the "sniffer port". All these per port features can be selected through registers 17, 33, and 49 for ports 1, 2, and 3, respectively.

## 3.10 Rate Limiting Support

The KSZ8873MLL/FLL/RLL provides a fine resolution hardware rate limiting from 64 kbps to 99 Mbps. The rate step is 64 kbps when the rate range is from 64 kbps to 960 kbps and 1 Mbps for 1 Mbps to 100 Mbps (100BT) or to 10 Mbps (10BT) (refer to Data Rate Limit Table). The rate limit is independently on the "receive side" and on the "transmit side" on a per port basis. For 10BASE-T, a rate setting above 10 Mbps means the rate is not limited. On the receive side, the data receive rate for each priority at each port can be limited by setting up Ingress Rate Control Registers. On the transmit side, the data transmit rate for each priority queue at each port can be limited by setting up Egress Rate Control Registers. The size of each frame has options to include minimum IFG (Inter Frame Gap) or Preamble byte, in addition to the data field (from packet DA to FCS).

For ingress rate limiting, KSZ8873MLL/FLL/RLL provides options to selectively choose frames from all types, multicast, broadcast, and flooded unicast frames. The KSZ8873MLL/FLL/RLL counts the data rate from those selected type of frames. Packets are dropped at the ingress port when the data rate exceeds the specified rate limit.

For egress rate limiting, the Leaky Bucket algorithm is applied to each output priority queue for shaping output traffic. Inter frame gap is stretched on a per frame base to generate smooth, non-burst egress traffic. The throughput of each output priority queue is limited by the egress rate specified.

# KSZ8873MLL/FLL/RLL

If any egress queue receives more traffic than the specified egress rate throughput, packets may be accumulated in the output queue and packet memory. After the memory of the queue or the port is used up, packet dropping or flow control will be triggered. As a result of congestion, the actual egress rate may be dominated by flow control/dropping at the ingress end, and may be therefore slightly less than the specified egress rate.

To reduce congestion, it is a good practice to make sure the egress bandwidth exceeds the ingress bandwidth.

## 3.11 Unicast MAC Address Filtering

The unicast MAC address filtering function works in conjunction with the static MAC address table. First, the static MAC address table is used to assign a dedicated MAC address to a specific port. If a unicast MAC address is not recorded in the static table, it is also not learned in the dynamic MAC table. The KSZ8873MLL/FLL/RLL is then configured with the option to either filter or forward unicast packets for an unknown MAC address. This option is enabled and configured in register 14.

This function is useful in preventing the broadcast of unicast packets that could degrade the quality of the port in applications such as voice over Internet Protocol (VoIP).

## 3.12 Configuration Interface

The KSZ8873MLL/FLL/RLL can operate as both a managed switch and an unmanaged switch.

In unmanaged mode, the KSZ8873MLL/FLL/RLL is typically programmed using an EEPROM. If no EEPROM is present, the KSZ8873MLL/FLL/RLL is configured using its default register settings. Some default settings are configured via strap-in pin options. The strap-in pins are indicated in the “Pin Description and I/O Assignment” table.

### 3.12.1 I<sup>2</sup>C MASTER SERIAL BUS CONFIGURATION

With an additional I<sup>2</sup>C (“2-wire”) EEPROM, the KSZ8873MLL/FLL/RLL can perform more advanced switch features like “broadcast storm protection” and “rate control” without the need of an external processor.

For KSZ8873MLL/FLL/RLL I<sup>2</sup>C Master configuration, the EEPROM stores the configuration data for register 0 to register 120 (as defined in the KSZ8873MLL/FLL/RLL register map) with the exception of the “Read Only” status registers. After the de-assertion of reset, the KSZ8873MLL/FLL/RLL sequentially reads in the configuration data for all control registers, starting from register 0.

**FIGURE 3-8: EEPROM CONFIGURATION TIMING DIAGRAM**

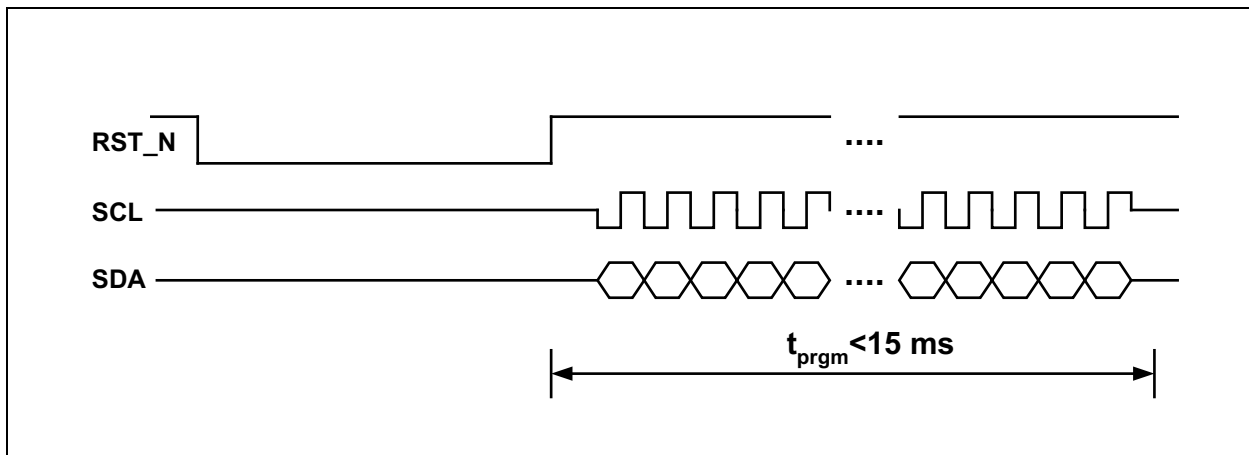

The following is a sample procedure for programming the KSZ8873MLL/FLL/RLL with a pre-configured EEPROM:

1. Connect the KSZ8873MLL/FLL/RLL to the EEPROM by joining the SCL and SDA signals of the respective devices.
2. Enable I<sup>2</sup>C master mode by setting the KSZ8873MLL/FLL/RLL strap-in pins, P2LED[1:0] to “00”.
3. Check to ensure that the KSZ8873MLL/FLL/RLL reset signal input, RSTN, is properly connected to the external reset source at the board level.
4. Program the desired configuration data into the EEPROM.
5. Place the EEPROM on the board and power up the board.

6. Assert an active-low reset to the RSTN pin of the KSZ8873MLL/FLL/RLL. After reset is de-asserted, the KSZ8873MLL/FLL/RLL begins reading the configuration data from the EEPROM. The KSZ8873MLL/FLL/RLL checks that the first byte read from the EEPROM is "88". If this value is correct, EEPROM configuration continues. If not, EEPROM configuration access is denied and all other data sent from the EEPROM is ignored by the KSZ8873MLL/FLL/RLL.

For proper operation, ensure that the KSZ8873MLL/FLL/RLL PWRDN input signal is not asserted during the reset operation. The PWRDN input is active-low.

### 3.12.2 I<sup>2</sup>C SLAVE SERIAL BUS CONFIGURATION

In managed mode, the KSZ8873MLL/FLL/RLL can be configured as an I<sup>2</sup>C slave device. In this mode, an I<sup>2</sup>C master device (external controller/CPU) has complete programming access to the KSZ8873MLL/FLL/RLL's 198 registers. Programming access includes the Global Registers, Port Registers, Advanced Control Registers and indirect access to the "Static MAC Table", "VLAN Table", "Dynamic MAC Table," and "MIB Counters." The tables and counters are indirectly accessed via registers 121 to 131.

In I<sup>2</sup>C slave mode, the KSZ8873MLL/FLL/RLL operates like other I<sup>2</sup>C slave devices. Addressing the KSZ8873MLL/FLL/RLL's 8-bit registers is similar to addressing the Microchip AT24C02 EEPROM's memory locations. Details of I<sup>2</sup>C read/write operations and related timing information can be found in the AT24C02 data sheet.

Two fixed 8-bit device addresses are used to address the KSZ8873MLL/FLL/RLL in I<sup>2</sup>C slave mode. One is for read; the other is for write. The addresses are as follow:

- 1011\_1111 <read>
- 1011\_1110 <write>

The following is a sample procedure for programming the KSZ8873MLL/FLL/RLL using the I<sup>2</sup>C slave serial bus:

1. Enable I<sup>2</sup>C slave mode by setting the KSZ8873MLL/FLL/RLL strap-in pins P2LED[1:0] to "01".
2. Power up the board and assert reset to the KSZ8873MLL/FLL/RLL. Configure the desired register settings in the KSZ8873MLL/FLL/RLL, using the I<sup>2</sup>C write operation.
3. Read back and verify the register settings in the KSZ8873MLL/FLL/RLL, using the I<sup>2</sup>C read operation.

Some of the configuration settings, such as "Aging Enable", "Auto Negotiation Enable", "Force Speed" and "Power down" can be programmed after the switch has been started.

### 3.12.3 SPI SLAVE SERIAL BUS CONFIGURATION

In managed mode, the KSZ8873MLL/FLL/RLL can be configured as a SPI slave device. In this mode, a SPI master device (external controller/CPU) has complete programming access to the KSZ8873MLL/FLL/RLL's 198 registers. Programming access includes the Global Registers, Port Registers, Advanced Control Registers, and indirect access to the "Static MAC Table", "VLAN Table", "Dynamic MAC Table," and "MIB Counters". The tables and counters are indirectly accessed via registers 121 to 131.

The KSZ8873MLL/FLL/RLL supports two standard SPI commands: '0000\_0011' for data read and '0000\_0010' for data write. SPI multiple read and multiple write are also supported by the KSZ8873MLL/FLL/RLL to expedite register read back and register configuration, respectively.

SPI multiple read is initiated when the master device continues to drive the KSZ8873MLL/FLL/RLL SPISN input pin (SPI Slave Select signal) low after a byte (a register) is read. The KSZ8873MLL/FLL/RLL internal address counter increments automatically to the next byte (next register) after the read. The next byte at the next register address is shifted out onto the KSZ8873MLL/FLL/RLL SPIQ output pin. SPI multiple read continues until the SPI master device terminates it by de-asserting the SPISN signal to the KSZ8873MLL/FLL/RLL.

Similarly, SPI multiple write is initiated when the master device continues to drive the KSZ8873MLL/FLL/RLL SPISN input pin low after a byte (a register) is written. The KSZ8873MLL/FLL/RLL internal address counter increments automatically to the next byte (next register) after the write. The next byte that is sent from the master device to the KSZ8873MLL/FLL/RLL SDA input pin is written to the next register address. SPI multiple write continues until the SPI master device terminates it by de-asserting the SPISN signal to the KSZ8873MLL/FLL/RLL.

For both SPI multiple read and multiple write, the KSZ8873MLL/FLL/RLL internal address counter wraps back to register address zero once the highest register address is reached. This feature allows all 198 KSZ8873MLL/FLL/RLL registers to be read, or written with a single SPI command from any initial register address.

The KSZ8873MLL/FLL/RLL is capable of supporting an SPI bus.

The following is a sample procedure for programming the KSZ8873MLL/FLL/RLL using the SPI bus:

# KSZ8873MLL/FLL/RLL

1. At the board level, connect the KSZ8873MLL/FLL/RLL pins as follows:

**TABLE 3-14: SPI CONNECTIONS**

Pin Number	Signal Name	External Processor Signal Description
40	SPISN	SPI Slave Select
42	SCL (SPIC)	SPI Clock
43	SDA (SPID)	SPI Data (Master output; Slave input)
39	SPIQ	SPI Data (Master input; Slave output)

2. Enable SPI slave mode by setting the KSZ8873MLL/FLL/RLL strap-in pins P2LED[1:0] to “10”.
3. Power up the board and assert reset to the KSZ8873MLL/FLL/RLL.
4. Configure the desired register settings in the KSZ8873MLL/FLL/RLL, using the SPI write or multiple write command.
5. Read back and verify the register settings in the KSZ8873MLL/FLL/RLL, using the SPI read or multiple read command.

Some of the configuration settings, such as “Aging Enable,” “Auto Negotiation Enable,” “Force Speed,” and “Power Down” can be programmed after the switch has been started.

The following four figures illustrate the SPI data cycles for “Write,” “Read,” “Multiple Write,” and “Multiple Read.” The read data is registered out of SPIQ on the falling edge of SPIC, and the data input on SPID is registered on the rising edge of SPIC.

**FIGURE 3-9: SPI WRITE DATA CYCLE**

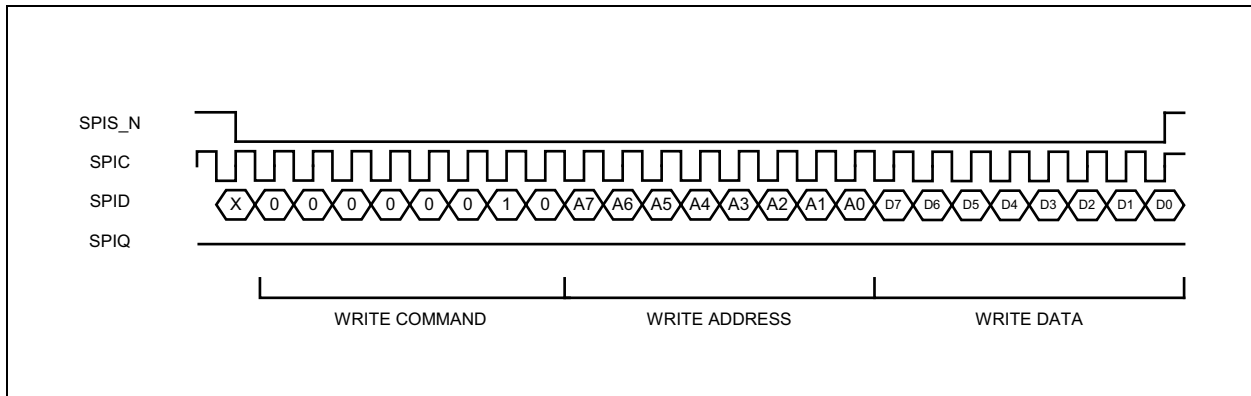

**FIGURE 3-10: SPI READ DATA CYCLE**

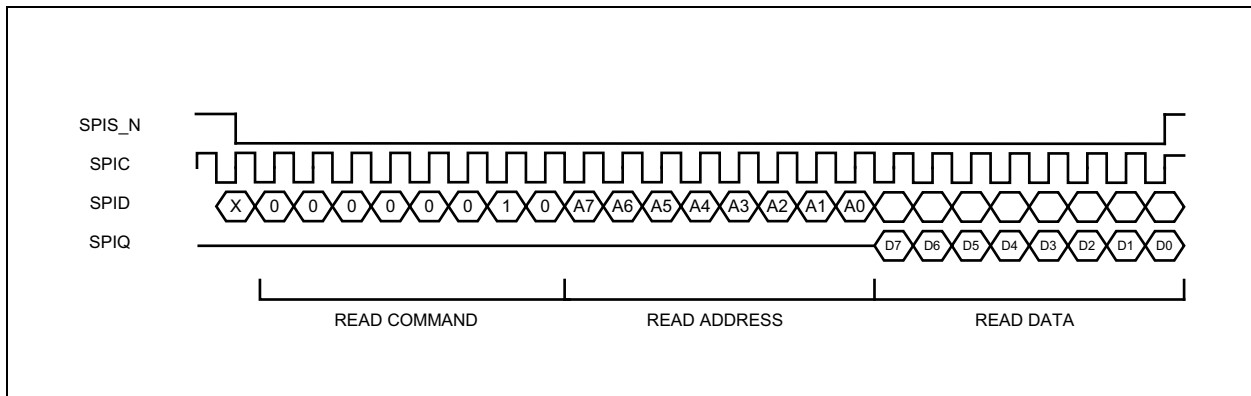

**FIGURE 3-11: SPI MULTIPLE WRITE**

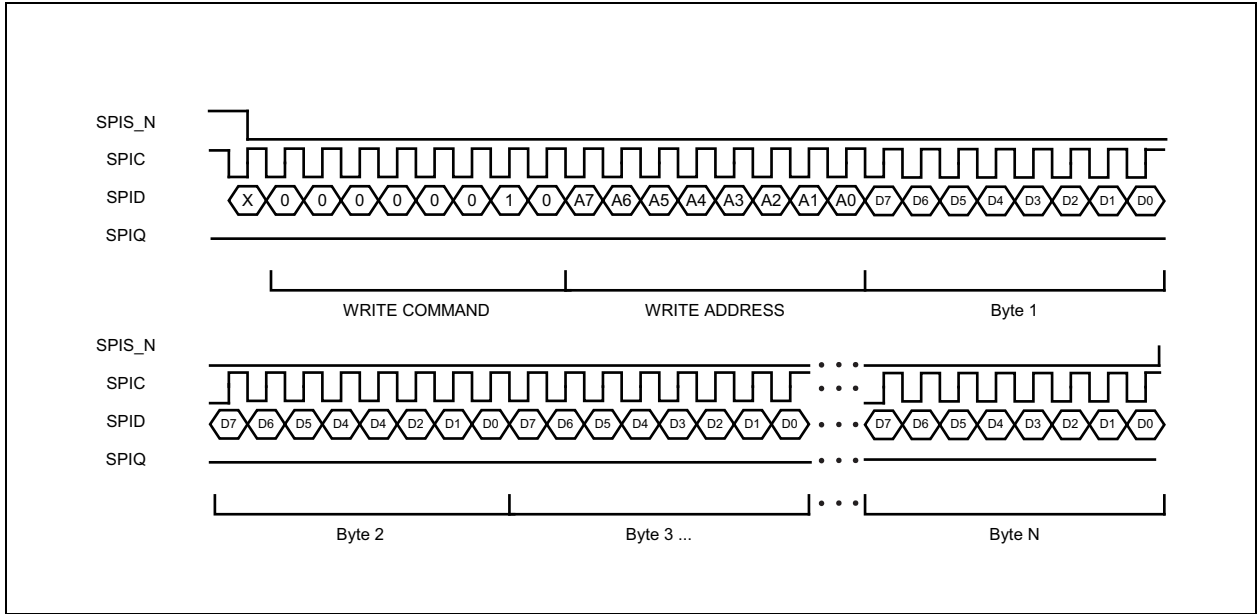

**FIGURE 3-12: SPI MULTIPLE READ**

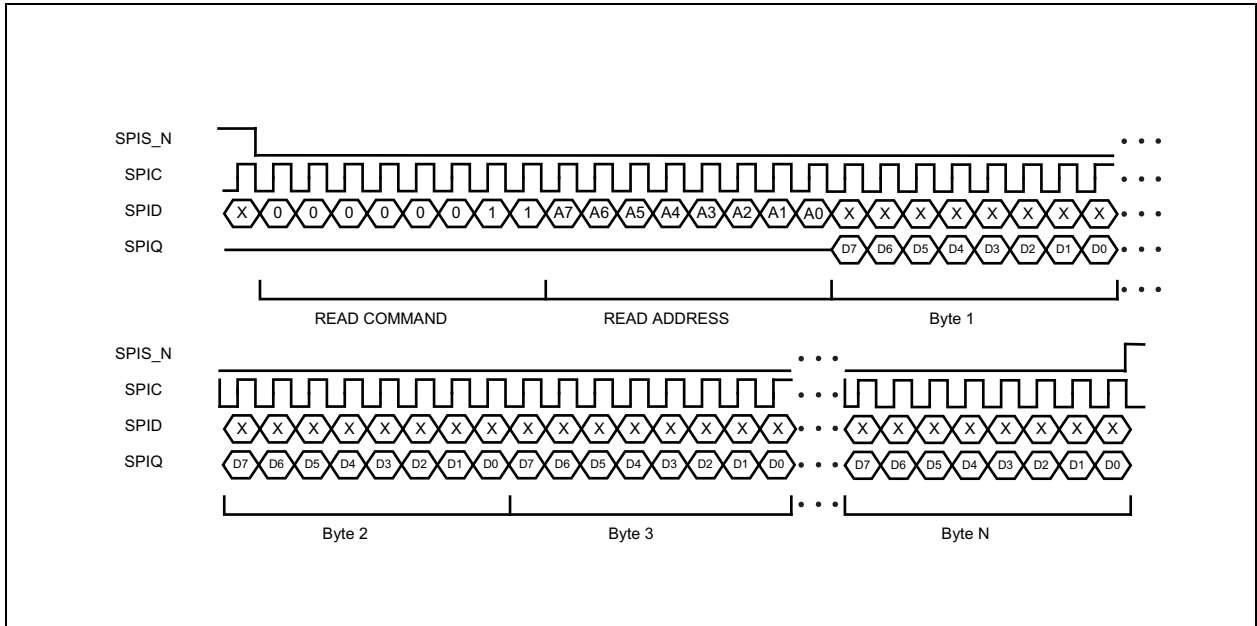

### 3.13 Loopback Support

The KSZ8873MLL/FLL/RLL provides loopback support for remote diagnostic of failure. In loopback mode, the speed at both PHY ports needs to be set to 100BASE-TX. Two types of loopback are supported: Far-end Loopback and Near-end (Remote) Loopback.

# KSZ8873MLL/FLL/RLL

## 3.13.1 FAR-END LOOPBACK

Far-end loopback is conducted between the KSZ8873MLL/FLL/RLL's two PHY ports. The loopback is limited to few package a time for diagnosis purpose and cannot support large traffic. The loopback path starts at the "Originating." PHY port's receive inputs (RXP/RXM), wraps around at the "loopback" PHY port's PMD/PMA, and ends at the "Originating" PHY port's transmit outputs (TXP/TXM).

Bit [0] of registers 29 and 45 is used to enable far-end loopback for ports 1 and 2, respectively. Alternatively, the MII Management register 0, bit [14] can be used to enable far-end loopback.

The far-end loopback path is illustrated in [Figure 3-13](#).

**FIGURE 3-13: FAR-END LOOPBACK PATH**

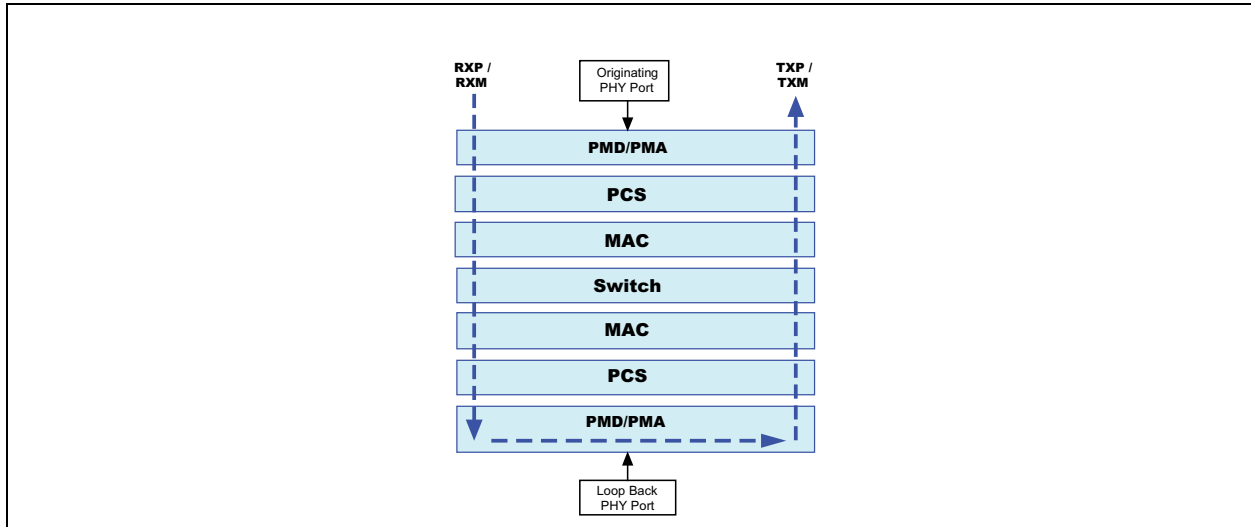

## 3.13.2 NEAR-END (REMOTE) LOOPBACK

Near-end (Remote) loopback is conducted at either PHY port 1 or PHY port 2 of the KSZ8873MLL/FLL/RLL. The loopback path starts at the PHY port's receive inputs (RXPx/RXMx), wraps around at the same PHY port's PMD/PMA, and ends at the PHY port's transmit outputs (TXPx/TXMx).

Bit [1] of registers 26 and 42 is used to enable near-end loopback for ports 1 and 2, respectively. Alternatively, the MII Management register 31, bit [1] can be used to enable near-end loopback.

The near-end loopback paths are illustrated in [Figure 3-14](#).

FIGURE 3-14: NEAR-END (REMOTE) LOOPBACK PATH

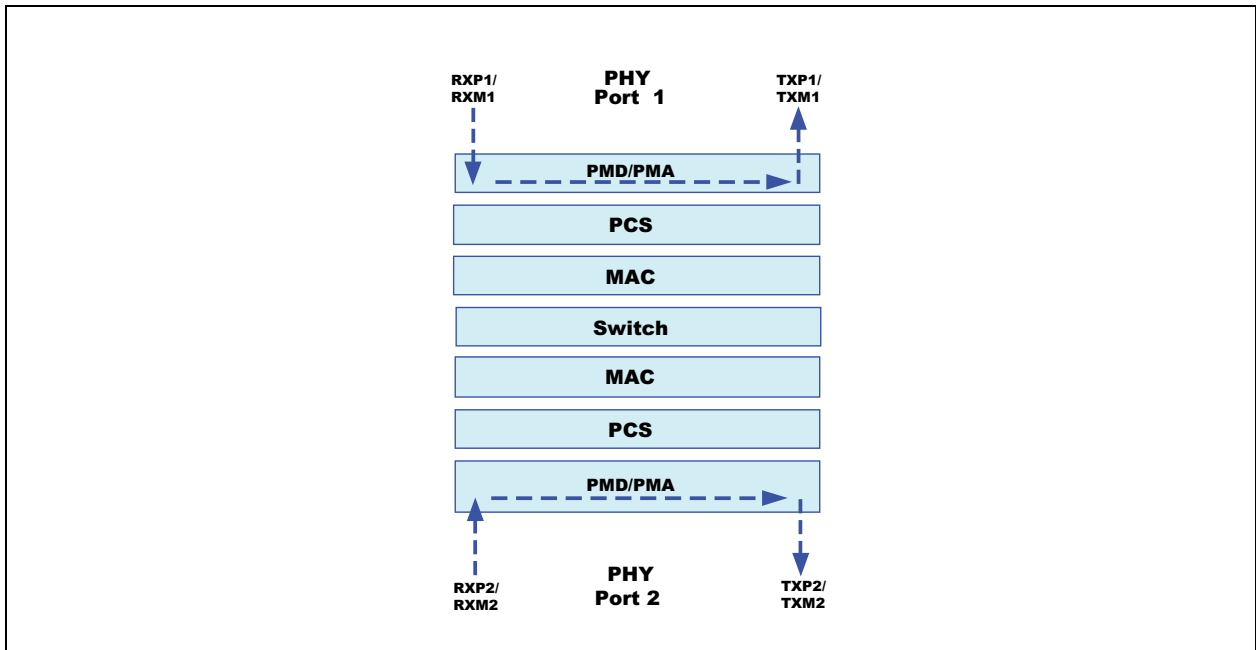



# KSZ8873MLL/FLL/RLL

## 4.0 REGISTER DESCRIPTIONS

### 4.1 MII Management (MIIM) Registers

The MIIM interface is used to access the MII PHY registers defined in this section. The SPI, I<sup>2</sup>C, and SMI interfaces can also be used to access some of these registers. The latter three interfaces use a different mapping mechanism than the MIIM interface.

The “PHYADs” by defaults are assigned “0x1” for PHY1 (port 1) and “0x2” for PHY2 (port 2). Additionally, these “PHY-ADs” can be programmed to the PHY addresses specified in bits[7:3] of Register 15 (0x0F): Global Control 13.

The “REGAD” supported are 0x0-0x5, 0x1D, and 0x1F.

**TABLE 4-1: MIIM REGISTERS FOR KSZ8873MLL/FLL/RLL**

Register Number	Description
PHYAD = 0x1, REGAD = 0x0	PHY1 Basic Control Register
PHYAD = 0x1, REGAD = 0x1	PHY1 Basic Status Register
PHYAD = 0x1, REGAD = 0x2	PHY1 Physical Identifier I
PHYAD = 0x1, REGAD = 0x3	PHY1 Physical Identifier II
PHYAD = 0x1, REGAD = 0x4	PHY1 Auto-Negotiation Advertisement Register
PHYAD = 0x1, REGAD = 0x5	PHY1 Auto-Negotiation Link Partner Ability Register
PHYAD = 0x1, 0x6 – 0x1C	PHY1 Not supported
PHYAD = 0x1, 0x1D	PHY1 Not supported
PHYAD = 0x1, 0x1E	PHY1 Not supported
PHYAD = 0x1, 0x1F	PHY1 Special Control/Status
PHYAD = 0x2, REGAD = 0x0	PHY2 Basic Control Register
PHYAD = 0x2, REGAD = 0x1	PHY2 Basic Status Register
PHYAD = 0x2, REGAD = 0x2	PHY2 Physical Identifier I
PHYAD = 0x2, REGAD = 0x3	PHY2 Physical Identifier II
PHYAD = 0x2, REGAD = 0x4	PHY2 Auto-Negotiation Advertisement Register
PHYAD = 0x2, REGAD = 0x5	PHY2 Auto-Negotiation Link Partner Ability Register
PHYAD = 0x2, 0x6 – 0x1C	PHY2 Not supported
PHYAD = 0x2, 0x1D	PHY2 LinkMD Control/Status
PHYAD = 0x2, 0x1E	PHY2 Not supported
PHYAD = 0x2, 0x1F	PHY2 Special Control/Status

## 4.2 Register Descriptions

**TABLE 4-2: REGISTER DESCRIPTIONS**

Bit	Name	R/W	Description	Default	Reference
<b>PHY1 Register 0 (PHYAD = 0x1, REGAD = 0x0): MII Basic Control</b>					
<b>PHY2 Register 0 (PHYAD = 0x2, REGAD = 0x0): MII Basic Control</b>					
15	Soft Reset	RO	Not Supported	0	—
14	Loopback	R/W	1 = Perform loopback, as indicated: Port 1 Loopback (reg. 29, bit 0 = '1') Start: RXP2/RXM2 (port 2) Loopback: PMD/PMA of port 1's PHY End: TXP2/TXM2 (port 2) Port 2 Loopback (reg. 45, bit 0 = '1') Start: RXP1/RXM1 (port 1) Loopback: PMD/PMA of port 2's PHY End: TXP1/TXM1 (port 1) 0 = Normal operation	0	Reg. 29, bit 0 Reg. 45, bit 0
13	Force 100	R/W	1 = 100 Mbps 0 = 10 Mbps	0	Reg. 28, bit 6 Reg. 44, bit 6
12	AN Enable	R/W	1 = Auto-negotiation enabled 0 = Auto-negotiation disabled	1	Reg. 28, bit 7 Reg. 44, bit 7
11	Power Down	R/W	1 = Power down 0 = Normal operation	0	Reg. 29, bit 3 Reg. 45, bit 3
10	Isolate	RO	Not Supported	0	—
9	Restart AN	R/W	1 = Restart auto-negotiation 0 = Normal operation	0	Reg. 29, bit 5 Reg. 45, bit 5
8	Force Full-Duplex	R/W	1 = Full-duplex 0 = Half-duplex	0	Reg. 28, bit 5 Reg. 44, bit 5
7	Collision Test	RO	Not Supported	0	—
6	Reserved	RO	—	0	—
5	Hp_mdix	R/W	1 = HP Auto MDI/MDI-X mode 0 = Microchip Auto MDI/MDI-X mode	1	Reg. 31, bit 7 Reg. 47, bit 7
4	Force MDI	R/W	1 = Force MDI (transmit on RXP/RXM pins) 0 = Normal operation (transmit on TXP/TXM pins)	0	Reg. 29, bit 1 Reg. 45, bit 1
3	Disable MDIX	R/W	1 = Disable auto MDI-X 0 = Enable auto MDI-X	0	Reg. 29, bit 2 Reg. 45, bit 2
2	Disable Far-End Fault	R/W	1 = Disable far-end fault detection 0 = Normal operation	0	Reg. 29, bit 4
1	Disable Transmit	R/W	1 = Disable transmit 0 = Normal operation	0	Reg. 29, bit 6 Reg. 45, bit 6
0	Disable LED	R/W	1 = Disable LED 0 = Normal operation	0	Reg. 29, bit 7 Reg. 45, bit 7
<b>PHY1 Register 1 (PHYAD = 0x1, REGAD = 0x1): MII Basic Status</b>					
<b>PHY2 Register 1 (PHYAD = 0x2, REGAD = 0x1): MII Basic Status</b>					
15	T4 Capable	RO	0 = Not 100BASE-T4 capable	0	—
14	100 Full Capable	RO	1 = 100BASE-TX full-duplex capable 0 = Not capable of 100BASE-TX full-duplex	1	Always 1
13	100 Half Capable	RO	1 = 100BASE-TX half-duplex capable 0 = Not 100BASE-TX half-duplex capable	1	Always 1
12	10 Full Capable	RO	1 = 10BASE-T full-duplex capable 0 = Not 10BASE-T full-duplex capable	1	Always 1

# KSZ8873MLL/FLL/RLL

**TABLE 4-2: REGISTER DESCRIPTIONS (CONTINUED)**

Bit	Name	R/W	Description	Default	Reference
11	10 Half Capable	RO	1 = 10BASE-T half-duplex capable 0 = Not 10BASE-T half-duplex capable	1	Always 1
10-7	Reserved	RO	—	0000	—
6	Preamble Suppressed	RO	Not Supported	0	—
5	AN Complete	RO	1 = Auto-negotiation complete 0 = Auto-negotiation not completed	0	Reg. 30, bit 6 Reg. 46, bit 6
4	Far-End Fault	RO	1 = Far-end fault detected 0 = No far-end fault detected	0	Reg. 31, bit 0
3	AN Capable	RO	1 = Auto-negotiation capable 0 = Not auto-negotiation capable	1	Reg. 28, bit 7 Reg. 44, bit 7
2	Link Status	RO	1 = Link is up 0 = Link is down	0	Reg. 30, bit 5 Reg. 46, bit 5
1	Jabber Test	RO	Not Supported	0	—
0	Extended Capable	RO	0 = Not extended register capable	0	—
<b>PHY1 Register 2 (PHYAD = 0x1, REGAD = 0x2): PHYID High</b>					
<b>PHY2 Register 2 (PHYAD = 0x2, REGAD = 0x2): PHYID High</b>					
15-0	PHYID High	RO	High order PHYID bits	0x0022	—
<b>PHY1 Register 3 (PHYAD = 0x1, REGAD = 0x3): PHYID Low</b>					
<b>PHY2 Register 3 (PHYAD = 0x2, REGAD = 0x3): PHYID Low</b>					
15-0	PHYID Low	RO	Low order PHYID bits	0x1430	—
<b>PHY1 Register 4 (PHYAD = 0x1, REGAD = 0x4): Auto-Negotiation Advertisement Ability</b>					
<b>PHY2 Register 4 (PHYAD = 0x2, REGAD = 0x4): Auto-Negotiation Advertisement Ability</b>					
15	Next Page	RO	Not Supported	0	—
14	Reserved	RO	—	0	—
13	Remote Fault	RO	Not Supported	0	—
12-11	Reserved	RO	—	00	—
10	Pause	R/W	1 = Advertise pause ability 0 = Do not advertise pause ability	1	Reg. 28, bit 4 Reg. 44, bit 4
9	Reserved	R/W	—	0	—
8	Adv 100 Full	R/W	1 = Advertise 100 full-duplex ability 0 = Do not advertise 100 full-duplex ability	1	Reg. 28, bit 3 Reg. 44, bit 3
7	Adv 100 Half	R/W	1 = Advertise 100 half-duplex ability 0 = Do not advertise 100 half-duplex ability	1	Reg. 28, bit 2 Reg. 44, bit 2
6	Adv 10 Full	R/W	1 = Advertise 10 full-duplex ability 0 = Do not advertise 10 full-duplex ability	1	Reg. 28, bit 1 Reg. 44, bit 1
5	Adv 10 Half	R/W	1 = Advertise 10 half-duplex ability 0 = Do not advertise 10 half-duplex ability	1	Reg. 28, bit 0 Reg. 44, bit 0
4-0	Selector Field	RO	802.3	00001	—
<b>PHY1 Register 5 (PHYAD = 0x1, REGAD = 0x5): Auto-Negotiation Link Partner Ability</b>					
<b>PHY2 Register 5 (PHYAD = 0x2, REGAD = 0x5): Auto-Negotiation Link Partner Ability</b>					
15	Next Page	RO	Not Supported	0	—
14	LP ACK	RO	Not Supported	0	—
13	Remote Fault	RO	Not Supported	0	—
12-11	Reserved	RO	—	00	—
10	Pause	RO	Link partner pause capability	0	Reg. 30, bit 4 Reg. 46, bit 4

# KSZ8873MLL/FLL/RLL

**TABLE 4-2: REGISTER DESCRIPTIONS (CONTINUED)**

Bit	Name	R/W	Description	Default	Reference
9	Reserved	RO	—	0	—
8	Adv 100 Full	RO	Link partner 100 full-duplex capability	0	Reg. 30, bit 3 Reg. 46, bit 3
7	Adv 100 Half	RO	Link partner 100 half-duplex capability	0	Reg. 30, bit 2 Reg. 46, bit 2
6	Adv 10 Full	RO	Link partner 10 full-duplex capability	0	Reg. 30, bit 1 Reg. 46, bit 1
5	Adv 10 Half	RO	Link partner 10 half-duplex capability	0	Reg. 30, bit 0 Reg. 46, bit 0
4-0	Reserved	RO	—	00000	—
<b>PHY1 Register 29 (PHYAD = 0x1, REGAD = 0x1D): Not support</b>					
<b>PHY2 Register 29 (PHYAD = 0x2, REGAD = 0x1D): LinkMD Control/Status</b>					
15	Vct_enable	R/W (SC)	1 = Enable cable diagnostic. After VCT test has completed, this bit will be self-cleared. 0 = Indicate cable diagnostic test (if enabled) has completed and the status information is valid for read.	0	Reg. 42, bit 4
14-13	Vct_result	RO	00 = Normal condition 01 = Open condition detected in cable 10 = Short condition detected in cable 11 = Cable diagnostic test has failed	00	Reg 42, bit[6:5]
12	Vct 10M Short	RO	1 = Less than 10 meter short	0	Reg. 42, bit 7
11-9	Reserved	RO	Reserved	000	—
8-0	Vct_- fault_count	RO	Distance to the fault. It's approximately 0.4m*vct_fault_count[8:0]	{0, (0x00)}	{{(Reg. 42, bit 0), (Reg. 43, bit[7:0])}}
<b>PHY1 Register 31 (PHYAD = 0x1, REGAD = 0x1F): PHY Special Control/Status</b>					
<b>PHY2 Register 31 (PHYAD = 0x2, REGAD = 0x1F): PHY Special Control/Status</b>					
15-6	Reserved	RO	Reserved	{{(0x00),00}	—
5	Polrvs	RO	1 = polarity is reversed 0 = polarity is not reversed	0	Reg. 31, bit 5 Reg. 47, bit 5 Note: This bit is only valid for 10BT
4	MDI-X status	RO	1 = MDI 0 = MDI-X	0	Reg. 30, bit 7 Reg. 46, bit 7
3	Force_Ink	R/W	1 = Force link pass 0 = Normal Operation	0	Reg. 26, bit 3 Reg. 42, bit 3
2	Pwrsave	R/W	0 = Enable power saving 1 = Disable power saving	1	Reg. 26, bit 2 Reg. 42, bit 2
1	Remote Loopback	R/W	1 = Perform Remote loopback, as follows: Port 1 (reg. 26, bit 1 = '1') Start: RXP1/RXM1 (port 1) Loopback: PMD/PMA of port 1's PHY End: TXP1/TXM1 (port 1) Port 2 (reg. 42, bit 1 = '1') Start: RXP2/RXM2 (port 2) Loopback: PMD/PMA of port 2's PHY End: TXP2/TXM2 (port 2) 0 = Normal Operation	0	Reg. 26, bit 1 Reg. 42, bit 1

# KSZ8873MLL/FLL/RLL

**TABLE 4-2: REGISTER DESCRIPTIONS (CONTINUED)**

Bit	Name	R/W	Description	Default	Reference
0	Reserved	R/W	Reserved Do not change the default value.	0	—

## 4.3 Memory Map (8-Bit Registers)

**TABLE 4-3: GLOBAL REGISTERS**

Register (Decimal)	Register (Hex)	Description
0-1	0x00-0x01	Chip ID Register
2-15	0x02-0x0F	Global Control Register

**TABLE 4-4: PORT REGISTERS**

Register (Decimal)	Register (Hex)	Description
16-29	0x10-0x1D	Port 1 Control Registers, including MII PHY Registers
30-31	0x1E-0x1F	Port 1 Status Registers, including MII PHY Registers
32-45	0x20-0x2D	Port 2 Control Registers, including MII PHY Registers
46-47	0x2E-0x2F	Port 2 Status Registers, including MII PHY Registers
48-57	0x30-0x39	Port 3 Control Registers
58-62	0x3A-0x3E	Reserved
63	0x3F	Port 3 Status Register
64-95	0x40-0x5F	Reserved

**TABLE 4-5: ADVANCED CONTROL REGISTERS**

Register (Decimal)	Register (Hex)	Description
96-111	0x60-0x6F	TOS Priority Control Registers
112-117	0x70-0x75	Switch Engine's MAC Address Registers
118-120	0x76-0x78	User Defined Registers
121-122	0x79-0x7A	Indirect Access Control Registers
123-131	0x7B-0x83	Indirect Data Registers
142-153	0x8E-0x99	Station Address
154-165	0x9A-0xA5	Egress Data Rate Limit
166	0xA6	Device Mode Indicator
167-170	0xA7-0xAA	High Priority Packet Buffer Reserved
171-174	0xAB-0xAE	PM Usage Flow Control Select Mode
175-186	0xAF-0xBA	TXQ Split
187-188	0xBB-0xBC	Link Change Interrupt Register
189	0xBD	Force Pause Off Iteration Limit Enable
192	0xC0	Fiber Signal Threshold
194	0xC2	Insert SRC PVID
195	0xC3	Power Management and LED Mode
196	0xC4	Sleep Mode
198	0xC6	Forward Invalid VID Frame and Host Mode

## 4.4 Register Descriptions

**TABLE 4-6: GLOBAL REGISTERS (0-15)**

Bit	Name	R/W	Description	Default
<b>Register 0 (0x00): Chip ID0</b>				
7-0	Family ID	RO	Chip family	0x88
<b>Register 1 (0x01): Chip ID1/Start Switch</b>				
7-4	Chip ID	RO	0x3 is assigned to M series. (73M)	0x3
3-1	Revision ID	RO	Revision ID	—
0	Start Switch	R/W	1 = start the switch (default) 0 = stop the switch	1
<b>Register 2 (0x02): Global Control 0</b>				
7	New Back-Off Enable	R/W	New back-off algorithm designed for UNH 1 = Enable 0 = Disable	0
6	Reserved	RO	Reserved	0
5	Flush Dynamic MAC Table	R/W	1 = enable flush dynamic MAC table for spanning tree application 0 = disable	0
4	Flush Static MAC Table	R/W	1 = enable flush static MAC table for spanning tree application 0 = disable	0
3	Pass Flow Control Packet	R/W	1 = switch will pass 802.1x flow control packets 0 = switch will drop 802.1x flow control packets	0
2	Reserved	R/W	Reserved Do not change the default value.	0
1	Reserved	R/W	Reserved Do not change the default value.	0
0	Reserved	RO	Reserved	0
<b>Register 3 (0x03): Global Control 1</b>				
7	Pass All Frames	R/W	1 = switch all packets including bad ones. Used solely for debugging purposes. Works in conjunction with sniffer mode only.	0
6	Port 3 Tail Tag Mode Enable	R/W	1 = Enable port 3 tail tag mode. 0 = Disable.	0
5	IEEE 802.3x Transmit Direction Flow Control Enable	R/W	1 = will enable transmit direction flow control feature. 0 = will not enable transmit direction flow control feature. Switch will not generate any flow control (PAUSE) frame.	1
4	IEEE 802.3x Receive Direction Flow Control Enable	R/W	1 = will enable receive direction flow control feature. 0 = will not enable receive direction flow control feature. Switch will not react to any flow control (PAUSE) frame it receives.	1
3	Frame Length Field Check	R/W	1 = will check frame length field in the IEEE packets. If the actual length does not match, the packet will be dropped (for Length/Type field < 1500). 0 = will not check	0
2	Aging Enable	R/W	1 = enable age function in the chip 0 = disable age function in the chip	1
1	Fast Age Enable	R/W	1 = turn on fast age (800 $\mu$ s)	0

# KSZ8873MLL/FLL/RLL

**TABLE 4-6: GLOBAL REGISTERS (0-15) (CONTINUED)**

Bit	Name	R/W	Description	Default
0	Aggressive Back-Off Enable	R/W	1 = enable more aggressive back off algorithm in half-duplex mode to enhance performance. This is not an IEEE standard.	0
<b>Register 4 (0x04): Global Control 2</b>				
7	Unicast Port-VLAN Mismatch Discard	R/W	This feature is used with port-VLAN (described in reg. 17, reg. 33, etc.) 1 = all packets cannot cross VLAN boundary 0 = unicast packets (excluding unknown/multicast/broadcast) can cross VLAN boundary Note: Port mirroring is not supported if this bit is set to "0".	1
6	Multicast Storm Protection Disable	R/W	1 = Broadcast Storm Protection does not include multicast packets. Only DA = FF-FF-FF-FF-FF-FF packets will be regulated. 0 = Broadcast Storm Protection includes DA = FF-FF-FF-FF-FF-FF and DA[40] = 1 packets.	1
5	Back Pressure Mode	R/W	1 = carrier sense based back pressure is selected 0 = collision based back pressure is selected	1
4	Flow Control and Back Pressure Fair Mode	R/W	1 = Fair mode is selected. In this mode, if a flow control port and a non-flow control port talk to the same destination port, packets from the non-flow control port may be dropped. This is to prevent the flow control port from being flow controlled for an extended period of time. 0 = In this mode, if a flow control port and a non-flow control port talk to the same destination port, the flow control port will be flow controlled. This may not be "fair" to the flow control port.	1
3	No Excessive Collision Drop	R/W	1 = the switch will not drop packets when 16 or more collisions occur. 0 = the switch will drop packets when 16 or more collisions occur.	0
2	Huge Packet Support	R/W	1 = will accept packet sizes up to 1916 bytes (inclusive). This bit setting will override setting from bit 1 of this register. 0 = the max packet size will be determined by bit 1 of this register.	0
1	Legal Maximum Packet Size Check Enable	R/W	0 = will accept packet sizes up to 1536 bytes (inclusive). 1 = 1522 bytes for tagged packets, 1518 bytes for untagged packets. Any packets larger than the specified value will be dropped.	0
0	Reserved	R/W	Reserved Do not change the default value.	0
<b>Register 5 (0x05): Global Control 3</b>				
7	802.1Q VLAN Enable	R/W	1 = 802.1Q VLAN mode is turned on. VLAN table needs to set up before the operation. 0 = 802.1Q VLAN is disabled.	0
6	IGMP Snoop Enable on Switch MII Interface	R/w	1 = IGMP snoop is enabled. All IGMP packets will be forwarded to the Switch MII port. 0 = IGMP snoop is disabled.	0
5	Reserved	RO	Reserved Do not change the default values.	0

# KSZ8873MLL/FLL/RLL

**TABLE 4-6: GLOBAL REGISTERS (0-15) (CONTINUED)**

Bit	Name	R/W	Description	Default
4	Reserved	RO	Reserved Do not change the default values.	0
3	Weighted Fair Queue Enable	R/W	0 = Priority method set by the registers 175-186 bit [7] = 0 for port 1, port 2, and port 3. 1 = Weighted Fair Queuing enabled. When all four queues have packets waiting to transmit, the bandwidth allocation is q3:q2:q1:q0 = 8:4:2:1. If any queues are empty, the highest non-empty queue gets one more weighting. For example, if q2 is empty, q3:q2:q1:q0 becomes (8+1):0:2:1.	0
2	Reserved	RO	Reserved Do not change the default values.	0
1	Reserved	RO	Reserved Do not change the default values.	0
0	Sniff Mode Select	R/W	1 = will do RX AND TX sniff (both source port and destination port need to match) 0 = will do RX OR TX sniff (either source port or destination port needs to match). This is the mode used to implement RX only sniff.	0
<b>Register 6 (0x06): Global Control 4</b>				
7	Reserved	RO	Reserved Do not change the default values.	0
6	Port 3 Duplex Mode Selection	R/W	1 = Enable Port 3 MII to half-duplex mode. 0 = Enable Port 3 MII to full-duplex mode.	0 Pin P1LED0 strap option. Pull-up(1): Half-duplex mode Pull-down(0): Full-duplex mode (default) Note: P1LED0 has internal pull-down.
5	Port 3 Flow Control Enable	R/W	1 = Enable full-duplex flow control on Switch port 3 MII interface. 0 = Disable full-duplex flow control on Switch port 3 MII interface.	1 Pin P1LED1 strap option. Pull-up(1): Enable flow control Pull-down(0): Disable flow control Note: P1LED1 has internal pull-up.



# KSZ8873MLL/FLL/RLL

**TABLE 4-6: GLOBAL REGISTERS (0-15) (CONTINUED)**

Bit	Name	R/W	Description	Default
4	Port 3 Speed Selection	R/W	1 = the Port 3 MII switch interface is in 10 Mbps mode 0 = the Port 3 MII switch interface is in 100 Mbps mode	0 Pin P3SPD strap option. Pull-up(1): Enable 10 Mbps Pull-down(0): Enable 100 Mbps (default) Note: P3SPD has internal pull-down.
3	Null VID Replacement	R/W	1 = will replace NULL VID with port VID (12 bits) 0 = no replacement for NULL VID	0
2-0	Broadcast Storm Protection Rate Bit [10:8]	R/W	This register along with the next register determines how many "64 byte blocks" of packet data are allowed on an input port in a preset period. The period is 67 ms for 100BT or 500 ms for 10BT. The default is 1%.	000
<b>Register 7 (0x07): Global Control 5</b>				
7-0	Broadcast Storm Protection Rate Bit [7:0]	R/W	This register along with the previous register determines how many "64 byte blocks" of packet data are allowed on an input port in a preset period. The period is 67 ms for 100BT or 500 ms for 10BT. The default is 1%. Note: 100BT Rate: 148,800 frames/sec * 67 ms/interval * 1% = 99 frames/interval (approx.) = 0x63	0x63
<b>Register 8 (0x08): Global Control 6</b>				
7-0	Factory Testing	RO	Reserved Do not change the default values.	0x00
<b>Register 9 (0x09): Global Control 7</b>				
7-0	Factory Testing	RO	Reserved Do not change the default values.	0x24
<b>Register 10 (0x0A): Global Control 8</b>				
7-0	Factory Testing	RO	Reserved Do not change the default values.	0x35
<b>Register 11 (0x0B): Global Control 9</b>				
7-6	CPU Interface Clock Selection	R/W	00 = 31.25 MHz supports SPI speed below 6 MHz 01 = 62.5 MHz supports SPI speed between 6 MHz to 12.5 MHz 10 = 125 MHz supports SPI speed above 12.5 MHz Note: Lower clock speed will save more power; It is better set to 31.25 MHz if SPI doesn't request a high speed.	10
5-4	Reserved	RO	N/A Don't Change	00
3-2	Reserved	RO	N/A Don't Change	10
1	Reserved	RO	N/A Don't Change	0
0	Reserved	RO	N/A Don't Change	0
<b>Register 12 (0x0C): Global Control 10</b>				
7-6	Tag_0x3	R/W	IEEE 802.1p mapping. The value in this field is used as the frame's priority when its IEEE 802.1p tag has a value of 0x3.	01

**TABLE 4-6: GLOBAL REGISTERS (0-15) (CONTINUED)**

Bit	Name	R/W	Description	Default
5-4	Tag_0x2	R/W	IEEE 802.1p mapping. The value in this field is used as the frame's priority when its IEEE 802.1p tag has a value of 0x2.	01
3-2	Tag_0x1	R/W	IEEE 802.1p mapping. The value in this field is used as the frame's priority when its IEEE 802.1p tag has a value of 0x1.	00
1-0	Tag_0x0	R/W	IEEE 802.1p mapping. The value in this field is used as the frame's priority when its IEEE 802.1p tag has a value of 0x0.	00
<b>Register 13 (0x0D): Global Control 11</b>				
7-6	Tag_0x7	R/W	IEEE 802.1p mapping. The value in this field is used as the frame's priority when its IEEE 802.1p tag has a value of 0x7.	11
5-4	Tag_0x6	R/W	IEEE 802.1p mapping. The value in this field is used as the frame's priority when its IEEE 802.1p tag has a value of 0x6.	11
3-2	Tag_0x5	R/W	IEEE 802.1p mapping. The value in this field is used as the frame's priority when its IEEE 802.1p tag has a value of 0x5.	10
1-0	Tag_0x4	R/W	IEEE 802.1p mapping. The value in this field is used as the frame's priority when its IEEE 802.1p tag has a value of 0x4.	10
<b>Register 14 (0x0E): Global Control 12</b>				
7	Unknown Packet Default Port Enable	R/W	Send packets with unknown destination MAC addresses to specified port(s) in bits [2:0] of this register. 0 = disable 1 = enable	0
6	Drive Strength of I/O Pad	R/W	1: 16 mA 0: 8 mA	1
5	Reserved	RO	Reserved Do not change the default values.	0
4	Reserved	RO	Reserved Do not change the default values.	0
3	Reserved	RO	Reserved Do not change the default values.	0
2-0	Unknown Packet Default Port	R/W	Specify which port(s) to send packets with unknown destination MAC addresses. This feature is enabled by bit [7] of this register. Bit 2 stands for port 3. Bit 1 stands for port 2. Bit 0 stands for port 1.  A '1' includes a port. A '0' excludes a port.	111
<b>Register 15 (0x0F): Global Control 13</b>				

# KSZ8873MLL/FLL/RLL

**TABLE 4-6: GLOBAL REGISTERS (0-15) (CONTINUED)**

Bit	Name	R/W	Description	Default
7-3	PHY Address	R/W	00000: N/A 00001: Port 1 PHY address is 0x1 00010: Port 1 PHY address is 0x2 ... 11101: Port 1 PHY address is 0x29 11110: N/A 11111: N/A  Note: Port 2 PHY address = (Port 1 PHY address) + 1	00001
2-0	Reserved	RO	Reserved Do not change the default values.	000

# KSZ8873MLL/FLL/RLL

The following registers are used to enable features that are assigned on a per port basis. The register bit assignments are the same for all ports, but the address for each port is different, as indicated.

**TABLE 4-7: PORT REGISTERS (REGISTERS 16 - 95)**

Bit	Name	R/W	Description	Default
<b>Register 16 (0x10): Port 1 Control 0</b>				
<b>Register 32 (0x20): Port 2 Control 0</b>				
<b>Register 48 (0x30): Port 3 Control 0</b>				
7	Broadcast Storm Protection Enable	R/W	1 = enable broadcast storm protection for ingress packets on port 0 = disable broadcast storm protection	0
6	DiffServ Priority Classification Enable	R/W	1 = enable DiffServ priority classification for ingress packets (IPv4) on port 0 = disable DiffServ function	0
5	802.1p Priority Classification Enable	R/W	1 = enable 802.1p priority classification for ingress packets on port 0 = disable 802.1p	0
4-3	Port-based Priority Classification	R/W	00 = ingress packets on port will be classified as priority 0 queue if "Diffserv" or "802.1p" classification is not enabled or fails to classify. 01 = ingress packets on port will be classified as priority 1 queue if "Diffserv" or "802.1p" classification is not enabled or fails to classify. 10 = ingress packets on port will be classified as priority 2 queue if "Diffserv" or "802.1p" classification is not enabled or fails to classify. 11 = ingress packets on port will be classified as priority 3 queue if "Diffserv" or "802.1p" classification is not enabled or fails to classify. Note: "DiffServ," "802.1p," and port priority can be enabled at the same time. The OR'ed result of 802.1p and DSCP overwrites the port priority.	00
2	Tag Insertion	R/W	1 = when packets are output on the port, the switch will add 802.1p/q tags to packets without 802.1p/q tags when received. The switch will not add tags to packets already tagged. The tag inserted is the ingress port's "port VID". 0 = disable tag insertion Note: For the tag insertion available, the register 194 bits [5:0] have to be set first.	0
1	Tag Removal	R/W	1 = when packets are output on the port, the switch will remove 802.1p/q tags from packets with 802.1p/q tags when received. The switch will not modify packets received without tags. 0 = disable tag removal	0
0	TXQ Split Enable	R/W	1 = split TXQ to 4 queue configuration. It cannot be enable at the same time with split 2 queue at register 18, 34, 50 bit 7. 0 = no split, treated as 1 queue configuration	0
<b>Register 17 (0x11): Port 1 Control 1</b>				
<b>Register 33 (0x21): Port 2 Control 1</b>				
<b>Register 49 (0x31): Port 3 Control 1</b>				
7	Sniffer Port	R/W	1 = Port is designated as sniffer port and will transmit packets that are monitored. 0 = Port is a normal port	0

# KSZ8873MLL/FLL/RLL

**TABLE 4-7: PORT REGISTERS (REGISTERS 16 - 95) (CONTINUED)**

Bit	Name	R/W	Description	Default
6	Receive Sniff	R/W	1 = All packets received on the port will be marked as “monitored packets” and forwarded to the designated “sniffer port” 0 = no receive monitoring	0
5	Transmit Sniff	R/W	1 = All packets transmitted on the port will be marked as “monitored packets” and forwarded to the designated “sniffer port” 0 = no transmit monitoring	0
4	Double Tag	R/W	1 = All packets will be tagged with port default tag of ingress port regardless of the original packets are tagged or not 0 = do not double tagged on all packets	0
3	User Priority Ceiling	R/W	1 = if the packet’s “user priority field” is greater than the “user priority field” in the port default tag register, replace the packet’s “user priority field” with the “user priority field” in the port default tag register. 0 = do not compare and replace the packet’s ‘user priority field”	0
2-0	Port VLAN Membership	R/W	Define the port’s egress port VLAN membership. The port can only communicate within the membership. Bit 2 stands for port 3, bit 1 stands for port 2, bit 0 stands for port 1. An ‘1’ includes a port in the membership. An ‘0’ excludes a port from membership.	111
<b>Register 18 (0x12): Port 1 Control 2</b>				
<b>Register 34 (0x22): Port 2 Control 2</b>				
<b>Register 50 (0x32): Port 3 Control 2</b>				
7	Enable 2 Queue Split of Tx Queue	R/W	1 = Enable It cannot be enable at the same time with split 4 queue at register 16, 32, and 48 bit 0. 0 = Disable	0
6	Ingress VLAN Filtering	R/W	1 = the switch will discard packets whose VID port membership in VLAN table bits [18:16] does not include the ingress port. 0 = no ingress VLAN filtering.	0
5	Discard non-PVID Packets	R/W	1 = the switch will discard packets whose VID does not match ingress port default VID. 0 = no packets will be discarded	0
4	Force Flow Control	R/W	1 = will always enable full-duplex flow control on the port, regardless of AN result. 0 = full-duplex flow control is enabled based on AN result.	Pin value during reset: For port 1, P1FFC pin For port 2, SMRXD30 pin For port 3, this bit has no meaning. Flow control is set by Reg. 6 bit 5.
3	Back Pressure Enable	R/W	1 = enable port’s half-duplex back pressure 0 = disable port’s half-duplex back pressure	0
2	Transmit Enable	R/W	1 = enable packet transmission on the port 0 = disable packet transmission on the port Note: This bit is used for spanning tree support.	1

# KSZ8873MLL/FLL/RLL

**TABLE 4-7: PORT REGISTERS (REGISTERS 16 - 95) (CONTINUED)**

Bit	Name	R/W	Description	Default
1	Receive Enable	R/W	1 = enable packet reception on the port 0 = disable packet reception on the port Note: This bit is used for spanning tree support.	1
0	Learning Disable	R/W	1 = disable switch address learning capability 0 = enable switch address learning Note: This bit is used for spanning tree support.	0
<b>Register 19 (0x13): Port 1 Control 3</b> <b>Register 35 (0x23): Port 2 Control 3</b> <b>Register 51 (0x33): Port 3 Control 3</b>				
7-0	Default Tag [15:8]	R/W	Port's default tag, containing 7-5 = User priority bits 4 = CFI bit 3-0 = VID[11:8]	0x00
<b>Register 20 (0x14): Port 1 Control 4</b> <b>Register 36 (0x24): Port 2 Control 4</b> <b>Register 52 (0x34): Port 3 Control 4</b>				
7-0	Default Tag [7:0]	R/W	Port's default tag, containing 7-0: VID[7:0]	0x01
Note: Registers 19 and 20 (and those corresponding to other ports) serve two purposes: Associated with the ingress untagged packets, and used for egress tagging. Default VID for the ingress untagged or null-VID-tagged packets, and used for address lookup.				
<b>Register 21 (0x15): Port 1 Control 5</b> <b>Register 37 (0x25): Port 2 Control 5</b> <b>Register 53 (0x35): Port 3 Control 5</b>				
7	Port 3 MII Mode Selection	R/W	1 = Port 3 MII MAC mode 0 = Port 3 MII PHY mode Note: Bit 7 is reserved in the port 1 and port 2 of the port register control 5. But its recommended to set the register 21 port 1 control 5 bit [7] = '1' for better EMI, because this bit 7 of the register 21 is for port 1 MII of the MML part. In the MLL/FLL/RLL parts, setting this bit will disable the unused internal 25 MHz clock for the unused port 1 MII PHY mode circuits.	Inversion of power strapped value of SMRXDV3
6	Self-Address Filtering Enable MACA1 (not for 0x35)	R/W	1 = enable port 1 self-address filtering MACA1 0 = disable	0
5	Self-Address Filtering Enable MACA2 (not for 0x35)	R/W	1 = enable port 2 self-address filtering MACA2 0 = disable	0
4	Drop Ingress Tagged Frame	R/W	1 = Enable 0 = Disable	0
3-2	Limit Mode	R/W	Ingress Limit Mode These bits determine what kinds of frames are limited and counted against ingress rate limiting. 00 = limit and count all frames 01 = limit and count Broadcast, Multicast, and flooded unicast frames 10 = limit and count Broadcast and Multicast frames only 11 = limit and count Broadcast frames only	00

# KSZ8873MLL/FLL/RLL

**TABLE 4-7: PORT REGISTERS (REGISTERS 16 - 95) (CONTINUED)**

Bit	Name	R/W	Description	Default
1	Count IFG	R/W	Count IFG bytes 1 = each frame's minimum inter frame gap (IFG) bytes (12 per frame) are included in Ingress and Egress rate limiting calculations. 0 = IFG bytes are not counted.	0
0	Count Pre	R/W	Count Preamble bytes 1 = each frame's preamble bytes (8 per frame) are included in Ingress and Egress rate limiting calculations. 0 = preamble bytes are not counted.	0
<b>Register 22 [6:0] (0x16): Port 1 Q0 Ingress Data Rate Limit</b> <b>Register 38 [6:0] (0x26): Port 2 Q0 Ingress Data Rate Limit</b> <b>Register 54 [6:0] (0x36): Port 3 Q0 Ingress Data Rate Limit</b>				
7	RMII REFCLK INVERT	R/W	1: Port 3 inverted refclk selected 0: Port 3 original refclk selected Note: Bit 7 is available on port 3 in the RLL device. Other ports and devices will be reserved for this bit.	0 Note: Not applied to Reg.38 (Port 2)
6-0	Q0 Ingress Data Rate Limit	R/W	Ingress data rate limit for priority 0 frames Ingress traffic from this priority queue is shaped according to the ingress Data Rate Selected Table.	0
<b>Register 23 [6:0] (0x17): Port 1 Q1 Ingress Data Rate Limit</b> <b>Register 39 [6:0] (0x27): Port 2 Q1 Ingress Data Rate Limit</b> <b>Register 55 [6:0] (0x37): Port 3 Q1 Ingress Data Rate Limit</b>				
7	Reserved	R/W	Reserved Do not change the default values.	0
6-0	Q1 Ingress Data Rate Limit	R/W	Ingress data rate limit for priority 1 frames Ingress traffic from this priority queue is shaped according to the ingress Data Rate Selected Table.	0
<b>Register 24 [6:0] (0x18): Port 1 Q2 Ingress Data Rate Limit</b> <b>Register 40 [6:0] (0x28): Port 2 Q2 Ingress Data Rate Limit</b> <b>Register 56 [6:0] (0x38): Port 3 Q2 Ingress Data Rate Limit</b>				
7	Reserved	R/W	Reserved Do not change the default values.	0
6-0	Q2 Ingress Data Rate Limit	R/W	Ingress data rate limit for priority 2 frames Ingress traffic from this priority queue is shaped according to ingress Data Rate Selection Table.	0
<b>Register 25 [6:0] (0x19): Port 1 Q3 Ingress Data Rate Limit</b> <b>Register 41 [6:0] (0x29): Port 2 Q3 Ingress Data Rate Limit</b> <b>Register 57 [6:0] (0x39): Port 3 Q3 Ingress Data Rate Limit</b>				
7	Reserved	RO	Reserved Do not change the default values.	0
6-0	Q3 Ingress Data Rate Limit	R/W	Ingress data rate limit for priority 3 frames Ingress traffic from this priority queue is shaped according to ingress Data Rate Selection Table.	0
Note: Most of the contents in registers 26-31 and registers 42-47 for ports 1 and 2, respectively, can also be accessed with the MIIM PHY registers.				
<b>Register 26 (0x1A): Port 1 PHY Special Control/Status</b> <b>Register 42 (0x2A): Port 2 PHY Special Control/Status</b> <b>Register 58 (0x3A): Reserved, Not Applicable to Port 3</b>				
7	Vct 10M Short	RO	1 = Less than 10 meter short	0

# KSZ8873MLL/FLL/RLL

**TABLE 4-7: PORT REGISTERS (REGISTERS 16 - 95) (CONTINUED)**

Bit	Name	R/W	Description	Default
6-5	Vct_result	RO	00 = Normal condition 01 = Open condition detected in cable 10 = Short condition detected in cable 11 = Cable diagnostic test has failed	00
4	Vct_en	R/W (SC)	1 = Enable cable diagnostic test. After VCT test has completed, this bit will be self-cleared. 0 = Indicate cable diagnostic test (if enabled) has completed and the status information is valid for read.	0
3	Force_Ink	R/W	1 = Force link pass 0 = Normal Operation	0
2	Reserved	RO	Reserved Do not change the default value.	0
1	Remote Loopback	R/W	1 = Perform Remote loopback, as follows: Port 1 (reg. 26, bit 1 = '1') Start: RXP1/RXM1 (port 1) Loopback: PMD/PMA of port 1's PHY End: TXP1/TXM1 (port 1) Port 2 (reg. 42, bit 1 = '1') Start: RXP2/RXM2 (port 2) Loopback: PMD/PMA of port 2's PHY End: TXP2/TXM2 (port 2) 0 = Normal Operation	0
0	Vct_fault_count[8]	RO	Bit[8] of VCT fault count Distance to the fault. It's approximately 0.4m*vct_fault_count[8:0]	0
<b>Register 27 (0x1B): Port 1 Not Supported</b> <b>Register 43 (0x2B): Port 2 LinkMD Result</b> <b>Register 59 (0x3B): Reserved, Not Applicable to Port 3</b>				
7-0	Vct_fault_count[7:0]	RO	Bits[7:0] of VCT fault count Distance to the fault. It's approximately 0.4m*Vct_fault_count[8:0]	0x00
<b>Register 28 (0x1C): Port 1 Control 12</b> <b>Register 44 (0x2C): Port 2 Control 12</b> <b>Register 60 (0x3C): Reserved, Not Applicable to Port 3</b>				
7	Auto Negotiation Enable	R/W	1 = auto negotiation is on 0 = disable auto negotiation; speed and duplex are determined by bits 6 and 5 of this register.	1 For port 1, P1ANEN pin value during reset. For port 2, SMRXD33 pin value during reset
6	Force Speed	R/W	1 = forced 100BT if AN is disabled (bit 7) 0 = forced 10BT if AN is disabled (bit 7)	1 For port 1, P1SPD pin value during reset. For port 2, SMRXD32 pin value during reset.



# KSZ8873MLL/FLL/RLL

**TABLE 4-7: PORT REGISTERS (REGISTERS 16 - 95) (CONTINUED)**

Bit	Name	R/W	Description	Default
5	Force Duplex	R/W	1 = forced full-duplex if (1) AN is disabled or (2) AN is enabled, but failed. 0 = forced half-duplex if (1) AN is disabled or (2) AN is enabled but failed. Note: This bit or strap pin should be set to '0' for the correct duplex mode indication of LED and register status when the link-up is AN to force mode.	1 For port 1, P1DPX pin value during reset. For port 2, SMRXD31 pin value during reset.
4	Advertise Flow Control Capability	R/W	1 = advertise flow control (pause) capability 0 = suppress flow control (pause) capability from transmission to link partner	1
3	Advertise 100BT Full-Duplex Capability	R/W	1 = advertise 100BT full-duplex capability 0 = suppress 100BT full-duplex capability from transmission to link partner	1
2	Advertise 100BT Half-Duplex Capability	R/W	1 = advertise 100BT half-duplex capability 0 = suppress 100BT half-duplex capability from transmission to link partner	1
1	Advertise 10BT Full-Duplex Capability	R/W	1 = advertise 10BT full-duplex capability 0 = suppress 10BT full-duplex capability from transmission to link partner	1
0	Advertise 10BT Half-Duplex Capability	R/W	1 = advertise 10BT half-duplex capability 0 = suppress 10BT half-duplex capability from transmission to link partner	1
<b>Register 29 (0x1D): Port 1 Control 13</b> <b>Register 45 (0x2D): Port 2 Control 13</b> <b>Register 61 (0x3D): Reserved, Not Applicable to Port 3</b>				
7	LED Off	R/W	1 = turn off all port's LEDs (LEDx_1, LEDx_0, where "x" is the port number). These pins will be driven high if this bit is set to '1'. 0 = normal operation	0
6	Txdis	R/W	1 = disable the port's transmitter 0 = normal operation	0
5	Restart AN	R/W	1 = restart auto-negotiation 0 = normal operation	0
4	Disable Far-End Fault	R/W	1 = disable far-end fault detection and pattern transmission. 0 = enable far-end fault detection and pattern transmission	0
3	Power Down	R/W	1 = power down 0 = normal operation	0
2	Disable Auto MDI/MDI-X	R/W	1 = disable auto MDI/MDI-X function 0 = enable auto MDI/MDI-X function	0
1	Force MDI	R/W	If auto MDI/MDI-X is disabled, 1 = force PHY into MDI mode (transmit on RXP/RXM pins) 0 = force PHY into MDI-X mode (transmit on TXP/TXM pins)	0

# KSZ8873MLL/FLL/RLL

**TABLE 4-7: PORT REGISTERS (REGISTERS 16 - 95) (CONTINUED)**

Bit	Name	R/W	Description	Default
0	Loopback	R/W	1 = perform loopback, as indicated: Port 1 Loopback (reg. 29, bit 0 = '1') Start: RXP2/RXM2 (port 2) Loopback: PMD/PMA of port 1's PHY End: TXP2/TXM2 (port 2) Port 2 Loopback (reg. 45, bit 0 = '1') Start: RXP1/RXM1 (port 1) Loopback: PMD/PMA of port 2's PHY End: TXP1/TXM1 (port 1) 0 = normal operation	0
<b>Register 30 (0x1E): Port 1 Status 0</b>				
<b>Register 46 (0x2E): Port 2 Status 0</b>				
<b>Register 62 (0x3E): Reserved, Not Applicable to Port 3</b>				
7	MDI-X Status	RO	1 = MDI 0 = MDI-X	0
6	AN Done	RO	1 = auto-negotiation completed 0 = auto-negotiation not completed	0
5	Link Good	RO	1 = link good 0 = link not good	0
4	Partner Flow Control Capability	RO	1 = link partner flow control (pause) capable 0 = link partner not flow control (pause) capable	0
3	Partner 100BT Full-Duplex Capability	RO	1 = link partner 100BT full-duplex capable 0 = link partner not 100BT full-duplex capable	0
2	Partner 100BT Half-Duplex Capability	RO	1 = link partner 100BT half-duplex capable 0 = link partner not 100BT half-duplex capable	0
1	Partner 10BT Full-Duplex Capability	RO	1 = link partner 10BT full-duplex capable 0 = link partner not 10BT full-duplex capable	0
0	Partner 10BT Half-Duplex Capability	RO	1 = link partner 10BT half-duplex capable 0 = link partner not 10BT half-duplex capable	0
<b>Register 31 (0x1F): Port 1 Status 1</b>				
<b>Register 47 (0x2F): Port 2 Status 1</b>				
<b>Register 63 (0x3F): Port 3 Status 1</b>				
7	Hp_mdix	R/W	1 = HP Auto MDI/MDI-X mode 0 = Microchip Auto MDI/MDI-X mode	1 Note: Only ports 1 and 2 are PHY ports. This bit is not applicable to port 3 (MII).
6	Reserved	RO	Reserved Do not change the default value.	0
5	Polrvs	RO	1 = polarity is reversed 0 = polarity is not reversed	0 Note: This bit is not applicable to port 3 (MII). This bit is only valid for 10BT
4	Transmit Flow Control Enable	RO	1 = transmit flow control feature is active 0 = transmit flow control feature is inactive	0
3	Receive Flow Control Enable	RO	1 = receive flow control feature is active 0 = receive flow control feature is inactive	0

# KSZ8873MLL/FLL/RLL

**TABLE 4-7: PORT REGISTERS (REGISTERS 16 - 95) (CONTINUED)**

Bit	Name	R/W	Description	Default
2	Operation Speed	RO	1 = link speed is 100 Mbps 0 = link speed is 10 Mbps	0
1	Operation Duplex	RO	1 = link duplex is full 0 = link duplex is half	0
0	Far-End Fault	RO	1 = far-end fault status detected 0 = no far-end fault status detected	0 Note: This bit is applicable to port 1 and port 2 for FLL part only.
<b>Register 67 (0x43): Reset</b>				
4	Software Reset	R/W	1 = Software reset 0 = Clear Note: Software reset will reset all registers to the initial values of the power-on reset or warm reset (keep the strap values).	0
0	PCS Reset	R/W	1 = PCS reset is used when is doing software reset for a complete reset 0 = Clear Note: PCS reset will reset the state machine and clock domain in PHY's PCS layer.	0

**TABLE 4-8: DATA RATE LIMIT**

Data Rate Limit for Ingress or Egress	100BT Register Bit[6:0], Q = 0...3	10BT Register Bit[6:0], Q = 0...3
—	1 to 0x63 for 1 Mbps to 99 Mbps Rate 0 or 0x64 for 100 Mbps Rate	1 to 0x09 for 1 Mbps to 9 Mbps Rate 0 or 0x0A for 10 Mbps Rate
64 kbps		0x65
128 kbps		0x66
192 kbps		0x67
256 kbps		0x68
320 kbps		0x69
384 kbps		0x6A
448 kbps		0x6B
512 kbps		0x6C
576 kbps		Data 0x6D
640 kbps		0x6E
704 kbps		0x6F
768 kbps		0x70
832 kbps		0x71
896 kbps		0x72
960 kbps		0x73

## 4.5 Advanced Control Registers (Registers 96-198)

The IPv4/IPv6 TOS Priority Control Registers implement a fully decoded, 128-bit Differentiated Services Code Point (DSCP) register set that is used to determine priority from the Type of Service (TOS) field in the IP header. The most significant 6 bits of the TOS field are fully decoded into 64 possibilities, and the singular code that results is compared against the corresponding bits in the DSCP register to determine the priority.

**TABLE 4-9: ADVANCED CONTROL REGISTERS (REGISTERS 96-198)**

Bit	Name	R/W	Description	Default
<b>Register 96 (0x60): TOS Priority Control Register 0</b>				
7-6	DSCP[7:6]	R/W	The value in this field is used as the frame's priority when bits [7:2] of the frame's IP TOS/DiffServ/Traffic Class value is 0x03.	00
5-4	DSCP[5:4]	R/W	The value in this field is used as the frame's priority when bits [7:2] of the frame's IP TOS/DiffServ/Traffic Class value is 0x02.	00
3-2	DSCP[3:2]	R/W	The value in this field is used as the frame's priority when bits [7:2] of the frame's IP TOS/DiffServ/Traffic Class value is 0x01.	00
1-0	DSCP[1:0]	R/W	The value in this field is used as the frame's priority when bits [7:2] of the frame's IP TOS/DiffServ/Traffic Class value is 0x00.	00
<b>Register 97 (0x61): TOS Priority Control Register 1</b>				
7-6	DSCP[15:14]	R/W	The value in this field is used as the frame's priority when bits [7:2] of the frame's IP TOS/DiffServ/Traffic Class value is 0x07.	00
5-4	DSCP[13:12]	R/W	The value in this field is used as the frame's priority when bits [7:2] of the frame's IP TOS/DiffServ/Traffic Class value is 0x06.	00
3-2	DSCP[11:10]	R/W	The value in this field is used as the frame's priority when bits [7:2] of the frame's IP TOS/DiffServ/Traffic Class value is 0x05.	00
1-0	DSCP[9:8]	R/W	The value in this field is used as the frame's priority when bits [7:2] of the frame's IP TOS/DiffServ/Traffic Class value is 0x04.	00
<b>Register 98 (0x62): TOS Priority Control Register 2</b>				
7-6	DSCP[23:22]	R/W	The value in this field is used as the frame's priority when bits [7:2] of the frame's IP TOS/DiffServ/Traffic Class value is 0x0B.	00
5-4	DSCP[21:20]	R/W	The value in this field is used as the frame's priority when bits [7:2] of the frame's IP TOS/DiffServ/Traffic Class value is 0x0A.	00
3-2	DSCP[19:18]	R/W	The value in this field is used as the frame's priority when bits [7:2] of the frame's IP TOS/DiffServ/Traffic Class value is 0x09.	00
1-0	DSCP[17:16]	R/W	The value in this field is used as the frame's priority when bits [7:2] of the frame's IP TOS/DiffServ/Traffic Class value is 0x08.	00
<b>Register 99 (0x63): TOS Priority Control Register 3</b>				
7-6	DSCP[31:30]	R/W	The value in this field is used as the frame's priority when bits [7:2] of the frame's IP TOS/DiffServ/Traffic Class value is 0x0F.	00

# KSZ8873MLL/FLL/RLL

**TABLE 4-9: ADVANCED CONTROL REGISTERS (REGISTERS 96-198) (CONTINUED)**

Bit	Name	R/W	Description	Default
5-4	DSCP[29:28]	R/W	The value in this field is used as the frame's priority when bits [7:2] of the frame's IP TOS/DiffServ/Traffic Class value is 0x0E.	00
3-2	DSCP[27:26]	R/W	The value in this field is used as the frame's priority when bits [7:2] of the frame's IP TOS/DiffServ/Traffic Class value is 0x0D.	00
1-0	DSCP[25:24]	R/W	The value in this field is used as the frame's priority when bits [7:2] of the frame's IP TOS/DiffServ/Traffic Class value is 0x0C.	00
<b>Register 100 (0x64): TOS Priority Control Register 4</b>				
7-6	DSCP[39:38]	R/W	The value in this field is used as the frame's priority when bits [7:2] of the frame's IP TOS/DiffServ/Traffic Class value is 0x13.	00
5-4	DSCP[37:36]	R/W	The value in this field is used as the frame's priority when bits [7:2] of the frame's IP TOS/DiffServ/Traffic Class value is 0x12.	00
3-2	DSCP[35:34]	R/W	The value in this field is used as the frame's priority when bits [7:2] of the frame's IP TOS/DiffServ/Traffic Class value is 0x11.	00
1-0	DSCP[33:32]	R/W	The value in this field is used as the frame's priority when bits [7:2] of the frame's IP TOS/DiffServ/Traffic Class value is 0x10.	00
<b>Register 101 (0x65): TOS Priority Control Register 5</b>				
7-6	DSCP[47:46]	R/W	The value in this field is used as the frame's priority when bits [7:2] of the frame's IP TOS/DiffServ/Traffic Class value is 0x17.	00
5-4	DSCP[45:44]	R/W	The value in this field is used as the frame's priority when bits [7:2] of the frame's IP TOS/DiffServ/Traffic Class value is 0x16.	00
3-2	DSCP[43:42]	R/W	The value in this field is used as the frame's priority when bits [7:2] of the frame's IP TOS/DiffServ/Traffic Class value is 0x15.	00
1-0	DSCP[41:40]	R/W	The value in this field is used as the frame's priority when bits [7:2] of the frame's IP TOS/DiffServ/Traffic Class value is 0x14.	00
<b>Register 102 (0x66): TOS Priority Control Register 6</b>				
7-6	DSCP[55:54]	R/W	The value in this field is used as the frame's priority when bits [7:2] of the frame's IP TOS/DiffServ/Traffic Class value is 0x1B.	00
5-4	DSCP[53:52]	R/W	The value in this field is used as the frame's priority when bits [7:2] of the frame's IP TOS/DiffServ/Traffic Class value is 0x1A.	00
3-2	DSCP[51:50]	R/W	The value in this field is used as the frame's priority when bits [7:2] of the frame's IP TOS/DiffServ/Traffic Class value is 0x19.	00
1-0	DSCP[49:48]	R/W	The value in this field is used as the frame's priority when bits [7:2] of the frame's IP TOS/DiffServ/Traffic Class value is 0x18.	00
<b>Register 103 (0x67): TOS Priority Control Register 7</b>				
7-6	DSCP[63:62]	R/W	The value in this field is used as the frame's priority when bits [7:2] of the frame's IP TOS/DiffServ/Traffic Class value is 0x1F.	00

**TABLE 4-9: ADVANCED CONTROL REGISTERS (REGISTERS 96-198) (CONTINUED)**

Bit	Name	R/W	Description	Default
5-4	DSCP[61:60]	R/W	The value in this field is used as the frame's priority when bits [7:2] of the frame's IP TOS/DiffServ/Traffic Class value is 0x1E.	00
3-2	DSCP[59:58]	R/W	The value in this field is used as the frame's priority when bits [7:2] of the frame's IP TOS/DiffServ/Traffic Class value is 0x1D.	00
1-0	DSCP[57:56]	R/W	The value in this field is used as the frame's priority when bits [7:2] of the frame's IP TOS/DiffServ/Traffic Class value is 0x1C.	00
<b>Register 104 (0x68): TOS Priority Control Register 8</b>				
7-6	DSCP[71:70]	R/W	The value in this field is used as the frame's priority when bits [7:2] of the frame's IP TOS/DiffServ/Traffic Class value is 0x23.	00
5-4	DSCP[69:68]	R/W	The value in this field is used as the frame's priority when bits [7:2] of the frame's IP TOS/DiffServ/Traffic Class value is 0x22.	00
3-2	DSCP[67:66]	R/W	The value in this field is used as the frame's priority when bits [7:2] of the frame's IP TOS/DiffServ/Traffic Class value is 0x21.	00
1-0	DSCP[65:64]	R/W	The value in this field is used as the frame's priority when bits [7:2] of the frame's IP TOS/DiffServ/Traffic Class value is 0x20.	00
<b>Register 105 (0x69): TOS Priority Control Register 9</b>				
7-6	DSCP[79:78]	R/W	The value in this field is used as the frame's priority when bits [7:2] of the frame's IP TOS/DiffServ/Traffic Class value is 0x27.	00
5-4	DSCP[77:76]	R/W	The value in this field is used as the frame's priority when bits [7:2] of the frame's IP TOS/DiffServ/Traffic Class value is 0x26.	00
3-2	DSCP[75:74]	R/W	The value in this field is used as the frame's priority when bits [7:2] of the frame's IP TOS/DiffServ/Traffic Class value is 0x25.	00
1-0	DSCP[73:72]	R/W	The value in this field is used as the frame's priority when bits [7:2] of the frame's IP TOS/DiffServ/Traffic Class value is 0x24.	00
<b>Register 106 (0x6A): TOS Priority Control Register 10</b>				
7-6	DSCP[87:86]	R/W	The value in this field is used as the frame's priority when bits [7:2] of the frame's IP TOS/DiffServ/Traffic Class value is 0x2B.	00
5-4	DSCP[85:84]	R/W	The value in this field is used as the frame's priority when bits [7:2] of the frame's IP TOS/DiffServ/Traffic Class value is 0x2A.	00
3-2	DSCP[83:82]	R/W	The value in this field is used as the frame's priority when bits [7:2] of the frame's IP TOS/DiffServ/Traffic Class value is 0x29.	00
1-0	DSCP[81:80]	R/W	The value in this field is used as the frame's priority when bits [7:2] of the frame's IP TOS/DiffServ/Traffic Class value is 0x28.	00
<b>Register 107 (0x6B): TOS Priority Control Register 11</b>				

# KSZ8873MLL/FLL/RLL

**TABLE 4-9: ADVANCED CONTROL REGISTERS (REGISTERS 96-198) (CONTINUED)**

Bit	Name	R/W	Description	Default
7-6	DSCP[95:94]	R/W	The value in this field is used as the frame's priority when bits [7:2] of the frame's IP TOS/DiffServ/Traffic Class value is 0x2F.	00
5-4	DSCP[93:92]	R/W	The value in this field is used as the frame's priority when bits [7:2] of the frame's IP TOS/DiffServ/Traffic Class value is 0x2E.	00
3-2	DSCP[91:90]	R/W	The value in this field is used as the frame's priority when bits [7:2] of the frame's IP TOS/DiffServ/Traffic Class value is 0x2D.	00
1-0	DSCP[89:88]	R/W	The value in this field is used as the frame's priority when bits [7:2] of the frame's IP TOS/DiffServ/Traffic Class value is 0x2C.	00
<b>Register 108 (0x6C): TOS Priority Control Register 12</b>				
7-6	DSCP[103:102]	R/W	The value in this field is used as the frame's priority when bits [7:2] of the frame's IP TOS/DiffServ/Traffic Class value is 0x33.	00
5-4	DSCP[101:100]	R/W	The value in this field is used as the frame's priority when bits [7:2] of the frame's IP TOS/DiffServ/Traffic Class value is 0x32.	00
3-2	DSCP[99:98]	R/W	The value in this field is used as the frame's priority when bits [7:2] of the frame's IP TOS/DiffServ/Traffic Class value is 0x31.	00
1-0	DSCP[97:96]	R/W	The value in this field is used as the frame's priority when bits [7:2] of the frame's IP TOS/DiffServ/Traffic Class value is 0x30.	00
<b>Register 109 (0x6D): TOS Priority Control Register 13</b>				
7-6	DSCP[111:110]	R/W	The value in this field is used as the frame's priority when bits [7:2] of the frame's IP TOS/DiffServ/Traffic Class value is 0x37.	00
5-4	DSCP[109:108]	R/W	The value in this field is used as the frame's priority when bits [7:2] of the frame's IP TOS/DiffServ/Traffic Class value is 0x36.	00
3-2	DSCP[107:106]	R/W	The value in this field is used as the frame's priority when bits [7:2] of the frame's IP TOS/DiffServ/Traffic Class value is 0x35.	00
1-0	DSCP[105:104]	R/W	The value in this field is used as the frame's priority when bits [7:2] of the frame's IP TOS/DiffServ/Traffic Class value is 0x34.	00
<b>Register 110 (0x6E): TOS Priority Control Register 14</b>				
7-6	DSCP[119:118]	R/W	The value in this field is used as the frame's priority when bits [7:2] of the frame's IP TOS/DiffServ/Traffic Class value is 0x3B.	00
5-4	DSCP[117:116]	R/W	The value in this field is used as the frame's priority when bits [7:2] of the frame's IP TOS/DiffServ/Traffic Class value is 0x3A.	00
3-2	DSCP[115:114]	R/W	The value in this field is used as the frame's priority when bits [7:2] of the frame's IP TOS/DiffServ/Traffic Class value is 0x39.	00
1-0	DSCP[113:112]	R/W	The value in this field is used as the frame's priority when bits [7:2] of the frame's IP TOS/DiffServ/Traffic Class value is 0x38.	00
<b>Register 111 (0x6F): TOS Priority Control Register 15</b>				

# KSZ8873MLL/FLL/RLL

**TABLE 4-9: ADVANCED CONTROL REGISTERS (REGISTERS 96-198) (CONTINUED)**

Bit	Name	R/W	Description	Default
7-6	DSCP[127:126]	R/W	The value in this field is used as the frame's priority when bits [7:2] of the frame's IP TOS/DiffServ/Traffic Class value is 0x3F.	00
5-4	DSCP[125:124]	R/W	The value in this field is used as the frame's priority when bits [7:2] of the frame's IP TOS/DiffServ/Traffic Class value is 0x3E.	00
3-2	DSCP[123:122]	R/W	The value in this field is used as the frame's priority when bits [7:2] of the frame's IP TOS/DiffServ/Traffic Class value is 0x3D.	00
1-0	DSCP[121:120]	R/W	The value in this field is used as the frame's priority when bits [7:2] of the frame's IP TOS/DiffServ/Traffic Class value is 0x3C.	00
Registers 112 to 117 contain the switch engine's MAC address. This 48-bit address is used as the Source Address for the MAC's full duplex flow control (PAUSE) frame.				
<b>Register 112 (0x70): MAC Address Register 0</b>				
7-0	MACA[47:40]	R/W	—	0x00
<b>Register 113 (0x71): MAC Address Register 1</b>				
7-0	MACA[39:32]	R/W	—	0x10
<b>Register 114 (0x72): MAC Address Register 2</b>				
7-0	MACA[31:24]	R/W	—	0xA1
<b>Register 115 (0x73): MAC Address Register 3</b>				
7-0	MACA[23:16]	R/W	—	0xFF
<b>Register 116 (0x74): MAC Address Register 4</b>				
7-0	MACA[15:8]	R/W	—	0xFF
<b>Register 117 (0x75): MAC Address Register 5</b>				
7-0	MACA[7:0]	R/W	—	0xFF
Registers 118 to 120 are User Defined Registers (UDRs). These are general purpose read/write registers that can be used to pass user defined control and status information between the KSZ8873 and the external processor.				
<b>Register 118 (0x76): User Defined Register 1</b>				
7-0	UDR1	R/W	—	0x00
<b>Register 119 (0x77): User Defined Register 2</b>				
7-0	UDR2	R/W	—	0x00
<b>Register 120 (0x78): User Defined Register 3</b>				
7-0	UDR3	R/W	—	0x00
Registers 121 to 131 provide read and write access to the static MAC address table, VLAN table, dynamic MAC address table, and MIB counters.				
<b>Register 121 (0x79): Indirect Access Control 0</b>				
7-5	Reserved	R/W	Reserved Do not change the default values.	000
4	Read High/Write Low	R/W	1 = read cycle 0 = write cycle	0
3-2	Table Select	R/W	00 = static MAC address table selected 01 = VLAN table selected 10 = dynamic MAC address table selected 11 = MIB counter selected	00
1-0	Indirect Address High	R/W	Bits [9:8] of indirect address	00
<b>Register 122 (0x7A): Indirect Access Control 1</b>				



# KSZ8873MLL/FLL/RLL

**TABLE 4-9: ADVANCED CONTROL REGISTERS (REGISTERS 96-198) (CONTINUED)**

Bit	Name	R/W	Description	Default
7-0	Indirect Address Low	R/W	Bits [7:0] of indirect address. Note: A write to register 122 triggers the read/write command. Read or write access is determined by register 121 bit 4.	0000_0000
<b>Register 123 (0x7B): Indirect Data Register 8</b>				
7	CPU Read Status	RO	This bit is applicable only for dynamic MAC address table and MIB counter reads. 1 = read is still in progress 0 = read has completed	0
6-3	Reserved	RO	Reserved	0000
2-0	Indirect Data [66:64]	RO	Bits [66:64] of indirect data	000
<b>Register 124 (0x7C): Indirect Data Register 7</b>				
7-0	Indirect Data [63:56]	R/W	Bits [63:56] of indirect data	0000_0000
<b>Register 125 (0x7D): Indirect Data Register 6</b>				
7-0	Indirect Data [55:48]	R/W	Bits [55:48] of indirect data	0000_0000
<b>Register 126 (0x7E): Indirect Data Register 5</b>				
7-0	Indirect Data [47:40]	R/W	Bits [47:40] of indirect data	0000_0000
<b>Register 127 (0x7F): Indirect Data Register 4</b>				
7-0	Indirect Data [39:32]	R/W	Bits [39:32] of indirect data	0000_0000
<b>Register 128 (0x80): Indirect Data Register 3</b>				
7-0	Indirect Data [31:24]	R/W	Bits [31:24] of indirect data	0000_0000
<b>Register 129 (0x81): Indirect Data Register 2</b>				
7-0	Indirect Data [23:16]	R/W	Bits [23:16] of indirect data	0000_0000
<b>Register 130 (0x82): Indirect Data Register 1</b>				
7-0	Indirect Data [15:8]	R/W	Bits [15:8] of indirect data	0000_0000
<b>Register 131 (0x83): Indirect Data Register 0</b>				
7-0	Indirect Data [7:0]	R/W	Bits [7:0] of indirect data	0000_0000
<b>Register 147~142 (0x93~0x8E): Station Address 1 MACA1</b>				
<b>Register 153~148 (0x99~0x94): Station Address 2 MACA2</b>				
47-0	Station Address	R/W	48-bit Station address MACA1 and MACA2. Note: The station address is used for self MAC address filtering, see the port register control 5 bits [6,5] for detail.	48'h0 Note: the MSB bits[47-40] of the MAC is the register 147 and 153. The LSB bits[7-0] of MAC is the register 142 and 148.
<b>Register 154[6:0] (0x9A): Port 1 Q0 Egress Data Rate Limit</b>				
<b>Register 158[6:0] (0x9E): Port 2 Q0 Egress Data Rate Limit</b>				
<b>Register 162[6:0] (0xA2): Port 3 Q0 Egress Data Rate Limit</b>				
7	Egress Rate Limit Flow Control Enable	R/W	1 = enable egress rate limit flow control. 0 = disable	0
6-0	Q0 Egress Data Rate Limit	R/W	Egress data rate limit for priority 0 frames Egress traffic from this priority queue is shaped according to <a href="#">Table 4-8</a> .	0
<b>Register 155[6:0] (0x9B): Port 1 Q1 Egress Data Rate Limit</b>				
<b>Register 159[6:0] (0x9F): Port 2 Q1 Egress Data Rate Limit</b>				
<b>Register 163[6:0] (0xA3): Port 3 Q1 Egress Data Rate Limit</b>				
7	Reserved	R/W	Reserved Do not change the default values.	0

# KSZ8873MLL/FLL/RLL

**TABLE 4-9: ADVANCED CONTROL REGISTERS (REGISTERS 96-198) (CONTINUED)**

Bit	Name	R/W	Description	Default
6-0	Q1 Egress Data Rate Limit	R/W	Egress data rate limit for priority 1 frames Egress traffic from this priority queue is shaped according to <a href="#">Table 4-8</a> .	0
<b>Register 156[6:0] (0x9C): Port 1 Q2 Egress Data Rate Limit</b>				
<b>Register 160[6:0] (0xA0): Port 2 Q2 Egress Data Rate Limit</b>				
<b>Register 164[6:0] (0xA4): Port 3 Q2 Egress Data Rate Limit</b>				
7	Reserved	R/W	Reserved Do not change the default values.	0
6-0	Q2 Egress Data Rate Limit	R/W	Egress data rate limit for priority 2 frames Egress traffic from this priority queue is shaped according to <a href="#">Table 4-8</a> .	0
<b>Register 157[6:0] (0x9D): Port 1 Q3 Egress Data Rate Limit</b>				
<b>Register 161[6:0] (0xA1): Port 2 Q3 Egress Data Rate Limit</b>				
<b>Register 165[6:0] (0xA5): Port 3 Q3 Egress Data Rate Limit</b>				
7	Reserved	R/W	Reserved Do not change the default values.	0
6-0	Q3 Egress Data Rate Limit	R/W	Egress data rate limit for priority 3 frames Egress traffic from this priority queue is shaped according to <a href="#">Table 4-8</a> .	0
<b>Register 166 (0xA6): KSZ8873 Mode Indicator</b>				
7-0	KSZ8873 Mode Indicator	RO	bit7: 1 = Reserved bit6: 1 = 48P pkg of 2 PHY mode bit5: 1 = Reserved      0 = Reserved bit4: 1 = Port 3 RMII    0 = Port 3 MII bit3: 1 = Reserved      0 = Reserved bit2: 1 = Port 3 MAC MII 0 = Port 3 PHY MII bit1: 1 = Port 1 Copper 0 = Port 1 Fiber bit0: 1 = Port 2 Copper 0 = Port 2 Fiber	0x03 MLL 0x13 RLL 0x00 FLL
<b>Register 167 (0xA7): High Priority Packet Buffer Reserved for Q3</b>				
7-0	Reserved	RO	Reserved Do not change the default values.	0x45
<b>Register 168 (0xA8): High Priority Packet Buffer Reserved for Q2</b>				
7-0	Reserved	RO	Reserved Do not change the default values.	0x35
<b>Register 169 (0xA9): High Priority Packet Buffer Reserved for Q1</b>				
7-0	Reserved	RO	Reserved Do not change the default values.	0x25
<b>Register 170 (0xAA): High Priority Packet Buffer Reserved for Q0</b>				
7-0	Reserved	RO	Reserved Do not change the default values.	0x15
<b>Register 171 (0xAB): PM Usage Flow Control Select Mode 1</b>				
7	Reserved	RO	Reserved Do not change the default values.	0
6	Reserved	RO	Reserved Do not change the default values.	0
5-0	Reserved	RO	Reserved Do not change the default values.	0x18
<b>Register 172 (0xAC): PM Usage Flow Control Select Mode 2</b>				
7-6	Reserved	RO	Reserved Do not change the default values.	0

# KSZ8873MLL/FLL/RLL

**TABLE 4-9: ADVANCED CONTROL REGISTERS (REGISTERS 96-198) (CONTINUED)**

Bit	Name	R/W	Description	Default
5-0	Reserved	RO	Reserved Do not change the default values.	0x10
<b>Register 173 (0xAD): PM Usage Flow Control Select Mode 3</b>				
7-6	Reserved	RO	Reserved Do not change the default values.	0
5-0	Reserved	RO	Reserved Do not change the default values.	0x08
<b>Register 174 (0xAE): PM Usage Flow Control Select Mode 4</b>				
7-4	Reserved	RO	Reserved Do not change the default values.	0
3-0	Reserved	RO	Reserved Do not change the default values.	0x05
<b>Register 175 (0xAF): TXQ Split for Q3 in Port 1</b>				
7	Priority Select	R/W	0 = enable straight priority with Reg 176/177/178 bits[7]=0 and Reg 5 bit[3]=0 for higher priority first 1 = priority ratio is 8:4:2:1 for 4 queues and 2:1 for 2 queues with Reg 176/177/178 bits[7]=1.	1
6-0	Reserved	RO	Reserved Do not change the default values.	8
<b>Register 176 (0xB0): TXQ Split for Q2 in Port 1</b>				
7	Priority Select	R/W	0 = enable straight priority with Reg 175/177/178 bits[7]=0 and Reg 5 bit[3]=0 for higher priority first 1 = priority ratio is 8:4:2:1 for 4 queues and 2:1 for 2 queues with Reg 175/177/178 bits[7]=1.	1
6-0	Reserved	RO	Reserved Do not change the default values.	4
<b>Register 177 (0xB1): TXQ Split for Q1 in Port 1</b>				
7	Priority Select	R/W	0 = enable straight priority with Reg 175/176/178 bits[7]=0 and Reg 5 bit[3]=0 for higher priority first 1 = priority ratio is 8:4:2:1 for 4 queues and 2:1 for 2 queues with Reg 175/176/178 bits[7]=1.	1
6-0	Reserved	RO	Reserved Do not change the default values.	2
<b>Register 178 (0xB2): TXQ Split for Q0 in Port 1</b>				
7	Priority Select	R/W	0 = enable straight priority with Reg 175/176/177 bits[7]=0 and Reg 5 bit[3]=0 for higher priority first 1 = priority ratio is 8:4:2:1 for 4 queues and 2:1 for 2 queues with Reg 175/176/177 bits[7]=1.	1
6-0	Reserved	RO	Reserved Do not change the default values.	1
<b>Register 179 (0xB3): TXQ Split for Q3 in Port 2</b>				
7	Priority Select	R/W	0 = enable straight priority with Reg 180/181/182 bits[7]=0 and Reg 5 bit[3]=0 for higher priority first 1 = priority ratio is 8:4:2:1 for 4 queues and 2:1 for 2 queues with Reg 180/181/182 bits[7]=1.	1
6-0	Reserved	RO	Reserved Do not change the default values.	8
<b>Register 180 (0xB4): TXQ Split for Q2 in Port 2</b>				

# KSZ8873MLL/FLL/RLL

**TABLE 4-9: ADVANCED CONTROL REGISTERS (REGISTERS 96-198) (CONTINUED)**

Bit	Name	R/W	Description	Default
7	Priority Select	R/W	0 = enable straight priority with Reg 179/181/182 bits[7]=0 and Reg 5 bit[3]=0 for higher priority first 1 = priority ratio is 8:4:2:1 for 4 queues and 2:1 for 2 queues with Reg 179/181/182 bits[7]=1.	1
6-0	Reserved	RO	Reserved Do not change the default values.	4
<b>Register 181 (0xB5): TXQ Split for Q1 in Port 2</b>				
7	Priority Select	R/W	0 = enable straight priority with Reg 179/180/182 bits[7]=0 and Reg 5 bit[3]=0 for higher priority first 1 = priority ratio is 8:4:2:1 for 4 queues and 2:1 for 2 queues with Reg 179/180/182 bits[7]=1.	1
6-0	Reserved	RO	Reserved Do not change the default values.	2
<b>Register 182 (0xB6): TXQ Split for Q0 in Port 2</b>				
7	Priority Select	R/W	0 = enable straight priority with Reg 179/180/181 bits[7]=0 and Reg 5 bit[3]=0 for higher priority first 1 = priority ratio is 8:4:2:1 for 4 queues and 2:1 for 2 queues with Reg 179/180/181 bits[7]=1.	1
6-0	Reserved	RO	Reserved Do not change the default values.	1
<b>Register 183 (0xB7): TXQ Split for Q3 Port 3</b>				
7	Priority Select	R/W	0 = enable straight priority with Reg 184/185/186 bits[7]=0 and Reg 5 bit[3]=0 for higher priority first 1 = priority ratio is 8:4:2:1 for 4 queues and 2:1 for 2 queues with Reg 184/185/186 bits[7]=1.	1
6-0	Reserved	RO	Reserved Do not change the default values.	8
<b>Register 184 (0xB8): TXQ Split for Q2 Port 3</b>				
7	Priority Select	R/W	0 = enable straight priority with Reg 183/185/186 bits[7]=0 and Reg 5 bit[3]=0 for higher priority first 1 = priority ratio is 8:4:2:1 for 4 queues and 2:1 for 2 queues with Reg 183/185/186 bits[7]=1.	1
6-0	Reserved	RO	Reserved Do not change the default values.	4
<b>Register 185 (0xB9): TXQ Split for Q1 in Port 3</b>				
7	Priority Select	R/W	0 = enable straight priority with Reg 183/184/186 bits[7]=0 and Reg 5 bit[3]=0 for higher priority first 1 = priority ratio is 8:4:2:1 for 4 queues and 2:1 for 2 queues with Reg 183/184/186 bits[7]=1.	1
6-0	Reserved	RO	Reserved Do not change the default values.	2
<b>Register 186 (0xBA): TXQ Split for Q0 in Port 3</b>				
7	Priority Select	R/W	0 = enable straight priority with Reg 183/184/185 bits[7]=0 and Reg 5 bit[3]=0 for higher priority first 1 = priority ratio is 8:4:2:1 for 4 queues and 2:1 for 2 queues with Reg 183/184/185 bits[7]=1.	1
6-0	Reserved	RO	Reserved Do not change the default values.	1
<b>Register 187 (0xBB): Interrupt Enable Register</b>				

# KSZ8873MLL/FLL/RLL

**TABLE 4-9: ADVANCED CONTROL REGISTERS (REGISTERS 96-198) (CONTINUED)**

Bit	Name	R/W	Description	Default
7-0	Interrupt Enable Register	R/W	Interrupt enable register corresponding to bits in Register 188 Note: Set register 187 first and then set register 188 (W1C= Write '1' Clear) to wait the interrupt at pin 35 INTRN for the link to be changed.	0x00
<b>Register 188 (0xBC): Link Change Interrupt</b>				
7	P1 or P2 Link Change (LC) Interrupt	R/W	Set to 1 when P1 or P2 link changes in analog interface (W1C).	0
6-3	Reserved	R/W	Reserved Do not change the default values.	0
2	P3 Link Change (LC) Interrupt	R/W	Set to 1 when P3 link changes in MII interface (W1C).	0
1	P2 Link Change (LC) Interrupt	R/W	Set to 1 when P2 link changes in analog interface (W1C).	0
0	P1 MII Link Change (LC) Interrupt	R/W	Set to 1 when P1 link changes in analog interface or MII interface (W1C).	0
<b>Register 189 (0xBD): Force Pause Off Iteration Limit Enable</b>				
7-0	Force Pause Off Iteration Limit Enable	R/W	1 = Enable. It is 160 ms before requesting to invalidate flow control. 0 = Disable	0
<b>Register 192 (0xC0): Fiber Signal Threshold</b>				
7	Port 2 Fiber Signal Threshold	R/W	1 = Threshold is 2.0V 0 = Threshold is 1.2V	0
6	Port 1 Fiber Signal Threshold	R/W	1 = Threshold is 2.0V 0 = Threshold is 1.2V	0
5-0	Reserved	RO	Reserved Do not change the default value.	0
<b>Register 193 (0xC1): Internal 1.8V LDO Control</b>				
7	Reserved	RO	Reserved Do not change the default value.	0
6	Internal 1.8V LDO Disable	R/W	1 = Disable internal 1.8V LDO 0 = Enable internal 1.8V LDO	0
5-0	Reserved	RO	Reserved Do not change the default value.	0
<b>Register 194 (0xC2): Insert SRC PVID</b>				
7-6	Reserved	RO	Reserved Do not change the default value.	00
5	Insert SRC Port 1 PVID at Port 2	R/W	1= insert SRC port 1 PVID for untagged frame at egress port 2	0
4	Insert SRC Port 1 PVID at Port 3	R/W	1= insert SRC port 1 PVID for untagged frame at egress port 3	0
3	Insert SRC Port 2 PVID at Port 1	R/W	1= insert SRC port 2 PVID for untagged frame at egress port 1	0
2	Insert SRC Port 2 PVID at Port 3	R/W	1= insert SRC port 2 PVID for untagged frame at egress port 3	0
1	Insert SRC Port 3 PVID at Port 1	R/W	1= insert SRC port 3 PVID for untagged frame at egress port 1	0
0	Insert SRC Port 3 PVID at Port 2	R/W	1= insert SRC port 3 PVID for untagged frame at egress port 2	0
<b>Register 195 (0xC3): Power Management and LED Mode</b>				

# KSZ8873MLL/FLL/RLL

**TABLE 4-9: ADVANCED CONTROL REGISTERS (REGISTERS 96-198) (CONTINUED)**

Bit	Name	R/W	Description	Default
7	CPU Interface Power Down	R/W	CPU interface clock tree power down enable. 1 = Enable 0 = Disable Note: Power save a little bit when MII interface is used and the traffic is stopped in the power management with normal mode	0
6	Switch Power Down	R/W	Switch clock tree power down enable. 1 = Enable 0 = Disable Note: Power save a little bit when MII interface is used and the traffic is stopped in the power management with normal mode	0
5-4	LED Mode Selection	R/W	00 = LED0: Link/ACT, LED1: Speed 01 = LED0: Link, LED1: ACT 10 = LED0: Link/ACT, LED1: Duplex 11 = LED0: Link, LED1: Duplex Note: Item :: Pin State :: LED Definition No Link High OFF Link Low ON 100 Speed Low ON 10 Speed High OFF (Link is ON) Full-Duplex Low ON Half-Duplex High OFF (Link is ON) ACT Toggle Blinking	00
3	LED Output Mode	R/W	1 = the internal stretched energy signal from the analog module will be negated and output to LED1 and the internal device ready signal will be negated and output to LED0. 0 = the LED1/LED0 pins will indicate the regular LED outputs. Note. This is for debugging purpose.	0
2	PLL Off Enable	R/W	1 = PLL power down enable 0 = disable Note: This bit is used in Energy Detect mode with pin 27 MII_LINK_3 pull-up in bypass mode for saving power	0
1-0	Power Management Mode	R/W	Power management mode 00 = Normal Mode 01 = Energy Detection Mode 10 = Software Power Down Mode 11 = Power Saving Mode	00
<b>Register 196(0xC4): Sleep Mode</b>				
7-0	Sleep Mode	R/W	This value is used to control the minimum period the no energy event has to be detected consecutively before the device enters the low power state when the ED mode is on. The unit is 20 ms. The default go_sleep time is 1.6 seconds.	0x50
<b>Register 198 (0xC6): Forward Invalid VID Frame and Host Mode</b>				
7	Reserved	RO	Reserved Do not change the default value.	0
6-4	Forward Invid VID Frame	R/W	Forwarding ports for frame with invalid VID	3b'0

# KSZ8873MLL/FLL/RLL

**TABLE 4-9: ADVANCED CONTROL REGISTERS (REGISTERS 96-198) (CONTINUED)**

Bit	Name	R/W	Description	Default
3	P3 RMIIClock Selection	R/W	1 = Internal 0 = External	0
2	Reserved	RO	Reserved Do not change the default value.	0
1-0	Host Interface Mode	R/W	00 = I <sup>2</sup> C master mode 01 = I <sup>2</sup> C slave mode 10 = SPI slave mode 11 = SMI mode	Strapped value of P2LED1, P2LED0.

## 4.6 Static MAC Address Table

The KSZ8873 supports both a static and a dynamic MAC address table. In response to a Destination Address (DA) look up, the KSZ8873 searches both tables to make a packet forwarding decision. In response to a Source Address (SA) look up, only the dynamic table is searched for aging, migration and learning purposes.

The static DA look up result takes precedence over the dynamic DA look up result. If there is a DA match in both tables, the result from the static table is used. The entries in the static table will not be aged out by the KSZ8873.

The static table is accessed by an external processor via the SMI, SPI or I2C interfaces. The external processor performs all addition, modification and deletion of static MAC table entries.

**TABLE 4-10: FORMAT OF STATIC MAC TABLE (8 ENTRIES)**

Bit	Name	R/W	Description	Default
57-57	FID	R/W	Filter VLAN ID – identifies one of the 16 active VLANs	0000
53	Use FID	R/W	1 = use (FID+MAC) for static table look ups 0 = use MAC only for static table look ups	0
52	Override	R/W	1 = override port setting “transmit enable=0” or “receive enable=0” setting 0 = no override	0
51	Valid	R/W	1 = this entry is valid, the lookup result will be used 0 = this entry is not valid	0
50-48	Forwarding Ports	R/W	These 3 bits control the forwarding port(s): 001, forward to port 1 010, forward to port 2 100, forward to port 3 011, forward to port 1 and port 2 110, forward to port 2 and port 3 101, forward to port 1 and port 3 111, broadcasting (excluding the ingress port)	000
47-0	MAC Address	R/W	48-bit MAC Address	0x0000_0000_0000

Examples:

1. Static Address Table Read (Read the 2nd Entry)

Write to reg. 121 (0x79) with 0x10 // Read static table selected

Write to reg. 122 (0x7A) with 0x01 // Trigger the read operation

Then,

Read reg. 124 (0x7C), static table bits [57:56]

Read reg. 125 (0x7D), static table bits [55:48]

Read reg. 126 (0x7E), static table bits [47:40]

Read reg. 127 (0x7F), static table bits [39:32]

Read reg. 128 (0x80), static table bits [31:24]

Read reg. 129 (0x81), static table bits [23:16]

Read reg. 130 (0x82), static table bits [15:8]

Read reg. 131 (0x83), static table bits [7:0]

2. Static Address Table Write (Write the 8th Entry)

Write to reg. 124 (0x7C), static table bits [57:56]

Write to reg. 125 (0x7D), static table bits [55:48]

Write to reg. 126 (0x7E), static table bits [47:40]

Write to reg. 127 (0x7F), static table bits [39:32]

Write to reg. 128 (0x80), static table bits [31:24]

Write to reg. 129 (0x81), static table bits [23:16]

Write to reg. 130 (0x82), static table bits [15:8]

Write to reg. 131 (0x83), static table bits [7:0]

Write to reg. 121 (0x79) with 0x00 // Write static table selected

Write to reg. 122 (0x7A) with 0x07 // Trigger the write operation

## 4.7 VLAN Table

The KSZ8873 uses the VLAN table to perform look ups. If 802.1Q VLAN mode is enabled (register 5, bit 7 = 1), this table will be used to retrieve the VLAN information that is associated with the ingress packet. This information includes FID (filter ID), VID (VLAN ID), and VLAN membership as described in [Table 4-11](#).

**TABLE 4-11: FORMAT OF STATIC VLAN TABLE (16 ENTRIES)**

Bit	Name	R/W	Description	Default
19	Valid	R/W	1 = entry is valid 0 = entry is invalid	1
18-16	Membership	R/W	Specify which ports are members of the VLAN. If a DA lookup fails (no match in both static and dynamic tables), the packet associated with this VLAN will be forwarded to ports specified in this field. For example, 101 means port 3 and 1 are in this VLAN.	111
15-12	FID	R/W	Filter ID. KSZ8873 supports 16 active VLANs represented by these four bit fields. FID is the mapped ID. If 802.1Q VLAN is enabled, the look up will be based on FID+DA and FID+SA.	0x0
11-0	VID	R/W	IEEE 802.1Q 12 bits VLAN ID	0x001

If 802.1Q VLAN mode is enabled, KSZ8873 will assign a VID to every ingress packet. If the packet is untagged or tagged with a null VID, the packet is assigned with the default port VID of the ingress port. If the packet is tagged with non-null VID, the VID in the tag will be used. The look up process will start from the VLAN table look up. If the VID is not valid, the packet will be dropped and no address learning will take place. If the VID is valid, the FID is retrieved. The FID+DA



# KSZ8873MLL/FLL/RLL

and FID+SA lookups are performed. The FID+DA look up determines the forwarding ports. If FID+DA fails, the packet will be broadcast to all the members (excluding the ingress port) of the VLAN. If FID+SA fails, the FID+SA will be learned.

Examples:

## 1. VLAN Table Read (read the 3rd entry)

Write to reg. 121 (0x79) with 0x14 // Read VLAN table selected

Write to reg. 122 (0x7A) with 0x02 // Trigger the read operation

Then,

Read reg. 129 (0x81), VLAN table bits [19:16]

Read reg. 130 (0x82), VLAN table bits [15:8]

Read reg. 131 (0x83), VLAN table bits [7:0]

## 2. VLAN Table Write (write the 7th entry)

Write to reg. 129 (0x81), VLAN table bits [19:16]

Write to reg. 130 (0x82), VLAN table bits [15:8]

Write to reg. 131 (0x83), VLAN table bits [7:0]

Write to reg. 121 (0x79) with 0x04 // Write VLAN table selected

Write to reg. 122 (0x7A) with 0x06 // Trigger the write operation

## 4.8 Dynamic MAC Address Table

The KSZ8873 maintains the dynamic MAC address table. Only read access is allowed.

**TABLE 4-12: FORMAT OF DYNAMIC MAC ADDRESS TABLE (1K ENTRIES)**

Bit	Name	R/W	Description	Default
71	Data Not Ready	RO	1 = entry is not ready, continue retrying until this bit is set to 0 0 = entry is ready	—
70-67	Reserved	RO	Reserved	—
66	MAC Empty	RO	1 = there is no valid entry in the table 0 = there are valid entries in the table	1
65-56	Number of Valid Entries	RO	Indicates how many valid entries in the table 0x3ff means 1k entries 0x001 means 2 entries 0x000 and bit 66 = 0 means 1 entry 0x000 and bit 66 = 1 means 0 entry	00_0000_0000
55-54	Time Stamp	RO	2 bits counter for internal aging	—
53-52	Source Port	RO	The source port where FID+MAC is learned 00 = port 1 01 = port 2 10 = port 3	00
51-48	FID	RO	Filter ID	0x0
47-0	MAC Address	RO	48-bit MAC Address	0x0000_0000_0000

Example:

Dynamic MAC Address Table Read (read the 1st entry and retrieve the MAC table size)

Write to reg. 121 (0x79) with 0x18 // Read dynamic table selected

Write to reg. 122 (0x7A) with 0x00 // Trigger the read operation

Then,

Read reg. 123 (0x7B), bit [7] // if bit 7 = 1, restart (reread) from this register dynamic table bits [66:64]

Read reg. 124 (0x7C), dynamic table bits [63:56]

Read reg. 125 (0x7D), dynamic table bits [55:48]

Read reg. 126 (0x7E), dynamic table bits [47:40]

Read reg. 127 (0x7F), dynamic table bits [39:32]

Read reg. 128 (0x80), dynamic table bits [31:24]

Read reg. 129 (0x81), dynamic table bits [23:16]

Read reg. 130 (0x82), dynamic table bits [15:8]

Read reg. 131 (0x83), dynamic table bits [7:0]

## 4.9 Management Information Base (MIB) Counters

The KSZ8873 provides 34 MIB counters per port. These counters are used to monitor the port activity for network management. The MIB counters have two format groups: “Per Port” and “All Port Dropped Packet.”

**TABLE 4-13: FORMAT OF “PER PORT” MIB COUNTERS**

Bit	Name	R/W	Description	Default
31	Overflow	RO	1 = counter overflow 0 = no counter overflow	0
30	Count Valid	RO	1 = counter value is valid 0 = counter value is not valid	0
29-0	Counter Values	RO	Counter value	0

“Per Port” MIB counters are read using indirect memory access. The base address offsets and address ranges for all three ports are:

- Port 1, base is 0x00 and range is (0x00-0x1f)
- Port 2, base is 0x20 and range is (0x20-0x3f)
- Port 3, base is 0x40 and range is (0x40-0x5f)

Port 1 MIB counters are read using the indirect memory offsets in [Table 4-14](#).

**TABLE 4-14: PORT 1’S “PER PORT” MIB COUNTERS INDIRECT MEMORY OFFSETS**

Offset	Counter Name	Description
0x0	RxLoPriorityByte	Rx lo-priority (default) octet count including bad packets
0x1	RxHiPriorityByte	Rx hi-priority octet count including bad packets
0x2	RxUndersizePkt	Rx undersize packets w/ good CRC
0x3	RxFragments	Rx fragment packets w/ bad CRC, symbol errors or alignment errors
0x4	RxOversize	Rx oversize packets w/ good CRC (max: 1536 or 1522 bytes)
0x5	RxJabbers	Rx packets longer than 1522 bytes w/ either CRC errors, alignment errors, or symbol errors (depends on max packet size setting)
0x6	RxSymbolError	Rx packets w/ invalid data symbol and legal packet size.
0x7	RxCRCError	Rx packets within (64, 1522) bytes w/ an integral number of bytes and a bad CRC (upper limit depends on max packet size setting)
0x8	RxAlignmentError	Rx packets within (64, 1522) bytes w/ a non-integral number of bytes and a bad CRC (upper limit depends on max packet size setting)
0x9	RxControl8808Pkts	Number of MAC control frames received by a port with 88-08h in EtherType field
0xA	RxPausePkts	Number of PAUSE frames received by a port. PAUSE frame is qualified with EtherType (88-08h), DA, control opcode (00-01), data length (64B min), and a valid CRC
0xB	RxBroadcast	Rx good broadcast packets (not including error broadcast packets or valid multicast packets)
0xC	RxMulticast	Rx good multicast packets (not including MAC control frames, error multicast packets or valid broadcast packets)

# KSZ8873MLL/FLL/RLL

**TABLE 4-14: PORT 1'S "PER PORT" MIB COUNTERS INDIRECT MEMORY OFFSETS**

Offset	Counter Name	Description
0xD	RxUnicast	Rx good unicast packets
0xE	Rx64Octets	Total Rx packets (bad packets included) that were 64 octets in length
0xF	Rx65to127Octets	Total Rx packets (bad packets included) that are between 65 and 127 octets in length
0x10	Rx128to255Octets	Total Rx packets (bad packets included) that are between 128 and 255 octets in length
0x11	Rx256to511Octets	Total Rx packets (bad packets included) that are between 256 and 511 octets in length
0x12	Rx512to1023Octets	Total Rx packets (bad packets included) that are between 512 and 1023 octets in length
0x13	Rx1024to1522Octets	Total Rx packets (bad packets included) that are between 1024 and 1522 octets in length (upper limit depends on max packet size setting)
0x14	TxLoPriorityByte	Tx lo-priority good octet count, including PAUSE packets
0x15	TxHiPriorityByte	Tx hi-priority good octet count, including PAUSE packets
0x16	TxLateCollision	The number of times a collision is detected later than 512 bit-times into the Tx of a packet
0x17	TxPausePkts	Number of PAUSE frames transmitted by a port
0x18	TxBroadcastPkts	Tx good broadcast packets (not including error broadcast or valid multi-cast packets)
0x19	TxMulticastPkts	Tx good multicast packets (not including error multicast packets or valid broadcast packets)
0x1A	TxUnicastPkts	Tx good unicast packets
0x1B	TxDeferred	Tx packets by a port for which the 1st Tx attempt is delayed due to the busy medium
0x1C	TxTotalCollision	Tx total collision, half duplex only
0x1D	TxExcessiveCollision	A count of frames for which Tx fails due to excessive collisions
0x1E	TxSingleCollision	Successfully Tx frames on a port for which Tx is inhibited by exactly one collision
0x1F	TxMultipleCollision	Successfully Tx frames on a port for which Tx is inhibited by more than one collision

**TABLE 4-15: FORMAT OF "ALL PORT DROPPED PACKET" MIB COUNTERS**

Bit	Name	R/W	Description	Default
30-16	Reserved	N/A	Reserved	N/A
15-0	Counter Value	RO	Counter Value	0

"All Port Dropped Packet" MIB counters are read using indirect memory access. The address offsets for these counters are shown in [Table 4-16](#).

**TABLE 4-16: "ALL PORT DROPPED PACKET" MIB COUNTERS INDIRECT MEMORY OFFSETS**

Offset	Counter Name	Description
0x100	Port 1 TX Drop Packets	TX packets dropped due to lack of resources
0x101	Port 2 TX Drop Packets	TX packets dropped due to lack of resources
0x102	Port 3 TX Drop Packets	TX packets dropped due to lack of resources
0x103	Port 1 RX Drop Packets	RX packets dropped due to lack of resources
0x104	Port 2 RX Drop Packets	RX packets dropped due to lack of resources
0x105	Port 3 RX Drop Packets	RX packets dropped due to lack of resources

Examples:

1. MIB Counter Read (Read port 1 “Rx64Octets” Counter)

Write to reg. 121 (0x79) with 0x1c // Read MIB counters selected

Write to reg. 122 (0x7A) with 0x0e // Trigger the read operation

Then

Read reg. 128 (0x80), overflow bit [31] // If bit 31 = 1, there was a counter overflow

valid bit [30] // If bit 30 = 0, restart (reread) from this register counter bits [29:24]

Read reg. 129 (0x81), counter bits [23:16]

Read reg. 130 (0x82), counter bits [15:8]

Read reg. 131 (0x83), counter bits [7:0]

2. MIB Counter Read (Read port 2 “Rx64Octets” Counter)

Write to reg. 121 (0x79) with 0x1c // Read MIB counter selected

Write to reg. 122 (0x7A) with 0x2e // Trigger the read operation

Then,

Read reg. 128 (0x80), overflow bit [31] // If bit 31 = 1, there was a counter overflow

valid bit [30] // If bit 30 = 0, restart (reread) from this register counter bits [29:24]

Read reg. 129 (0x81), counter bits [23:16]

Read reg. 130 (0x82), counter bits [15:8]

Read reg. 131 (0x83), counter bits [7:0]

3. MIB Counter Read (Read “Port1 TX Drop Packets” Counter)

Write to reg. 121 (0x79) with 0x1d // Read MIB counter selected

Write to reg. 122 (0x7A) with 0x00 // Trigger the read operation

Then

Read reg. 130 (0x82), counter bits [15:8]

Read reg. 131 (0x83), counter bits [7:0]

#### 4.9.1 ADDITIONAL MIB COUNTER INFORMATION

“Per Port” MIB counters are designed as “read clear.” These counters will be cleared after they are read.

“All Port Dropped Packet” MIB counters are not cleared after they are accessed and do not indicate overflow or validity; therefore, the application must keep track of overflow and valid conditions.

To read out all the counters, the best performance over the SPI bus is  $(160+3) \times 8 \times 200 = 260$  ms, where there are 160 registers, 3 overheads, 8 clocks per access, at 5 MHz. In the heaviest condition, the counters will overflow in 2 minutes. It is recommended that the software read all the counters at least every 30 seconds.

A high performance SPI master is also recommended to prevent counters overflow.

# KSZ8873MLL/FLL/RLL

## 5.0 OPERATIONAL CHARACTERISTICS

### 5.1 Absolute Maximum Ratings\*

Supply Voltage ( $V_{IN}$ ) ( $V_{DDA\_1.8}$ , $V_{DDC}$ )	-0.5V to +2.4V
( $V_{DDA\_3.3}$ , $V_{DDIO}$ )	-0.5V to +4.0V
Input Voltage	-0.5V to +4.0V
Output Voltage	-0.5V to +4.0V
Lead Temperature (soldering, 10s)	+260°C
Storage Temperature ( $T_S$ )	-55°C to +150°C
HBM ESD Rating	±3 kV

\*Exceeding the absolute maximum rating may damage the device. Stresses greater than the absolute maximum rating may cause permanent damage to the device. Operation of the device at these or any other conditions above those specified in the operating sections of this specification is not implied. Maximum conditions for extended periods may affect reliability.

### 5.2 Operating Ratings\*\*

Supply Voltage	
( $V_{DDA\_1.8}$ , $V_{DDC}$ )	+1.66V to +1.94V
( $V_{DDA\_3.3}$ )	+2.5V to +3.465V
( $V_{DDIO}$ )	+1.71V to +3.465V
Ambient Temperature ( $T_A$ )	
(Commercial)	0°C to +70°C
(Industrial)	-40°C to +85°C
Junction Temperature ( $T_J$ )	+125°C
Thermal Resistance LQFP (Note 5-1) ( $\Theta_{JA}$ )	+47.24°C/W
Thermal Resistance LQFP (Note 5-1) ( $\Theta_{JC}$ )	+19.37°C/W**The device is not guaranteed to function outside its operating ratings.

**Note 5-1** No heat spreader (HS) in this package.

**Note:** Do not drive input signals without power supplied to the device.

## 6.0 ELECTRICAL CHARACTERISTICS

$T_A = 25^\circ\text{C}$ . Specification is for packaged product only. Current consumption is for the single 3.3V supply device only and includes the 1.8V supply voltages ( $V_{DDA}$ ,  $V_{DDC}$ ) that are provided via power output pin 56 ( $V_{DDCO}$ ).

Each PHY port's transformer consumes an additional 45 mA at 3.3V for 100BASE-TX and 70 mA at 3.3V for 10BASE-T at full traffic.

**TABLE 6-1: ELECTRICAL CHARACTERISTICS**

Parameters	Symbol	Min.	Typ.	Max.	Units	Note
<b>100BASE-TX Operation (All Ports @ 100% Utilization)</b>						
100BASE-TX (analog core + digital core + transceiver + digital I/O)	$I_{DDXIO}$	—	115	—	mA	$V_{DDA\_3.3}$ , $V_{DDIO} = 3.3\text{V}$ (single power) Core power is provided from the internal 1.8V LDO with input voltage $3.3\text{V } V_{DDIO}$
100BASE-TX (3.3V Transceiver/digital I/O + 1.8V Analog/digital core)	$I_{DD} + I_C$	—	32 + 83	—	mA	$V_{DDA\_3.3}$ , $V_{DDIO} = 3.3\text{V}$ Analog and digital core power $V_{DDC}$ using an external 1.8V LDO
<b>10BASE-T Operation (All Ports @ 100% Utilization)</b>						
10BASE-T (analog core + digital core + transceiver + digital I/O)	$I_{DDXIO}$	—	85	—	mA	$V_{DDA\_3.3}$ , $V_{DDIO} = 3.3\text{V}$ Core power is provided from the internal 1.8V LDO with input voltage $V_{DDIO}$
10BASE-TX (3.3V Transceiver/digital I/O + 1.8V Analog/digital core)	$I_{DD} + I_C$	—	14 + 72	—	mA	$V_{DDA\_3.3}$ , $V_{DDIO} = 3.3\text{V}$ Analog and digital core power $V_{DDC}$ using an external 1.8V LDO
<b>Power Management Mode (with MII/RMII in Default PHY Mode)</b>						
Power Saving Mode	$I_{DD3}$	—	96	—	mA	$V_{DDA\_3.3}$ , $V_{DDIO} = 3.3\text{V}$ Unplug Port 1 and Port 2 Set Register 195 bit[1,0] = [1,1]
Soft Power Down Mode	$I_{DD4}$	—	5	—	mA	$V_{DDA\_3.3}$ , $V_{DDIO} = 3.3\text{V}$ Set Register 195 bit[1,0] = [1,0]
Energy Detect Mode	$I_{DD5}$	—	15	—	mA	$V_{DDA\_3.3}$ , $V_{DDIO} = 3.3\text{V}$ Unplug Port 1 and Port 2 Set Register 195 bit[7,0] = 0x05 with port 3 PHY mode and bypass mode.
<b>CMOS Inputs (<math>V_{DDIO} = 3.3\text{V}/2.5\text{V}/1.8\text{V}</math>)</b>						
Input High Voltage	$V_{IH}$	2.0/1.8/ 1.3	—	—	V	—
Input Low Voltage	$V_{IL}$	—	—	0.8/0.7/ 0.5	V	—
Input Current	$I_{IN}$	-10	—	10	$\mu\text{A}$	$V_{IN} = \text{GND} \sim V_{DDIO}$
<b>CMOS Outputs (<math>V_{DDIO} = 3.3\text{V}/2.5\text{V}/1.8\text{V}</math>)</b>						
Output High Voltage	$V_{OH}$	2.4/2.0/ 1.5	—	—	V	$I_{OH} = -8\text{ mA}$
Output Low Voltage	$V_{OL}$	—	—	0.4/0.4/ 0.3	V	$I_{OL} = 8\text{ mA}$
Output Tri-State Leakage	$ I_{OZ} $	—	—	10	$\mu\text{A}$	—
<b>100BASE-TX Transmit (measured differentially after 1:1 transformer)</b>						
Peak Differential Output Voltage	$V_O$	0.95	—	1.05	V	100 $\Omega$ termination across differential output

# KSZ8873MLL/FLL/RLL

**TABLE 6-1: ELECTRICAL CHARACTERISTICS (CONTINUED)**

Parameters	Symbol	Min.	Typ.	Max.	Units	Note
Output Voltage Imbalance	$V_{IMB}$	—	—	2	%	100 $\Omega$ termination across differential output
Rise/Fall Time	$t_r/t_f$	3	—	5	ns	—
Rise/Fall Time Imbalance	—	0	—	0.5	ns	—
Duty Cycle Distortion	—	—	—	$\pm 0.5$	ns	—
Overshoot	—	—	—	5	%	—
Output Jitter	—	—	0.7	1.4	ns	Peak-to-peak
<b>10BASE-T Receive</b>						
Squelch Threshold	$V_{SQ}$	—	400	—	mV	5 MHz square wave
<b>10BASE-T Transmit (measured differentially after 1:1 transformer)</b>						
Peak Differential Output Voltage	$V_P$	—	2.4	—	V	100 $\Omega$ termination across differential output
Output Jitter	—	—	1.4	11	ns	Peak-to-peak

## 7.0 TIMING SPECIFICATIONS

### 7.1 EEPROM Timing

**FIGURE 7-1: EEPROM INTERFACE INPUT TIMING DIAGRAM**

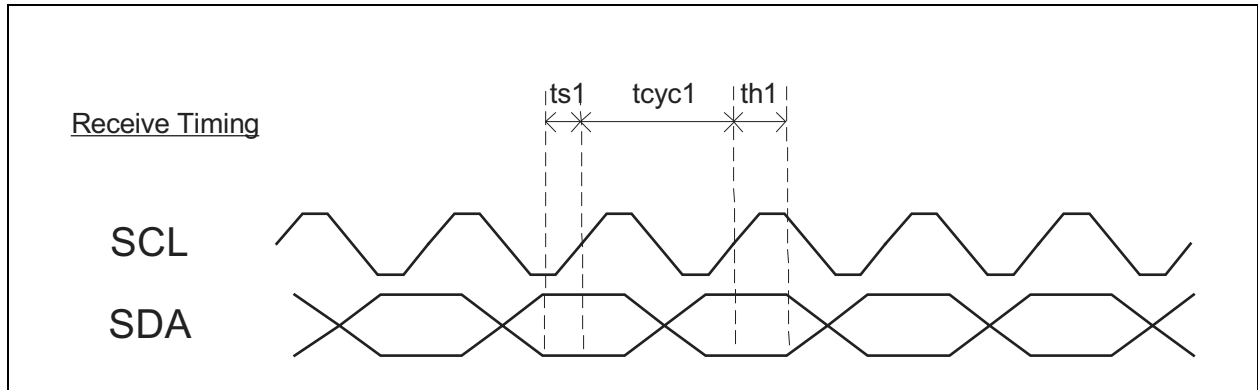

**FIGURE 7-2: EEPROM INTERFACE OUTPUT TIMING DIAGRAM**

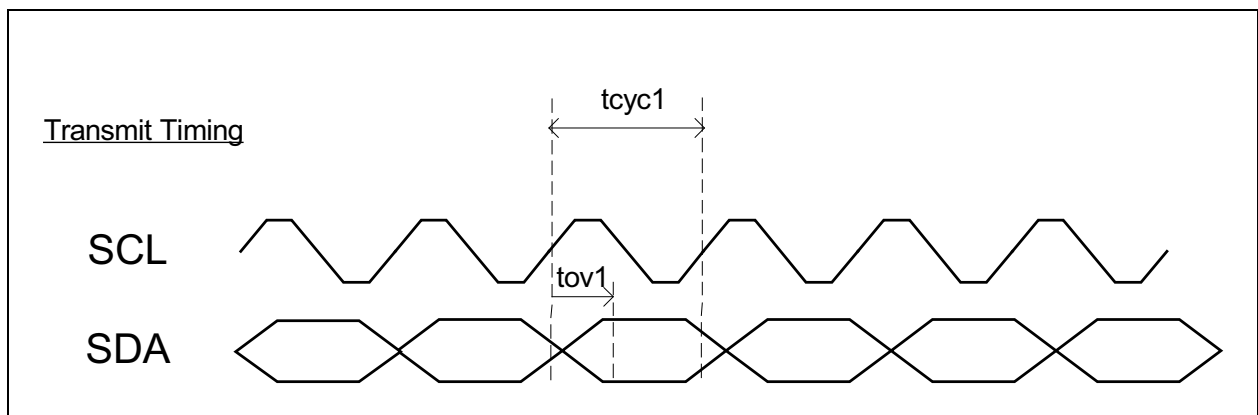

**TABLE 7-1: EEPROM TIMING PARAMETERS**

Symbol	Parameter	Min.	Typ.	Max.	Units
$t_{cyc1}$	Clock cycle	—	16384	—	ns
$t_{s1}$	Setup time	20	—	—	ns
$t_{h1}$	Hold time	20	—	—	ns
$t_{ov1}$	Output valid	4096	4112	4128	ns



# KSZ8873MLL/FLL/RLL

## 7.2 MAC Mode MII Timing

FIGURE 7-3: MAC MODE MII TIMING - DATA RECEIVED FROM MII

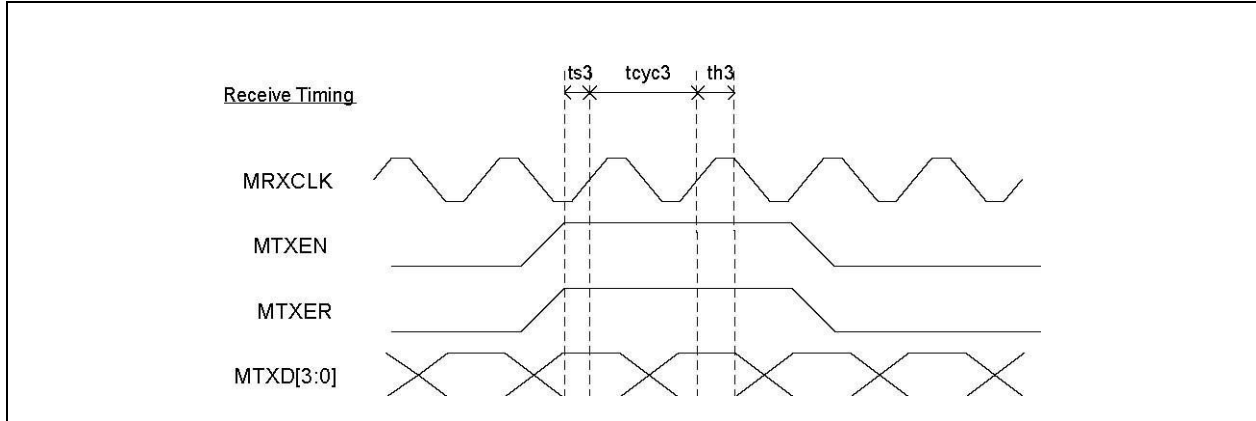

FIGURE 7-4: MAC MODE MII TIMING - DATA TRANSMITTED TO MII

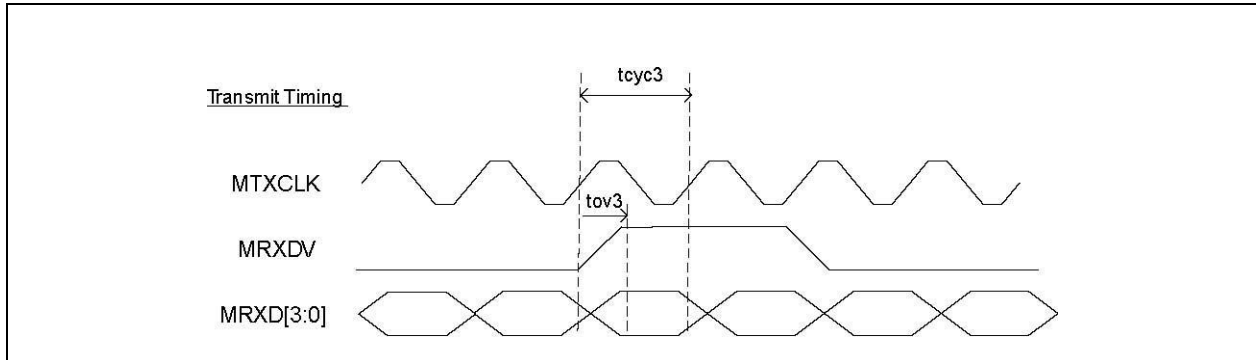
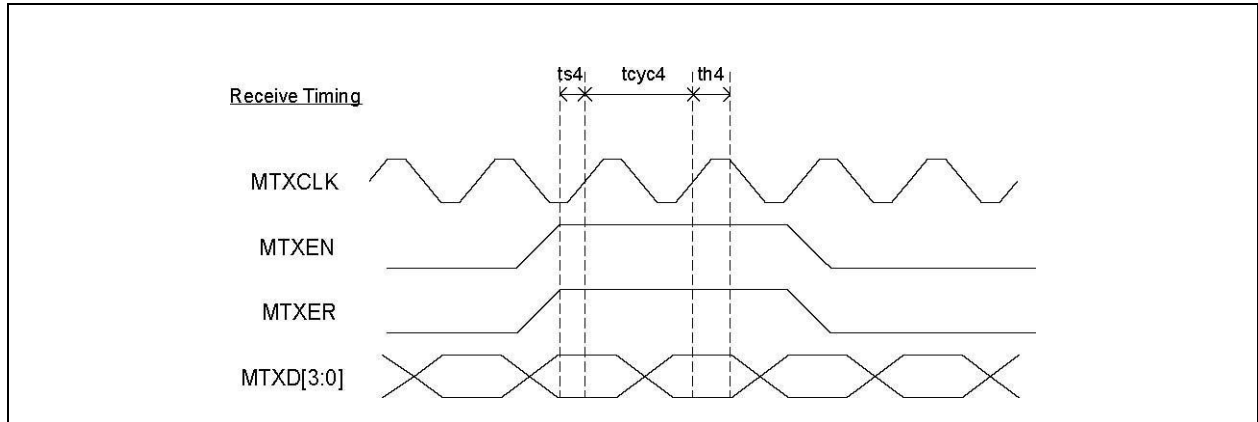

TABLE 7-2: MAC MODE MII TIMING PARAMETERS

Parameter	Description	Min.	Typ.	Max.	Units
$t_{cyc3}$	Clock cycle	—	400/40	—	ns
$t_{s3}$	Setup time	4	—	—	ns
$t_{h3}$	Hold time	2	—	—	ns
$t_{ov3}$	Output valid	7	11	16	ns

## 7.3 PHY Mode MII Timing

**FIGURE 7-5: PHY MODE MII TIMING - DATA RECEIVED FROM MII**



**FIGURE 7-6: PHY MODE MII TIMING - DATA TRANSMITTED TO MII**

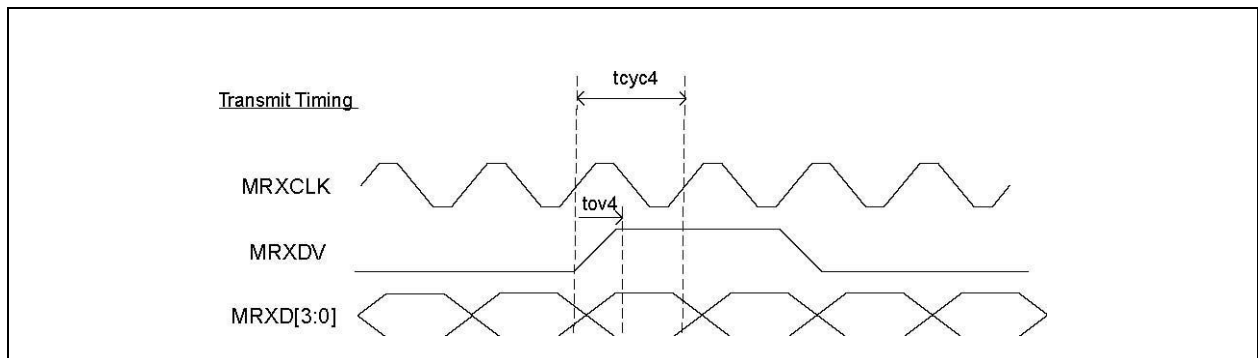

**TABLE 7-3: PHY MODE MII TIMING PARAMETERS**

Parameter	Description	Min.	Typ.	Max.	Units
$t_{cyc4}$	Clock cycle	—	400/40	—	ns
$t_{s4}$	Setup time	10	—	—	ns
$t_{h4}$	Hold time	0	—	—	ns
$t_{ov4}$	Output valid	18	—	19	ns

# KSZ8873MLL/FLL/RLL

## 7.4 RMII Timing

FIGURE 7-7: RMII TIMING - DATA RECEIVED FROM RMII

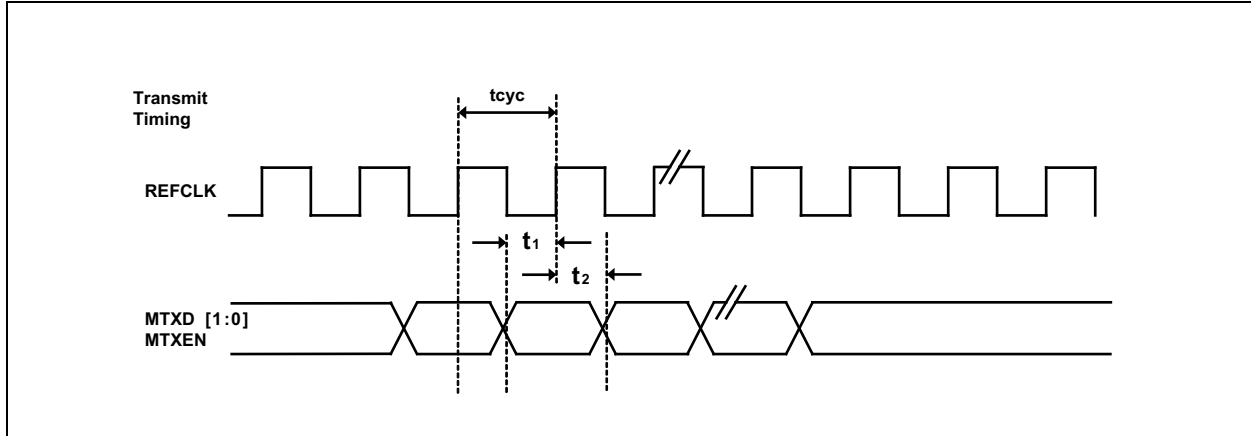

FIGURE 7-8: RMII TIMING - DATA TRANSMITTED TO RMII

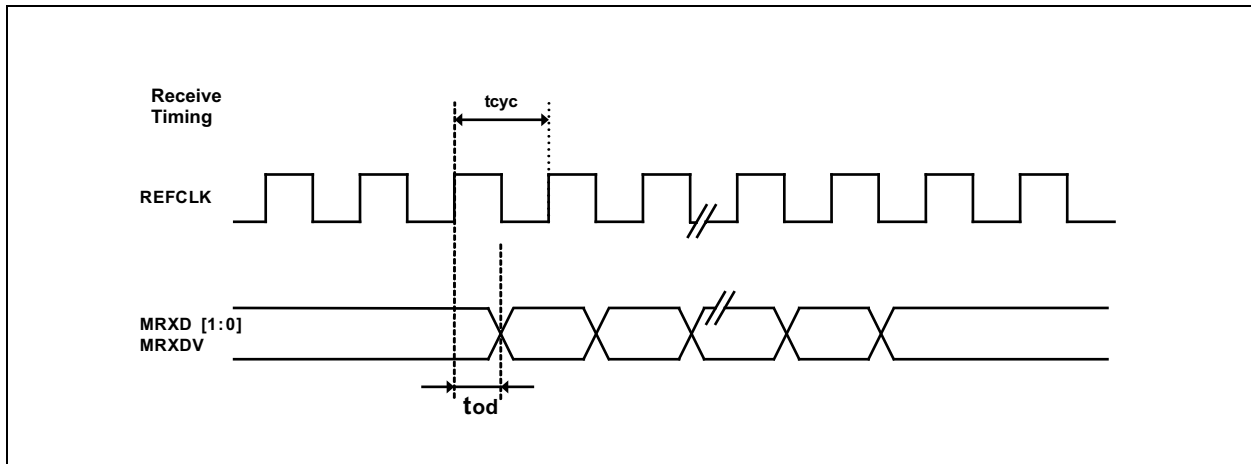
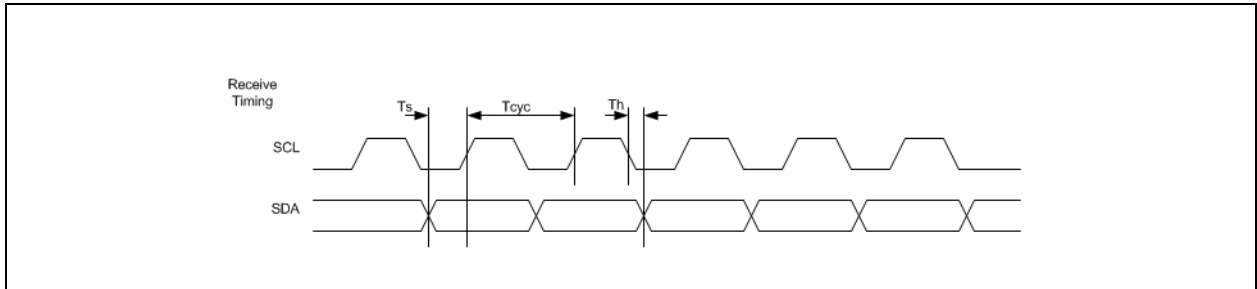

TABLE 7-4: RMII TIMING PARAMETERS

Parameter	Description	Min.	Typ.	Max.	Units
$t_{cyc}$	Clock cycle	—	20	—	ns
$t_1$	Setup time	4	—	—	ns
$t_2$	Hold time	2	—	—	ns
$t_{od}$	Output delay	6	—	16	ns

## 7.5 I<sup>2</sup>C Slave Mode Timing

**FIGURE 7-9: I<sup>2</sup>C INPUT TIMING**



**FIGURE 7-10: I<sup>2</sup>C START BIT TIMING**

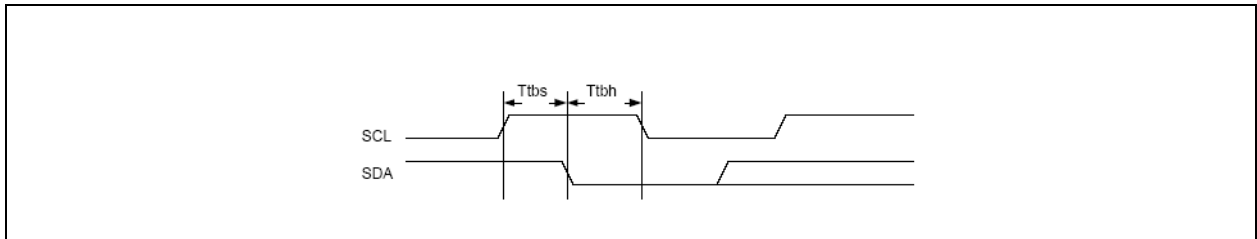

**FIGURE 7-11: I<sup>2</sup>C STOP BIT TIMING**

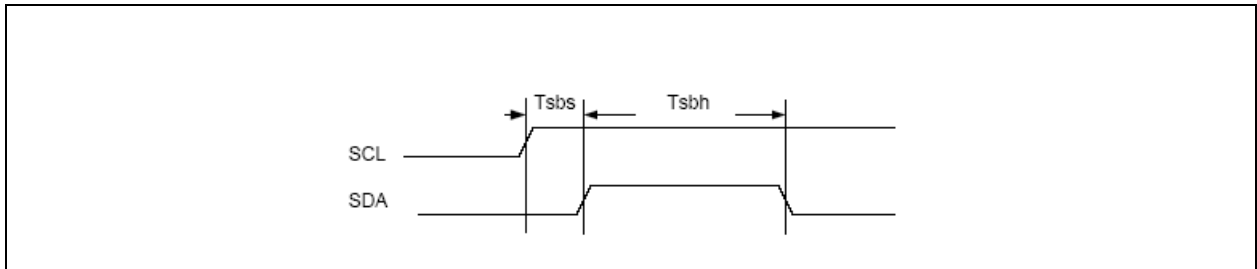

**FIGURE 7-12: I<sup>2</sup>C OUTPUT TIMING**

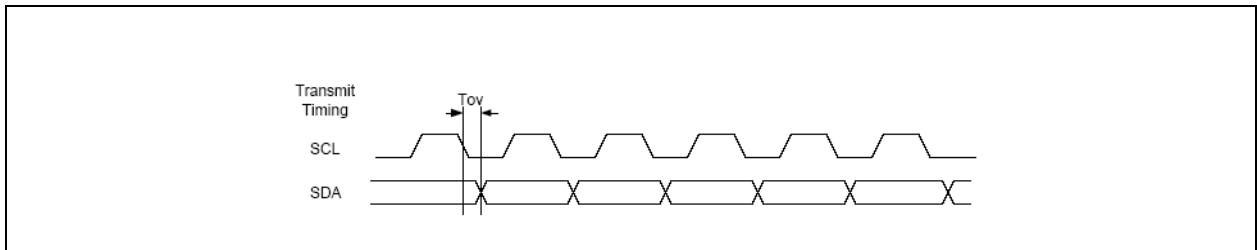

# KSZ8873MLL/FLL/RLL

**TABLE 7-5: I<sup>2</sup>C TIMING PARAMETERS**

Parameter	Description	Min.	Typ.	Max.	Units
$t_{cyc}$	Clock cycle	400	—	—	ns
$t_s$	Setup time	33	—	Half-Cycle	ns
$t_h$	Hold time	0	—	—	ns
$t_{tbs}$	Start bit setup time	33	—	—	ns
$t_{tbh}$	Start bit hold time	33	—	—	ns
$t_{sbs}$	Stop bit setup time	2	—	—	ns
$t_{sbh}$	Stop bit hold time	33	—	—	ns
$t_{ov}$	Output valid	64	—	96	ns

Note that data is only allowed to change during SCL low-time, except the start and stop bits.

## 7.6 SPI Input Timing

**FIGURE 7-13: SPI INPUT TIMING**

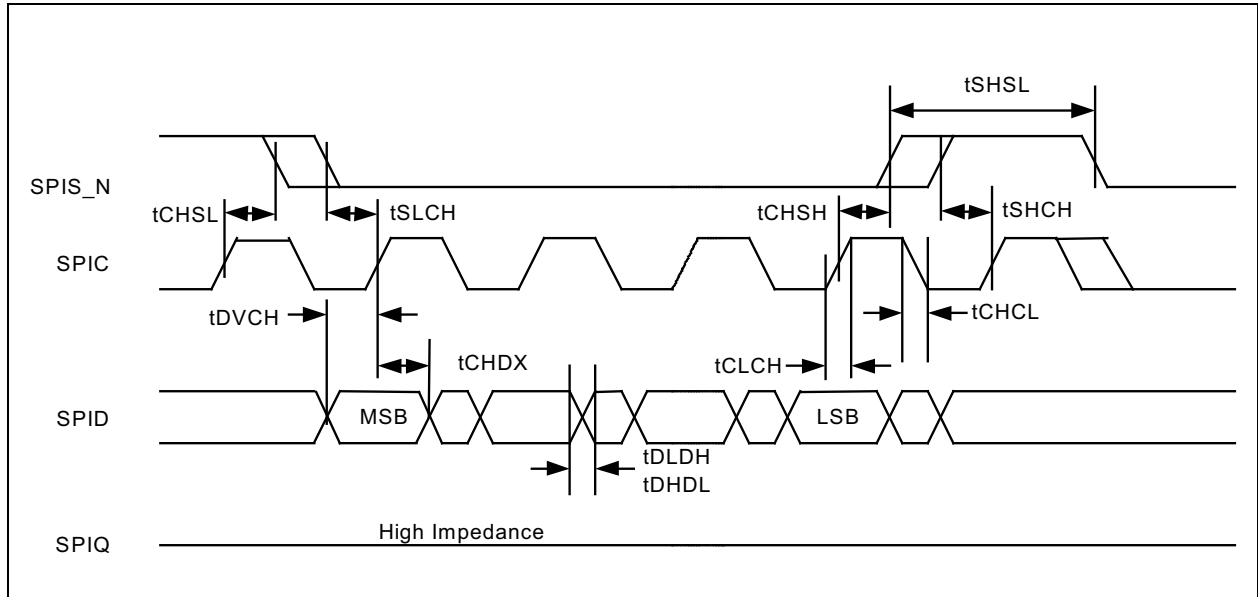

**TABLE 7-6: SPI INPUT TIMING PARAMETERS**

Timing Parameter	Description	Min.	Typ.	Max.	Units
$f_c$	Clock frequency	—	—	25	MHz
$t_{CHSL}$	SPISN inactive hold time	90	—	—	ns
$t_{SLCH}$	SPISN active setup time	90	—	—	ns
$t_{CHSH}$	SPISN active hold time	90	—	—	ns
$t_{SHCH}$	SPISN inactive setup time	90	—	—	ns
$t_{SHSL}$	SPISN deselect time	100	—	—	ns
$t_{DVCH}$	Data input setup time	20	—	—	ns
$t_{CHDX}$	Data input hold time	30	—	—	ns
$t_{CLCH}$	Clock rise time	—	—	1	$\mu$ s
$t_{CHCL}$	Clock fall time	—	—	1	$\mu$ s
$t_{DLDH}$	Data input rise time	—	—	1	$\mu$ s
$t_{DHDL}$	Data input fall time	—	—	1	$\mu$ s

# KSZ8873MLL/FLL/RLL

## 7.7 SPI Output Timing

FIGURE 7-14: SPI OUTPUT TIMING

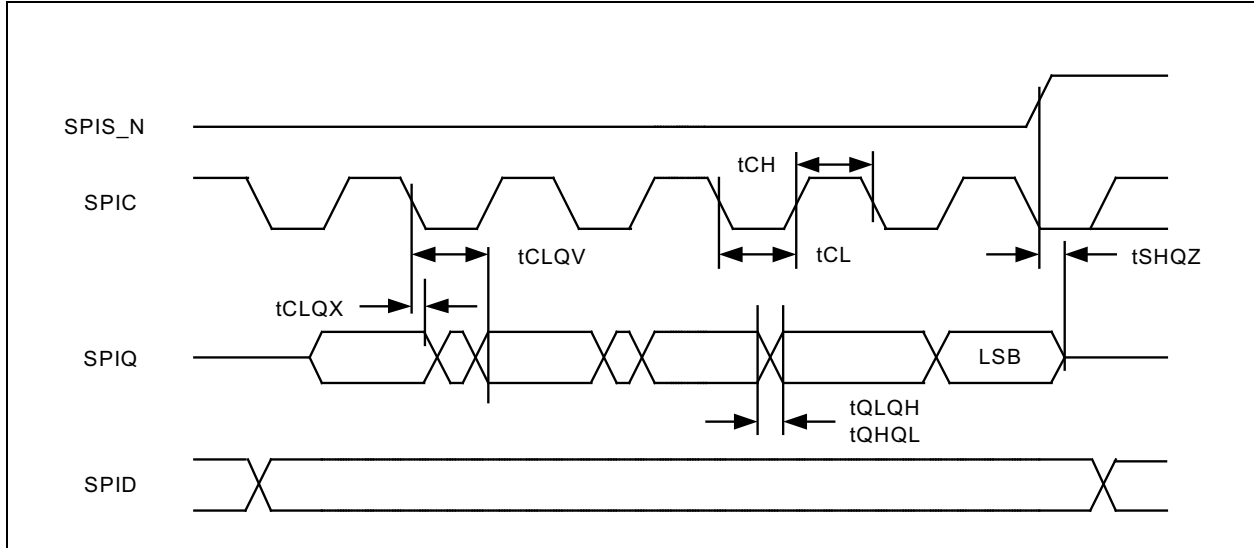

TABLE 7-7: SPI OUTPUT TIMING

Parameter	Description	Min.	Typ.	Max.	Units
$f_C$	Clock frequency	—	—	25	MHz
$t_{CLQX}$	SPIQ hold time	0	—	0	ns
$t_{CLQV}$	Clock low to SPIQ valid	—	—	60	ns
$t_{CH}$	Clock high time	90	—	—	ns
$t_{CL}$	Clock low time	90	—	—	ns
$t_{QLQH}$	SPIQ rise time	—	—	50	ns
$t_{QHQL}$	SPIQ fall time	—	—	50	ns
$t_{SHQZ}$	SPIQ disable time	—	—	100	ns

## 7.8 Auto-Negotiation Timing

FIGURE 7-15: AUTO-NEGOTIATION TIMING

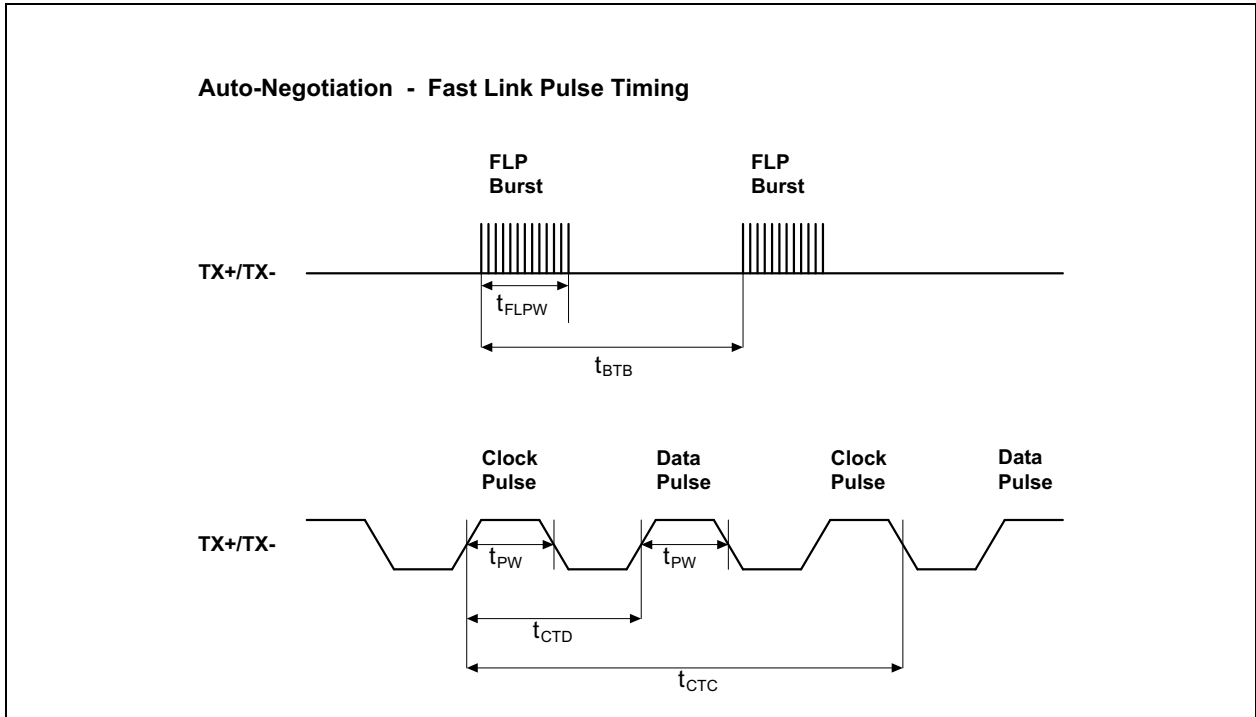

TABLE 7-8: AUTO-NEGOTIATION TIMING PARAMETERS

Parameter	Description	Min.	Typ.	Max.	Units
$t_{BTB}$	FLP burst to FLP burst	8	16	24	ms
$t_{FLPW}$	FLP burst width	—	2	—	ms
$t_{PW}$	Clock/Data pulse width	—	100	—	ns
$t_{CTD}$	Clock pulse to data pulse	55.5	64	69.5	$\mu$ s
$t_{CTC}$	Clock pulse to clock pulse	111	128	139	$\mu$ s
—	Number of clock/data pulses per burst	17	—	33	—



# KSZ8873MLL/FLL/RLL

## 7.9 MDC/MDIO Timing

FIGURE 7-16: MDC/MDIO TIMING

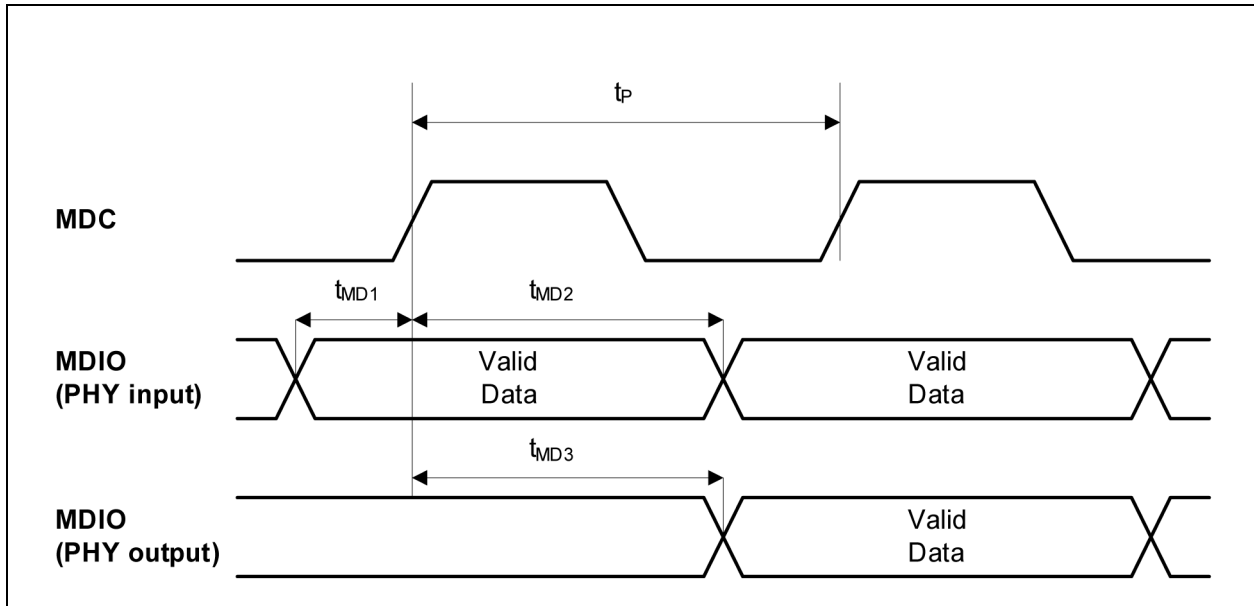

TABLE 7-9: MDC/MDIO TIMING PARAMETERS

Parameter	Description	Min.	Typ.	Max.	Units
$t_P$	MDC period	—	400	—	ns
$t_{MD1}$	MDIO (PHY Input) setup to rising edge of MDC	10	—	—	ns
$t_{MD2}$	MDIO (PHY Input) hold from rising edge of MDC	4	—	—	ns
$t_{MD3}$	MDIO (PHY Output) delay from rising edge of MDC	—	222	—	ns

## 7.10 Reset Timing

The KSZ8873MLL/FLL/RLL reset timing requirement is summarized in [Figure 7-17](#) and [Table 7-10](#).

**FIGURE 7-17: RESET TIMING**

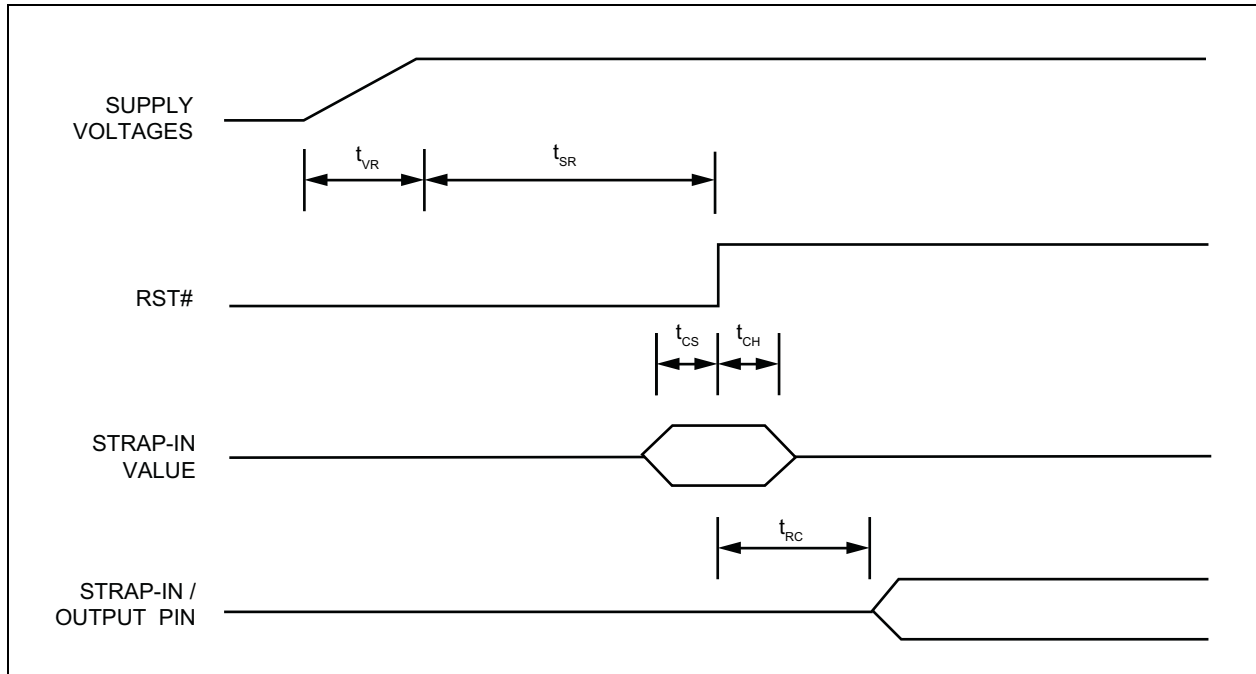

**TABLE 7-10: RESET TIMING PARAMETERS**

Parameter	Description	Min.	Typ.	Max.	Units
$t_{SR}$	Stable supply voltages to reset high	10	—	—	ms
$t_{CS}$	Configuration setup time	50	—	—	ns
$t_{CH}$	Configuration hold time	50	—	—	ns
$t_{RC}$	Reset to strap-in pin output	50	—	—	ns
$t_{VR}$	3.3V rise time	100	—	—	$\mu$ s

After the de-assertion of reset, wait a minimum of 100  $\mu$ s before starting programming on the managed interface (I<sup>2</sup>C slave, SPI slave, SMI, MIIM).

# KSZ8873MLL/FLL/RLL

## 8.0 RESET CIRCUIT

Figure 8-1 shows a reset circuit recommended for powering up the KSZ8873MLL/FLL/RLL if reset is triggered only by the power supply.

FIGURE 8-1: RECOMMENDED RESET CIRCUIT

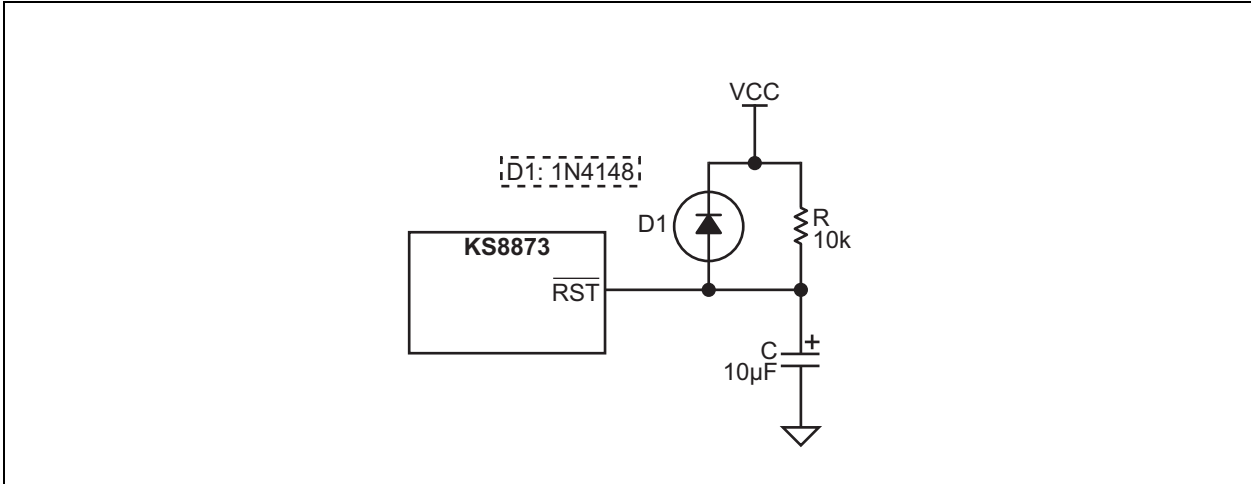
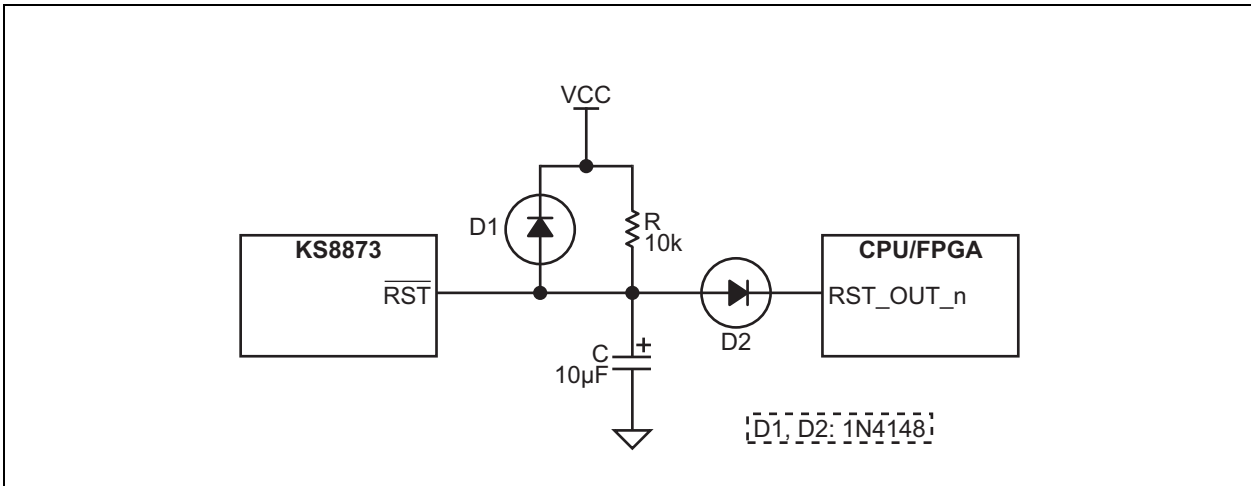

Figure 8-2 shows a reset circuit recommended for applications where reset is driven by another device (for example, the CPU or an FPGA). At power-on-reset, R, C, and D1 provide the necessary ramp rise time to reset the KSZ8873MLL/FLL/RLL device. The  $\text{RST\_OUT\_n}$  from the CPU/FPGA provides the warm reset after power-up.

FIGURE 8-2: RECOMMENDED RESET CIRCUIT FOR CPU/FPGA RESET OUTPUT



## 9.0 SELECTION OF ISOLATION TRANSFORMERS

A 1:1 isolation transformer is required at the line interface. Use one with integrated common-mode chokes for designs exceeding FCC requirements.

Table 9-1 lists recommended transformer characteristics.

**TABLE 9-1: TRANSFORMER SELECTION CRITERIA**

Parameter	Value	Test Conditions
Turns Ratio	1 CT : 1 CT	—
Open-Circuit Inductance (min.)	350 $\mu$ H	100 mV, 100 kHz, 8 mA
Leakage Inductance (max.)	0.4 $\mu$ H	1 MHz (min.)
Interwinding Capacitance (max.)	12 pF	—
D.C. Resistance (max.)	0.9 $\Omega$	—
Insertion Loss (max.)	-1.0 dB	0 MHz to 65 MHz
HIPOT (min.)	1500 V <sub>RMS</sub>	—

**TABLE 9-2: QUALIFIED SINGLE-PORT MAGNETICS**

Manufacturer	Part Number	Auto MDI-X
Bel Fuse	S558-5999-U7	Yes
Bel Fuse (MagJack)	SI-46001	Yes
Bel Fuse (MagJack)	SI-50170	Yes
Delta	LF8505	Yes
LanKom	LF-H41S	Yes
Pulse	H1102	Yes
Pulse (Low Cost)	H1260	Yes
Datatronic	NT79075	Yes
Transpower	HB726	Yes
YCL	LF-H41S	Yes
TDK (MagJack)	TLA-6T718	Yes

**TABLE 9-3: TYPICAL REFERENCE CRYSTAL CHARACTERISTICS**

Characteristic	Value
Frequency	25.00000 MHz
Frequency Tolerance (max.)	$\pm$ 50 ppm
Load Capacitance (max.)	20 pF
Series Resistance	40 $\Omega$

# KSZ8873MLL/FLL/RLL

## 10.0 PACKAGE OUTLINE

FIGURE 10-1: 64-LEAD LQFP 10 MM X 10 MM PACKAGE

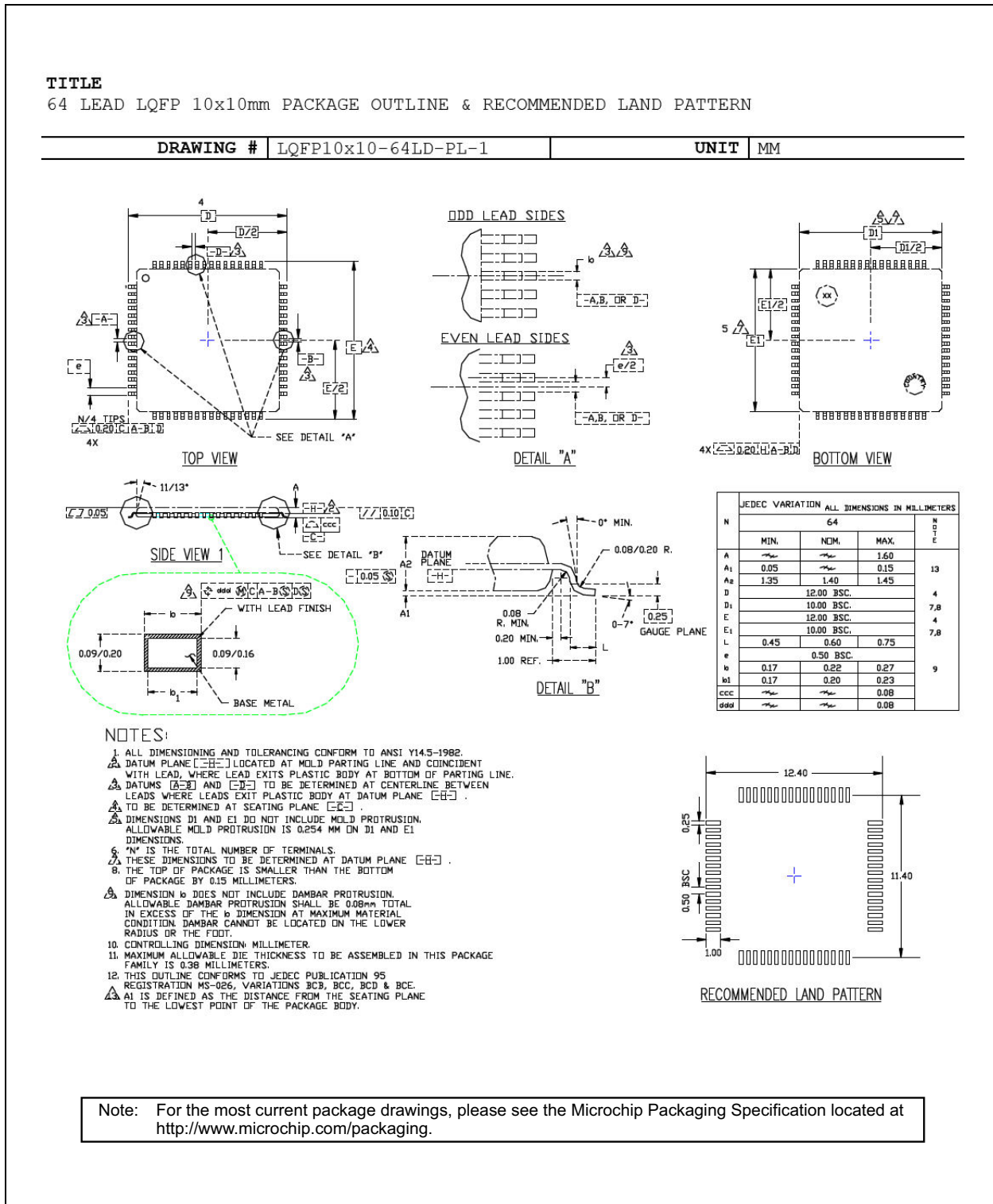

## APPENDIX A: DATA SHEET REVISION HISTORY

TABLE A-1: REVISION HISTORY

Revision	Section/Figure/Entry	Correction
DS00002348B (05-11-22)	<a href="#">Table 7-6, "SPI Input Timing Parameters"</a>	Updated SPI Input frequency from "5 MHz" to "25 MHz"
	<a href="#">Table 7-7, "SPI Output Timing"</a>	Updated SPI Output frequency from "5 MHz" to "25 MHz"
DS00002348A (1-30-17)	—	Converted Micrel data sheet KSZ8873MLL/FLL/RLL to Microchip DS00002348A. Minor text changes throughout.
	<a href="#">Table 4-7</a>	Updated the port register status 1 bit [0] description. Add power data for using external 1.8V LDO.
	<a href="#">Table 3-5</a>	Updated the note of the RMII interface operation

# KSZ8873MLL/FLL/RLL

---

---

## THE MICROCHIP WEB SITE

Microchip provides online support via our WWW site at [www.microchip.com](http://www.microchip.com). This web site is used as a means to make files and information easily available to customers. Accessible by using your favorite Internet browser, the web site contains the following information:

- **Product Support** – Data sheets and errata, application notes and sample programs, design resources, user's guides and hardware support documents, latest software releases and archived software
- **General Technical Support** – Frequently Asked Questions (FAQ), technical support requests, online discussion groups, Microchip consultant program member listing
- **Business of Microchip** – Product selector and ordering guides, latest Microchip press releases, listing of seminars and events, listings of Microchip sales offices, distributors and factory representatives

## CUSTOMER CHANGE NOTIFICATION SERVICE

Microchip's customer notification service helps keep customers current on Microchip products. Subscribers will receive e-mail notification whenever there are changes, updates, revisions or errata related to a specified product family or development tool of interest.

To register, access the Microchip web site at [www.microchip.com](http://www.microchip.com). Under "Support", click on "Customer Change Notification" and follow the registration instructions.

## CUSTOMER SUPPORT

Users of Microchip products can receive assistance through several channels:

- Distributor or Representative
- Local Sales Office
- Field Application Engineer (FAE)
- Technical Support

Customers should contact their distributor, representative or field application engineer (FAE) for support. Local sales offices are also available to help customers. A listing of sales offices and locations is included in the back of this document.

**Technical support is available through the web site at: <http://microchip.com/support>**

# KSZ8873MLL/FLL/RLL

## PRODUCT IDENTIFICATION SYSTEM

To order or obtain information, e.g., on pricing or delivery, refer to the factory or the listed sales office.

PART NO.	X	X	X	X	—	XX
Device	Interface	Package	Supply Voltage	Temperature	—	Media Type
<b>Device:</b>	KSZ8873					
<b>Interface:</b>	M = MII R = RMII F = Fibre					
<b>Package:</b>	L = 64-lead LQFP					
<b>Supply Voltage:</b>	L = Single 3.3V Supply					
<b>Temperature:</b>	blank = 0°C to +70°C (Commercial) I = -40°C to +85°C (Industrial) U or AM = -40°C to +85°C (Automotive Grade 3)					
<b>Media Type:</b>	blank = Tray TR = Tape & Reel					
<b>Examples:</b>						
a) KSZ8873MLL MII Interface 64-lead LQFP Single 3.3V Supply Commercial Temperature Tray						
b) KSZ8873MLLI MII Interface 64-lead LQFP Single 3.3V Supply Industrial Temperature Tray						
c) KSZ8873MLL AM MII Interface 64-lead LQFP Single 3.3V Supply Automotive Grade 3 Temperature Tray						
d) KSZ8873FLL Fibre Interface 64-lead LQFP Single 3.3V Supply Commercial Temperature Tray						
e) KSZ8873FLLI Fibre Interface 64-lead LQFP Single 3.3V Supply Industrial Temperature Tray						
f) KSZ8873RLL RMII Interface 64-lead LQFP Single 3.3V Supply Commercial Temperature Tray						
g) KSZ8873RLLI RMII Interface 64-lead LQFP Single 3.3V Supply Industrial Temperature Tray						
h) KSZ8873RLLU RMII Interface 64-lead LQFP Single 3.3V Supply Automotive Grade 3 Temperature Tray						
Note: Add -TR to any of the parts above to indicate the Tape & Reel option.						



# KSZ8873MLL/FLL/RLL

---

## Note the following details of the code protection feature on Microchip products:

- Microchip products meet the specifications contained in their particular Microchip Data Sheet.
- Microchip believes that its family of products is secure when used in the intended manner, within operating specifications, and under normal conditions.
- Microchip values and aggressively protects its intellectual property rights. Attempts to breach the code protection features of Microchip product is strictly prohibited and may violate the Digital Millennium Copyright Act.
- Neither Microchip nor any other semiconductor manufacturer can guarantee the security of its code. Code protection does not mean that we are guaranteeing the product is "unbreakable". Code protection is constantly evolving. Microchip is committed to continuously improving the code protection features of our products.

---

This publication and the information herein may be used only with Microchip products, including to design, test, and integrate Microchip products with your application. Use of this information in any other manner violates these terms. Information regarding device applications is provided only for your convenience and may be superseded by updates. It is your responsibility to ensure that your application meets with your specifications. Contact your local Microchip sales office for additional support or, obtain additional support at <https://www.microchip.com/en-us/support/design-help/client-support-services>.

THIS INFORMATION IS PROVIDED BY MICROCHIP "AS IS". MICROCHIP MAKES NO REPRESENTATIONS OR WARRANTIES OF ANY KIND WHETHER EXPRESS OR IMPLIED, WRITTEN OR ORAL, STATUTORY OR OTHERWISE, RELATED TO THE INFORMATION INCLUDING BUT NOT LIMITED TO ANY IMPLIED WARRANTIES OF NON-INFRINGEMENT, MERCHANTABILITY, AND FITNESS FOR A PARTICULAR PURPOSE, OR WARRANTIES RELATED TO ITS CONDITION, QUALITY, OR PERFORMANCE.

IN NO EVENT WILL MICROCHIP BE LIABLE FOR ANY INDIRECT, SPECIAL, PUNITIVE, INCIDENTAL, OR CONSEQUENTIAL LOSS, DAMAGE, COST, OR EXPENSE OF ANY KIND WHATSOEVER RELATED TO THE INFORMATION OR ITS USE, HOWEVER CAUSED, EVEN IF MICROCHIP HAS BEEN ADVISED OF THE POSSIBILITY OR THE DAMAGES ARE FORESEEABLE. TO THE FULLEST EXTENT ALLOWED BY LAW, MICROCHIP'S TOTAL LIABILITY ON ALL CLAIMS IN ANY WAY RELATED TO THE INFORMATION OR ITS USE WILL NOT EXCEED THE AMOUNT OF FEES, IF ANY, THAT YOU HAVE PAID DIRECTLY TO MICROCHIP FOR THE INFORMATION.

Use of Microchip devices in life support and/or safety applications is entirely at the buyer's risk, and the buyer agrees to defend, indemnify and hold harmless Microchip from any and all damages, claims, suits, or expenses resulting from such use. No licenses are conveyed, implicitly or otherwise, under any Microchip intellectual property rights unless otherwise stated.

## Trademarks

The Microchip name and logo, the Microchip logo, Adaptec, AnyRate, AVR, AVR logo, AVR Freaks, BesTime, BitCloud, CryptoMemory, CryptoRF, dsPIC, flexPWR, HELDO, IGLoo, JukeBlox, KeeLoq, Kleer, LANCheck, LinkMD, maXStylus, maXTouch, MediaLB, megaAVR, Microsemi, Microsemi logo, MOST, MOST logo, MPLAB, OptoLyzer, PIC, picoPower, PICSTART, PIC32 logo, PolarFire, Prochip Designer, QTouch, SAM-BA, SenGenuity, SpyNIC, SST, SST Logo, SuperFlash, Symmetricom, SyncServer, Tachyon, TimeSource, tinyAVR, UNI/O, Vectron, and XMEGA are registered trademarks of Microchip Technology Incorporated in the U.S.A. and other countries.

AgileSwitch, APT, ClockWorks, The Embedded Control Solutions Company, EtherSynch, Flashtec, Hyper Speed Control, HyperLight Load, IntelliMOS, Libero, motorBench, mTouch, Powermite 3, Precision Edge, ProASIC, ProASIC Plus, ProASIC Plus logo, Quiet-Wire, SmartFusion, SyncWorld, Temux, TimeCesium, TimeHub, TimePictra, TimeProvider, TrueTime, WinPath, and ZL are registered trademarks of Microchip Technology Incorporated in the U.S.A.

Adjacent Key Suppression, AKS, Analog-for-the-Digital Age, Any Capacitor, AnyIn, AnyOut, Augmented Switching, BlueSky, BodyCom, CodeGuard, CryptoAuthentication, CryptoAutomotive, CryptoCompanion, CryptoController, dsPICDEM, dsPICDEM.net, Dynamic Average Matching, DAM, ECAN, Espresso T1S, EtherGREEN, GridTime, IdealBridge, In-Circuit Serial Programming, ICSP, INICnet, Intelligent Paralleling, Inter-Chip Connectivity, JitterBlocker, Knob-on-Display, maxCrypto, maxView, memBrain, Mindi, MiWi, MPASM, MPF, MPLAB Certified logo, MPLIB, MPLINK, MultiTRAK, NetDetach, NVMe Express, NVMe, Omniscient Code Generation, PICDEM, PICDEM.net, PICkit, PICtail, PowerSmart, PureSilicon, QMatrix, REAL ICE, Ripple Blocker, RTAX, RTG4, SAM-ICE, Serial Quad I/O, simpleMAP, SimpliPHY, SmartBuffer, SmartHLS, SMART-I.S., storClad, SQL, SuperSwitcher, SuperSwitcher II, Switchtec, SynchroPHY, Total Endurance, TSHARC, USBCheck, VariSense, VectorBlox, VeriPHY, ViewSpan, WiperLock, XpressConnect, and ZENA are trademarks of Microchip Technology Incorporated in the U.S.A. and other countries.

SQTP is a service mark of Microchip Technology Incorporated in the U.S.A.

The Adaptec logo, Frequency on Demand, Silicon Storage Technology, Symmcom, and Trusted Time are registered trademarks of Microchip Technology Inc. in other countries.

GestIC is a registered trademark of Microchip Technology Germany II GmbH & Co. KG, a subsidiary of Microchip Technology Inc., in other countries.

All other trademarks mentioned herein are property of their respective companies.

© 2022, Microchip Technology Incorporated and its subsidiaries.

All Rights Reserved.

ISBN: 9781668304242

For information regarding Microchip's Quality Management Systems, please visit [www.microchip.com/quality](http://www.microchip.com/quality).



---

---

## Worldwide Sales and Service

---

---

### AMERICAS

**Corporate Office**  
2355 West Chandler Blvd.  
Chandler, AZ 85224-6199  
Tel: 480-792-7200  
Fax: 480-792-7277  
Technical Support:  
[http://www.microchip.com/  
support](http://www.microchip.com/support)  
Web Address:  
[www.microchip.com](http://www.microchip.com)

**Atlanta**  
Duluth, GA  
Tel: 678-957-9614  
Fax: 678-957-1455

**Austin, TX**  
Tel: 512-257-3370

**Boston**  
Westborough, MA  
Tel: 774-760-0087  
Fax: 774-760-0088

**Chicago**  
Itasca, IL  
Tel: 630-285-0071  
Fax: 630-285-0075

**Dallas**  
Addison, TX  
Tel: 972-818-7423  
Fax: 972-818-2924

**Detroit**  
Novi, MI  
Tel: 248-848-4000

**Houston, TX**  
Tel: 281-894-5983

**Indianapolis**  
Noblesville, IN  
Tel: 317-773-8323  
Fax: 317-773-5453  
Tel: 317-536-2380

**Los Angeles**  
Mission Viejo, CA  
Tel: 949-462-9523  
Fax: 949-462-9608  
Tel: 951-273-7800

**Raleigh, NC**  
Tel: 919-844-7510

**New York, NY**  
Tel: 631-435-6000

**San Jose, CA**  
Tel: 408-735-9110  
Tel: 408-436-4270

**Canada - Toronto**  
Tel: 905-695-1980  
Fax: 905-695-2078

### ASIA/PACIFIC

**Australia - Sydney**  
Tel: 61-2-9868-6733

**China - Beijing**  
Tel: 86-10-8569-7000

**China - Chengdu**  
Tel: 86-28-8665-5511

**China - Chongqing**  
Tel: 86-23-8980-9588

**China - Dongguan**  
Tel: 86-769-8702-9880

**China - Guangzhou**  
Tel: 86-20-8755-8029

**China - Hangzhou**  
Tel: 86-571-8792-8115

**China - Hong Kong SAR**  
Tel: 852-2943-5100

**China - Nanjing**  
Tel: 86-25-8473-2460

**China - Qingdao**  
Tel: 86-532-8502-7355

**China - Shanghai**  
Tel: 86-21-3326-8000

**China - Shenyang**  
Tel: 86-24-2334-2829

**China - Shenzhen**  
Tel: 86-755-8864-2200

**China - Suzhou**  
Tel: 86-186-6233-1526

**China - Wuhan**  
Tel: 86-27-5980-5300

**China - Xian**  
Tel: 86-29-8833-7252

**China - Xiamen**  
Tel: 86-592-2388138

**China - Zhuhai**  
Tel: 86-756-3210040

### ASIA/PACIFIC

**India - Bangalore**  
Tel: 91-80-3090-4444

**India - New Delhi**  
Tel: 91-11-4160-8631

**India - Pune**  
Tel: 91-20-4121-0141

**Japan - Osaka**  
Tel: 81-6-6152-7160

**Japan - Tokyo**  
Tel: 81-3-6880-3770

**Korea - Daegu**  
Tel: 82-53-744-4301

**Korea - Seoul**  
Tel: 82-2-554-7200

**Malaysia - Kuala Lumpur**  
Tel: 60-3-7651-7906

**Malaysia - Penang**  
Tel: 60-4-227-8870

**Philippines - Manila**  
Tel: 63-2-634-9065

**Singapore**  
Tel: 65-6334-8870

**Taiwan - Hsin Chu**  
Tel: 886-3-577-8366

**Taiwan - Kaohsiung**  
Tel: 886-7-213-7830

**Taiwan - Taipei**  
Tel: 886-2-2508-8600

**Thailand - Bangkok**  
Tel: 66-2-694-1351

**Vietnam - Ho Chi Minh**  
Tel: 84-28-5448-2100

### EUROPE

**Austria - Wels**  
Tel: 43-7242-2244-39  
Fax: 43-7242-2244-393

**Denmark - Copenhagen**  
Tel: 45-4485-5910  
Fax: 45-4485-2829

**Finland - Espoo**  
Tel: 358-9-4520-820

**France - Paris**  
Tel: 33-1-69-53-63-20  
Fax: 33-1-69-30-90-79

**Germany - Garching**  
Tel: 49-8931-9700

**Germany - Haan**  
Tel: 49-2129-3766400

**Germany - Heilbronn**  
Tel: 49-7131-72400

**Germany - Karlsruhe**  
Tel: 49-721-625370

**Germany - Munich**  
Tel: 49-89-627-144-0  
Fax: 49-89-627-144-44

**Germany - Rosenheim**  
Tel: 49-8031-354-560

**Israel - Ra'anana**  
Tel: 972-9-744-7705

**Italy - Milan**  
Tel: 39-0331-742611  
Fax: 39-0331-466781

**Italy - Padova**  
Tel: 39-049-7625286

**Netherlands - Drunen**  
Tel: 31-416-690399  
Fax: 31-416-690340

**Norway - Trondheim**  
Tel: 47-7288-4388

**Poland - Warsaw**  
Tel: 48-22-3325737

**Romania - Bucharest**  
Tel: 40-21-407-87-50

**Spain - Madrid**  
Tel: 34-91-708-08-90  
Fax: 34-91-708-08-91

**Sweden - Gothenberg**  
Tel: 46-31-704-60-40

**Sweden - Stockholm**  
Tel: 46-8-5090-4654

**UK - Wokingham**  
Tel: 44-118-921-5800  
Fax: 44-118-921-5820