



Product Change Notification / SYST-18HHML301

Date:

19-May-2022

Product Category:

Switching Regulators

PCN Type:

Document Change

Notification Subject:

Data Sheet - MIC2619 - 1.2MHz PWM Boost Converter with OVP Revision

Affected CPNs:

[SYST-18HHML301_Affected_CPN_05192022.pdf](#)

[SYST-18HHML301_Affected_CPN_05192022.csv](#)

Notification Text:

SYST-18HHML301

Microchip has released a new Product Documents for the MIC2619 - 1.2MHz PWM Boost Converter with OVP of devices. If you are using one of these devices please read the document located at [MIC2619 - 1.2MHz PWM Boost Converter with OVP](#).

Notification Status: Final

Description of Change: Revision includes:

1. Converted Micrel document MIC2619 to Microchip data sheet DS20006545A.
2. Minor text change throughout.
3. Removed the Evaluation Board Schematic and Recommended Layout sections as those appear

in the MIC2619 User's Guide.

Impacts to Data Sheet: See above details.

Reason for Change: To Improve Productivity

Change Implementation Status: Complete

Date Document Changes Effective: 19 May 2022

NOTE: Please be advised that this is a change to the document only the product has not been changed.

Markings to Distinguish Revised from Unrevised Devices: N/A

Attachments:

MIC2619 - 1.2MHz PWM Boost Converter with OVP

Please contact your local **Microchip sales office** with questions or concerns regarding this notification.

Terms and Conditions:

If you wish to receive Microchip PCNs via email please register for our PCN email service at our **PCN home page** select register then fill in the required fields. You will find instructions about registering for Microchips PCN email service in the **PCN FAQ** section.

If you wish to change your PCN profile, including opt out, please go to the **PCN home page** select login and sign into your myMicrochip account. Select a profile option from the left navigation bar and make the applicable selections.

Affected Catalog Part Numbers (CPN)

MIC2619YD6-TR

1.2 MHz PWM Boost Converter with OVP

Features

- 2.8V to 6.5V Input Voltage
- 350 mA Switch Current
- Output Voltage up to 35V
- 1.2 MHz PWM Operation
- 1.265V Feedback Voltage
- Programmable Overvoltage Protection (OVP)
- <1% Line Regulation
- <1 μ A Shutdown Current
- Overtemperature Protection
- Undervoltage Lock Out (UVLO)
- Low Profile Thin SOT-23-6 Package
- -40°C to $+125^{\circ}\text{C}$ Junction Temperature Range

Applications

- Bias Supply Applications:
 - Tuner Varactor Bias
 - High Voltage Bias Supplies
 - Avalanche Photo Diode
 - High Voltage Display Bias
- DSL/Broadband Applications
- Constant Current Power Supplies

General Description

The MIC2619 is a 1.2 MHz pulse width modulated (PWM) step-up switching regulator that is optimized for low power, high output voltage applications. With a maximum output voltage of 35V and a switch current of over 350 mA, the MIC2619 can easily supply most high voltage bias applications, such as TV tuners.

The MIC2619 implements a constant frequency 1.2 MHz PWM current-mode control scheme. The high frequency PWM operation saves board space by reducing external component sizes. The additional benefit of the constant frequency PWM control scheme, as opposed to variable frequency control schemes, is lower output noise and smaller input ripple injected back to the battery source. The MIC2619 has programmable overvoltage protection to ensure output protection in case of fault condition.

The MIC2619 is available in a low profile Thin SOT-23 6-lead package. The MIC2619 has a junction temperature range of -40°C to $+125^{\circ}\text{C}$.

Package Type

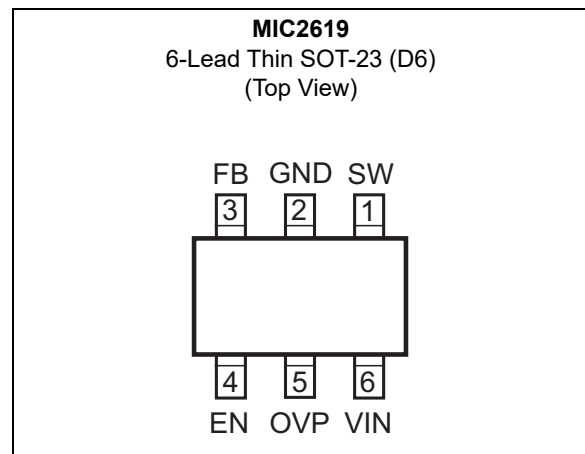

MIC2619

Typical Application Circuit

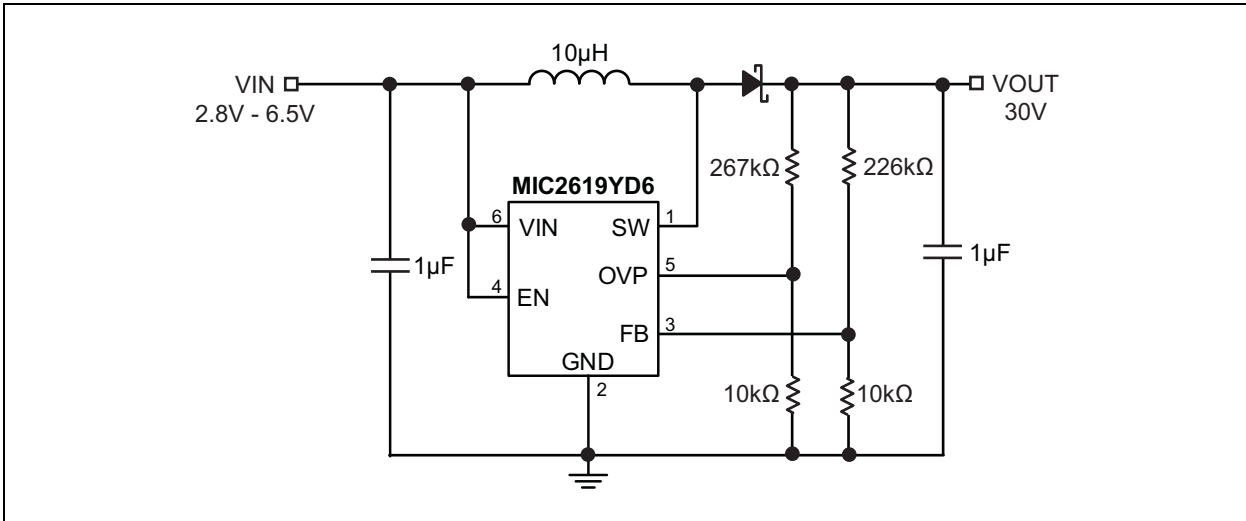

Functional Block Diagram

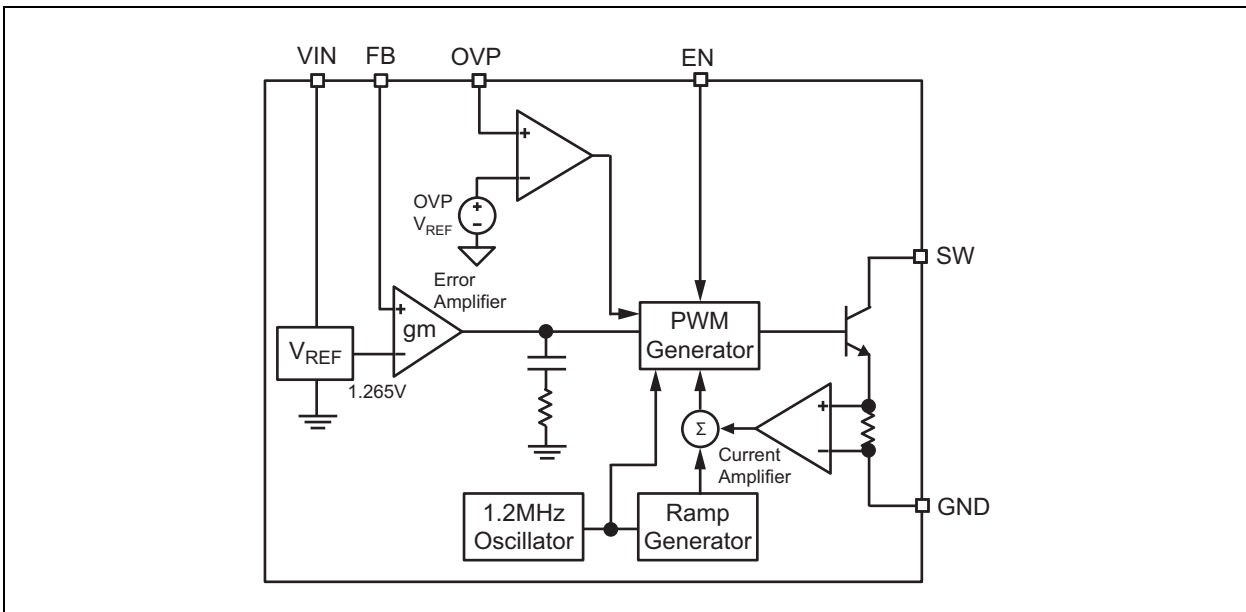

1.0 ELECTRICAL CHARACTERISTICS

Absolute Maximum Ratings †

Supply Voltage (V_{IN})	+7V
Switch Voltage (V_{SW})	-0.3V to +40V
Enable Pin Voltage (V_{EN})	-0.3V to V_{IN}
Feedback Voltage (V_{FB} , V_{OVP})	+6V
ESD Rating (Note 1)	2 kV

Operating Ratings ‡

Supply Voltage (V_{IN})	+2.8V to +6.5V
Output Voltage (V_{OUT})	V_{IN} to +35V

† **Notice:** Stresses above those listed under “Absolute Maximum Ratings” may cause permanent damage to the device. This is a stress rating only and functional operation of the device at those or any other conditions above those indicated in the operational sections of this specification is not intended. Exposure to maximum rating conditions for extended periods may affect device reliability.

‡ **Notice:** The device is not guaranteed to function outside its operating ratings.

Note 1: Devices are inherently ESD sensitive. Handling precautions required. Human body model: 1.5 k Ω in series with 100 pF.

ELECTRICAL CHARACTERISTICS

Electrical Characteristics: $T_A = +25^\circ\text{C}$, $V_{IN} = V_{EN} = 3.6\text{V}$, $V_{OUT} = 10\text{V}$, $I_{OUT} = 10\text{ mA}$, unless otherwise noted.

Bold values valid for $-40^\circ\text{C} \leq T_J \leq 125^\circ\text{C}$. (Note 1)

Parameter	Symbol	Min.	Typ.	Max.	Units	Conditions
Supply Voltage Range	V_{IN}	2.8	—	6.5	V	—
Undervoltage Lockout	UVLO	1.8	2.1	2.4	V	—
Quiescent Current	I_Q	—	2.1	5	mA	$V_{FB} > 1.265\text{V}$, (not switching)
Shutdown Current	I_{SD}	—	0.04	1	μA	$V_{EN} = 0\text{V}$
Feedback Voltage	V_{FB}	1.227	1.265	1.303	V	—
Feedback Input Current	I_{FB}	—	-450	—	nA	$V_{FB} > 1.265\text{V}$
Line Regulation		—	0.2	1	%	$2.8\text{V} \leq V_{IN} \leq 6.5\text{V}$
Load Regulation		—	0.3	—	%	$5\text{ mA} \leq I_{OUT} \leq 20\text{ mA}$
Maximum Duty Cycle	—	85	90	—	%	—
Switch Current Limit	I_{SW}	350	—	—	mA	$V_{IN} = 3.6\text{V}$ (Note 2)
Switch Saturation Voltage	V_{SW}	—	400	—	mV	$V_{IN} = 3.6\text{V}$, $I_{SW} = 300\text{ mA}$
Switch Leakage Current		—	0.01	1	μA	$V_{EN} = 0\text{V}$, $V_{SW} = 10\text{V}$
Enable Threshold		1.5	—	—	V	Turn On
		—	—	0.4		Turn Off
Enable Pin Current	I_{EN}	—	14	40	μA	$V_{EN} = 6.5\text{V}$
Oscillator Frequency	f_O	—	1.2	—	MHz	—
Overvoltage Protection	V_{OVP}	1.202	1.265	1.328	V	—
OVP Input Current	I_{OVP}	—	-200	—	nA	$V_{OVP} = 1.265\text{V}$
Overtemperature Threshold Shutdown		—	150	—	$^\circ\text{C}$	—
		—	10	—	$^\circ\text{C}$	Hysteresis

Note 1: Specification for packaged product only.

2: Ensured by design.

MIC2619

TEMPERATURE SPECIFICATIONS (Note 1)

Parameters	Sym.	Min.	Typ.	Max.	Units	Conditions
Temperature Ranges						
Junction Temperature Range	T_J	-40	—	+125	°C	—
Ambient Storage Temperature Range	T_S	-65	—	+150	°C	Soldering, 5 sec.
Package Thermal Resistance						
Thermal Resistance, TSOT 6-Ld	θ_{JA}	—	177	—	°C/W	—

Note 1: The maximum allowable power dissipation is a function of ambient temperature, the maximum allowable junction temperature and the thermal resistance from junction to air (i.e., T_A , T_J , θ_{JA}). Exceeding the maximum allowable power dissipation will cause the device operating junction temperature to exceed the maximum +125°C rating. Sustained junction temperatures above +125°C can impact the device reliability.

2.0 TYPICAL PERFORMANCE CURVES

Note: The graphs and tables provided following this note are a statistical summary based on a limited number of samples and are provided for informational purposes only. The performance characteristics listed herein are not tested or guaranteed. In some graphs or tables, the data presented may be outside the specified operating range (e.g., outside specified power supply range) and therefore outside the warranted range.

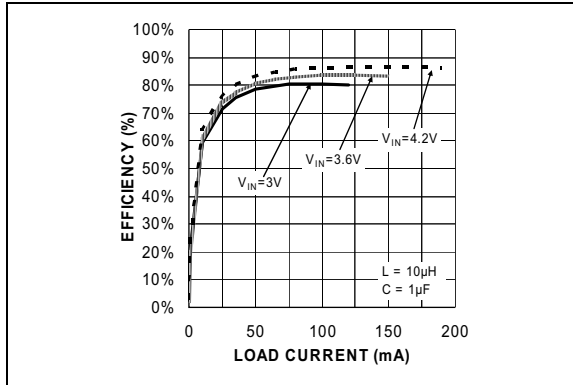

FIGURE 2-1: Efficiency $V_{OUT} = 5V$.

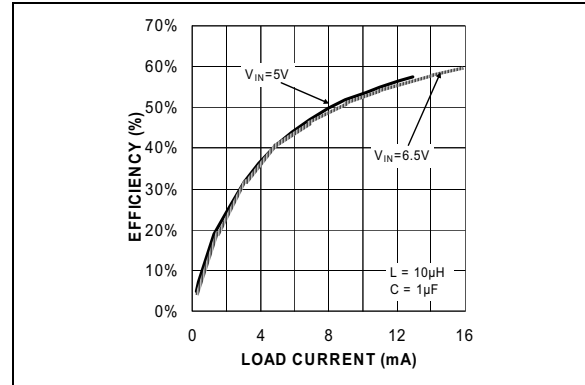

FIGURE 2-4: Efficiency $V_{OUT} = 35V$.

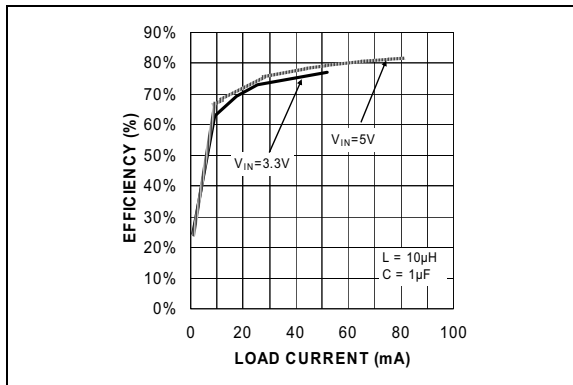

FIGURE 2-2: Efficiency $V_{OUT} = 10V$.

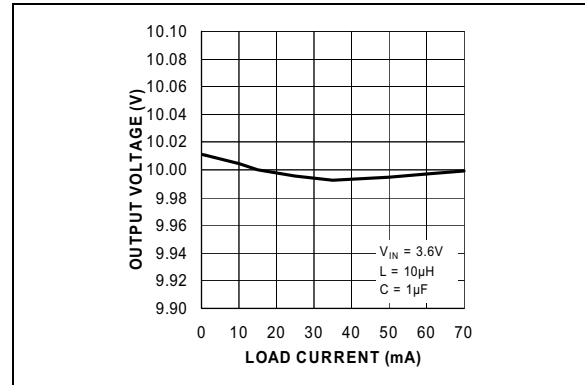

FIGURE 2-5: Load Regulation ($V_{OUT} = 10V$).

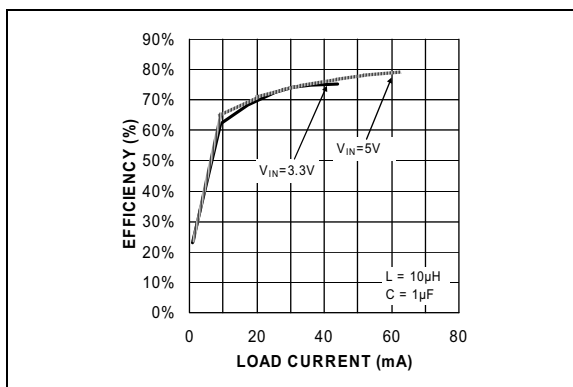

FIGURE 2-3: Efficiency $V_{OUT} = 12V$.

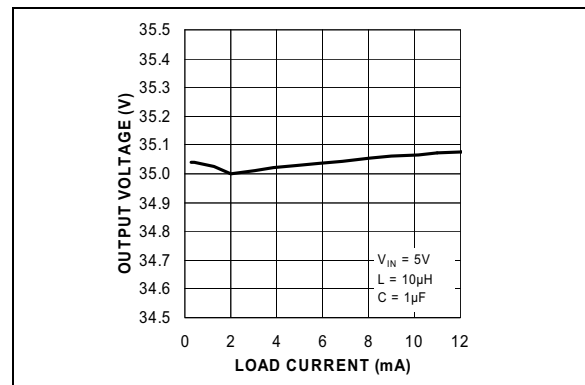

FIGURE 2-6: Load Regulation ($V_{OUT} = 35V$).

MIC2619

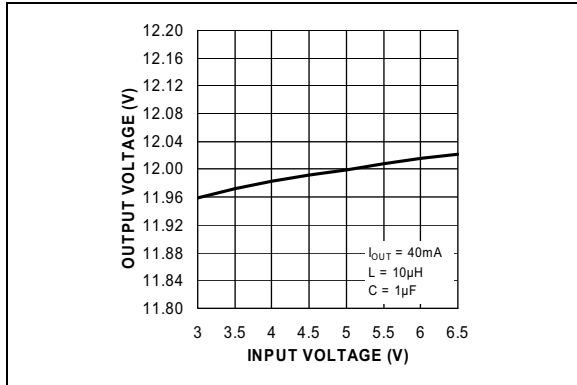

FIGURE 2-7: Line Regulation ($V_{OUT} = 12V$).

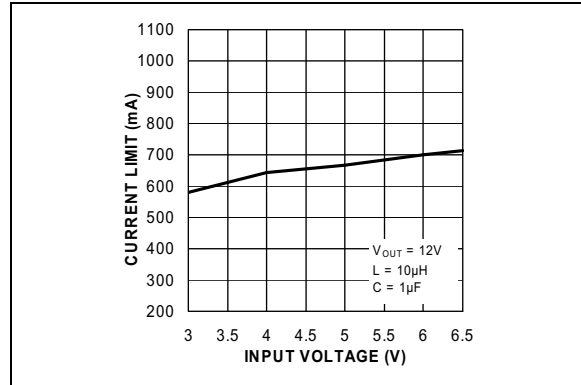

FIGURE 2-10: Switch Current Limit vs. Input Voltage.

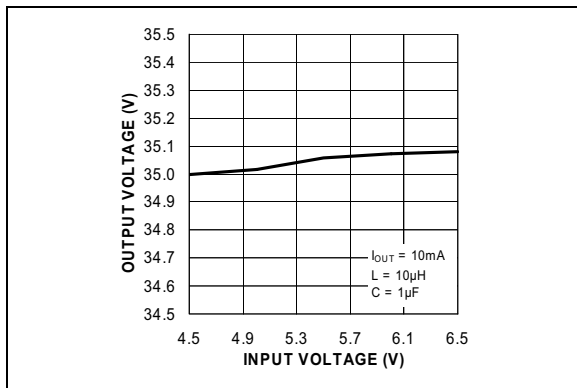

FIGURE 2-8: Line Regulation ($V_{OUT} = 35V$).

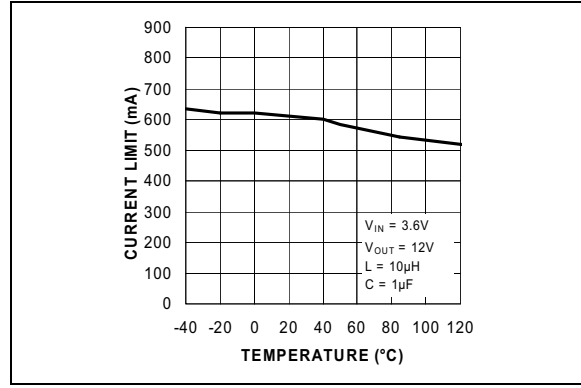

FIGURE 2-11: Switch Current Limit vs. Temperature.

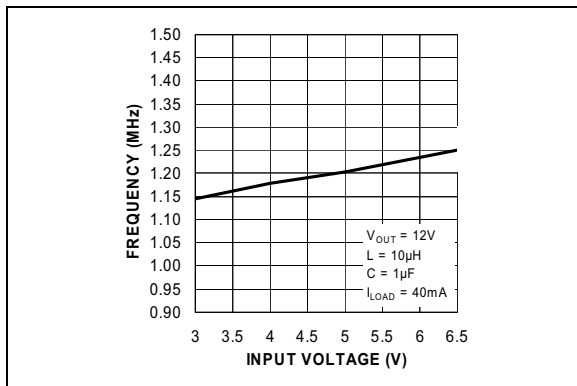

FIGURE 2-9: Frequency vs. Input Voltage.

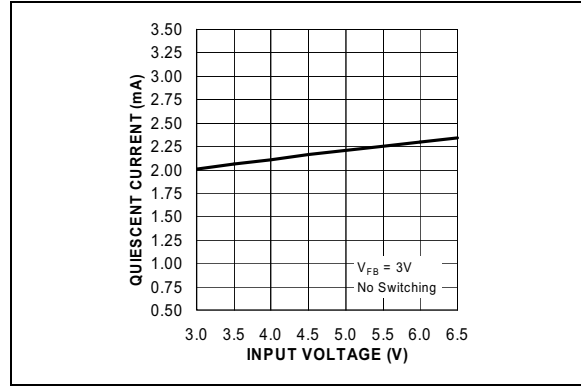

FIGURE 2-12: Quiescent Current vs. Input Voltage.

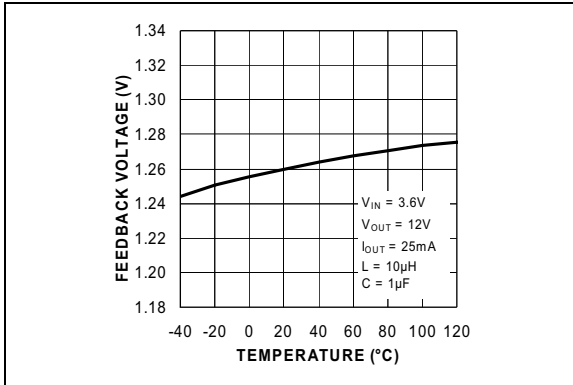

FIGURE 2-13: Feedback Voltage vs. Temperature.

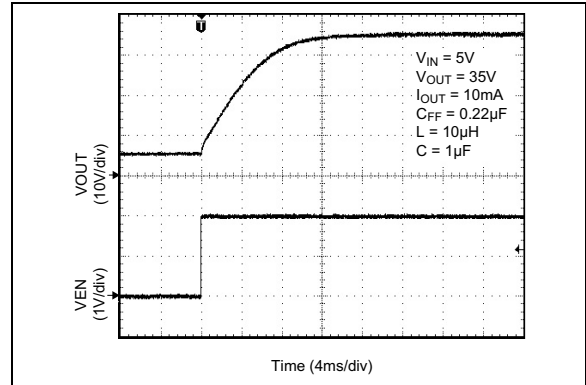

FIGURE 2-16: Enable Turn-On with Soft-Start.

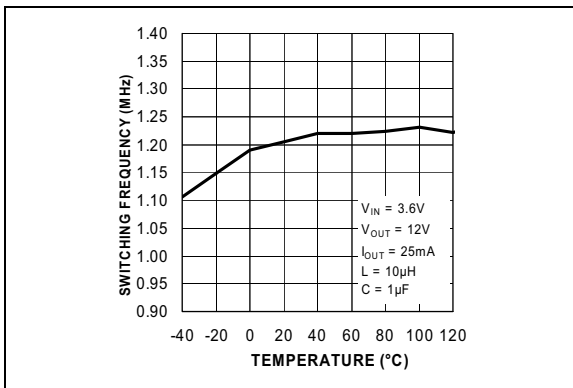

FIGURE 2-14: Switching Frequency vs. Temperature.

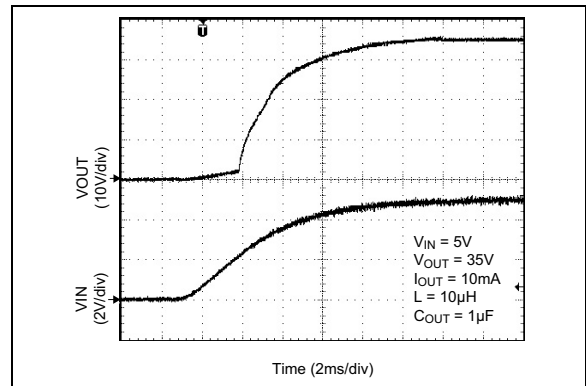

FIGURE 2-17: Input Turn-On.

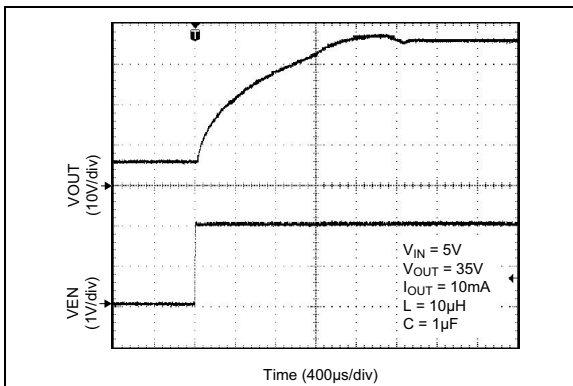

FIGURE 2-15: Enable Turn-On.

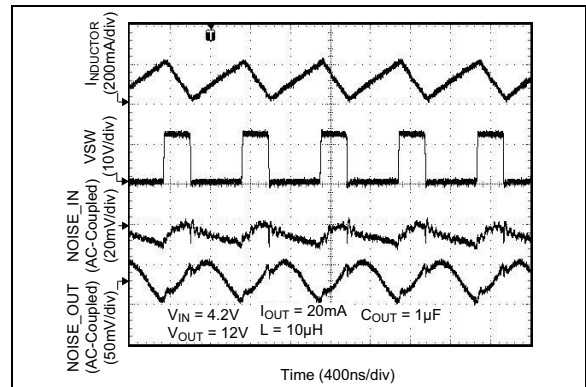

FIGURE 2-18: Switching Waveform – Continuous.

MIC2619

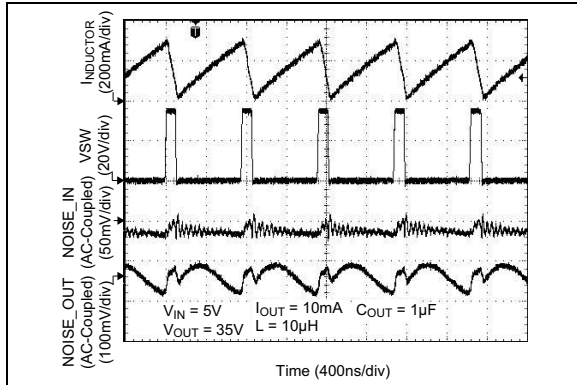

FIGURE 2-19: Switching Waveform – Continuous.

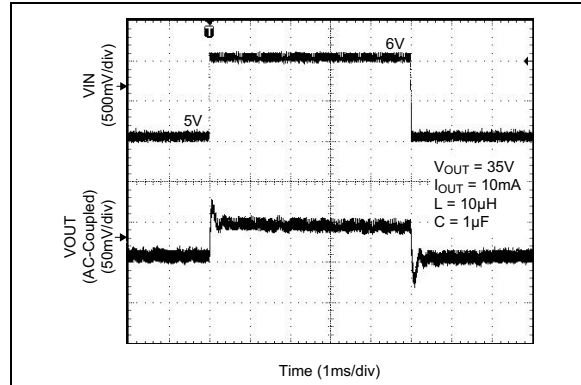

FIGURE 2-22: Line Transient, $V_{OUT} = 35V$.

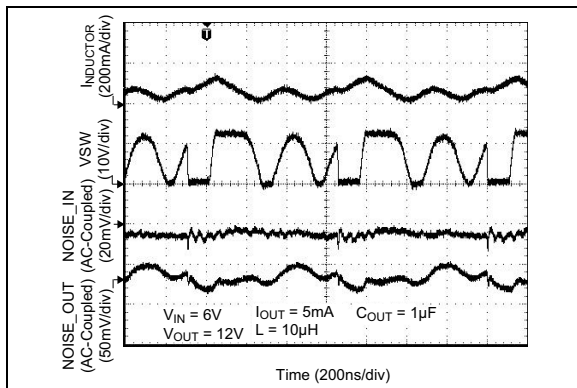

FIGURE 2-20: Switching Waveform – Discontinuous.

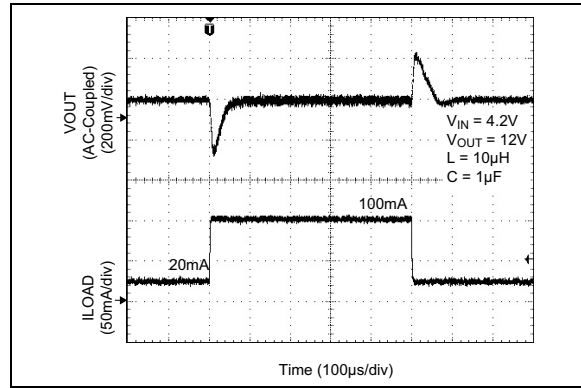

FIGURE 2-23: Load Transient, $V_{OUT} = 12V$.

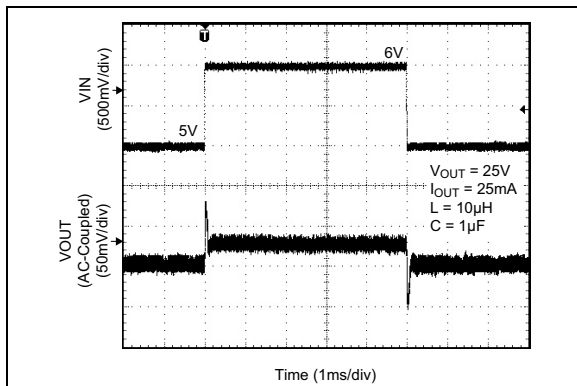

FIGURE 2-21: Line Transient, $V_{OUT} = 25V$.

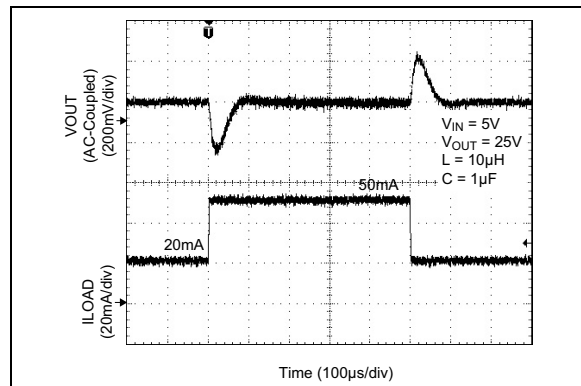

FIGURE 2-24: Load Transient, $V_{OUT} = 25V$.

3.0 PIN DESCRIPTIONS

The descriptions of the pins are listed in [Table 3-1](#).

TABLE 3-1: PIN FUNCTION TABLE

Pin Number	Pin Name	Description
1	SW	Switch Node (Input): Internal power bipolar collector.
2	GND	Ground.
3	FB	Feedback (Input): Output voltage sense node. Connect external resistor network to set output voltage. Nominal feedback voltage is 1.265V.
4	EN	Enable (Input): Logic high enables regulator. Logic low shuts down regulator. Do not leave floating.
5	OVP	Overvoltage Protection (Input): Programmable to 35V; adjustable through resistor divider network.
6	VIN	Supply (Input): 2.8V to 6.5V for internal circuitry. Requires a minimum 1.0 μ F ceramic capacitor.

MIC2619

4.0 FUNCTIONAL DESCRIPTION

The MIC2619 is a constant frequency, PWM current mode boost regulator. It is composed of an oscillator, slope compensation ramp generator, current amplifier, g_m error amplifier, PWM generator, and bipolar output transistor. The oscillator generates a 1.2 MHz clock that triggers the PWM generator to turn on the output transistor and resets the slope compensation ramp generator. The current amplifier is used to measure switch current by amplifying the voltage signal from the internal sense resistor. The output of the current amplifier is summed with the output of the slope compensation ramp generator. This summed current-loop signal is then fed to one of the inputs of the PWM generator.

The g_m error amplifier measures the feedback voltage through the external feedback resistors and amplifies the error between the detected signal and the 1.265V reference voltage. The output of the g_m error amplifier provides the voltage-loop signal that is fed to the other input of the PWM generator. When the current-loop signal exceeds the voltage loop signal, the PWM generator turns off the bipolar output transistor. The next clock period initiates the next switching cycle, maintaining the constant frequency current-mode PWM control.

4.1 VIN

VIN provides power to the control and reference circuitry as well as the switch mode regulator MOSFETs. Due to the high speed switching, a 1 μ F capacitor is recommended as close as possible to the VIN and GND pin.

4.2 EN

The enable pin provides a logic level control of the output. In the off state, supply current of the device is greatly reduced (typically $<0.1 \mu$ A). Also, in the off state, the output drive is placed in a “tri-stated” condition, where the bipolar output transistor is in an “off” state or non-conducting state.

4.3 OVP

The OVP pin provides overvoltage protection on the output of the MIC2619. When the OVP circuit is tripped, the output voltage remains at the set OVP voltage. Because the OVP circuit operates at a lower frequency than the feedback circuit, output ripple will be higher while in an OVP state. OVP requires a resistor divider network to the output and GND to set the OVP voltage. If the output voltage overshoots the set OVP voltage, then the MIC2619 OVP circuit will shut off the switch; saving itself and other sensitive circuitry downstream. The accuracy of the OVP pin is $\pm 5\%$ and therefore

should be set above the output voltage to ensure noise or other variations will not cause a false triggering of the OVP circuit.

4.4 FB

The feedback pin provides the control path to control the output. FB requires a resistor divider network to the output and GND to set the output voltage.

4.5 SW

The switching pin connects directly to one end of the inductor to VIN and the anode of the Schottky diode to the output. Due to the high switching speed and high voltage associated with this pin, the switch node should be routed away from sensitive nodes.

4.6 GND

The ground pin is the ground path for high current PWM mode. The current loop for the power ground should be kept as small as possible.

5.0 APPLICATIONS INFORMATION

5.1 DC-to-DC PWM Boost Conversion

The MIC2619 is a constant-frequency boost converter. It can convert a low DC input voltage to a higher DC output voltage. Figure 5-1 shows a typical circuit. Boost regulation is achieved by turning on an internal switch, which draws current through the inductor. When the switch turns off, the inductor's magnetic field collapses. This causes the current to be discharged into the output capacitor through an external Schottky diode (D1). The Electrical Characteristics show Input Voltage ripple, Output Voltage ripple, SW Voltage, and Inductor Current for 10 mA load current. Regulation is achieved by modulating the pulse width i.e., pulse-width modulation (PWM).

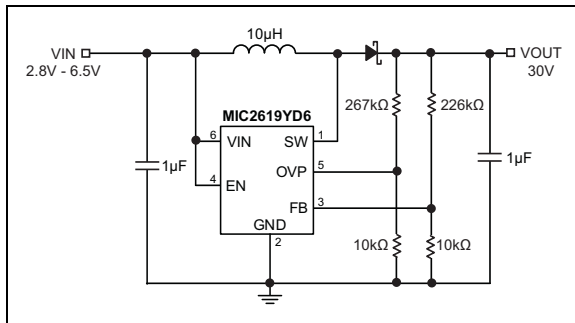

FIGURE 5-1: Typical Application Circuit.

5.2 Duty Cycle Considerations

Duty cycle refers to the switch on-to-off time ratio and can be calculated as follows for a boost regulator:

EQUATION 5-1:

$$D = 1 - \frac{V_{IN}}{V_{OUT}}$$

However, at light loads, the inductor will completely discharge before the end of a switching cycle. The current in the inductor reaches 0A before the end of the switching cycle. This is known as discontinuous conduction mode (DCM). DCM occurs when:

EQUATION 5-2:

$$I_{OUT} < \frac{V_{IN}}{V_{OUT}} \times \frac{I_{PEAK}}{2}$$

Where:

$$I_{PEAK} = \frac{(V_{OUT} - V_{IN})}{L \times f} \times \left(\frac{V_{IN}}{V_{OUT}} \right)$$

In DCM, the duty cycle is smaller than in continuous conduction mode. In DCM, the duty cycle is given by:

EQUATION 5-3:

$$D = \frac{f \times \sqrt{2 \times L \times I_{OUT} \times (V_{OUT} - V_{IN})}}{V_{IN}}$$

The duty cycle required for voltage conversion should be less than the maximum duty cycle of 85%. Also, in light load conditions where the input voltage is close to the output voltage, the minimum duty cycle can cause pulse skipping. This is due to the energy stored in the inductor causing the output to slightly overshoot the regulated output voltage. During the next cycle, the error amplifier detects the output as being high and skips the following pulse. This effect can be reduced by increasing the minimum load or by increasing the inductor value. Increasing the inductor value also reduces the peak current.

5.3 Input Capacitors

A 1 µF ceramic capacitor is recommended on the VIN pin for bypassing. Increasing input capacitance will improve performance and provide greater noise immunity. The input capacitor should be as close as possible to the inductor and the MIC2619, with short traces for good noise performance.

X5R or X7R dielectrics are recommended for the input capacitor. Y5V dielectrics lose most of their capacitance over temperature and are therefore not recommended. Also, tantalum and electrolytic capacitors alone are not recommended because of their reduced RMS current handling, reliability, and ESR increases.

5.4 Output Capacitors

Output capacitor selection is also a trade-off between performance, size, and cost. The minimum recommended output capacitor is 1 µF. Increasing output capacitance will lead to an improved transient response but also an increase in size and cost. X5R or X7R dielectrics are recommended for the output capacitor. Y5V dielectrics lose most of their capacitance over temperature and are therefore not recommended.

MIC2619

5.5 Inductor

Inductor selection will be determined by the following (not necessarily in order of importance)

- Inductance
- Rated current value
- Size requirements
- DC resistance (DCR)

The MIC2619 was designed for use with a 10 μH inductor. Proper selection should ensure the inductor can handle the maximum average and peak currents required by the load. Maximum current ratings of the inductor are generally given in two methods; permissible DC current and saturation current. Permissible DC current can be rated either for a 40°C temperature rise or a 10% to 20% loss in inductance. Ensure the inductor selected can handle the maximum operating current. When saturation current is specified, make sure that there is enough margin so that the peak current will not saturate the inductor. Peak current can be calculated as follows:

EQUATION 5-4:

$$I_{PEAK} = \left[I_{OUT} + V_{OUT} \times \left(\frac{1 - V_{OUT} \times V_{IN}}{2 \times f \times L} \right) \right]$$

As shown by Equation 5-4, the peak inductor current is inversely proportional to the switching frequency and the inductance; the lower the switching frequency or the inductance the higher the peak current. As input voltage increases, the peak current also increases.

The size of the inductor depends on the requirements of the application.

DC resistance (DCR) is also important. While DCR is inversely proportional to size, DCR can represent a significant efficiency loss.

To maintain stability, increasing inductor size will have to be met with an increase in output capacitance. This is due to the unavoidable “right half plane zero” (RHPZ) effect for the continuous current boost converter topology. The frequency at which the right half plane zero occurs can be calculated as follows:

EQUATION 5-5:

$$f = \frac{V_{IN}^2}{V_{OUT} \times L \times I_{OUT} \times 2\pi}$$

The right half plane zero has the undesirable effect of increasing gain, while decreasing phase. This requires that the loop gain is rolled off before this has significant effect on the total loop response. This can be accomplished by either reducing inductance (increasing RHPZ frequency) or increasing the output capacitor value (decreasing loop gain).

5.6 Diode Selection

The MIC2619 requires an external diode for operation. A Schottky diode is recommended for most applications due to their lower forward voltage drop and reverse recovery time. Ensure the diode selected can deliver the peak inductor current and the maximum reverse voltage is rated greater than the output voltage.

5.7 Soft-Start

Feed-forward capacitors can be used to provide soft-start for the MIC2619. Figure 5-2 shows a typical circuit for soft-start applications. Typically, a 0.22 nF feed-forward capacitor will yield 5 ms in rise time.

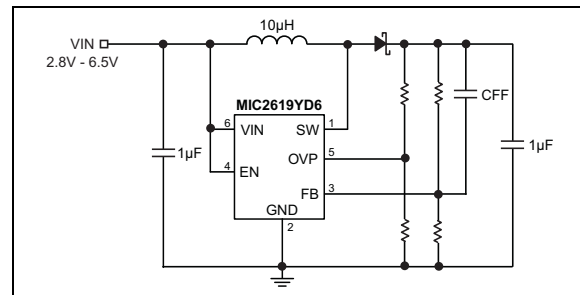

FIGURE 5-2: Soft-Start Circuit.

5.8 Feedback Resistors

The MIC2619 utilizes a feedback pin to compare the output to an internal reference. The output voltage is adjusted by selecting the appropriate feedback resistor network values. Using the evaluation board schematic as a reference, the desired output voltage can be calculated as follows:

EQUATION 5-6:

$$V_{OUT} = V_{REF} \times \left(\frac{R4}{R5} + 1 \right)$$

Where:
 $V_{REF} = 1.265\text{V}$

Overvoltage protection uses the same equation as the feedback pin.

EQUATION 5-7:

$$V_{OVP} = V_{REF} \times \left(\frac{R1}{R2} + 1 \right)$$

6.0 PACKAGING INFORMATION

6.1 Package Marking Information

6-Lead Thin SOT-23*
(Front)

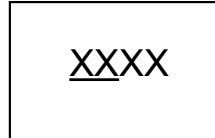

Example

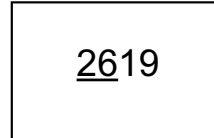

6-Lead Thin SOT-23*
(Back)

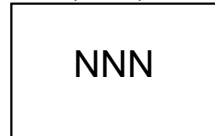

Example



Legend:	<p>XX...X Product code or customer-specific information</p> <p>Y Year code (last digit of calendar year)</p> <p>YY Year code (last 2 digits of calendar year)</p> <p>WW Week code (week of January 1 is week '01')</p> <p>NNN Alphanumeric traceability code</p> <p>(e3) Pb-free JEDEC[®] designator for Matte Tin (Sn)</p> <p>* This package is Pb-free. The Pb-free JEDEC designator (e3) can be found on the outer packaging for this package.</p> <p>•, ▲, ▼ Pin one index is identified by a dot, delta up, or delta down (triangle mark).</p>
Note:	<p>In the event the full Microchip part number cannot be marked on one line, it will be carried over to the next line, thus limiting the number of available characters for customer-specific information. Package may or may not include the corporate logo.</p> <p>Underbar (_) and/or Overbar (¯) symbol may not be to scale.</p>

Note: If the full seven-character YYWWNNN code cannot fit on the package, the following truncated codes are used based on the available marking space:
 6 Characters = YWWNNN; 5 Characters = WWNNN; 4 Characters = WNNN; 3 Characters = NNN;
 2 Characters = NN; 1 Character = N

MIC2619

6-Lead Thin SOT-23 Package Outline and Recommended Land Pattern

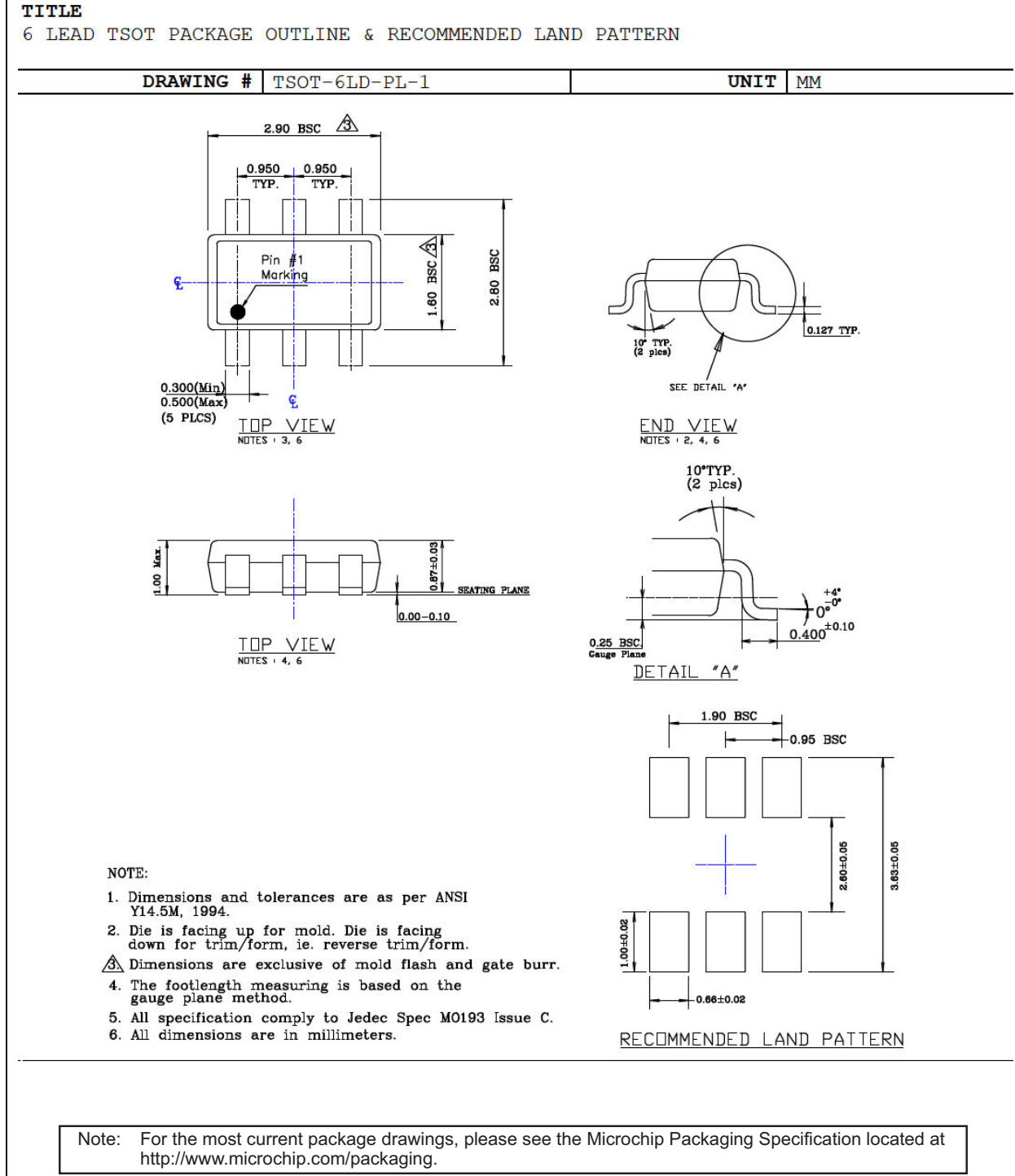

APPENDIX A: REVISION HISTORY

Revision A (May 2022)

- Converted Micrel document MIC2619 to Microchip data sheet DS20006545A.
- Minor text changes throughout.
- Removed the Evaluation Board Schematic and Recommended Layout sections as those appear in the MIC2619 User's Guide.

MIC2619

NOTES:

PRODUCT IDENTIFICATION SYSTEM

To order or obtain information, e.g., on pricing or delivery, contact your local Microchip representative or sales office.

<u>PART No.</u>	<u>X</u>	<u>X</u>	<u>-XX</u>	Examples:
Device	Junction Temperature Range	Package	Media Type	a) MIC2619YD6-TR: 1.2 MHz PWM Boost Converter with OVP, -40°C to +125°C Temperature Range, 6-Lead TSOT-23, 3,000/Reel
Device:	MIC2619:	1.2 MHz PWM Boost Converter with OVP		Note 1: Tape and Reel identifier only appears in the catalog part number description. This identifier is used for ordering purposes and is not printed on the device package. Check with your Microchip Sales Office for package availability with the Tape and Reel option.
Junction Temperature Range:	Y =	-40°C to +125°C		
Package:	D6 =	6-Lead Thin SOT-23		
Media Type:	TR =	3,000/Reel		

MIC2619

NOTES:

Note the following details of the code protection feature on Microchip products:

- Microchip products meet the specifications contained in their particular Microchip Data Sheet.
- Microchip believes that its family of products is secure when used in the intended manner, within operating specifications, and under normal conditions.
- Microchip values and aggressively protects its intellectual property rights. Attempts to breach the code protection features of Microchip product is strictly prohibited and may violate the Digital Millennium Copyright Act.
- Neither Microchip nor any other semiconductor manufacturer can guarantee the security of its code. Code protection does not mean that we are guaranteeing the product is “unbreakable”. Code protection is constantly evolving. Microchip is committed to continuously improving the code protection features of our products.

This publication and the information herein may be used only with Microchip products, including to design, test, and integrate Microchip products with your application. Use of this information in any other manner violates these terms. Information regarding device applications is provided only for your convenience and may be superseded by updates. It is your responsibility to ensure that your application meets with your specifications. Contact your local Microchip sales office for additional support or, obtain additional support at <https://www.microchip.com/en-us/support/design-help/client-support-services>.

THIS INFORMATION IS PROVIDED BY MICROCHIP "AS IS". MICROCHIP MAKES NO REPRESENTATIONS OR WARRANTIES OF ANY KIND WHETHER EXPRESS OR IMPLIED, WRITTEN OR ORAL, STATUTORY OR OTHERWISE, RELATED TO THE INFORMATION INCLUDING BUT NOT LIMITED TO ANY IMPLIED WARRANTIES OF NON-INFRINGEMENT, MERCHANTABILITY, AND FITNESS FOR A PARTICULAR PURPOSE, OR WARRANTIES RELATED TO ITS CONDITION, QUALITY, OR PERFORMANCE.

IN NO EVENT WILL MICROCHIP BE LIABLE FOR ANY INDIRECT, SPECIAL, PUNITIVE, INCIDENTAL, OR CONSEQUENTIAL LOSS, DAMAGE, COST, OR EXPENSE OF ANY KIND WHATSOEVER RELATED TO THE INFORMATION OR ITS USE, HOWEVER CAUSED, EVEN IF MICROCHIP HAS BEEN ADVISED OF THE POSSIBILITY OR THE DAMAGES ARE FORESEEABLE. TO THE FULLEST EXTENT ALLOWED BY LAW, MICROCHIP'S TOTAL LIABILITY ON ALL CLAIMS IN ANY WAY RELATED TO THE INFORMATION OR ITS USE WILL NOT EXCEED THE AMOUNT OF FEES, IF ANY, THAT YOU HAVE PAID DIRECTLY TO MICROCHIP FOR THE INFORMATION.

Use of Microchip devices in life support and/or safety applications is entirely at the buyer's risk, and the buyer agrees to defend, indemnify and hold harmless Microchip from any and all damages, claims, suits, or expenses resulting from such use. No licenses are conveyed, implicitly or otherwise, under any Microchip intellectual property rights unless otherwise stated.

For information regarding Microchip's Quality Management Systems, please visit www.microchip.com/quality.

Trademarks

The Microchip name and logo, the Microchip logo, Adaptec, AnyRate, AVR, AVR logo, AVR Freaks, BesTime, BitCloud, CryptoMemory, CryptoRF, dsPIC, flexPWR, HELDO, IGLOO, JukeBlox, KeeLoq, Kleer, LANCheck, LinkMD, maXStylus, maXTouch, MediaLB, megaAVR, Microsemi, Microsemi logo, MOST, MOST logo, MPLAB, OptoLyzer, PIC, picoPower, PICSTART, PIC32 logo, PolarFire, Prochip Designer, QTouch, SAM-BA, SenGenuity, SpyNIC, SST, SST Logo, SuperFlash, Symmetricom, SyncServer, Tachyon, TimeSource, tinyAVR, UNI/O, Vectron, and XMEGA are registered trademarks of Microchip Technology Incorporated in the U.S.A. and other countries.

AgileSwitch, APT, ClockWorks, The Embedded Control Solutions Company, EtherSynch, Flashtec, Hyper Speed Control, HyperLight Load, IntelliMOS, Libero, motorBench, mTouch, Powermite 3, Precision Edge, ProASIC, ProASIC Plus, ProASIC Plus logo, QuietWire, SmartFusion, SyncWorld, Temux, TimeCesium, TimeHub, TimePictra, TimeProvider, TrueTime, WinPath, and ZL are registered trademarks of Microchip Technology Incorporated in the U.S.A.

Adjacent Key Suppression, AKS, Analog-for-the-Digital Age, Any Capacitor, AnyIn, AnyOut, Augmented Switching, BlueSky, BodyCom, CodeGuard, CryptoAuthentication, CryptoAutomotive, CryptoCompanion, CryptoController, dsPICDEM, dsPICDEM.net, Dynamic Average Matching, DAM, ECAN, Espresso T1S, EtherGREEN, GridTime, IdealBridge, In-Circuit Serial Programming, ICSP, INICnet, Intelligent Paralleling, Inter-Chip Connectivity, JitterBlocker, Knob-on-Display, maxCrypto, maxView, memBrain, Mindi, MiWi, MPASM, MPF, MPLAB Certified logo, MPLIB, MPLINK, MultiTRAK, NetDetach, NVM Express, NVMe, Omniscient Code Generation, PICDEM, PICDEM.net, PICKit, PICtail, PowerSmart, PureSilicon, QMatrix, REAL ICE, Ripple Blocker, RTAX, RTG4, SAM-ICE, Serial Quad I/O, simpleMAP, SimpliPHY, SmartBuffer, SmartHLS, SMART-I.S., storClad, SQI, SuperSwitcher, SuperSwitcher II, Switchtec, SynchroPHY, Total Endurance, TSHARC, USBCheck, VariSense, VectorBlox, VeriPHY, ViewSpan, WiperLock, XpressConnect, and ZENA are trademarks of Microchip Technology Incorporated in the U.S.A. and other countries.

SQTP is a service mark of Microchip Technology Incorporated in the U.S.A.

The Adaptec logo, Frequency on Demand, Silicon Storage Technology, Symmcom, and Trusted Time are registered trademarks of Microchip Technology Inc. in other countries.

GestIC is a registered trademark of Microchip Technology Germany II GmbH & Co. KG, a subsidiary of Microchip Technology Inc., in other countries.

All other trademarks mentioned herein are property of their respective companies.

© 2022, Microchip Technology Incorporated and its subsidiaries.

All Rights Reserved.

ISBN: 978-1-6683-0467-9



MICROCHIP

Worldwide Sales and Service

AMERICAS

Corporate Office
2355 West Chandler Blvd.
Chandler, AZ 85224-6199
Tel: 480-792-7200
Fax: 480-792-7277
Technical Support:
[http://www.microchip.com/
support](http://www.microchip.com/support)
Web Address:
www.microchip.com

Atlanta
Duluth, GA
Tel: 678-957-9614
Fax: 678-957-1455

Austin, TX
Tel: 512-257-3370

Boston
Westborough, MA
Tel: 774-760-0087
Fax: 774-760-0088

Chicago
Itasca, IL
Tel: 630-285-0071
Fax: 630-285-0075

Dallas
Addison, TX
Tel: 972-818-7423
Fax: 972-818-2924

Detroit
Novi, MI
Tel: 248-848-4000

Houston, TX
Tel: 281-894-5983

Indianapolis
Noblesville, IN
Tel: 317-773-8323
Fax: 317-773-5453
Tel: 317-536-2380

Los Angeles
Mission Viejo, CA
Tel: 949-462-9523
Fax: 949-462-9608
Tel: 951-273-7800

Raleigh, NC
Tel: 919-844-7510

New York, NY
Tel: 631-435-6000

San Jose, CA
Tel: 408-735-9110
Tel: 408-436-4270

Canada - Toronto
Tel: 905-695-1980
Fax: 905-695-2078

ASIA/PACIFIC

Australia - Sydney
Tel: 61-2-9868-6733

China - Beijing
Tel: 86-10-8569-7000

China - Chengdu
Tel: 86-28-8665-5511

China - Chongqing
Tel: 86-23-8980-9588

China - Dongguan
Tel: 86-769-8702-9880

China - Guangzhou
Tel: 86-20-8755-8029

China - Hangzhou
Tel: 86-571-8792-8115

China - Hong Kong SAR
Tel: 852-2943-5100

China - Nanjing
Tel: 86-25-8473-2460

China - Qingdao
Tel: 86-532-8502-7355

China - Shanghai
Tel: 86-21-3326-8000

China - Shenyang
Tel: 86-24-2334-2829

China - Shenzhen
Tel: 86-755-8864-2200

China - Suzhou
Tel: 86-186-6233-1526

China - Wuhan
Tel: 86-27-5980-5300

China - Xian
Tel: 86-29-8833-7252

China - Xiamen
Tel: 86-592-2388138

China - Zhuhai
Tel: 86-756-3210040

ASIA/PACIFIC

India - Bangalore
Tel: 91-80-3090-4444

India - New Delhi
Tel: 91-11-4160-8631

India - Pune
Tel: 91-20-4121-0141

Japan - Osaka
Tel: 81-6-6152-7160

Japan - Tokyo
Tel: 81-3-6880-3770

Korea - Daegu
Tel: 82-53-744-4301

Korea - Seoul
Tel: 82-2-554-7200

Malaysia - Kuala Lumpur
Tel: 60-3-7651-7906

Malaysia - Penang
Tel: 60-4-227-8870

Philippines - Manila
Tel: 63-2-634-9065

Singapore
Tel: 65-6334-8870

Taiwan - Hsin Chu
Tel: 886-3-577-8366

Taiwan - Kaohsiung
Tel: 886-7-213-7830

Taiwan - Taipei
Tel: 886-2-2508-8600

Thailand - Bangkok
Tel: 66-2-694-1351

Vietnam - Ho Chi Minh
Tel: 84-28-5448-2100

EUROPE

Austria - Wels
Tel: 43-7242-2244-39
Fax: 43-7242-2244-393

Denmark - Copenhagen
Tel: 45-4485-5910
Fax: 45-4485-2829

Finland - Espoo
Tel: 358-9-4520-820

France - Paris
Tel: 33-1-69-53-63-20
Fax: 33-1-69-30-90-79

Germany - Garching
Tel: 49-8931-9700

Germany - Haan
Tel: 49-2129-3766400

Germany - Heilbronn
Tel: 49-7131-72400

Germany - Karlsruhe
Tel: 49-721-625370

Germany - Munich
Tel: 49-89-627-144-0
Fax: 49-89-627-144-44

Germany - Rosenheim
Tel: 49-8031-354-560

Israel - Ra'anana
Tel: 972-9-744-7705

Italy - Milan
Tel: 39-0331-742611
Fax: 39-0331-466781

Italy - Padova
Tel: 39-049-7625286

Netherlands - Drunen
Tel: 31-416-690399
Fax: 31-416-690340

Norway - Trondheim
Tel: 47-7288-4388

Poland - Warsaw
Tel: 48-22-3325737

Romania - Bucharest
Tel: 40-21-407-87-50

Spain - Madrid
Tel: 34-91-708-08-90
Fax: 34-91-708-08-91

Sweden - Gothenberg
Tel: 46-31-704-60-40

Sweden - Stockholm
Tel: 46-8-5090-4654

UK - Wokingham
Tel: 44-118-921-5800
Fax: 44-118-921-5820