PXle-8301

Features

2022-07-06



Contents

Introduction.....	3
Description and Features.....	3
Functional Overview.....	3
Functional Block Diagram.....	3
Basic MXI-Express Thunderbolt Systems.....	4
Thunderbolt Bus Extension.....	4
Host and Operating System Compatibility.....	5
Backwards Compatibility.....	5
Installation and Configuration.....	5
Equipment Needed.....	5
Unpacking.....	6
Hardware Installation.....	6
Installing a PXIe-8301.....	6
Cabling.....	8
Powering On the MXI-Express Thunderbolt System.....	9
Powering Off the MXI-Express Thunderbolt System.....	9
LED Indicator.....	9
Software Installation and Configuration.....	9
Common Questions.....	10
General Hardware.....	10
General Software.....	11
PXIe-8301 Specifications.....	11
Physical.....	12
Power Requirements.....	12
Safety.....	12
Documentation Notice for Third Party Software.....	13

Introduction

This document provides installation, configuration, and reference information for the PXIe-8301 remote control module.

Description and Features



Note In this manual, whenever a PXI Express chassis is referenced, you could use a CompactPCI Express chassis instead.

MXI-Express Thunderbolt extends PCI Express communication over Thunderbolt cable. With MXI-Express Thunderbolt, you can do the following:

- Control a PXI Express backplane with a Thunderbolt-enabled PC or laptop.
- Physically separate the measurement or automation system from a host PC.

Functional Overview

The PXIe-8301 remote control module is based on Intel Thunderbolt 3 technology. This enables control of a PXI Express chassis from a host PC with an available Thunderbolt 3 port. Thunderbolt technology is transparent to device drivers, so no additional software is needed for CompactPCI Express-level support for PXI Express devices in connected chassis.



Note For full PXI/PXI Express functionality such as chassis and controller identification, trigger routing, and slot detection, install the latest version of PXI Platform Services. This software is included with your kit; you also can find it at ni.com/updates by searching for **PXI Platform Services**.

The link between the PC and the chassis is a Thunderbolt 3 link. This link is a dual-simplex communication channel comprised of differentially driven signal pairs. The link can transmit at a rate of up to 40 Gbps in each direction simultaneously.

Functional Block Diagram

Figure 1. PXIe-8301 Block Diagram

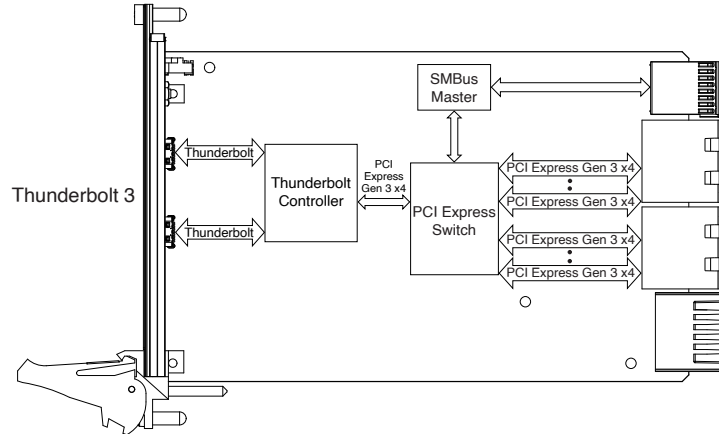

The PXIe-8301 supports 2 and 4-link configuration per the chassis' capabilities.

The PXIe-8301 is compatible with previous generations of PXI Express but requires a Gen 3 PXI Express chassis for maximum performance. National Instruments offers Gen 3 chassis that allow the PXIe-8301 to establish Gen 3 backplane links.

Basic MXI-Express Thunderbolt Systems

The simplest MXI-Express Thunderbolt system consists of a PC connected to a PXIe-8301 in the controller slot of a PXI Express chassis, as shown in the following figure.

Figure 2. Example of a Basic MXI-Express Thunderbolt Link Topology

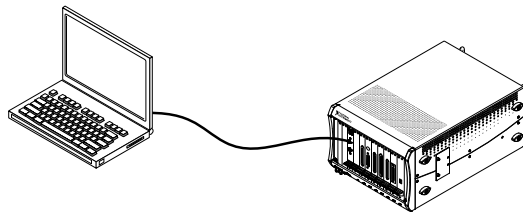

Thunderbolt Bus Extension

You can daisy-chain from a PXI Express chassis controlled by a laptop to an additional Thunderbolt 3 compatible device using MXI-Express Thunderbolt products. The following figure shows how you can use MXI-Express Thunderbolt

cards to connect multiple Thunderbolt 3 compatible devices to a PC in a daisy-chain topology.

Figure 3. Example of a Daisy-Chain MXI-Express Thunderbolt Link Topology

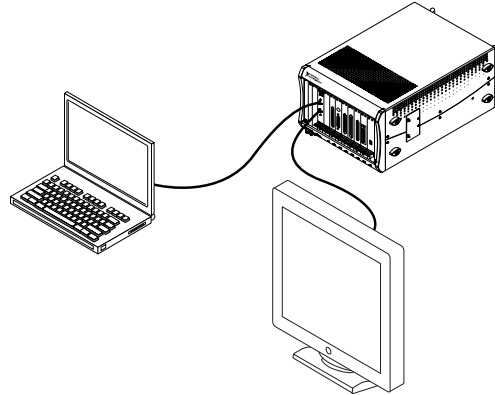

Host and Operating System Compatibility

The PXIe-8301 remote control module is compatible with host PCs that contain a Thunderbolt 3 port and are running a native (nonvirtualized) operating system that supports Thunderbolt connectivity. Note that while an operating system may support a Thunderbolt connection, it may lack support for other National Instruments hardware and software.

Backwards Compatibility

National Instruments recommends connecting the PXIe-8301 remote control module to a Thunderbolt 3 port on the host PC using a Thunderbolt 3 cable. Because Thunderbolt 3 is backwards-compatible with previous Thunderbolt generations, it may be possible to use adapters to establish connections with host PCs or devices with previous-generation Thunderbolt ports. Data throughput performance may vary between Thunderbolt generations.

Installation and Configuration

This section explains how to unpack, install, and configure the MXI-Express Thunderbolt hardware and software.

Equipment Needed

- Host PC with an available Thunderbolt 3 port
- PXI Express chassis
- Thunderbolt 3 cable
- One PXIe-8301

Unpacking

Your MXI-Express Thunderbolt products are shipped in antistatic packages to prevent electrostatic discharge (ESD) to the devices. ESD can damage several components on the device.



Caution Never touch the exposed pins of connectors. Doing so may damage the device.

To avoid such damage in handling the device, take the following precautions:

- Ground yourself using a grounding strap or by holding a grounded object.
- Touch the antistatic package to a metal part of the computer chassis before removing the device from the package.

Remove the device from the package and inspect the device for loose components or any sign of damage. Notify NI if the device appears damaged in any way. Do not install a damaged device into the computer or into a PXI Express chassis.

Store the device in the antistatic envelope when not in use.

Hardware Installation



Caution The protection provided by the MXI-Express Thunderbolt products can be impaired if it is used in a manner not described in this document.

Installing a PXIe-8301

Complete the following steps to install the PXIe-8301 in your PXI Express chassis.

1. Power off your PXI Express chassis, but leave it plugged in while installing the PXIe-8301. The power cord grounds the chassis and protects it from electrical damage while you install the module.



Caution To protect both yourself and the chassis from electrical hazards, leave the chassis off until you finish installing the PXIe-8301.

2. Remove or open any doors or covers blocking access to the system slot of the PXI Express chassis in which you intend to install the PXIe-8301.
3. Touch a metal part of the chassis to discharge any static electricity that might be on your clothes or body.
4. Make sure the injector/ejector handle is in its downward position. Be sure to remove all connector packaging and protective caps from retaining screws on the module. Align the PXIe-8301 with the card guides on the top and bottom of the system controller slot.



Caution Do not raise the injector/ejector handle as you insert the PXIe-8301 board. It will not insert properly unless the handle is in its downward position so that it does not interfere with the injector/ejector rail on the chassis, as shown in the following figure.

5. Hold the handle as you slowly slide the module into the chassis system slot until the handle catches on the injector/ejector rail.
6. Raise the injector/ejector handle until the module firmly seats into the backplane receptacle connectors. The front panel of the PXIe-8301 should be even with the front panel of the chassis.
7. Tighten the bracket-retaining screws on the top and bottom of the front panel to secure the NI PXI Express board to the chassis.
8. Replace or close any doors or covers to the chassis.

Figure 4. PXIe-8301 Installation In a PXI Express Chassis

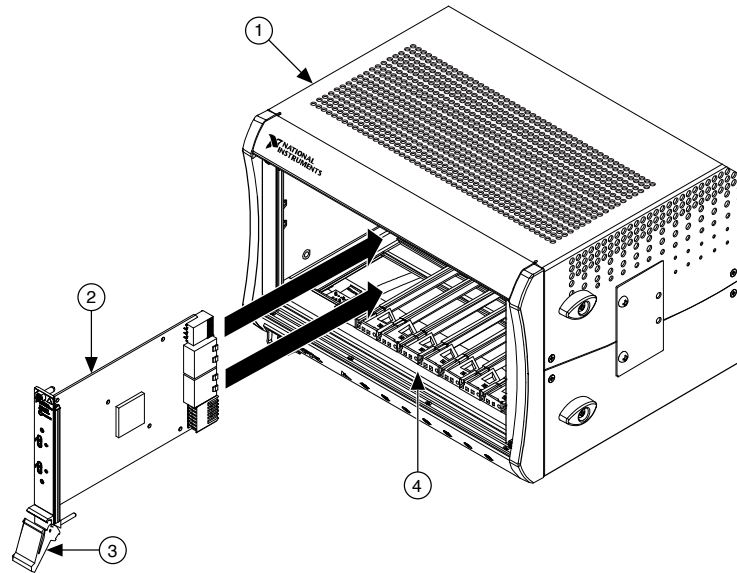

1. PXI Express Chassis
2. PXIe-8301
3. Ejector Handle in Down Position
4. Injector/Ejector Rail

Cabling

The following table shows the various MXI-Express Thunderbolt cables available from National Instruments.

Description	Cable Length (Meters)	Part Number
MXI-Express Thunderbolt active cable	2 m	785607-02
MXI-Express Thunderbolt passive cable	2 m	785608-02

Connect the MXI-Express Thunderbolt cable to the host PC Thunderbolt port and MXI-Express Thunderbolt card. The cables have no polarity, so you can connect either end to either card. The cable plugs are reversible, and there is no defined upstream or downstream port on the PXIe-8301.



Caution Although Thunderbolt is a hotpluggable technology, avoid removing the cable after the system is powered on. Doing so can hang or

cause errors in applications communicating with devices behind MXI-Express Thunderbolt. If a cable becomes unplugged, plug it back into the system.

For more information about MXI-Express Thunderbolt cabling, go to ni.com/thunderbolt.

Powering On the MXI-Express Thunderbolt System

Power up both the PXI Express chassis and the host PC. There are no requirements for how they are powered on. Observe the LED status on the PXIe-8301 where applicable. A properly connected and powered up system should report a valid link and power status once the host PC is powered on. Refer to the **LED Indicators** section for more information.

Powering Off the MXI-Express Thunderbolt System

Power off both the chassis and host PC individually.

LED Indicator

The tri-color PWR/LINK LED on the PXIe-8301 front panel gives status information about the power supply and link state, as the following table describes.

Board	LED	Color	Meaning
PXIe-8301 (140652x-01L)	PWR/LINK	Off	Power is off
		Blinking Red	Power is out of spec
		Solid Amber	Power is within spec; no link to chassis
		Solid Green	Power is within spec; link established

Software Installation and Configuration

MXI-Express Thunderbolt is based on PCI Express technology, using PCI Express switches and/or bridges to enable control of a PXI Express chassis from a host with an available Thunderbolt 3 port. This technology is recognized as a collection of PCI-

to-PCI bridges to the operating system, and should automatically have CompactPCI Express level support without any additional software.



Note For full PXI/PXI Express functionality such as chassis and controller identification, trigger routing, and slot detection, install the PXI Platform Services software included with your kit. You also can find this software at ni.com/updates by searching for **PXI Platform Services**.

For operating system support, refer to the KnowledgeBase 53399AQ7, **PXI Platform Services Operating System Support**, at ni.com/kb.



Note The following requires the PXI Platform Services software and Measurement & Automation Explorer (MAX), included on your **PXI Platform Services** CD or your driver CD.

For information about configuring your system in MAX, open MAX and navigate to Help»Help Topics»PXI.

Common Questions

This section lists common questions related to the use of the MXI-Express Thunderbolt controllers.

General Hardware

Can I daisy-chain multiple chassis using a PXIe-8301 device?

NI officially supports only one chassis configuration. While it may be possible to connect additional chassis, this capability will vary across your specific hardware setup.

Will my PC work with MXI-Express Thunderbolt products?

Your PC will work with MXI-Express Thunderbolt products if it has a Thunderbolt port or a port with a Thunderbolt marking.

Can I use the PXIe-8301 with any USB or USB Type-C port on my PC?

No. The PXIe-8301 requires your host PC to have a Thunderbolt 3 port.

How is Thunderbolt 3 different from USB Type-C?

Although Thunderbolt 3 uses the same physical USB Type-C connector, it is a superset solution which includes USB 3.1, Thunderbolt, and DisplayPort 1.2. For more information, refer to thunderbolttechnology.net/tech/faq.

What is the difference between the two ports on the PXIe-8301?

Both ports are functionally equivalent, and you can choose either port to connect to your PC. You can use the remaining port to daisy-chain Thunderbolt or other devices including storage, display, and dock.

General Software

Under which operating systems will MXI-Express Thunderbolt products work?

MXI-Express Thunderbolt is recognized as a collection of PCI-to-PCI bridges to the majority of operating systems. It should automatically have CompactPCI Express support with most systems such as Windows and Macintosh OS X. For full PXI Express functionality, PXI Platform Services software is required.

What software is required to use my MXI-Express Thunderbolt kit?

For Windows, the required software is included as part of the latest version of NI PXI Platform Services included with your kit. The software for your MXI-Express Thunderbolt controller enhances the product, allowing you to view information about the organization of your PXI Express system, gain access to the trigger routing capabilities of the PXI Express chassis, and programmatically retrieve data about the chassis and modules you have installed.

Refer to KnowledgeBase KB 53399AQ7, **PXI Platform Services Operating System Support**, for the current supported operating systems for NI PXI Platform Services.

If the operating system supports Thunderbolt connectivity, but doesn't support PXI Platform Services, you can still use MXI-Express Thunderbolt as a PCI Express expansion solution. However, access to features such as chassis and controller identification, trigger routing, and slot detection will be lost.

PXIe-8301 Specifications



Note Specifications are subject to change without notice.



Caution Using the PXIe-8301 in a manner not described in this user manual can impair the protection the controller provides.

Physical

Dimensions	10.7 cm × 17.5 cm (4.4 in. × 6.9 in.)
Slot requirements	One system slot (PXI Express)
Compatibility	Fully compatible with the PXI Express Hardware Specification , Revision 2.0, PICMG CompactPCI Express EXP.0 R2.0 Specification , and Intel Thunderbolt 3
Weight	0.16 kg (0.35 lb) typical

Power Requirements

Power Rail	Typical Current	Maximum Current
+3.3 V	480 mA	600 mA
+5 V	420 mA	500 mA
+12 V	850 mA	4.2 A
+5 V _{AUX}	160 mA	200 mA

Safety

This product is designed to meet the requirements of the following standards of safety for information technology equipment:

- IEC 61010-1, EN 61010-1
- UL 61010-1, CSA C22.2 No. 61010-1



Note For UL and other safety certifications, refer to the product label or the [Online Product Certification](#) section.

Electromagnetic Compatibility

This product meets the requirements of the following EMC standards for electrical equipment for measurement, control, and laboratory use:

- EN 61326-1 (IEC 61326-1): Class A emissions; Basic immunity
- EN 55011 (CISPR 11): Group 1, Class A emissions
- AS/NZS CISPR 11: Group 1, Class A emissions
- FCC 47 CFR Part 15B: Class A emissions
- ICES-001: Class A emissions



Note In the United States (per FCC 47 CFR), Class A equipment is intended for use in commercial, light-industrial, and heavy-industrial locations. In Europe, Canada, Australia, and New Zealand (per CISPR 11), Class A equipment is intended for use only in heavy-industrial locations.



Note Group 1 equipment (per CISPR 11) is any industrial, scientific, or medical equipment that does not intentionally generate radio frequency energy for the treatment of material or inspection/analysis purposes.



Note For EMC declarations and certifications, and additional information, refer to the **Online Product Certification** section.

Documentation Notice for Third Party Software

This product includes code from WISHBONE I2C-Master Core rev 0.3 licensed by a third party or parties that is subject to the following notice(s):

Copyright © 2000 Richard Herveille

richard@asics.ws

This source file may be used and distributed without restriction provided that this copyright statement is not removed from the file and that any derivative work contains the original copyright notice and the associated disclaimer.

THIS SOFTWARE IS PROVIDED "AS IS" AND WITHOUT ANY EXPRESS OR IMPLIED WARRANTIES, INCLUDING, BUT NOT LIMITED TO, THE IMPLIED WARRANTIES OF MERCHANTABILITY AND

FITNESS FOR A PARTICULAR PURPOSE. IN NO EVENT SHALL THE AUTHOR OR CONTRIBUTORS BE LIABLE FOR ANY DIRECT, INDIRECT, INCIDENTAL, SPECIAL, EXEMPLARY, OR CONSEQUENTIAL DAMAGES (INCLUDING, BUT NOT LIMITED TO, PROCUREMENT OF SUBSTITUTE GOODS OR SERVICES; LOSS OF USE, DATA, OR PROFITS; OR BUSINESS INTERRUPTION) HOWEVER CAUSED AND ON ANY THEORY OF LIABILITY, WHETHER IN CONTRACT, STRICT LIABILITY, OR TORT (INCLUDING NEGLIGENCE OR OTHERWISE) ARISING IN ANY WAY OUT OF THE USE OF THIS SOFTWARE, EVEN IF ADVISED OF THE POSSIBILITY OF SUCH DAMAGE.