NI-9375 Getting Started

2022-07-06



Contents

Overview.....	3
Safety Guidelines.....	3
NI 9375 with Spring Terminal (Black Connector) Safety Voltages.....	3
Safety Guidelines for Hazardous Locations.....	4
Electromagnetic Compatibility Guidelines.....	5
Special Conditions for Marine Applications.....	6
Preparing the Environment.....	6
NI 9375 Pinout.....	6
Sourcing-Output Connections.....	7
Connecting Digital Devices.....	8
Protecting the Digital Outputs from Flyback Voltages.....	8
Connecting to a Spring-Terminal Connector.....	9
High-Vibration Application Connections.....	10
I/O Protection.....	10
Where to Go Next.....	10
NI Services.....	11

Overview

This document explains how to connect to the NI 9375. In this document, the NI 9375 with spring terminal and the NI 9375 with DSUB are referred to inclusively as the NI 9375.



Note Before you begin, read the **NI 9375 Safety, Environmental, and Regulatory Information** document on ni.com/manuals and complete the software and hardware installation procedures in your chassis documentation.



Note The guidelines in this document are specific to the NI 9375. The other components in the system might not meet the same safety ratings. Refer to the documentation for each component in the system to determine the safety and EMC ratings for the entire system.

Safety Guidelines



Caution Observe all instructions and cautions in the user documentation. Using the product in a manner not specified can damage the product and compromise the built-in safety protection.



Attention Suivez toutes les instructions et respectez toutes les mises en garde de la documentation d'utilisation. L'utilisation du produit de toute autre façon que celle spécifiée risque de l'endommager et de compromettre la protection de sécurité intégrée.

NI 9375 with Spring Terminal (Black Connector) Safety Voltages

Connect only voltages that are within the following limits.

Channel-to-COM or Vsup-to-COM	30 V DC maximum
-------------------------------	-----------------

Isolation

DI bank-to-DO bank	60 V DC maximum
Channel-to-Channel	No isolation between channels

Channel-to-earth ground

Continuous	60 V DC, Measurement Category I
Withstand	1,000 V RMS, verified by a 5 s dielectric withstand test

Safety Guidelines for Hazardous Locations

The NI 9375 is suitable for use in Class I, Division 2, Groups A, B, C, D, T4 hazardous locations; Class I, Zone 2, AEx nA IIC T4 Gc and Ex nA IIC T4 Gc hazardous locations; and nonhazardous locations only. Follow these guidelines if you are installing the NI 9375 in a potentially explosive environment. Not following these guidelines may result in serious injury or death.



Caution Do not disconnect I/O-side wires or connectors unless power has been switched off or the area is known to be nonhazardous.



Caution Do not remove modules unless power has been switched off or the area is known to be nonhazardous.



Caution Substitution of components may impair suitability for Class I, Division 2, or Zone 2.



Caution The system must be installed in an enclosure certified for the intended hazardous (classified) location, having a tool secured cover/door, where a minimum protection of at least IP54 is provided.

Special Conditions for Hazardous Locations Use in Europe and Internationally

The NI 9375 has been evaluated as Ex nA IIC T4 Gc equipment under DEMKO 07ATEX 0626664X and is IECEx UL 14.0089X certified. Each NI 9375 is marked Ⓢ II 3G and is suitable for use in Zone 2 hazardous locations, in ambient temperatures of $-40\text{ °C} \leq T_a \leq 70\text{ °C}$. If you are using the NI 9375 in Gas Group IIC hazardous locations, you must use the device in an NI chassis that has been evaluated as Ex nC IIC T4, Ex IIC T4, Ex nA IIC T4, or Ex nL IIC T4 equipment.



Caution Transient protection shall be provided that is set at a level not exceeding 140% of the peak rated voltage value of 85 V at the supply terminals to the equipment.



Caution The system shall only be used in an area of not more than Pollution Degree 2, as defined in IEC/EN 60664-1.



Caution The system shall be mounted in an ATEX/IECEx-certified enclosure with a minimum ingress protection rating of at least IP54 as defined in IEC/EN 60079-15.



Caution The enclosure must have a door or cover accessible only by the use of a tool.

Electromagnetic Compatibility Guidelines

This product was tested and complies with the regulatory requirements and limits for electromagnetic compatibility (EMC) stated in the product specifications. These requirements and limits provide reasonable protection against harmful interference when the product is operated in the intended operational electromagnetic environment.

This product is intended for use in industrial locations. However, harmful interference may occur in some installations, when the product is connected to a peripheral device or test object, or if the product is used in residential or

commercial areas. To minimize interference with radio and television reception and prevent unacceptable performance degradation, install and use this product in strict accordance with the instructions in the product documentation.

Furthermore, any changes or modifications to the product not expressly approved by National Instruments could void your authority to operate it under your local regulatory rules.

Special Conditions for Marine Applications

Some products are approved for marine (shipboard) applications. To verify marine approval certification for a product, visit ni.com/product-certifications, search by model number, and click the appropriate link.



Notice In order to meet the EMC requirements for marine applications, install the product in a shielded enclosure with shielded and/or filtered power and input/output ports. In addition, take precautions when designing, selecting, and installing measurement probes and cables to ensure that the desired EMC performance is attained.

Preparing the Environment

Ensure that the environment in which you are using the NI 9375 meets the following specifications.

Operating temperature (IEC 60068-2-1, IEC 60068-2-2)	-40 °C to 70 °C
Operating humidity (IEC 60068-2-78)	10% RH to 90% RH, noncondensing
Pollution Degree	2
Maximum altitude	2,000 m

Indoor use only.



Note Refer to the device datasheet on ni.com/manuals for complete specifications.

NI 9375 Pinout

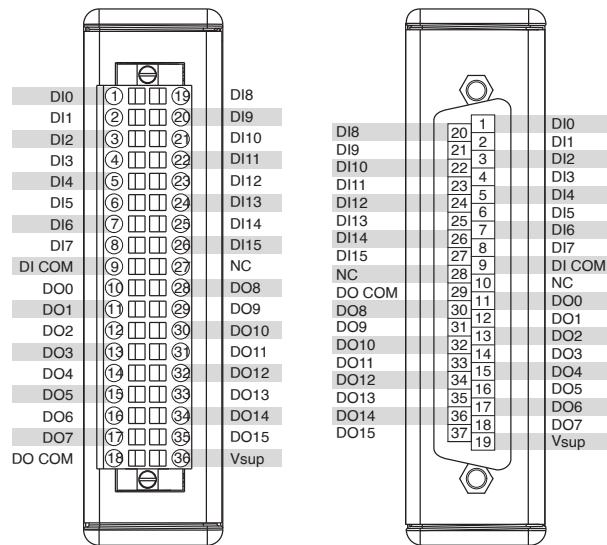

Signal	Description
DI	Digital input signal connection
DI COM	Common reference connection for the digital inputs
DO	Digital output signal connection
DO COM	Common reference connection for the digital outputs
NC	No connection
V _{sup}	Voltage supply connection

Table 1. Signal Descriptions

Sourcing-Output Connections

You can connect 2- and 3-wire sourcing-output devices to the NI 9375.

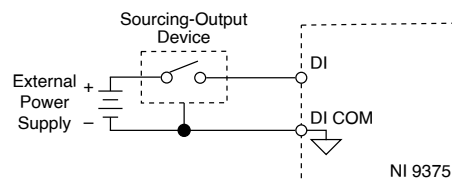

The NI 9375 channel registers as ON when the sourcing-output device drives enough current or applies enough voltage to DI. If no device is connected to DI, the channel registers as OFF.

Connecting Digital Devices

You can connect a variety of industrial devices, such as solenoids, motors, actuators, relays, and lamps to the NI 9375. You must connect an external power supply to the NI 9375. The power supply provides the current for the output channels.

Figure 1. Connecting an Industrial Device to the NI 9375

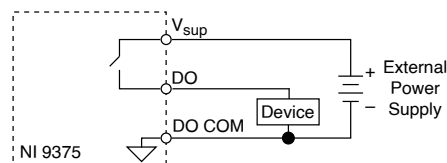

Caution Do not install or remove C Series modules from your system if any external power supplies connected to the V_{sup} and COM pins are powered on.



Attention Ne pas installer ou retirer les modules de la Série C de votre système si une alimentation externe connectée aux broches V_{sup} et COM est sous tension.

Ensure that the devices you connect to the NI 9375 are compatible with the output specifications of the NI 9375. Refer to the device datasheet at ni.com/manuals for output specifications.



Note When the industrial device is off, DO is not connected to COM. For large source impedances, you must use a pull-down resistor between DO and COM. Go to ni.com/r/cseriesdopulsegen for more information.

Protecting the Digital Outputs from Flyback Voltages

If the channel is switching an inductive or energy-storing device such as a solenoid, motor, or relay, and the device does not have flyback protection, install an external flyback diode.

Figure 2. Connecting a Flyback Diode

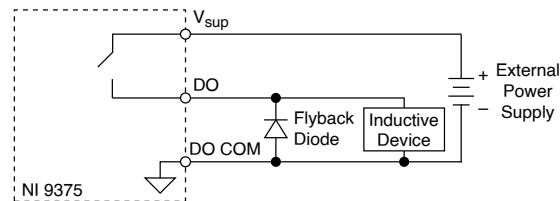

Connecting to a Spring-Terminal Connector

What to Use

- NI 9375 spring-terminal connector
- 0.08 mm² to 1.0 mm² (28 AWG to 18 AWG) copper conductor wire with 7 mm (0.28 in.) of insulation stripped from the end
- Flathead screwdriver with a 2.3 mm x 1.0 mm (0.09 in. x 0.04 in.) blade, included with the NI 9375

What to Do

Complete the following steps to connect wires to the spring-terminal connector.

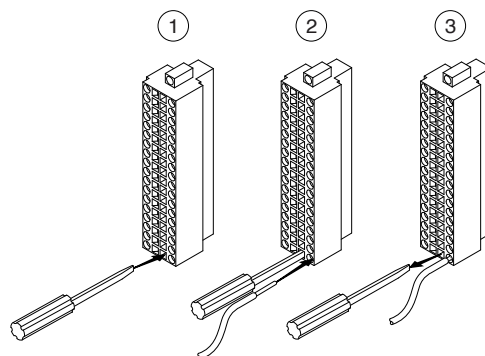

1. Insert the screwdriver into a spring clamp activation slot to open the corresponding connector terminal.
2. Press a wire into the open connector terminal.
3. Remove the screwdriver from the activation slot to clamp the wire into place.

High-Vibration Application Connections

If your application is subject to high vibration, NI recommends that you use the NI 9940 backshell kit to protect connections to the NI 9375 with spring terminal.

I/O Protection

Each DO channel on the NI 9375 has circuitry that protects it from overcurrents resulting from a short-circuit or faulty loads.



Notice Overvoltage and reverse bias voltage conditions can damage the NI 9375. Check the voltage specifications for all devices that you connect to the NI 9375.

When a short circuit is present on a digital output channel, the DO channel cycles off and on until the short circuit is removed or the current returns to an acceptably low level. An overcurrent state can affect the performance of the NI 9375 and other modules in the system. To ensure safe and proper operation, the digital outputs should not exceed the maximum continuous output current specification.

Where to Go Next

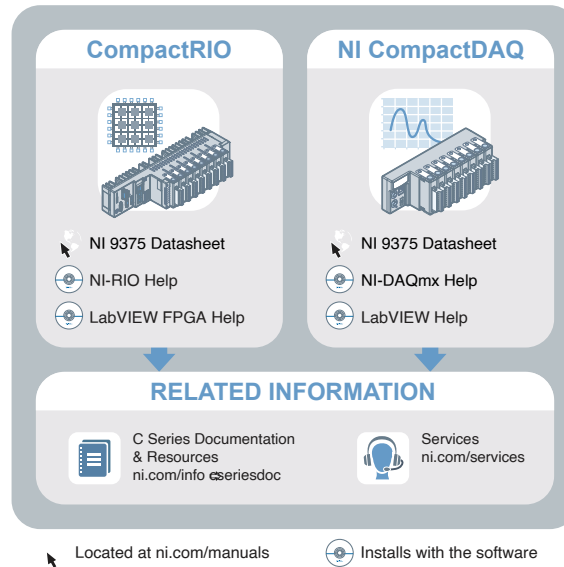

NI Services

Visit ni.com/support to find support resources including documentation, downloads, and troubleshooting and application development self-help such as tutorials and examples.

Visit ni.com/services to learn about NI service offerings such as calibration options, repair, and replacement.

Visit ni.com/register to register your NI product. Product registration facilitates technical support and ensures that you receive important information updates from NI.

NI corporate headquarters is located at 11500 N Mopac Expwy, Austin, TX, 78759-3504, USA.