NI-9154 Getting Started

2022-07-06



Contents

Overview.....	3
Safety Guidelines.....	3
Safety Guidelines for Hazardous Locations.....	3
Electromagnetic Compatibility Guidelines.....	5
Preparing the Environment.....	6
What You Need to Install the NI-9154.....	6
Installing C Series Modules.....	7
Removing C Series Modules.....	8
Connecting the NI 9154 to Ground.....	9
Connecting One or More NI-9154 Chassis to the MXI-Express Host System or a Target.	10
Wiring Power to the Chassis.....	11
Chassis Powerup Options.....	11
Checking MXI-Express LINK LEDs for Status.....	12
Powering Down the MXI-Express System.....	12
Where to Go Next.....	12
NI Services.....	13

Overview

This document describes how to begin using the NI-9154.

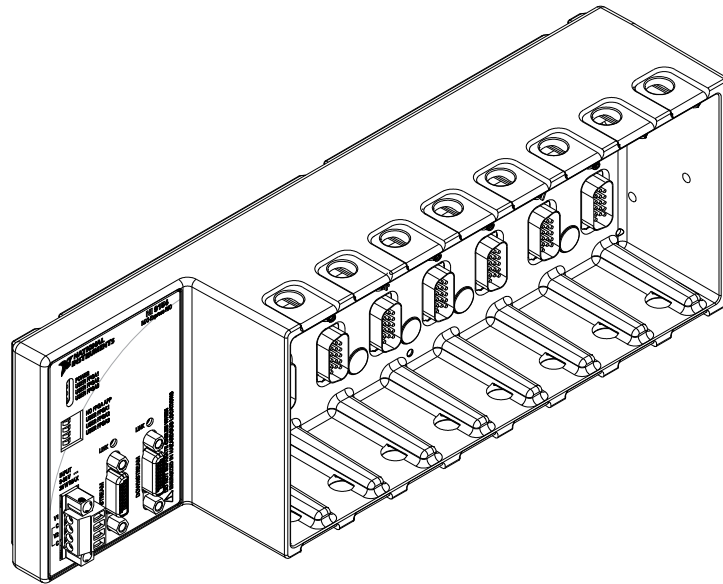

Safety Guidelines



Caution Observe all instructions and cautions in the user documentation. Using the model in a manner not specified can damage the model and compromise the built-in safety protection. Return damaged models to NI for repair.



Attention Suivez toutes les instructions et respectez toutes les mises en garde de la documentation utilisateur. L'utilisation d'un modèle de toute autre façon que celle spécifiée risque de l'endommager et de compromettre la protection de sécurité intégrée. Renvoyez les modèles endommagés à NI pour réparation.

Safety Guidelines for Hazardous Locations

The NI-9154 is suitable for use in Class I, Division 2, Groups A, B, C, D, T4 hazardous locations; Class I, Zone 2, AEx nA IIC T4 Gc and Ex nA IIC T4 Gc hazardous locations; and nonhazardous locations only. Follow these guidelines if you are installing the NI-9154 in a potentially explosive environment. Not following these guidelines may result in serious injury or death.



Caution Do not disconnect the power supply wires and connectors from the controller unless power has been switched off.



Caution Do not disconnect I/O-side wires or connectors unless power has been switched off or the area is known to be nonhazardous.



Caution Do not remove modules unless power has been switched off or the area is known to be nonhazardous.



Caution Substitution of components may impair suitability for Class I, Division 2, or Zone 2.



Caution The system must be installed in an enclosure certified for the intended hazardous (classified) location, having a tool secured cover/door, where a minimum protection of at least IP54 is provided.

Special Conditions for Hazardous Locations Use in Europe and Internationally

The NI-9154 has been evaluated as Ex nA IIC T4 Gc equipment under DEMKO 12ATEX 1202658X and is IECEx UL 14.0089X certified. Each device is marked  II 3G and is suitable for use in Zone 2 hazardous locations, in ambient temperatures of $0\text{ }^{\circ}\text{C} \leq T_a \leq 55\text{ }^{\circ}\text{C}$.



Caution Transient protection shall be provided that is set at a level not exceeding 140% of the peak rated voltage value of 85 V at the supply terminals to the equipment.



Caution The system shall only be used in an area of not more than Pollution Degree 2, as defined in IEC/EN 60664-1.



Caution The system shall be mounted in an ATEX/IECEx-certified enclosure with a minimum ingress protection rating of at least IP54 as defined in IEC/EN 60079-15.



Caution The enclosure must have a door or cover accessible only by the use of a tool.

Electromagnetic Compatibility Guidelines

This product was tested and complies with the regulatory requirements and limits for electromagnetic compatibility (EMC) stated in the product specifications. These requirements and limits provide reasonable protection against harmful interference when the product is operated in the intended operational electromagnetic environment.

This product is intended for use in industrial locations. However, harmful interference may occur in some installations, when the product is connected to a peripheral device or test object, or if the product is used in residential or commercial areas. To minimize interference with radio and television reception and prevent unacceptable performance degradation, install and use this product in strict accordance with the instructions in the product documentation.

Furthermore, any changes or modifications to the product not expressly approved by National Instruments could void your authority to operate it under your local regulatory rules.

Special Conditions for Marine Applications

Some products are approved for marine (shipboard) applications. To verify marine approval certification for a product, visit ni.com/product-certifications, search by model number, and click the appropriate link.



Notice In order to meet the EMC requirements for marine applications, install the product in a shielded enclosure with shielded and/or filtered power and input/output ports. In addition, take precautions when designing, selecting, and installing measurement probes and cables to ensure that the desired EMC performance is attained.

Preparing the Environment

Ensure that the environment in which you are using the NI-9154 meets the following specifications.

Operating temperature (IEC 60068-2-1, IEC 60068-2-2)	0 °C to 55 °C
Operating humidity (IEC 60068-2-78)	10% RH to 90% RH, noncondensing
Pollution Degree	2
Maximum altitude	2,000 m

Indoor use only.



Note Refer to the device specifications on ni.com/manuals for complete specifications.

What You Need to Install the NI-9154

- NI-9154 reconfigurable embedded chassis with integrated MXI-Express (x1)
- One of the following MXI-Express (x1) host systems:
 - PXI system with MXI-Express device installed
 - PC with MXI-Express PCI or PCIe device installed
 - NI Industrial Controller

- NI cRIO-9081/9082 integrated system



Note

The NI-9154 requires a host system with a PCI Express clock that complies with the **PCI Express Specification**. The NI-9154 may not be compatible with systems using noncompliant clocks, particularly clocks with peak frequencies higher than 100 MHz. For more information about PCI Express clock compatibility with the NI-9154, go to ni.com/info and enter the Info Code 915xclock.

- C Series I/O modules
- MXI-Express (x1) cable(s) up to 7 m long
- DIN rail mount kit (for DIN rail mounting only)
- Panel mount kit (for panel mounting only)
- Three M4 or number 8 panhead screws (for mounting the chassis without one of the listed mounting kits)
- Number 2 Phillips screwdriver
- Power supply
- **MXI-Express (x1) Series User Manual**



Note Visit ni.com/info and enter the Info Code rdsoftwareversion to determine which software you need to use the NI-9154.

Installing C Series Modules

The following figure shows the mechanical dimensions of C Series I/O modules.

Figure 1. C Series I/O Module, Front and Side View with Dimensions

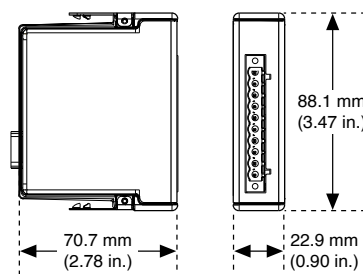

Complete the following steps to install a C Series I/O module in the chassis.

1. Make sure that no I/O-side power is connected to the I/O module. If the system is in a nonhazardous location, the chassis power can be on when you install I/O modules.
2. Align the I/O module with an I/O module slot in the chassis. The module slots are labeled 1 to 8, left to right.

Figure 2. Installing an I/O Module in the Chassis

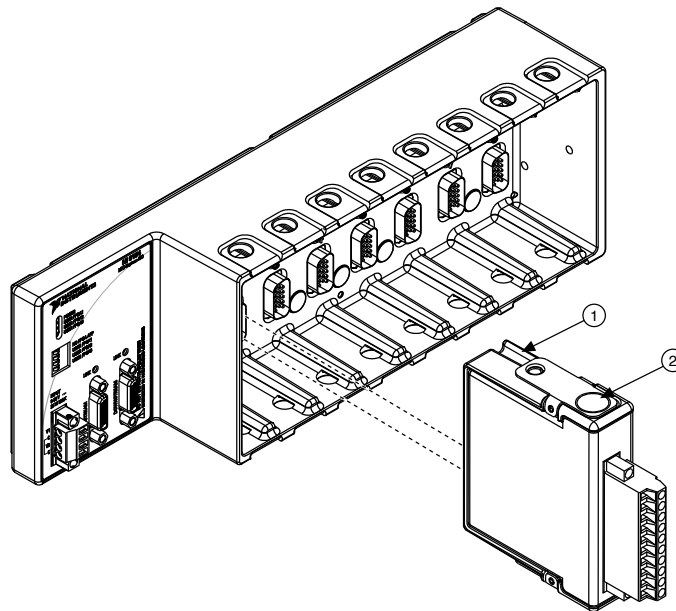

1. Insertion Groove
2. Latch
3. Squeeze the latches and insert the I/O module into the module slot.
4. Press firmly on the connector side of the I/O module until the latches lock the I/O module into place.
5. Repeat these steps to install additional I/O modules.

Removing C Series Modules

Complete the following steps to remove a C Series I/O module from the chassis.

1. Make sure that no I/O-side power is connected to the I/O module. If the system is in a nonhazardous location, the chassis power can be on when you remove I/O modules.
2. Squeeze the latches on both sides of the module and pull the module out of the chassis.

Connecting the NI 9154 to Ground

You must connect the NI 9154 grounding terminal to the grounding electrode system of the facility.

What to Use

- Ring lug
- Wire, 2.05 mm² (12 AWG) or larger
- Screwdriver, Phillips #2

What to Do

Complete the following steps to ground the NI 9154.

1. Attach the ring lug to the wire.
2. Remove the grounding screw from the grounding terminal on the NI 9154.
3. Attach the ring lug to the grounding terminal.
4. Tighten the grounding screw to 0.5 N · m (4.4 lb · in.) of torque.
5. Attach the other end of the wire to the grounding electrode system of your facility using a method that is appropriate for your application.



Caution If you use shielded cabling to connect to a C Series module with a plastic connector, you must attach the cable shield to the chassis grounding terminal using 1.3 mm diameter (16 AWG) or larger wire. Attach a ring lug to the wire and attach the wire to the chassis grounding

terminal. Solder the other end of the wire to the cable shield. Use shorter wire for better EMC performance.

For more information about ground connections, visit ni.com/info and enter the Info Code emcground.

Connecting One or More NI-9154 Chassis to the MXI-Express Host System or a Target

Complete the following steps to connect one or more NI-9154 chassis to a MXI-Express host system or a target.

1. Make sure the MXI-Express host system is set up and configured as described in the **MXI-Express (x1) Series User Manual**.
2. If the MXI-Express host system is powered up, power it down.
3. If the NI-9154 is powered up, power it down.
4. Use a MXI-Express (x1) cable to connect the MXI-Express host system to the Upstream port of the first NI-9154 in the chain.
5. Use a MXI-Express (x1) cable to connect the Downstream port of the first NI-9154 to the Upstream port of the next NI-9154 in the chain.



Note The maximum number of NI-9154 chassis in a chain depends on the system configuration. For example, a PXI system with an NI PXI-8196 controller can support four chassis per chain. Different types of systems may support more or fewer chassis per chain. For more information about how different system configurations can affect the maximum number of chassis in a chain, go to ni.com/info and enter the Info Code 915xchain.

6. Power up all of the connected NI-9154 chassis.
7. Power up the MXI-Express host system.



Note Refer to the **MXI-Express (x1) Series User Manual** for connectivity options and supported host devices.



Caution All connected NI-9154 chassis must have power connected before the host system is powered up. The BIOS and OS of the host system must detect all bus segments on the chassis side in order to configure the PCI hierarchy. Powering connected chassis up or down while the host system is running can cause system hangs and data corruption.



Caution Do not remove MXI-Express (x1) cables while power is connected. Doing so can cause hangs or application errors. If a cable becomes unplugged, plug it back in and reboot.

Wiring Power to the Chassis

The NI-9154 requires an external power supply that meets the specifications. The NI-9154 filters and regulates the supplied power and provides power for all of the I/O modules. You must connect a power supply to at least one pair of V and C terminals. Optionally, you can connect a second power supply to the other pair of V and C terminals. The chassis draws power from the power supply with the higher voltage. The NI-9154 has one layer of reverse-voltage protection. Complete the following steps to connect a power supply to the chassis.

1. Connect the positive lead of the power supply to the V1 or V2 terminal of the COMBICON connector shipped with the NI-9154.
2. Connect the negative lead of the power supply to one of the C terminals of the COMBICON connector.
3. Optionally you can connect the positive lead of another power supply to the other V terminal and the negative lead to one of the C terminals.
4. Install the COMBICON connector on the front panel of the NI-9154.

Chassis Powerup Options

The following table lists the reset options available for the NI-9154. These options determine how the chassis behaves when it is powered on in various conditions. Use the RIO Device Setup utility to select reset options. Access the RIO Device Setup

utility by selecting Start»All Programs»National Instruments»NI-RIO»RIO Device Setup.

Powerup Option	Behavior
Do Not Autoload VI	Does not load the FPGA bit stream from flash memory.
Autoload VI on device powerup	Loads the FPGA bit stream from flash memory to the FPGA when the chassis powers on.

Table 2. Chassis Powerup Options

If you want the NI-9154 to autoload and run a VI at powerup, you must also configure the VI to autoload before you compile it. For more information about autoloading VIs, refer to the **LabVIEW FPGA Module Help**.

Checking MXI-Express LINK LEDs for Status

After powering on the chassis and host system, check the MXI-Express LINK LEDs to ensure that all connected systems are linked and communicating properly. The MXI-Express LINK LEDs of the NI-9154 indicate the following:

LINK LED Appearance	Meaning
Off	Chassis power is off.
Solid yellow	Link is not established.
Solid green	Link is established.
Blinking yellow	PCI Express clock is incompatible with NI-9154

Table 2. NI-9154 MXI-Express LINK LED Indications



Note For information about PCI Express clock compatibility with the NI-9154, go to ni.com/info and enter the Info Code 915xclock.

Powering Down the MXI-Express System

Always power down the host system before powering down any connected NI-9154 chassis. When the host system is powered down, the order in which the NI-9154 chassis are powered down is not important.

Where to Go Next

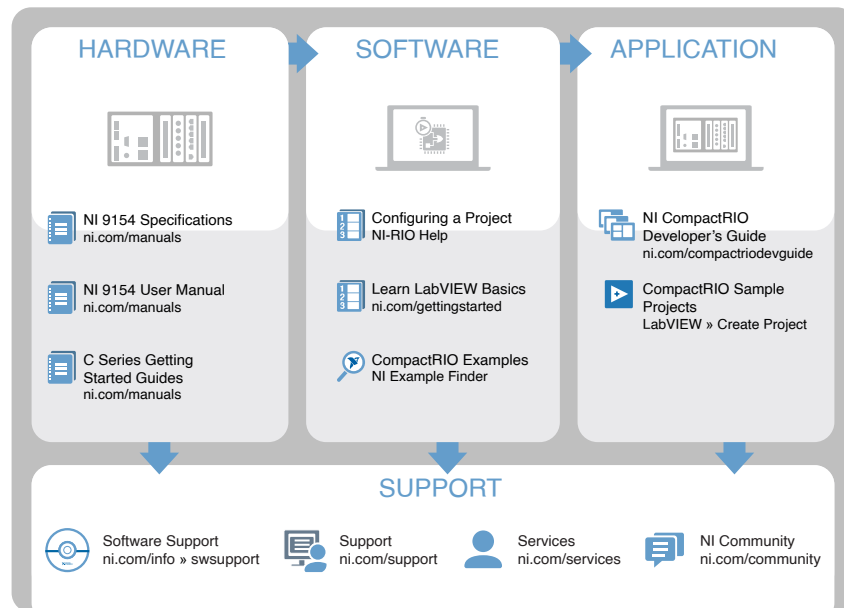

NI Services

Visit ni.com/support to find support resources including documentation, downloads, and troubleshooting and application development self-help such as tutorials and examples.

Visit ni.com/services to learn about NI service offerings such as calibration options, repair, and replacement.

Visit ni.com/register to register your NI product. Product registration facilitates technical support and ensures that you receive important information updates from NI.

NI corporate headquarters is located at 11500 N Mopac Expwy, Austin, TX, 78759-3504, USA.