NI-9216

Specifications

2022-07-06



Contents

NI-9216 Datasheet.....	3
NI-9216 Specifications.....	7

NI-9216 Datasheet

- DSUB or spring terminal connectivity
- 50 Hz/60 Hz noise rejection
- 250 V RMS, CAT II, channel-to-earth isolation (spring terminal); 60 V DC, CAT I, channel-to-earth isolation (DSUB)

The NI-9216 RTD analog input C Series module features eight channels and 24 bits of resolution for PT100 RTD measurements. The NI-9216, compatible with 3- and 4-wire RTD measurements, automatically detects the type of RTD (3- or 4-wire) connected to the channel and configures each channel for the appropriate mode. The module provides 1 mA of current excitation per channel and has less than a ± 1.0 °C accuracy error over its entire operating temperature range. NI provides calibration services for the NI-9216.

Product Name	Module Type	Signal Ranges	Channels	Max Sample Rate	Simultaneous	Resolution	Connectivity
NI 9216	PT100 RTD	0 to 400 Ω	8	400 S/s	No	24-Bit	Spring-Terminal and DSUB
NI 9217	PT100 RTD	0 to 400 Ω	4	400 S/s	No	24-Bit	Screw-Terminal
NI 9219	Universal	0 to 10000 Ω	4	100 S/s	Yes	24-Bit	Spring-Terminal
NI 9226	PT1000 RTD	0 to 4000 Ω	8	400 S/s	No	24-Bit	Spring-Terminal and DSUB

NI C Series Overview



NI provides more than 100 C Series modules for measurement, control, and communication applications. C Series modules can connect to any sensor or bus and allow for high-accuracy measurements that meet the demands of advanced data acquisition and control applications.

- Measurement-specific signal conditioning that connects to an array of sensors and signals
- Isolation options such as bank-to-bank, channel-to-channel, and channel-to-earth ground
- -40 °C to 70 °C temperature range to meet a variety of application and environmental needs
- Hot-swappable

The majority of C Series modules are supported in both CompactRIO and CompactDAQ platforms and you can move modules from one platform to the other with no modification.

CompactRIO



CompactRIO combines an open-embedded architecture with small size, extreme ruggedness, and C Series modules in a platform powered by the NI LabVIEW reconfigurable I/O (RIO) architecture. Each system contains an FPGA for custom timing, triggering, and processing with a wide array of available modular I/O to meet any embedded application requirement.

CompactDAQ

CompactDAQ is a portable, rugged data acquisition platform that integrates connectivity, data acquisition, and signal conditioning into modular I/O for directly interfacing to any sensor or signal. Using CompactDAQ with LabVIEW, you can easily customize how you acquire, analyze, visualize, and manage your measurement data.



Software

LabVIEW Professional Development System for Windows



- Use advanced software tools for large project development
- Generate code automatically using DAQ Assistant and Instrument I/O Assistant
- Use advanced measurement analysis and digital signal processing
- Take advantage of open connectivity with DLLs, ActiveX, and .NET objects
- Build DLLs, executables, and MSI installers

NI LabVIEW FPGA Module

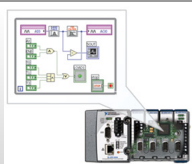

- Design FPGA applications for NI RIO hardware
- Program with the same graphical environment used for desktop and real-time applications
- Execute control algorithms with loop rates up to 300 MHz
- Implement custom timing and triggering logic, digital protocols, and DSP algorithms
- Incorporate existing HDL code and third-party IP including Xilinx IP generator functions
- Purchase as part of the LabVIEW Embedded Control and Monitoring Suite

NI LabVIEW Real-Time Module

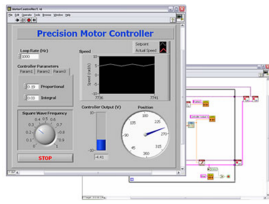

- Design deterministic real-time applications with LabVIEW graphical programming
- Download to dedicated NI or third-party hardware for reliable execution and a wide selection of I/O
- Take advantage of built-in PID control, signal processing, and analysis functions
- Automatically take advantage of multicore CPUs or set processor affinity manually
- Take advantage of real-time OS, development and debugging support, and board support
- Purchase individually or as part of a LabVIEW suite

Input Circuitry

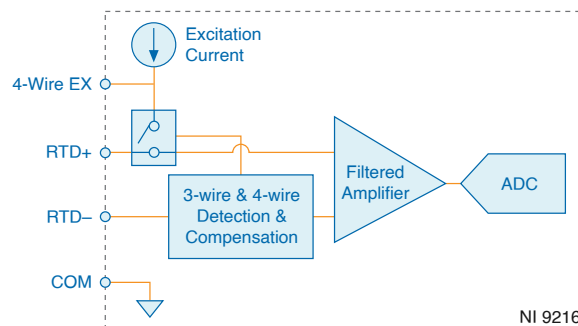

- RTD channels share a common ground that is isolated from other modules in the system.
- Each RTD channel is filtered and then sampled by a 24-bit analog-to-digital converter (ADC).

NI-9216 Specifications

The following specifications are typical for the range -40 °C to 70 °C unless otherwise noted.



Caution Do not operate the NI-9216 in a manner not specified in this document. Product misuse can result in a hazard. You can compromise the safety protection built into the product if the product is damaged in any way. If the product is damaged, return it to NI for repair.

Input Characteristics

Number of channels	8 analog input channels
ADC resolution	24 bits
Type of ADC	Delta-sigma
Sampling mode	Scanned
Measurement range	
Temperature	-200 °C to 850 °C
Resistance	0 Ω to 400 Ω
Conversion time	
High-resolution mode	200 ms per channel, 1,600 ms total for all channels
High-speed mode	2.5 ms per channel, 20 ms total for all channels

Measured Value	Typical (25 °C)	Maximum (-40 °C to 70 °C)
-200 °C to 150 °C	±0.15 °C	±0.4 °C
150 °C to 850 °C	±0.20 °C	±1.0 °C

Table 1. Temperature Accuracy (including noise)^[1], 4-wire mode

Measured Value	Typical (25 °C)	Maximum (-40 °C to 70 °C)
-200 °C to 150 °C	±0.20 °C	±0.5 °C
150 °C to 850 °C	±0.30 °C	±1.0 °C

Table 2. Temperature Accuracy (including noise)^[1], 3-wire mode^[2]

Measurement Conditions	Offset Error	Gain Error
Typical (25 °C)	±0.006 Ω	±0.007%
Maximum (-40 °C to 70 °C)	±0.083 Ω	±0.048%

Table 3. Resistance measurement accuracy (including noise)^[3], 4-wire mode

Measurement Conditions	Offset Error	Gain Error
Typical (25 °C)	±0.012 Ω	±0.007%
Maximum (-40 °C to 70 °C)	±0.101 Ω	±0.048%

Table 4. Resistance measurement accuracy (including noise)^[3], 3-wire mode

Mode	Offset Drift	Gain Drift
4-wire	±3 mΩ/°C	±7 ppm/°C
3-wire	±3.3 mΩ/°C	±7 ppm/°C

Table 5. Stability

Noise	
High-resolution mode	0.001 °C RMS (0.3 mΩ RMS)
High-speed mode	0.02 °C RMS (6 mΩ RMS)
Excitation current	1 mA per channel
Noise rejection	

Normal mode (50/60 Hz)	
High-resolution mode	85 dB
High-speed mode	None
Common-mode rejection, channel-to-earth ground (50/60 Hz)	
High-resolution mode	>170 dB
High-speed mode	122 dB
Input bandwidth (high-resolution mode)	3.3 Hz

Figure 1. High-Resolution Filter Response^{[4], [5]}

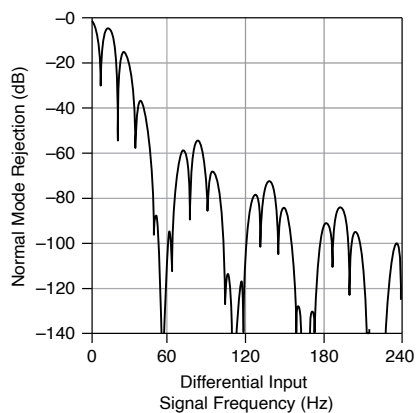

Overvoltage protection	±30 V, maximum
------------------------	----------------

Power Requirements

Power consumption from chassis, maximum	
Active mode	517 mW

Sleep mode	90 μ W
Thermal dissipation, maximum	
Active mode	1.48 W
Sleep mode	0.76 W

Physical Characteristics

Spring-terminal wiring	
Gauge	copper conductor wire
Wire strip length	of insulation stripped from the end
Temperature rating	
Wires per spring terminal	
Connector securement	
Securement type	Screw flanges provided
Torque for screw flanges	
Weight	
NI-9216 with spring terminal	161 g (5.7 oz)
NI-9216 with DSUB	156 g (5.5 oz)

Safety Voltages

Connect only voltages that are within the following limits.

NI-9216 with Spring Terminal Isolation Voltages

Channel-to-channel	None
Channel-to-earth ground	
Continuous	250 Vrms, Measurement Category II
Withstand	3,000 Vrms, verified by a 5 s dielectric withstand test

NI-9216 with DSUB Safety Voltages

Connect only voltages that are within the following limits.

Channel-to-channel	None
Channel-to-earth ground	
Continuous	60 V DC, Measurement Category I
Withstand up to 3,000 m	1,000 V RMS, verified by a 5 s dielectric withstand test
Withstand up to 5,000 m	860 V RMS, verified by a 5 s dielectric withstand test

Hazardous Locations

U.S. (UL)	;
-----------	---

Canada (C-UL)	;
Europe (ATEX) and International (IECEX)	DEMKO ATEX IECEX

Safety Compliance and Hazardous Locations Standards

This product is designed to meet the requirements of the following electrical equipment safety standards for measurement, control, and laboratory use:

- IEC 61010-1, EN 61010-1
- UL 61010-1, CSA C22.2 No. 61010-1
- EN 60079-0, EN 60079-7
- IEC 60079-0, IEC 60079-7
- UL 60079-0, UL 60079-7
- CSA C22.2 No. 60079-0, CSA C22.2 No. 60079-7



Note For safety certifications, refer to the product label or the [Product Certifications and Declarations](#) section.

Electromagnetic Compatibility

CE Compliance

- 2014/34/EU; Potentially Explosive Atmospheres (ATEX)

Product Certifications and Declarations

Refer to the product Declaration of Conformity (DoC) for additional regulatory compliance information. To obtain product certifications and the DoC for NI

products, visit ni.com/product-certifications, search by model number, and click the appropriate link.

Shock and Vibration

To meet these specifications, you must panel mount the system.

Operating vibration	
Random	5 g RMS, 10 Hz to 500 Hz
Sinusoidal	5 g, 10 Hz to 500 Hz
Operating shock	30 g, 11 ms half sine; 50 g, 3 ms half sine; 18 shocks at 6 orientations

Environmental

Refer to the manual for the chassis you are using for more information about meeting these specifications.

Operating temperature (IEC 60068-2-1, IEC 60068-2-2)	-40 °C to 70 °C
Storage temperature (IEC 60068-2-1, IEC 60068-2-2)	-40 °C to 85 °C
Ingress protection (with power plug attached)	IP 40
Operating humidity (IEC 60068-2-78)	10% RH to 90% RH, noncondensing
Storage humidity (IEC 60068-2-78)	5% RH to 95% RH, noncondensing
Pollution Degree	2
Maximum altitude	5,000 m

Indoor use only.

Environmental Management

NI is committed to designing and manufacturing products in an environmentally responsible manner. NI recognizes that eliminating certain hazardous substances from our products is beneficial to the environment and to NI customers.

For additional environmental information, refer to the **Engineering a Healthy Planet** web page at ni.com/environment. This page contains the environmental regulations and directives with which NI complies, as well as other environmental information not included in this document.

EU and UK Customers

-  Waste Electrical and Electronic Equipment (WEEE)—At the end of the product life cycle, all NI products must be disposed of according to local laws and regulations. For more information about how to recycle NI products in your region, visit ni.com/environment/weee.

电子信息产品污染控制管理办法 (中国 RoHS)

-  中国 RoHS— NI 符合中国电子信息产品中限制使用某些有害物质指令(RoHS)。关于 NI 中国 RoHS 合规性信息，请登录 ni.com/environment/rohs_china。(For information about China RoHS compliance, go to ni.com/environment/rohs_china.)

Calibration

You can obtain the calibration certificate and information about calibration services for the NI-9216 at ni.com/calibration.

Calibration interval	1 year
----------------------	--------

- ¹ For high-speed mode, add 0.1 °C of error.
- ² The 3-wire specification assumes equal wire length connecting RTD+ terminal to RTD sensor and COM terminal to RTD sensor. If the lengths are unequal or there is a mismatch between the path resistances, use the following formula to evaluate additional error: °C error = $R_{\text{mismatch}} * 3.42 \text{ } ^\circ\text{C}/\Omega$
- ³ For high-speed mode, add 0.027 Ω of error.
- ⁴ This image is provided courtesy of Linear Technology Corp.
- ⁵ High-speed filter response has the same characteristics as the high-resolution filter response except that the first notch is at 14 kHz.