sbRIO-9697

Getting Started

2022-07-06



Contents

Installation Purpose (RIO Mezzanine Card).....	3
Kit Contents.....	3
Digital I/O Connector Pinouts.....	5
Installing the NI 9697.....	6
Specifications.....	10
3.3 V Digital I/O on 50-Pin IDC Connector.....	10
Physical Characteristics.....	11
Environmental.....	11
Environmental Management.....	11
EU and UK Customers.....	12
电子信息产品污染控制管理办法(中国 RoHS).....	12
Worldwide Support and Services.....	12

Installation Purpose (RIO Mezzanine Card)

The NI 9697 two-slot C Series RIO Mezzanine Card is an accessory you can use to connect up to two board-only C Series modules to the NI sbRIO-9607/9627.

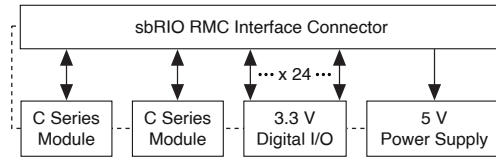

Note NI recommends using the NI 9693 with the NI sbRIO-9605/9606 or the NI sbRIO-9623/9626 as the NI 9697 is not compatible with these products.



Note Board-only C Series modules are represented with an 'E' at the end of the product name. For example, the NI 9219 is the enclosed C Series module and the NI 9219E is the board-only version of the module.

Kit Contents

The NI 9697 kit contains the following components:

Figure 1. Contents of the NI 9697 Kit

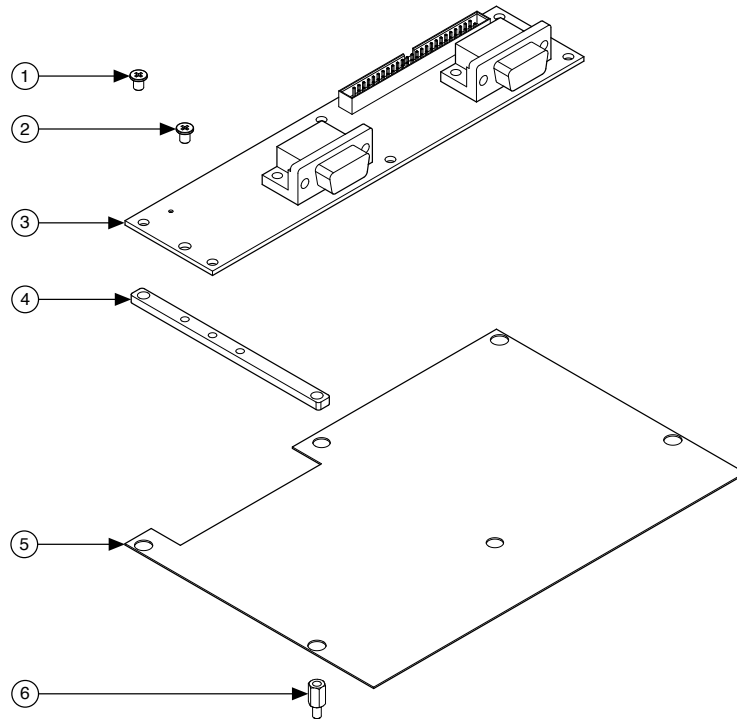

1. M3 × 7 mm Silver Low-Profile Screw (x7)
2. M3 × 4 mm Black Low-Profile Screw (x10)
3. NI 9697
4. C Series Module Support Bracket (x3)
5. Isolator Sheet
6. M3 × 7 mm Standoff (x6)



Caution NI makes no electromagnetic compatibility (EMC) or CE marking compliance claims for the NI 9697. The end-product supplier is responsible for conformity to any and all compliance requirements.



Caution The NI 9697 must be installed inside a suitable enclosure prior to use. Hazardous voltages may be present.



Caution Follow proper ESD precautions to ensure you are grounded before installing hardware.



Caution The protection provided by the NI 9697 can be impaired if the NI 9697 is used in a manner not described in this document.

Digital I/O Connector Pinouts

The following figure shows the pinouts of the I/O connector on the NI sbRIO device.

Figure 2. Pinout of the DIO Connector

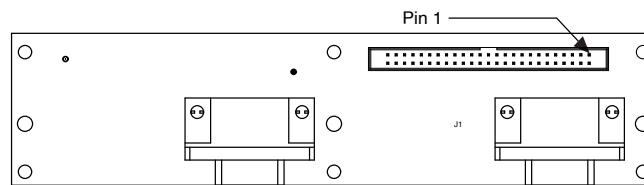

J1, DIO

D GND	1	2	DIO0
D GND	3	4	DIO1
D GND	5	6	DIO2
D GND	7	8	DIO3
D GND	9	10	DIO4
D GND	11	12	DIO5
D GND	13	14	DIO6
D GND	15	16	DIO7
D GND	17	18	DIO8
D GND	19	20	DIO9
D GND	21	22	DIO10
D GND	23	24	DIO11
D GND	25	26	DIO12
D GND	27	28	DIO13
D GND	29	30	DIO14
D GND	31	32	DIO15
D GND	33	34	DIO16
D GND	35	36	DIO17
D GND	37	38	DIO18
D GND	39	40	DIO19
D GND	41	42	DIO20
D GND	43	44	DIO21
D GND	45	46	DIO22
D GND	47	48	DIO23
+5V	49	50	+5V



Note The DIO numbering on this connector corresponds to naming of the DIO on the NI sbRIO device. For example, DIO0 on the NI 9697 connector corresponds to DIO0 on the NI sbRIO-9607/9627 RMC connector.

Installing the NI 9697

What to use:

- Socket driver, 4.5 mm
- Screwdriver, Phillips #1

Complete the following steps to install the NI 9697.

1. Attach the three C Series support brackets to the NI 9697 using six of the M3 × 4 mm black, low-profile screws included in the kit.



Note Do not tighten the screws until you reach step 8. You may need to adjust the brackets during assembly.

Figure 3. Attaching the Support Brackets to the NI 9697

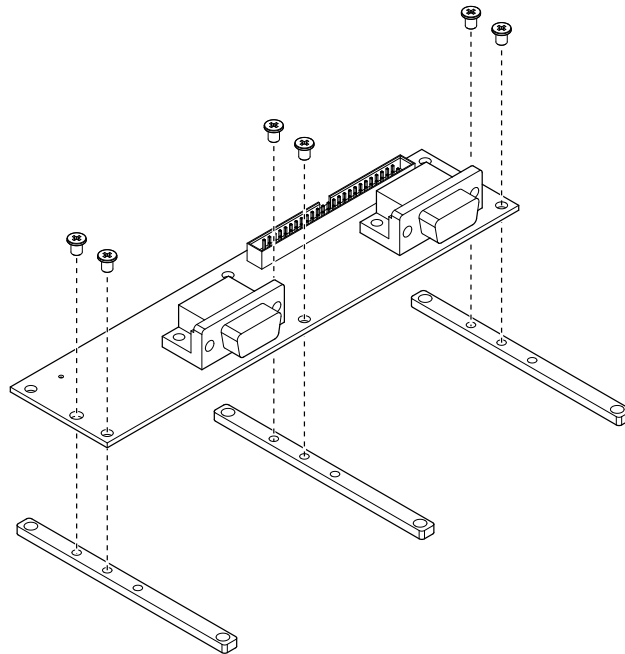

2. Connect board-only C Series modules to the NI 9697.



Caution To avoid causing damage to the NI 9697 and the C Series modules, do not allow C Series module support brackets to contact

components on the secondary side of the board-only C Series modules.

Figure 4. Connecting Board-only C Series Modules to the NI 9697

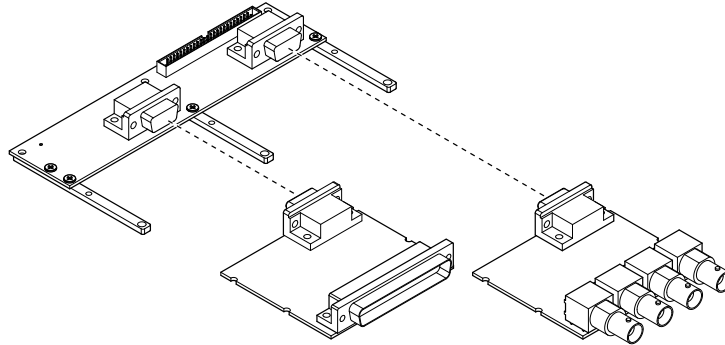

3. Screw three of the remaining M3 × 4 mm black, low-profile screws into the holes.

Figure 5. Inserting Three Screws into the Module and Bracket Holes

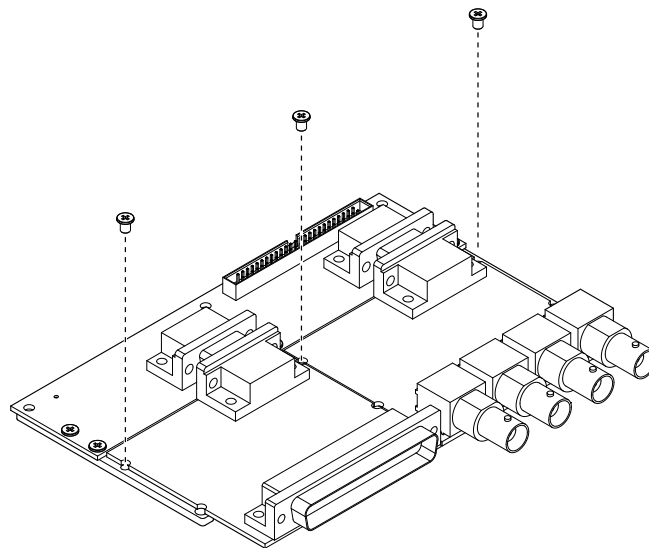

4. Insert the six M3 × 7 mm standoffs from the secondary side of the NI sbRIO device into the six mounting standoffs for your application. The mounting standoffs are not included in the NI 9697 kit.



Note You can attach the NI 9697 to an NI sbRIO-9607. You must support the NI 9697 mounting holes that overhang the NI sbRIO

device with standoffs that are 9.2 mm (0.36 in.) taller than the mounting standoffs described in step 4.

Figure 6. Inserting the Standoffs into the NI sbRIO Device

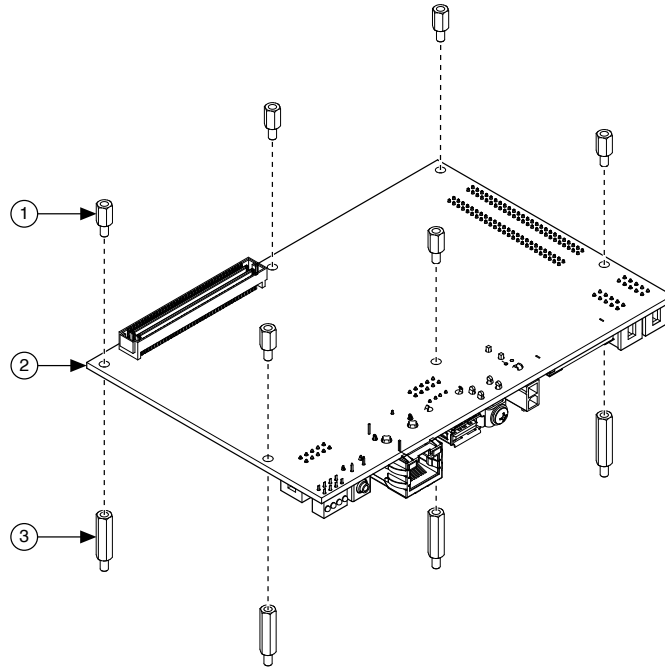

1. M3 × 7 mm Standoff (x6)
 2. sbRIO Device
 3. Mounting Standoff (x6, Not Provided)
5. Tighten the standoffs to 0.45 N · m (4.0 lb · in.). Do not overtighten.
 6. Press the isolator sheet over the standoffs so that 1 mm to 2 mm of standoff protrudes through the holes.
 7. Align the bracket holes attached to the NI 9697 with the tops of the M3 × 7 mm standoffs, and insert the six M3 × 7 mm silver low-profile screws.

Figure 7. Inserting the Standoffs and Screws into the NI sbRIO Device

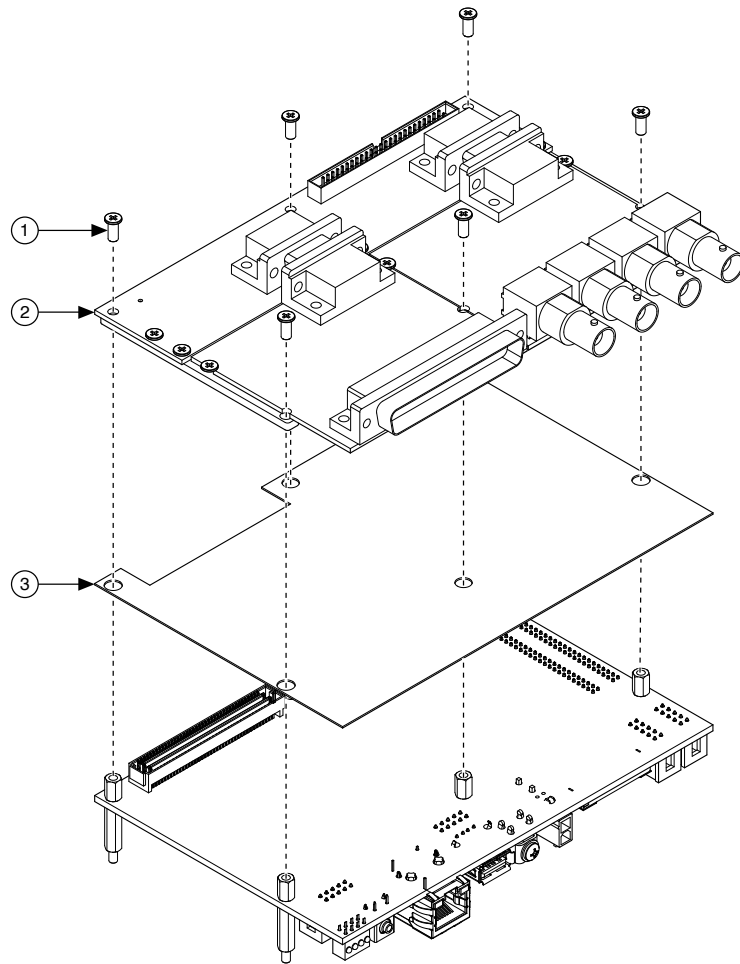

1. M3 × 7 mm Silver Low-Profile Screw (x6)
2. NI 9697
3. Isolator

8. Tighten all the screws to 0.45 N · m (4.0 lb · in.). Do not overtighten.

The following figures show the dimensions of the assembled NI 9697 and NI sbRIO device with two board-only C Series modules.

Figure 8. Side View with Dimensions

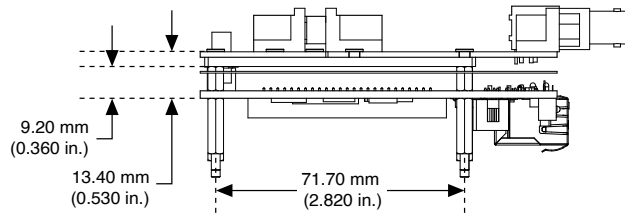
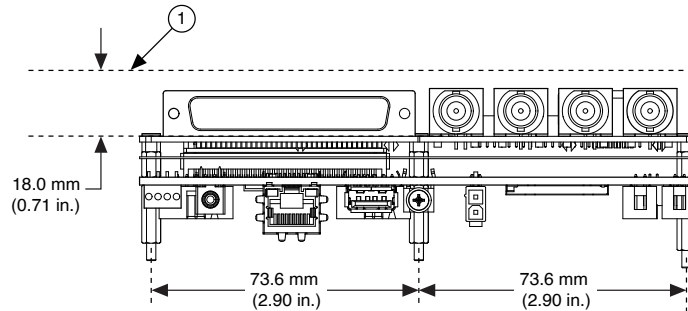

Figure 9. Rear View with Dimensions



1. Recommended Keepaway from Modules



Tip For two-dimensional drawings and three-dimensional models of the NI 9697, visit ni.com/dimensions and search by model number.

Specifications

Refer to the documentation for the NI sbRIO device and the board-only C Series modules for the specifications of those products.

3.3 V Digital I/O on 50-Pin IDC Connector

Number of DIO channels	24
Maximum tested current per channel	±3 mA
Input logic levels	
Input low voltage, V_{IL}	0 V min; 0.8 V max
Input high voltage, V_{IH}	2.0 V min; 5.25 V max

Output logic levels

Output high voltage, V_{OH} when sourcing 3 mA	2.4 V min; 3.465 V max
Output low voltage, V_{OL} when sinking 3 mA	0.0 V min; 0.4 V max

Physical Characteristics

If you need to clean the device, wipe it with a dry towel.

Torque for screws	0.45 N · m (4.0 lb · in)
Weight	82.8 g (2.92 oz)

Environmental

Operating temperature (IEC 60068-2-1, IEC 60068-2-2)	-40 °C to 85 °C
--	-----------------

Thermal validation of an NI sbRIO system assembled with the NI 9697 requires validating the NI sbRIO device and board-only C Series modules. Measure the operating temperature of board-only C Series modules 7.6 mm (0.3 in.) above the module surface. Refer to the documentation of the NI sbRIO device and board-only C Series modules for operating temperature limits and, if applicable, for typical specifications.

Storage temperature (IEC 60068-2-1, IEC 60068-2-2)	-40 °C to 85 °C
Operating humidity (IEC 60068-2-78)	10% RH to 90% RH, noncondensing
Storage humidity (IEC 60068-2-78)	5% RH to 95% RH, noncondensing
Maximum altitude	5,000 m

Indoor use only.

Environmental Management

NI is committed to designing and manufacturing products in an environmentally responsible manner. NI recognizes that eliminating certain hazardous substances from our products is beneficial to the environment and to NI customers.

For additional environmental information, refer to the **Engineering a Healthy Planet** web page at ni.com/environment. This page contains the environmental regulations and directives with which NI complies, as well as other environmental information not included in this document.

EU and UK Customers

-  Waste Electrical and Electronic Equipment (WEEE)—At the end of the product life cycle, all NI products must be disposed of according to local laws and regulations. For more information about how to recycle NI products in your region, visit ni.com/environment/weee.

电子信息产品污染控制管理办法 (中国 RoHS)

-  中国 RoHS—NI 符合中国电子信息产品中限制使用某些有害物质指令 (RoHS)。关于 NI 中国 RoHS 合规性信息，请登录 ni.com/environment/rohs_china。(For information about China RoHS compliance, go to ni.com/environment/rohs_china.)

Worldwide Support and Services

Visit ni.com/support to find support resources including documentation, downloads, and troubleshooting and application development self-help such as tutorials and examples.

Visit ni.com/services to learn about NI service offerings such as calibration options, repair, and replacement.

Visit ni.com/register to register your NI product. Product registration facilitates technical support and ensures that you receive important information updates from NI.

NI corporate headquarters is located at 11500 N Mopac Expwy, Austin, TX, 78759-3504, USA.