

## Chilled Mirror Dew Point/Temperature Transmitter

- Precision accuracy
- Two 4-20mA outputs (configurable)
- Durable and fast responding
- Automatic balance function for the mirror, optical circuitry
- RS232 communication
- Simple maintenance-mirror cleaning
- Applications: HVAC, Clean rooms, Environmental Chambers, Pharmaceutical, Industrial Processes, Glovebox, Semiconductor, Data storage, Hospitals, Museums, Battery systems



### Overview

The CMDP-Series is a family of low-cost dew point chilled mirror transmitter that can be configured as a duct, wall, or pipe unit. The unit offers stable, accurate and repeatable measurements that are traceable to NIST. Available air temperature option is available on the Wall configuration. Settable service cycles for balancing and cleaning the mirror. The CMDP is a primary measurement using a fundamental principle to measure the dew point very accurately. Simple maintenance to cleaning the mirror requires using a wetted cotton swab to restore the transmitter to normal operation. Because of its construction, the customer can enjoy a long life of excellent performance.

### Specifications

<b>Operating Temperature</b>	-40°C to +60°C
<b>Accuracy</b>	± 0.5C
<b>Repeatability</b>	± 0.05C
<b>Calibration</b>	NIST Traceable
<b>Measurement Range</b>	Dew Point -20°C (@ 25°C) to 60°C (non-condensing) Dew Point -40°C (@ 0°C) Temperature probe: (optional) -40°C to 120°C
<b>Output</b>	(2) 4 to 20mA output at 24Vdc (configurable). Default settings: -20°C to 60°C (unless specified on purchase order).
<b>Supply Voltage</b>	24Vdc +/-3V @1.0A
<b>Pressure rating</b>	2 ATM
<b>Resolution</b>	0.01 %
<b>Analog Output scaled range Dew Point (4-20mA) User Selectable</b>	2) 4-20mA -24 Vdc (configurable) Factory set-both outputs, -20C to 60C (unless specified on order)
<b>Air Velocity</b>	50 to 900m/min
<b>Weight</b>	< 5lbs.
<b>Wetted Materials</b>	Nickel, ultem and anodized aluminum

## Dimensions

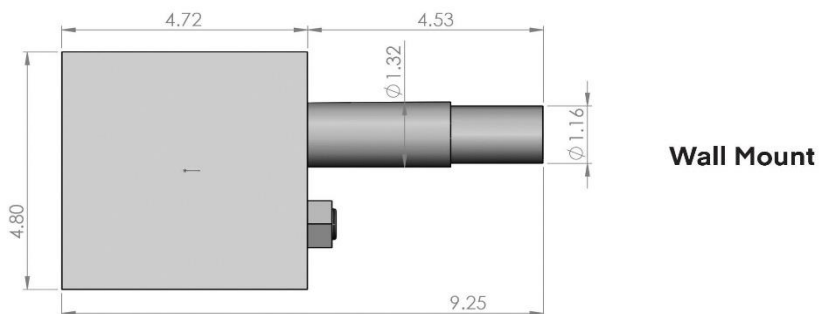
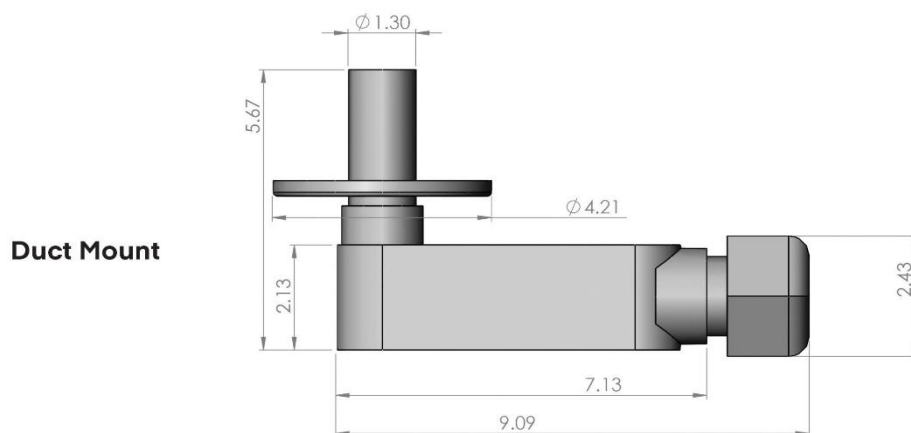
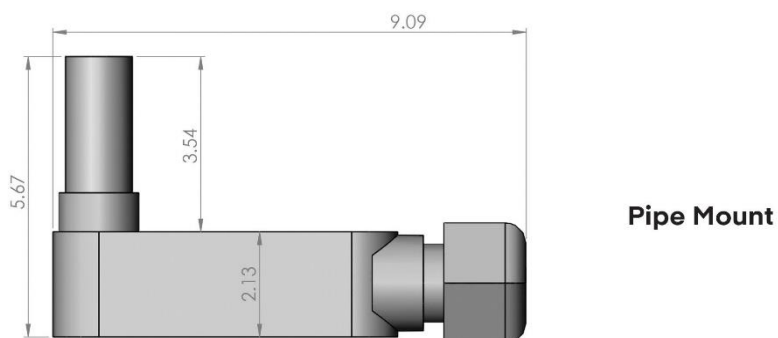

To Order	
Model No.	Description
CMDP-D	Duct Mounted Chilled Mirror Hygrometer (Dewpoint only)
CMDP-W	Wall Mounted Chilled Mirror Hygrometer (Dewpoint only)
CMDPT-W	Wall Mounted Chilled Mirror Hygrometer (Dewpoint/Temperature)
CMDP-P	Pipe Mounted Chilled Mirror Hygrometer (Dewpoint only)