

## Coordinated Circuit Protection Options for LED Lighting

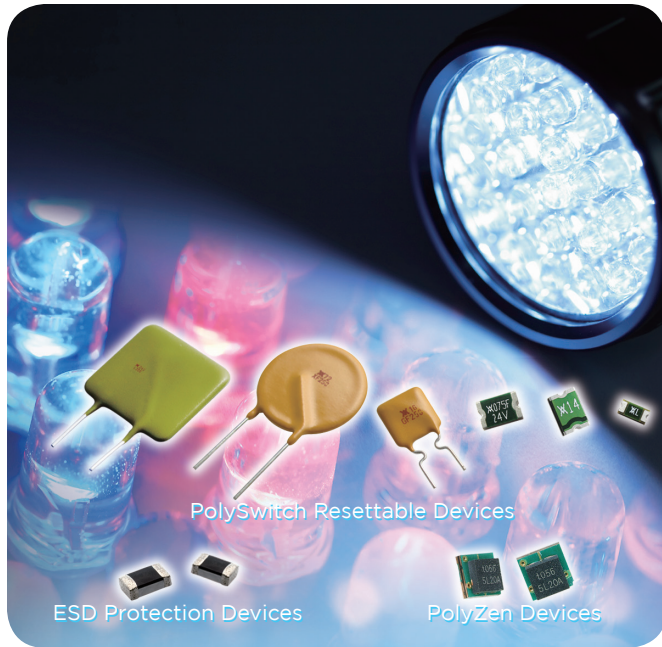

In spite of the growing popularity of the technology, LED light manufacturers continue to wrestle with the fact that LED luminaires are very heat sensitive. Excessive heat or inappropriate applications can dramatically affect performance.

### Heat Conduction Comparisons

A fixture using a 60W incandescent light bulb produces approximately 900 lumens of light and must dissipate 3 Watts of heat via conduction. Using typical DC LEDs as the light source to achieve the same 900 lumens would require about 12 LEDs. Assuming a  $V_f$  (forward voltage) of 3.2V and current of 350mA, the input power to the fixture could be calculated as:

$$\text{Power} = 12 \times 3.2\text{V} \times 350\text{mA} = 13.4\text{W}$$

In this scenario approximately 20% of input power is converted to light and 80% to heat. This is dependent on various factors and heat generation can be related to substrate irregularities, as well as phonon emissions, binding, materials used, etc.

LED technology has advanced rapidly, with improved chip designs and materials facilitating development of brighter and longer-lasting light sources that can be used in a wide spectrum of applications. A growing awareness of the need to reduce energy costs has also made LED lighting increasingly popular. Today, LED lights are quickly replacing conventional lighting based on the following advantages:

- **Low energy consumption**  
retrofit bulbs range from 0.83 to 7.3 watts
- **Long service life**  
LED bulbs can last up to 50,000 hours
- **Durable**  
LED bulbs are resistant to thermal and vibrational shocks and turn on instantly, making them appropriate for applications that are subject to frequent on-off cycling
- **Help meet safety and green initiatives**  
LEDs remain cool to the touch and contain no mercury
- **Fully dimmable**  
LEDs do not change color when dimmed, unlike incandescent lamps that turn yellow
- **No frequency interference**  
no ballast to interfere with radio and television signals

Of the total heat generated by the LED, 90% is transferred via conduction. Figure 1 shows that, to dissipate heat from the junction of an LED, conduction is the principle channel of transfer since convection and radiation only account for about 10% of overall heat transfer. For example, an LED may convert close to 10.72 watts of heat ( $13.4 \times 0.8$ ). Of this, 9.648 Watts ( $10.72 \times 0.9$ ) of heat is transferred or removed from the junction via conduction.

Source	Efficiency (%)	Efficacy (lumens/watts)	Heat Loss (%)		
			Radiation	Convection	Conduction
Incandescent	2	15	90	5	5
Fluorescent	15	90	40	40	20
High Intensity Discharge	20	100	90	5	5
LED	20	75	5	5	90

Figure 1. Heat conduction comparison of various light sources.

Clearly, LED luminaires require precise power and heat-management systems, since most of the electrical energy supplied to an LED is converted to heat rather than light. Without adequate thermal management, this heat can degrade the LED's lifespan and affect color output. Also, since LED

## Coordinated Circuit Protection Options for LED Lighting

drivers are silicon devices, they can fail short. This means fail-safe backup overcurrent protection may be necessary.

### Junction Temperature Effect

The optical behavior of an LED varies significantly with temperature. The amount of light emitted by the LED decreases as the junction temperature rises and, for some technologies, the emitted wavelength changes with temperature. If drive current and junction temperature are not properly managed, the LED's efficiency can drop quickly, resulting in reduced brightness and shortened life.

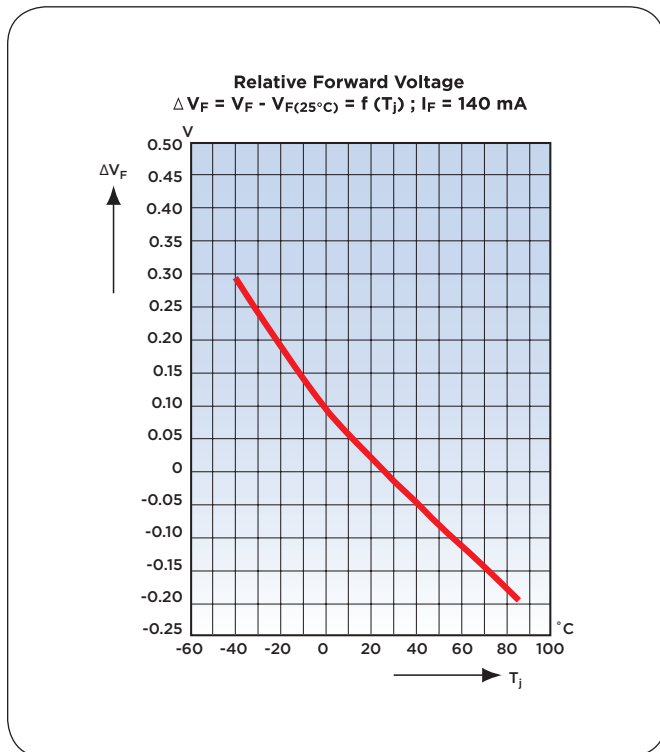

Figure 2. Forward voltage drops as junction temperature rises.

Another LED characteristic, related to junction temperature, is the forward voltage of the LED (Figure 2). If only a simple bias resistor is used to control the drive current,  $V_F$  drops as temperature rises and the drive current increases. This can lead to thermal runaway, especially for high-power LEDs, and cause the component to fail. It is common practice to control junction temperature by mounting the LEDs on metal core PCBs to provide rapid heat transfer.

Power line coupled transients and surges can also reduce LED lifespan and many LED drivers are susceptible to damage resulting from improper DC voltage levels and polarity. LED driver outputs may also be damaged or destroyed by short circuits. Most LED drivers include built-in safety features, including thermal shutdown, as well as open and short LED detection. However, additional overcurrent protection devices may be needed to help protect integrated circuits (ICs) and other sensitive electronic components.

### LED Driver Input and Output Protection

LEDs are driven with a constant current, with the forward voltage varying from less than 2 to 4.5V, depending on the color and current. Older designs relied on simple resistors to limit LED drive current, but designing an LED circuit based on the typical forward voltage drop as specified by a manufacturer can lead to overheating of the LED driver.

This may occur when the forward voltage drop across the LED decreases to a value significantly less than the typical stated value. During such an event, the increased voltage across the LED driver can result in higher total power dissipation from the driver package, which may degrade performance or lifespan.

Today, most LED applications utilize power conversion and control devices to interface with various power sources, such as the AC line, a solar panel or battery power, to control power dissipation from the LED driver. Protecting these interfaces from overcurrent and overtemperature damage is frequently accomplished with resettable Polymeric Positive Temperature Coefficient (PPTC) devices.

As shown in Figure 3, a PolySwitch LVR device can be installed in series with the power input to help protect against damage resulting from electrical shorts, overloaded circuits or customer misuse. Additionally, a Metal Oxide Varistor (MOV) placed across the input helps provide overvoltage protection in the LED module.

The PolySwitch LVR device may also be placed after the MOV. Many equipment manufacturers prefer protection circuits combining resettable PolySwitch devices with upstream fail-safe protection. In this example, R1 is a ballast resistor used in combination with the protection circuit.

## Coordinated Circuit Protection Options for LED Lighting

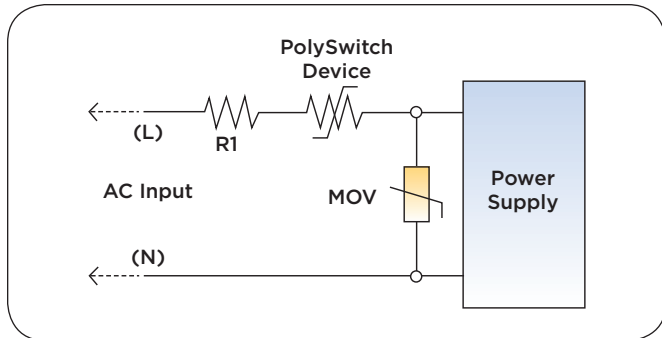

Figure 3. Typical circuit protection design for switch-mode power supplies.

LED drivers may be susceptible to damage resulting from improper DC voltage levels and polarity. Outputs may also be damaged or destroyed by an inadvertent short circuit. Powered ports are also susceptible to damaging overvoltage transients, including ESD pulses.

Figure 4 shows a typical circuit protection design for an LED driver and bulb array. A PolyZen device on the driver input offers designers the simplicity of a traditional clamping diode while obviating the need for significant heat sinking. This device helps provide transient suppression, reverse bias protection, and overcurrent protection in a single, compact package.

A PolySwitch device on the driver output helps protect against damage caused by inadvertent short circuits or other load

anomalies. To fully leverage the PolySwitch device, it can be thermally bonded to the metal core circuit board or LED heat sink. Additionally, a PESD protection device placed in parallel with the LED can help protect against electrostatic discharge (ESD) damage.

### Meeting Class 2 Power Supply Safety Standards

Utilizing a Class 2 power source in a lighting system can be an important factor in reducing the cost and improving the flexibility. Inherently limited power sources – a transformer, power supply, or battery – may include protective devices as long as they are not relied upon to limit the output of the Class 2 supplies.

Non-inherently limited power sources, by definition, have a discrete protective device that automatically interrupts the output when the current and energy output reaches a prescribed limit.

A variety of circuit protection devices can help provide safe operation of Class 2 power sources for LED lighting applications. Figure 5 illustrates how a coordinated circuit protection strategy, employing a MOV on the AC input and a PolySwitch device on an output circuit branch, can help manufacturers meet the requirements of UL 1310 paragraph 35.1 overload test for switches and controls.

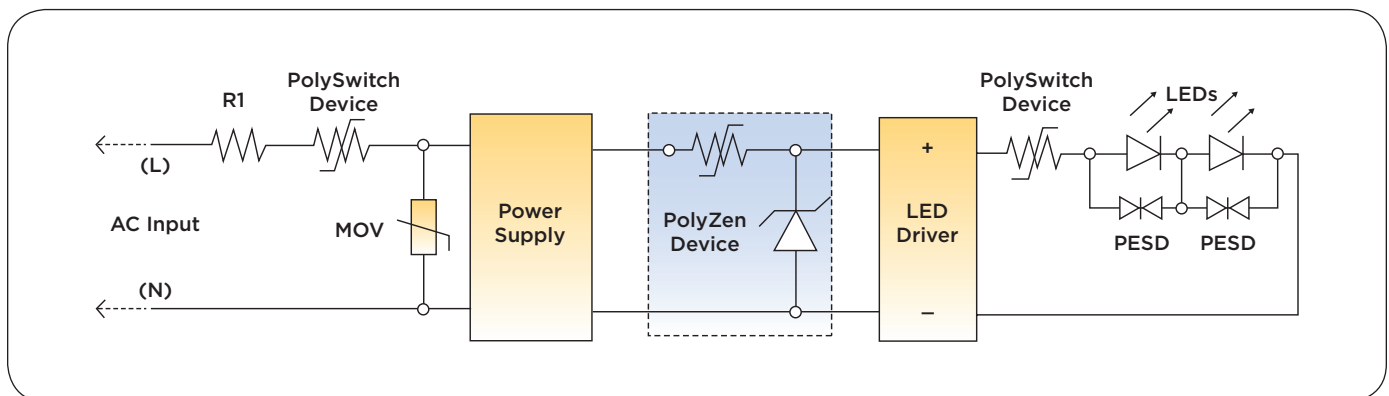

Figure 4. Coordinated protection scheme for LED Driver inputs and outputs.

## Coordinated Circuit Protection Options for LED Lighting

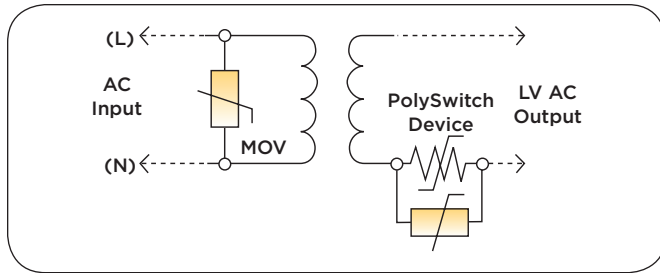

Figure 5. A coordinated protection scheme for Class 2 power sources.

### Summary

Resettable PPTC devices help protect against damage caused by both overcurrent and overtemperature faults in LED lighting applications. MOV overvoltage protection devices help manufacturers meet a number of safety agency requirements, and provide high current-handling and energy absorption capability, as well as fast response to overvoltage transients.

### Definitions of Terms

$V_F$	Voltage drop across the LED in the forward direction. At the point where conduction begins, $V_F$ is about 2V for a red LED and about 3.5V for a blue LED.
$T_J$	Temperature inside the LED, at the PN junction. If this temperature gets too high, the LED will be damaged.
$I_F$	Current through the LED in the forward direction.

PESD devices provide exceptionally low capacitance compared to most ESD protection devices, (0.25pF), and are available in the electronics industry's most popular form factors. The PolyZen device offers designers the simplicity of a traditional clamping diode while obviating the need for significant heat sinking. This single device solution helps provide protection against damage caused by the use of improper power supplies, as well as transient suppression, reverse bias protection, and protection from damage caused by overcurrent events.

Utilizing these devices in a coordinated circuit protection scheme can help designers reduce component count, provide a safe and reliable product, comply with regulatory agency requirements, and reduce warranty and repair costs.

### Notice:

Information furnished is believed to be accurate and reliable. However, users should independently evaluate the suitability of and test each product selected for their own applications. Littelfuse products are not designed for, and shall not be used for, any purpose (including, without limitation, military, aerospace, medical, life-saving, life-sustaining or nuclear facility applications, devices intended for surgical implant into the body, or any other application in which the failure or lack of desired operation of the product may result in personal injury, death, or property damage) other than those expressly set forth in applicable Littelfuse product documentation. Warranties granted by Littelfuse shall be deemed void for products used for any purpose not expressly set forth in applicable Littelfuse documentation. Littelfuse shall not be liable for any claims or damages arising out of products used in applications not expressly intended by Littelfuse as set forth in applicable Littelfuse documentation. The sale and use of Littelfuse products is subject to Littelfuse Terms and Conditions of Sale, unless otherwise agreed by Littelfuse.