



# PXIe-4112 Bundle

Expandable PXI bundle based on PXIe-4112  
PPS, 2 Channels, 60V, 1A

Specifications

***PXIe-1083 and PXIe-4112***

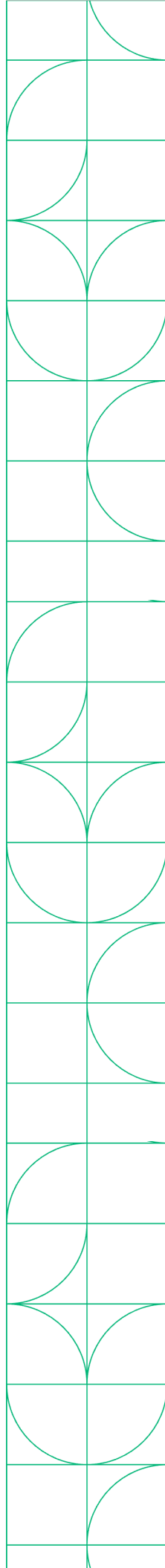

# PXI Programmable Power Supply Bundle

## In the Box



**PXIe-4112**  
Programmable Power Supply



**PXIe-1083**  
(5-Slot PXIe Chassis)

**Accessories:**

- Thunderbolt cable
- Power cable (varied by PN)
  - 867117-01 (US)
  - 867117-02 (EUR)
  - 867117-03 (Generic)

## Recommended Software

**Test Workflow**  
P/N: 788509-35



Test Workflow is a bundle of select NI software featuring engineering-specific tools that help test professionals accomplish anything from their day-to-day work to overcoming their most challenging obstacles.

Test Workflow includes:

- **LabVIEW** - a graphical programming environment engineers use to develop automated research, validation, and production test systems.
- **InstrumentStudio** - an application software that provides an integrated approach to interactive PXI measurements.
- **TestStand** - a test executive software that accelerates system development and deployment for engineers in validation and production.
- And more NI Software!

## Table of Contents

This document combines the PDFs of this bundle together. The page numbers in the table of contents correspond to the page number of PDF the component's documentation begins.

|                               |    |
|-------------------------------|----|
| PXIe-1083 Specifications..... | 3  |
| PXIe-4112 Specifications..... | 16 |



---

# PXIe-1083

## Specifications

---



# PXIe-1083 Specifications

This document contains specifications for the PXIe-1083 chassis.

## Electrical

The following section provides information about the PXIe-1083 AC input and DC output.

### AC Input

|  |  |
|--|--|
| Input rating                           | 100 VAC to 240 VAC, 50 Hz/60 Hz, 6 A to 3 A  |
| Operating voltage range <sup>1</sup>   | 90 VAC to 264 VAC  |
| Nominal input frequency                | 50 Hz/60 Hz  |
| Operating frequency range <sup>1</sup> | 47 Hz to 63 Hz   |
| Efficiency                             | 78% typical  |
| Over-current protection                | Internal fuse in line  |
| Main power disconnect                  | The AC power cable provides main power disconnect. Do not position the equipment so that it is difficult to disconnect the power cord. The front-panel power switch causes the internal chassis power supply to provide DC power to the PXI Express backplane. |



Caution Disconnect power cord to completely remove power.

## DC Output

DC output characteristics of the PXIe-1083.

| Voltage Rail | Maximum Current | Load Regulation | Maximum Ripple and Noise (20 MHz BW) |
|--------------|-----------------|-----------------|--------------------------------------|
| +5V_AUX      | 1.0 A           | ±5%             | 50 mVpp                              |
| +12 V        | 30.1 A          | ±5%             | 120 mVpp                             |
| +5 V         | 25.1 A          | ±5%             | 50 mVpp                              |
| +3.3 V       | 30.7 A          | ±5%             | 50 mVpp                              |
| -12 V        | 0.75 A          | ±5%             | 120 mVpp                             |

Maximum total available power for the PXIe-1083 is 293 W.

The maximum combined power available on +3.3 V and +5 V is 180 W.

The maximum power available for each Thunderbolt port is 15 W (5 V/3 A).

Table 1. Backplane Slot Current Capacity

| Slot   | +5 V | V (I/O) | +3.3 V | +12 V | -12 V | 5 V <sub>AUX</sub> |
|--|------|---------|--------|-------|-------|--------------------|
| Hybrid Peripheral Slot with PXI-5 Peripheral | -    | -       | 3 A    | 6 A   | -     | 1 A                |
| Hybrid Peripheral Slot with PXI-1 Peripheral | 6 A  | 5 A     | 6 A    | 1 A   | 1 A   | -                  |



**Note** PCI V(I/O) pins in Hybrid Peripheral Slots are connected to +5 V.



**Note** The maximum power dissipated in a peripheral slot should not exceed 58 W. Refer to the **Operating Environment** section for ambient temperature considerations at 58 W.

|                         |  |
|-------------------------|--|
| Over-current protection | All outputs are protected from short circuit and overload, they recover and return to regulation when the overload is removed and the power is cycled. |
| Over-voltage protection | +3.3 V clamped at 3.7 V to 4.3 V, +5 V clamped at 5.7 V to 6.5 V, +12 V clamped at 13.4 V to 15.6 V  |

## Chassis Cooling

|   |  |
|---|--|
| Module cooling                            | Forced air circulation (positive pressurization) through one 150 CFM fan |
| Module slot airflow direction             | Bottom of module to top of module  |
| Module intake                             | Bottom of chassis  |
| Module exhaust                            | Top, right side of chassis   |
| Slot cooling capacity                     | 58 W; slot 6 supports 58 W cooling with high fan mode                    |
| Power supply cooling                      | Forced air circulation through integrated fans                           |
| Power supply intake                       | Front and left side chassis  |
| Power supply exhaust                      | Rear of chassis  |
| <b>Minimum chassis cooling clearances</b> |  |
| Above                                     | 44.45 mm (1.75 in.)  |
| Rear                                      | 44.45 mm (1.75 in.)  |
| Sides                                     | 44.45 mm (1.75 in.)  |
| <b>Below</b>                              |  |
| Rack                                      | 44.45 mm (1.75 in.)  |
| Desktop                                   | 25.4 mm (1.00 in.)   |

## Environmental

|                  |   |
|------------------|---|
| Maximum altitude | 2,000 m (6,560 ft.), 800 mbar (at 25 °C ambient, high fan mode) |
| Pollution Degree | 2   |

Indoor use only.

## Operating Environment

|  |                           |
|--|---------------------------|
| <p><b>Ambient temperature range</b></p> <p>When all peripheral modules require <math>\leq 38</math> W cooling capacity per slot</p> <p>0 °C to 50 °C (IEC 60068-2-1 and IEC 60068-2-2.)<sup>2</sup> Meets MIL-PRF-28800F Class 3 low temperature limit and high temperature limit.</p> <p>When any peripheral module requires <math>&gt; 38</math> W cooling capacity per slot</p> <p>0 °C to 40 °C (IEC 60068-2-1 and IEC 60068-2-2.)<sup>2</sup> Meets MIL-PRF-28800F Class 3 low temperature limit and MIL-PRF-28800F Class 4 high temperature limit.</p> |                           |
| Relative humidity range  | 20% to 80%, noncondensing |

## Storage Environment

|                           |  |
|---------------------------|--|
| Ambient temperature range | -40 °C to 71 °C (IEC-60068-2-1 and IEC-60068-2-2.) <sup>[3]</sup> Meets MIL-PRF-28800F Class 3 limits. |
| Relative humidity range   | 10% to 95%, noncondensing  |

## Shock and Vibration

|                              |  |
|------------------------------|--|
| Operational shock            | 30 g peak, half-sine, 11 ms pulse (IEC-60068-2-27.) <sup>3</sup> Meets MIL-PRF-28800F Class 2 limits.  |
| Operational random vibration | 5 to 500 Hz, 0.3 g <sub>rms</sub>  |
| Non-operating vibration      | 5 to 500 Hz, 2.4 g <sub>rms</sub> (IEC 60068-2-64.) <sup>3</sup> Non-operating test profile exceeds the requirements of MIL-PRF-28800F, Class 3. |

## Acoustic Emissions

### Sound Pressure Level (at Operator Position)

(Tested in accordance with ISO 7779. Meets MIL-PRF-28800F requirements.)

|                                |          |
|--------------------------------|----------|
| <b>38 W Profile</b>            |          |
| Auto fan (up to 30 °C ambient) | 33.7 dBA |
| High fan                       | 50.8 dBA |

|                                |          |
|--------------------------------|----------|
| <b>58 W Profile</b>            |          |
| Auto fan (up to 30 °C ambient) | 54.7 dBA |
| High fan                       | 55.3 dBA |

### Sound Power Level

|                     |
|---------------------|
| <b>38 W Profile</b> |
|---------------------|



|                                |          |
|--------------------------------|----------|
| Auto fan (up to 30 °C ambient) | 44.9 dBA |
| High fan                       | 60.3 dBA |

### 58 W Profile

|                                |          |
|--------------------------------|----------|
| Auto fan (up to 30 °C ambient) | 63.4 dBA |
| High fan                       | 64.2 dBA |



**Note** The protection provided by the PXIe-1083 can be impaired if it is used in a manner not described in this document.

## Safety Compliance Standards

This product is designed to meet the requirements of the following electrical equipment safety standards for measurement, control, and laboratory use:

- IEC 61010-1, EN 61010-1
- UL 61010-1, CSA C22.2 No. 61010-1



**Note** For safety certifications, refer to the product label or the [Product Certifications and Declarations](#) section.

## EMC Guidelines

This product was tested and complies with the regulatory requirements and limits for electromagnetic compatibility (EMC) stated in the product specifications. These requirements and limits provide reasonable protection against harmful interference when the product is operated in the intended operational electromagnetic environment.

This product is intended for use in industrial locations. However, harmful interference may occur in some installations, when the product is connected to a peripheral device or test object, or if the product is used in residential areas. To minimize interference with radio and television reception and prevent unacceptable performance degradation, install and use this product in strict accordance with the instructions in the product documentation.

Furthermore, any changes or modifications to the product not expressly approved by NI could void your authority to operate it under your local regulatory rules.

## EMC Notices

Refer to the following notices for cables, accessories, and prevention measures necessary to ensure the specified EMC performance.



### Notice

For EMC declarations and certifications, and additional information, refer to the [Product Certifications and Declarations](#) section.



**Notice** Changes or modifications to the product not expressly approved by NI could void your authority to operate the product under your local regulatory rules.



**Notice** Operate this product only with shielded cables and accessories.

## Electromagnetic Compatibility Standards

This product meets the requirements of the following EMC standards for electrical equipment for measurement, control, and laboratory use:

- EN 61326-1 (IEC 61326-1): Class A emissions; Basic immunity
- EN 55011 (CISPR 11): Group 1, Class A emissions

- AS/NZS CISPR 11: Group 1, Class A emissions



**Note** Group 1 equipment (per CISPR 11) is any industrial, scientific, or medical equipment that does not intentionally generate radio frequency energy for the treatment of material or inspection/analysis purposes.



**Note** In Europe, Canada, Australia, and New Zealand (per CISPR 11) Class A equipment is intended for use in nonresidential locations.

## CE Compliance

This product meets the essential requirements of applicable European Directives, as follows:

- 2014/35/EU; Low-Voltage Directive (safety)
- 2014/30/EU; Electromagnetic Compatibility Directive (EMC)
- 2011/65/EU; Restriction of Hazardous Substances (RoHS)

## Product Certifications and Declarations

Refer to the product Declaration of Conformity (DoC) for additional regulatory compliance information. To obtain product certifications and the DoC for NI products, visit [ni.com/product-certifications](https://ni.com/product-certifications), search by model number, and click the appropriate link.

## Environmental Management

NI is committed to designing and manufacturing products in an environmentally responsible manner. NI recognizes that eliminating certain hazardous substances from our products is beneficial to the environment and to NI customers.

For additional environmental information, refer to the **Engineering a Healthy Planet** web page at [ni.com/environment](https://ni.com/environment). This page contains the environmental

regulations and directives with which NI complies, as well as other environmental information not included in this document.

## EU and UK Customers

-  Waste Electrical and Electronic Equipment (WEEE)—At the end of the product life cycle, all NI products must be disposed of according to local laws and regulations. For more information about how to recycle NI products in your region, visit [ni.com/environment/weee](https://ni.com/environment/weee).

## 电子信息产品污染控制管理办法 ( 中国 RoHS )

-  中国 RoHS— NI 符合中国电子信息产品中限制使用某些有害物质指令(RoHS)。关于 NI 中国 RoHS 合规性信息，请登录 [ni.com/environment/rohs\\_china](https://ni.com/environment/rohs_china)。(For information about China RoHS compliance, go to [ni.com/environment/rohs\\_china](https://ni.com/environment/rohs_china).)

## Backplane

|                               |  |
|-------------------------------|--|
| Size                          | 3U-sized; 5 peripheral slots. Compliant with IEEE 1101.10 mechanical packaging. PXI Express Specification compliant. Accepts both PXI Express and CompactPCI (PICMG 2.0 R 3.0) 3U modules. |
| Backplane bare-board material | UL 94 V-0 Recognized   |
| Backplane connectors          | Conforms to IEC 917 and IEC 1076-4-101, UL 94 V-0 rated  |

## System Synchronization Clocks

10 MHz System Reference Clock: PXI\_CLK10

|                           |  |
|---------------------------|--|
| Maximum slot-to-slot skew | 250 ps   |
| Accuracy                  | $\pm 25$ ppm max (guaranteed over the operating temperature range) |
| Maximum jitter            | 5 ps RMS phase-jitter (10 Hz–1 MHz range)                          |
| Duty-factor               | 45% to 55%   |
| Unloaded signal swing     | 3.3 V $\pm$ 0.3 V  |



Note For other specifications, refer to the **PXI-1 Hardware Specification**.

### 100 MHz System Reference Clock: PXIe\_CLK100 and PXIe\_SYNC100

|  |   |
|--|---|
| Maximum slot-to-slot skew  | 100 ps  |
| Accuracy   | $\pm 25$ ppm max (guaranteed over the operating temperature range)                            |
| Maximum jitter   | 3 ps RMS phase-jitter (10 Hz to 12 kHz range), 2 ps RMS phase-jitter (12 kHz to 20 MHz range) |
| Duty-factor for PXIe_CLK100  | 45% to 55%  |
| Absolute differential voltage (When terminated with a 50 $\Omega$ load to 1.30 V or Thévenin equivalent) | 400 mV to 1000 mV   |



Note For other specifications, refer to the **PXI-5 PXI Express Hardware Specification**.

## Mechanical

| <b>Standard chassis dimensions</b> |   |
|------------------------------------|---|
| Height                             | 177.1 mm (6.97 in.)   |
| Width                              | 257.1 mm (10.12 in.)  |
| Depth                              | 214.2 mm (8.43 in.)   |
| Weight                             | 6.7 kg (14.8 lb)  |
| Chassis materials                  | Extruded Aluminum (6063-T5, 6060-T6), Cold Rolled Steel/Stainless Steel, Santoprene, Urethane Foam, PC-ABS, Nylon, Polyethylene |
| Finish                             | Conductive Clear Iridite on Aluminum, Electroplated Nickel on Cold Rolled Steel, Electroplated Zinc on Cold Rolled Steel        |

The following figures show the PXIe-1083 chassis dimensions. The holes shown are for installing the optional rack mount kits.

Figure 1. PXIe-1083 Chassis Dimensions (Front)

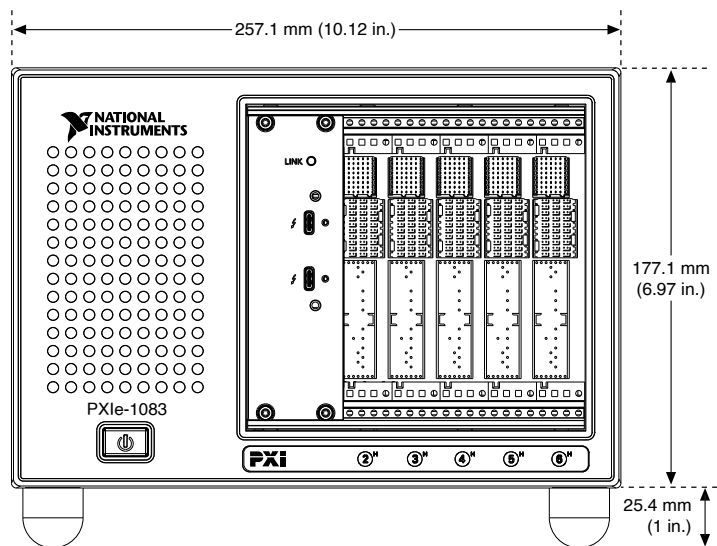

Figure 2. PXIe-1083 Chassis Dimensions (Side)

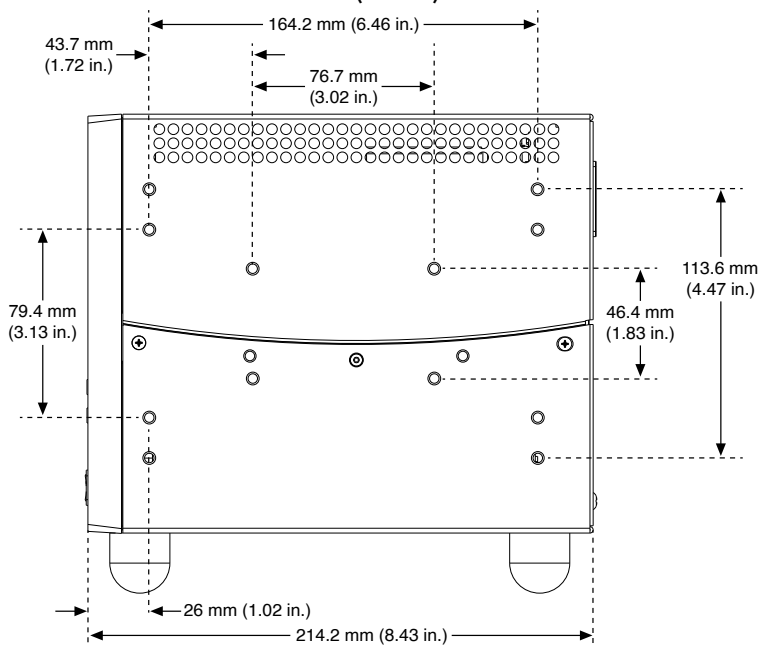
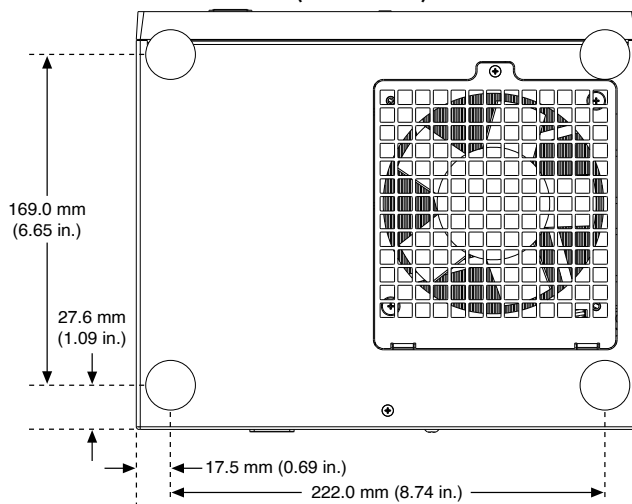

Figure 3. PXIe-1083 Chassis Dimensions (Bottom)



<sup>1</sup> The operating range is guaranteed by design.

<sup>2</sup> This product meets the requirements of the environmental standards for electrical equipment for measurement, control, and laboratory use.

<sup>3</sup> This product meets the requirements of the environmental standards for electrical equipment for measurement, control, and laboratory use.

---

# PXIe-4112

## Specifications

---





# PXIe-4112 Specifications

These specifications apply to the PXIe-4112.

## Definitions

**Warranted** specifications describe the performance of a model under stated operating conditions and are covered by the model warranty.

**Characteristics** describe values that are relevant to the use of the model under stated operating conditions but are not covered by the model warranty.

- **Typical** specifications describe the expected performance met by a majority of the models.
- **Nominal** specifications describe parameters and attributes that may be useful in operation.

## Conditions

Specifications are valid under the following conditions unless otherwise noted.

- Ambient temperature<sup>[1]</sup> of  $23\text{ °C} \pm 5\text{ °C}$
- Calibration interval of 2 years
- 30 minutes warm-up time
- niDCPower Power Line Frequency property or NIDCPOWER\_ATTR\_POWER\_LINE\_FREQUENCY attribute set to 1 power line cycle (PLC)
- niDCPower Samples to Average property or NIDCPOWER\_ATTR\_SAMPLES\_TO\_AVERAGE attribute set to 300 for optimal 50 Hz and 60 Hz rejection
- If the PXI Express chassis has multiple fan speed settings, fans set to the highest setting

## Cleaning the Module

Clean devices and terminal blocks by brushing off light dust with a soft, nonmetallic brush. Remove other contaminants with a soft, lint-free, dampened cloth. Do not use detergent or chemical solvents. The unit must be completely dry and free from contaminants before returning to service.

## Device Capabilities

The PXIe-4112 is a single-quadrant power supply with two output channels that are capable of identical output. Channels are isolated from each other and from chassis ground.

|  |              |
|--|--------------|
| <b>DC voltage</b>                        |              |
| Voltage range                            | 60 V         |
| Minimum programmable voltage level/limit | 0.1 V        |
| <b>DC current</b>                        |              |
| Current range                            | 1 A          |
| Minimum programmable current level/limit | 0.01 A       |
| Output power                             | 60 W/channel |

The following figure illustrates the voltage and the current source capabilities of the PXIe-4112.

Figure 1. PXIe-4112 Quadrant Diagram

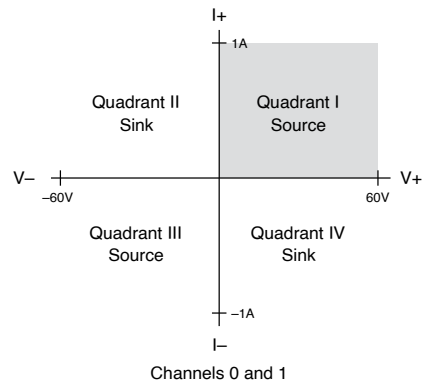

## Programming and Measurement Accuracy/Resolution

| Specification       | Resolution        | Accuracy $\pm$ (% of output + offset), $T_{cal} \pm 5^\circ\text{C}$ | Temperature Coefficient/ $^\circ\text{C}$ , outside $T_{cal} \pm 5^\circ\text{C}$ |
|---------------------|-------------------|--|---|
| Voltage programming | 2 mV              | 0.12% + 55 mV  | 0.008% + 0.3 mV   |
| Voltage measurement | 17 mV             | 0.1% + 50 mV   | 0.004% + 1.5 mV   |
| Current programming | 34 $\mu\text{A}$  | 0.15% + 10 mA  | 0.015% + 0.05 mA  |
| Current measurement | 274 $\mu\text{A}$ | 0.15% + 4 mA   | 0.015% + 0.05 mA  |

Table 1. Programming and Measurement Accuracy/Resolution

## Load Regulation

|                                     |                  |
|-------------------------------------|------------------|
| Voltage (per amp of output load)    | 12 mV            |
| Current (per volt of output change) | 32 $\mu\text{A}$ |

**Note** Voltage load regulation is measured at the output channel terminals with the device configured for local sense.

## Voltage Output Speed

### Rise time (measured from 10% to 90% of programmed voltage change from 0.1 V to 60 V with specified load)

Full resistive load (60  $\Omega$ ) <20 ms, typical

No load <10 ms, typical

### Fall time (measured from 10% to 90% of programmed voltage change from 60 V to 0.1 V with specified load)

Full resistive load (60  $\Omega$ ) <20 ms, typical

No load <40 ms, typical

## Transient Response and Settling Time

|                    |   |
|--------------------|---|
| Transient response | <200 $\mu$ s to recover within 200 mV of voltage level after a load current change from 50% to 100% of current range, typical |
|--------------------|---|

### Settling time

#### Rise time (time to settle within 0.1% of final programmed voltage level from 0.1 V to 60 V with specified load)

Full resistive load (60  $\Omega$ ) 40 ms, typical

No load 40 ms, typical

#### Fall time (time to settle within 0.1% of final programmed voltage level from 60 V to 0.1 V with specified load)

Full resistive load (60  $\Omega$ ) 100 ms, typical

|         |                 |
|---------|-----------------|
| No load | 100 ms, typical |
|---------|-----------------|

## Ripple and Noise

### **Voltage<sup>[5]</sup>**

|              |                 |
|--------------|-----------------|
| Peak-to-peak | <24 mV, typical |
|--------------|-----------------|

|     |                |
|-----|----------------|
| RMS | <4 mV, typical |
|-----|----------------|

|                             |                |
|-----------------------------|----------------|
| Current, RMS <sup>[6]</sup> | <2 mA, typical |
|-----------------------------|----------------|

## Auxiliary Power Input Line Regulation

### **Line regulation (per volt of change in the auxiliary power input)**

|         |      |
|---------|------|
| Voltage | 1 mV |
|---------|------|

|         |        |
|---------|--------|
| Current | 0.2 mA |
|---------|--------|

## Remote Sense

|                          |                         |
|--------------------------|-------------------------|
| Maximum output lead drop | Up to 1 V drop per lead |
|--------------------------|-------------------------|

|                               |                           |
|-------------------------------|---------------------------|
| Maximum sense lead resistance | Up to 1 $\Omega$ per lead |
|-------------------------------|---------------------------|

## Protection

### **Output channel protection**

|                                |  |
|--------------------------------|--|
| Overcurrent or reverse voltage | Reverse clamp diode, protected by thermal overload circuit |
| Overtemperature                | Automatic shutdown   |

### Auxiliary power input protection

|                                |                    |
|--------------------------------|--------------------|
| Overvoltage, typical           | >52.8 VDC shut-off |
| Overcurrent or reverse voltage | Fused              |

## Absolute Maximum Limit

**Note** Applying levels beyond the ratings specified in this section can result in permanent damage to the device.

**Note** Connect only voltages that are within these limits.

|  |        |
|--|--------|
| Voltage from auxiliary power + to earth ground | 60 VDC |
| Voltage from auxiliary power - to earth ground | 1 VDC  |

## Isolation

### Isolation voltage, channels 0- and 1-to-earth ground<sup>[7]</sup>

|            |                        |
|------------|------------------------|
| Continuous | 150 VDC, CAT I         |
| Withstand  | 1,000 V <sub>RMS</sub> |

**Caution** Do not connect to MAINs. Do not connect to signals or use for the measurements within CAT II, III, or IV.

**Note** Measurement Categories CAT I and CAT O (Other) are equivalent. These test and measurement circuits are not intended for direct connection to the MAINs building installations of Measurement Categories CAT II, CAT III, or CAT IV.

**Hazardous Voltage** Take precautions to avoid electrical shock when operating this product at hazardous voltages.

**Note** Isolation voltage ratings apply to the voltage measured between any channel pin and the chassis ground pins of the front panel. When operating channels in series or floating on top of external voltage references, ensure that no terminal exceeds this rating.

## Power Requirement

|   |  |
|---|--|
| PXI power requirement                     | 0.5 A from 3.3 V rail, 0.25 A from 12 V rail |
| Auxiliary power source input requirements | 45.6 VDC to 50.4 VDC, 3.5 A max              |

## Measurement Timing Characteristics

### Measurement rate

Default 60/s (Line frequency set to 60 Hz, aperture set to 1 PLC, measure record mode), nominal

Maximum 5,250/s, nominal

## Triggers

### Input triggers

Types Start, Source, Sequence Advance, Measure

#### Sources (PXI trigger lines 0 to 7)<sup>[8]</sup>

Polarity Configurable

Minimum pulse width 100 ns, nominal

#### Destinations<sup>[9]</sup> (PXI trigger lines 0 to 7)<sup>[8]</sup>

Polarity Active high (not configurable)

Minimum pulse width 200 ns, nominal

### Output triggers (events)

Types Source Complete, Sequence Iteration Complete, Sequence Engine Done, Measure Complete

#### Destinations (PXI trigger lines 0 to 7)<sup>[8]</sup>

Polarity Configurable

Pulse width Configurable between 250 ns and 1.6  $\mu$ s, nominal

## Physical Characteristics

|            |  |
|------------|--|
| Dimensions | 3U, one-slot, PXI Express/cPCI Express module; 2.0 cm $\times$ 13.0 cm $\times$ 21.6 cm (0.8 in. $\times$ 5.1 in. $\times$ 8.5 in.), nominal |
|------------|--|



|  |  |
|--|--|
| Weight   | 443 g, nominal                           |
| User-replaceable fuse, auxiliary power input (PCB-mount) | F 6.3 A H 250 V (5 × 20 mm ceramic fuse) |

**Note** NI recommends the Littelfuse 021606.3MXP fuse.

### Front panel connectors

|                       |  |
|-----------------------|--|
| Output channels       | Phoenix Contact, 5.08 mm (10 position) |
| Auxiliary power input | Weidmuller, 3.5 mm (2 × 2 position)    |

**Note** I/O connectors can accept wire gauges from 12 AWG to 24 AWG. NI recommends 14 AWG or smaller.

**Note** The PXIe-4112 ships with four sense jumpers installed on the output connector. The sense jumpers connect the sense terminals to their respective output terminals.

## Calibration Interval

|                                  |         |
|----------------------------------|---------|
| Recommended calibration interval | 2 years |
|----------------------------------|---------|

## Environment

|                  |   |
|------------------|---|
| Maximum altitude | 2,000 m (800 mbar) (at 25 °C ambient temperature) |
| Pollution Degree | 2   |

Indoor use only.

## Operating Environment

|                           |  |
|---------------------------|--|
| Ambient temperature range | 0 °C to 55 °C (Tested in accordance with IEC 60068-2-1 and IEC 60068-2-2. Meets MIL-PRF-28800F Class 3 low temperature limit and MIL-PRF-28800F Class 2 high temperature limit.) |
| Relative humidity range   | 10% to 90%, noncondensing (Tested in accordance with IEC 60068-2-56.)  |

## Storage Environment

|                           |   |
|---------------------------|---|
| Ambient temperature range | -40 °C to 70 °C (Tested in accordance with IEC 60068-2-1 and IEC 60068-2-2. Meets MIL-PRF-28800F Class 3 limits.) |
| Relative humidity range   | 5% to 95%, noncondensing (Tested in accordance with IEC 60068-2-56.)  |

## Shock and Vibration

|                         |  |
|-------------------------|--|
| Operating shock         | 30 g peak, half-sine, 11 ms pulse (Tested in accordance with IEC 60068-2-27. Meets MIL-PRF-28800F Class 2 limits.)                                 |
| <b>Random vibration</b> |  |
| Operating               | 5 Hz to 500 Hz, 0.3 g <sub>rms</sub> (Tested in accordance with IEC 60068-2-64.)   |
| Nonoperating            | 5 Hz to 500 Hz, 2.4 g <sub>rms</sub> (Tested in accordance with IEC 60068-2-64. Test profile exceeds the requirements of MIL-PRF-28800F, Class 3.) |

## Compliance and Certifications

**Caution** You can impair the protection provided by the PXIe-4112 if you use it in a manner not described in this document.

**Caution** The auxiliary power input port is sensitive to electrostatic discharge (ESD). When subjected to ESD during normal operation, a fault might result that requires user intervention to recover to normal operation. To ensure proper operation, make all I/O connections before attempting to use the device. In addition, take care to prevent ESD to the auxiliary power input port during normal operation.

### Safety

This product is designed to meet the requirements of the following electrical equipment safety standards for measurement, control, and laboratory use:

- IEC 61010-1, EN 61010-1
- UL 61010-1, CSA C22.2 No. 61010-1

**Note** For UL and other safety certifications, refer to the product label or the [Online Product Certification](#) section.

### Electromagnetic Compatibility

This product meets the requirements of the following EMC standards for electrical equipment for measurement, control, and laboratory use:

- EN 61326-1 (IEC 61326-1): Class A emissions; Basic immunity
- EN 55011 (CISPR 11): Group 1, Class A emissions
- EN 55022 (CISPR 22): Class A emissions
- EN 55024 (CISPR 24): Immunity
- AS/NZS CISPR 11: Group 1, Class A emissions

- AS/NZS CISPR 22: Class A emissions
- FCC 47 CFR Part 15B: Class A emissions
- ICES-001: Class A emissions

**Note** In the United States (per FCC 47 CFR), Class A equipment is intended for use in commercial, light-industrial, and heavy-industrial locations. In Europe, Canada, Australia, and New Zealand (per CISPR 11), Class A equipment is intended for use only in heavy-industrial locations.

**Note** Group 1 equipment (per CISPR 11) is any industrial, scientific, or medical equipment that does not intentionally generate radio frequency energy for the treatment of material or inspection/analysis purposes.

**Note** For EMC declarations, certifications, and additional information, refer to the [Online Product Certification](#) section.

## CE Compliance

This product meets the essential requirements of applicable European Directives, as follows:

- 2014/35/EU; Low-Voltage Directive (safety)
- 2014/30/EU; Electromagnetic Compatibility Directive (EMC)

## Online Product Certification

Refer to the product Declaration of Conformity (DoC) for additional regulatory compliance information. To obtain product certifications and the DoC for this product, visit [ni.com/certification](http://ni.com/certification), search by model number or product line, and click the appropriate link in the Certification column.

## Environmental Management

NI is committed to designing and manufacturing products in an environmentally responsible manner. NI recognizes that eliminating certain hazardous substances from our products is beneficial to the environment and to NI customers.

For additional environmental information, refer to the **Minimize Our Environmental Impact** web page at [ni.com/environment](http://ni.com/environment). This page contains the environmental regulations and directives with which NI complies, as well as other environmental information not included in this document.

## Waste Electrical and Electronic Equipment (WEEE)

**EU Customers** At the end of the product life cycle, all NI products must be disposed of according to local laws and regulations. For more information about how to recycle NI products in your region, visit [ni.com/environment/weee](http://ni.com/environment/weee).

## 电子信息产品污染控制管理办法（中国 RoHS）

**中国客户** National Instruments 符合中国电子信息产品中限制使用某些有害物质指令(RoHS)。关于 National Instruments 中国 RoHS 合规性信息，请登录 [ni.com/environment/rohs\\_china](http://ni.com/environment/rohs_china)。(For information about China RoHS compliance, go to [ni.com/environment/rohs\\_china](http://ni.com/environment/rohs_china).)

<sup>1</sup> The ambient temperature of a PXI system is defined as the temperature at the chassis fan inlet (air intake).

<sup>2</sup> Based on 16-bit DAC after calibration

<sup>3</sup> Based on 14-bit ADC with sign bit after calibration

<sup>4</sup>  $T_{cal}$  is the internal device temperature recorded by the PXIe-4112 at the completion of the last external calibration.

<sup>5</sup> Noise is measured from 20 Hz to 20 MHz at output voltages of 0.5 V to 60 V.

<sup>6</sup> Noise bandwidth is limited to 10 kHz and measured at 20 mA into a 500  $\Omega$  load.

<sup>7</sup> Verified with a 5-second dielectric withstand test.

<sup>8</sup> Pulse widths and logic levels are compliant with **PXI Express Hardware Specification Revision 1.0 ECN 1**.

<sup>9</sup> Input triggers can come from any source (PXI trigger or software trigger) and be exported to any PXI trigger line. This allows for easier multi-board synchronization regardless of the trigger source.