

***CUS250M***

**AC/DC Power Supply Series**

***APPLICATION NOTE***



## Contents

Contents .....	2
AC INPUT.....	3
AC Input Line Requirements .....	3
Input Fuses.....	3
Input Under-voltage .....	3
DC OUTPUT .....	3
Output Voltage Adjustment.....	3
Series Connection of Outputs.....	3
Parallel Connection of Outputs.....	3
Grounding of Outputs .....	3
CONNECTIONS.....	4
Input.....	4
Output .....	5
OUTPUT PROTECTION .....	6
No Load Operation .....	6
Over current and Short Circuit Protection .....	6
Over temperature protection.....	7
Over voltage protection .....	7
SIGNALS.....	8
Remote On/Off.....	8
AC FAIL .....	9
DC OK .....	10
OUTPUTS AND SIGNALS TIMING .....	11
Output timing diagram .....	11
EFFICIENCY .....	12
STANDBY POWER (unit inhibited).....	12
LEAKAGE CURRENT CHARACTERISTICS.....	13
Earth Leakage .....	13
Touch Current.....	13
ELECTROLYTIC CAPACITOR LIFETIMES .....	14
COOLING .....	15
Convection and Conduction Cooling .....	15
Forced air Cooling .....	15
PEAK POWER CAPABILITY .....	16
CAPACITIVE LOAD .....	17
RELIABILITY .....	17
ELECTROMAGNETIC COMPATIBILITY.....	18
Installation for Optimum EMC Performance.....	18
Conducted Emissions.....	19
Radiated Emissions.....	20
MECHANICAL.....	21
Weight.....	21
Mounting.....	21

## AC INPUT

### **AC Input Line Requirements**

Please refer to the datasheet for specifications of input line requirements (including input voltage range, input frequency, input harmonics, input current and leakage current).

The power supply will automatically recover from loss of AC power and start up at 85Vac. The output power derating for AC input voltages below 100Vac is 1%/V from 100Vac to 90Vac and 2%/V from 90Vac to 85Vac. The main output may hiccup a few times during start up at low input voltage and low ambient temperature but will start monotonically when any of the following conditions are met:

- ambient temperature is above 0°C
- or AC input voltage is i) above 100Vac for nominal Vout, or ii) above 110Vac for Max Vout
- or when the main output load is below 70% (according to any line derating if applicable)

Load capacitance below the maximum specified will reduce the hiccup occurrence.

Repetitive ON/OFF cycling of the AC input voltage is not recommended.

### **Input Fuses**

Two internal fuses are fitted, one in each AC line. These fuses are not user serviceable. Fuses are rated for 5A and 250VAC.

In the E option, one internal fuse is fitted in the Line (L) connection.

### **Input Under-voltage**

The power supply is protected against the application of an input voltage below the minimum specified so that it shall not cause damage to the power supply. The turn on and off input voltage can significantly vary with the load.

## DC OUTPUT

### **Output Voltage Adjustment**

The output voltage is user adjustable via potentiometer adjacent to the output terminals.

The potentiometer is single turn type and accessible in vertical orientation using a suitable trimmer tool.

Refer to Instruction manual for permitted voltage adjustment range.

### **Series Connection of Outputs**

Please contact Technical Sales for guidance.

### **Parallel Connection of Outputs**

Outputs must not be directly connected in parallel as this may cause overheating and reduced field life.

Paralleling for redundancy possible, contact technical sales.

### **Grounding of Outputs**

The positive or negative DC output terminals can be grounded. When connecting output to ground, it is recommended to make the connection as close as possible between DC output and the power supply chassis ground. This helps to avoid noise problems by potential common-mode currents flowing to ground.

## CONNECTIONS

Refer to outline drawing in product datasheet for connector positions.

### Input

#### AC mains input J1

A 2-way 7.92mm pitch header provides connection for AC input.

Two connector options are available – Molex type with friction lock or JST type with latch.

#### J1 Connector – view from above

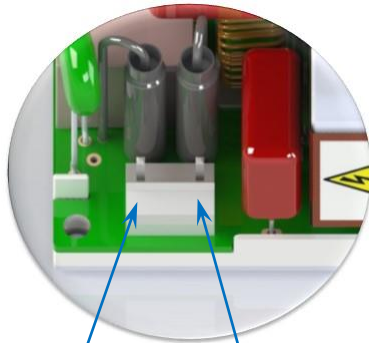

AC Neutral      AC Live

Standard model (JST type connector)	
Mating Housing	JST p/n : VAR-2
Crimp terminal (20-18AWG)	JST p/n : SVA-41T-P1.1
M option (Molex type connector)	
Mating Housing	Molex p/n : 09-50-1031
Crimp terminal (24-18AWG)	Molex p/n : 08-70-1031

Contact with JST and Molex for other crimp terminal types

### Earthing

The CUS250M may be earthed from any of the four corner PCB M3 fixings.

On /U, /A, /F cased models there are also two unmasked slots available in the unit chassis.

Any protective bonding must be verified by the end equipment manufacturer.

Refer to outline drawing(s) in instruction manual for position/dimensions of fixings.

**Output**

**CH1 Output Screw terminals J101, J102**

Two M3 screw terminals are provided for connection to the DC output. Each terminal has vertical and horizontal access positions for the terminal screws. The screws (M3x8 SEM type with integral flat/spring washers and combi head) are factory fitted in the vertical position. Do not use alternate screw types that are longer than the 8mm factory fitted parts. The factory fitted torque is sufficient for transit purposes only. When re-fitting the screws observe maximum torque of 0.6Nm.

J101, J102 Output Terminals

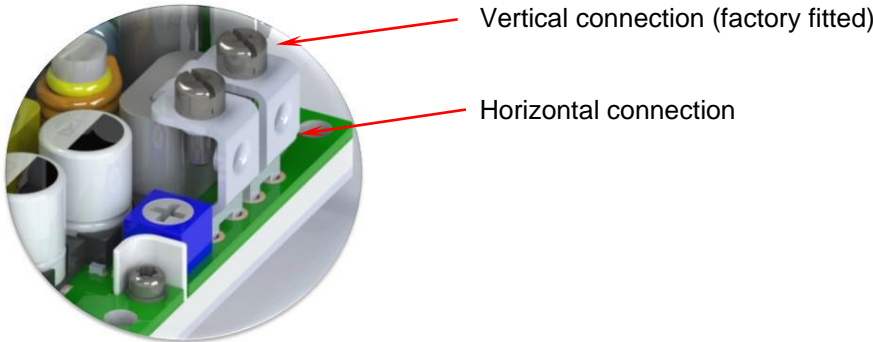

**Fan Supply J500**

The fan output (where specified) is provided via 2-way Header (ref J500) on the vertical daughter PCB. The header has a friction lock.

J500 – Fan Supply

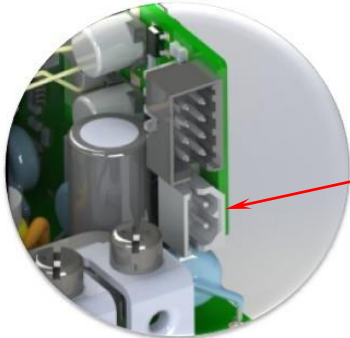

J500 pinout	
Pin 1	+V Fan
Pin 2	0V Fan

Refer datasheet outline drawing for Pin1 location  
 Mating Connector : Molex 50-37-5023 (Housing), Molex 08-70-1039 (Terminal)

## Standby output and signals J400

Standby output and signals (where specified) are provided via 8-way header (ref J400) on the vertical daughter PCB.

The header has a friction lock.

### J400 – Standby and signals

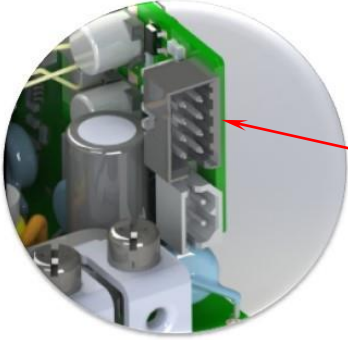

J400 pinout	
Pin 1	+V Standby (+5V)
Pin 2	0V Standby
Pin 3	AC FAIL Collector
Pin 4	DC OK Collector
Pin 5	AC FAIL Emitter
Pin 6	DC OK Emitter
Pin 7	Remote On/Off -
Pin 8	Remote On/Off +

Refer datasheet outline drawing for Pin1 location  
Mating Connector : Molex 51110-0851 (Housing), Molex 50394 (Terminal)

## OUTPUT PROTECTION

### No Load Operation

The power supply will operate with no load on the output with no damage, hazardous condition or reduction in performance.

Input power with CH1 inhibited and no load on standby and fan output is less than 0.5W

### Over current and Short Circuit Protection

Overloads and short circuits on any PSU output will cause no immediate damage to the power supply. Note the power supply is not designed to operate continuously in short circuit or overload condition and components may be thermally stressed and/or over temperature protection may trigger which will latch the PSU.

#### CH1 Output

An overload or short circuit of the CH1 Output will cause a hiccup state of CH1 - 'Off' for typically 1000 mS, then 'On' for typically 50 mS. The output will normally automatically restart when the short circuit or over current is removed.

At low AC input, a heavy overload may trigger a shorter off period cycle (typ 50mS). Prolonged operation in this condition with higher duty cycle for >20seconds may result in thermal shutdown.

Standby Output will remain in regulation for all conditions but the Fan output will follow CH1 output state (i.e hiccup or possibly latch-off due to thermal shutdown for heavy overload condition).

#### Fan Supply

An overload or short circuit of the fan output will cause ALL PSU outputs to enter a hiccup state. The outputs will automatically recover when the short circuit or over current is removed from the fan output.

#### Standby Output

An overload/short circuit of the Standby Output will cause the output to enter a constant current regulation state (or hiccup if thermal protection in the standby regulator triggers) and will attempt to restart until the short circuit or overload is removed.

If Standby Output is in Over current or Short Circuit Protection and there is no load on the Fan Output then CH1 Output will remain in regulation.

If Standby Output is in Over current or Short Circuit Protection and the Fan Output is fully loaded then all 3 outputs may or may not enter a hiccup state.

## **Over temperature protection**

There are thermal sensors on the PSU primary side and the secondary side circuits. Additionally, some components have internal over temperature protection built in (e.g standby regulator). Note the PSU is not designed to operate continuously in an over-temperature condition and service life could be shortened as a result.

Over temperature protection causes a PSU latch-off condition - there are two recovery methods:-

1. remove the ac supply for at least 60 seconds and then reapply,
2. remotely turn off the PSU using remote on/off signal (either disable or inhibit – option dependent) for at least 50 mS.

## **Over voltage protection**

### **CH1 Output**

An overvoltage on the CH1 Output will cause the CH1 and Fan Output to latch-off. There are two recovery methods from OVP:

1. remove the ac supply for at least 60 seconds and then reapply,
2. remotely turn off the PSU using the remote on/off signal (either disable or inhibit – option dependent) for at least 50 mS.

### **Fan Supply**

Fan supply voltage tracks the CH1 output voltage including during an over voltage condition. The fan supply itself does not have an independent over-voltage protection.

### **Standby Output**

There is a crowbar on the Standby output and an overvoltage condition will trigger the crowbar. The crowbar will create a short circuit on the Standby output. As a result the Standby output will follow the short circuit protection sequence described previously.

**SIGNALS**

All signals have functional isolation to the CH1 and Fan supply (max 200V<sub>DC</sub>) and to the Standby output (max 125V<sub>DC</sub>). All signals have functional isolation to each other (max 125V<sub>DC</sub>). There is a 10nF capacitor and a 2MOhm resistor between 0V Fan (J500-2) and 0V Standby (J400-2).

**Remote On/Off**

Remote On/Off signal can be factory configured as INHIBIT (specify J option) or ENABLE (specify G option). Remote On/Off is an isolated opto-coupler LED diode input. A minimum current of 1mA through the LED diode will inhibit or enable (option dependent) CH1 output and Fan Supply. LED current in the range 50uA~1mA should be avoided as this may cause un-intentional operation of the remote on/off function. Note that the Standby Output remains on regardless of the remote on/off state.

**Signal ratings – Remote On/Off**

Signal type	Uncommitted opto-coupler LED with 390R 1/8W series resistor
Min LED 'on' current	1mA
Max LED 'on' current	13mA
Max LED 'off' current	50µA

**Typical circuit – Remote On/Off**

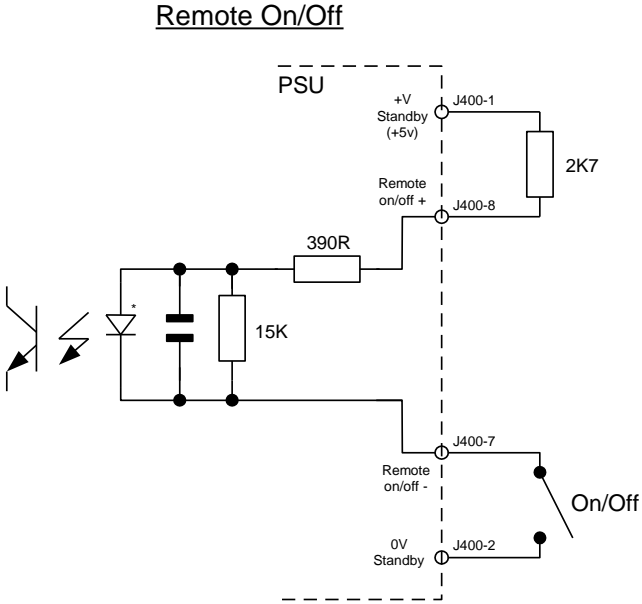

Switch	PSU Option	Function
Open	J - Inhibit	CH1 & Fan supply on
Closed	J - Inhibit	CH1 & Fan supply off
Open	G - Enable	CH1 & Fan supply off
Closed	G - Enable	CH1 & Fan supply on



**AC FAIL**

This signal provides a minimum warning time ( $T_{AC\_FAIL\_warning}$ ) before loss of CH1 output voltage. AC FAIL is an isolated opto-coupler transistor output. The opto-coupler transistor is 'closed' when the input AC is good. Note that the transistor is 'open' if PSU is inhibited (or not enabled) via the Remote on/off function. The AC\_FAIL signal may be triggered during input voltage dips or interruptions.

**Signal ratings – AC Fail**

Signal type	Uncommitted optocoupler transistor
Max transistor $V_{CE}$ voltage	30V
Max $V_{CE}$ saturation voltage	0.4V at max $I_C$
Max $I_C$ current	1mA
Max Leakage (dark) current	10 $\mu$ A

**Typical circuit – AC FAIL**

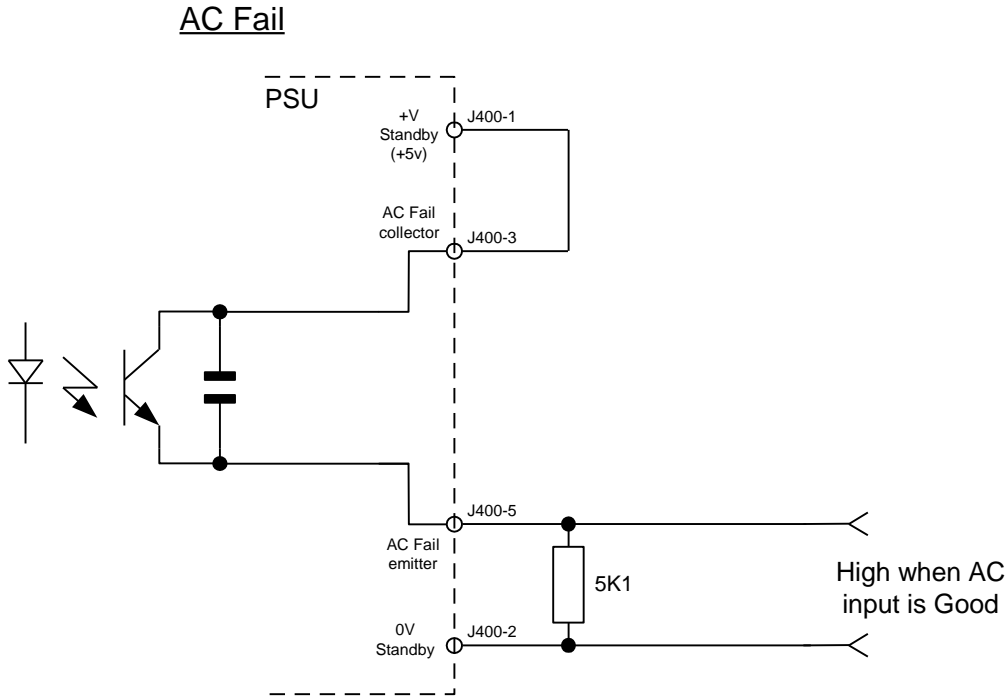

**DC OK**

DC OK is an isolated opto-coupler transistor output. The transistor is 'closed' when the CH1 Output is good. This signal provides an indication that CH1 Output is above DC\_OK<sub>th</sub> threshold.

**Signal ratings – DC OK**

Signal type	Uncommitted opto-coupler transistor
Max V <sub>CE</sub> voltage	30V
Max V <sub>CE</sub> saturation voltage	0.4V at max I <sub>c</sub>
Max I <sub>c</sub> current	1mA
Max Leakage (dark) current	10µA
DC OK <sub>th</sub> threshold	min 88%, max 95% of the CH1 Output set voltage, rising edge
DC OK hysteresis	5 % of the output voltage

**Typical circuit – DC OK**

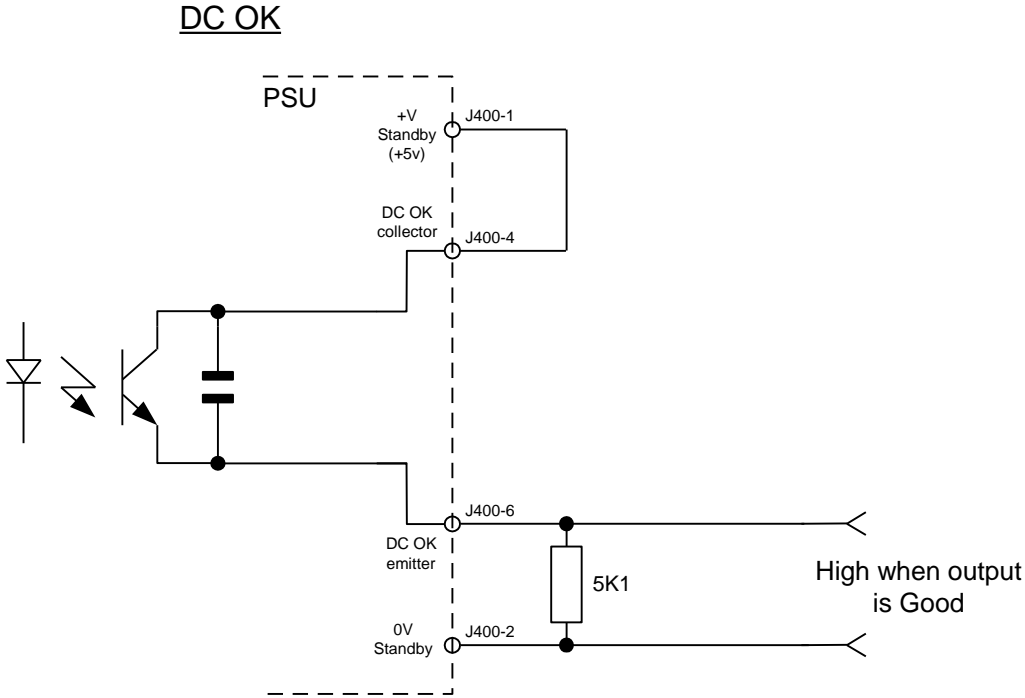

## OUTPUTS AND SIGNALS TIMING

### Output timing diagram

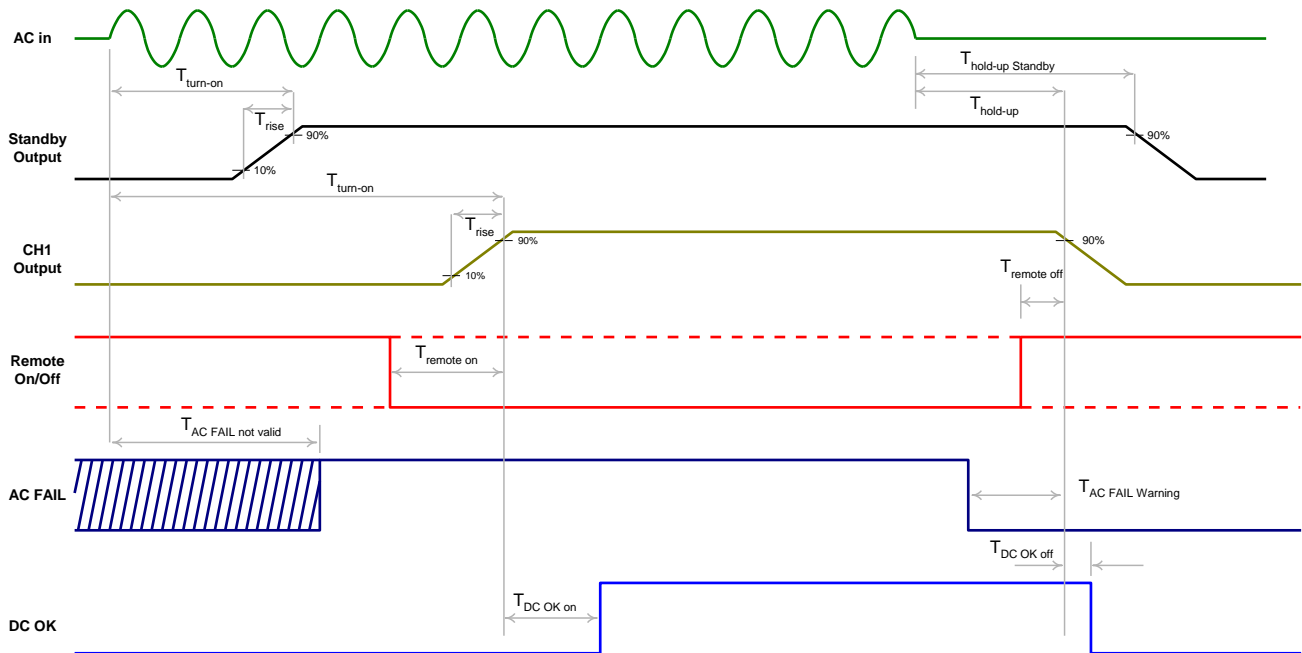

Parameter	Conditions	Units	min	max
$T_{turn-on}$		mS	-	1000
$T_{hold-up}^*$	CH1 100% load, Stand by and Fan output no-load	mS	14	-
	CH1 50% load, Stand by and Fan output no-load	mS	28	-
$T_{hold-up Standby}$	Standby 100%, CH1 and Fan any load	mS	300	-
$T_{remote on}$		mS	-	150
$T_{remote off}$	CH1 100% load	mS	-	50
$T_{rise}$		mS	-	50
$T_{AC FAIL not valid}$		mS	-	1000
$T_{AC FAIL warning}^*$	CH1 100% load	mS	5	-
	CH1 50% load	mS	10	-
$T_{DC OK on}^{**}$		mS	0	1
$T_{DC OK off}^{**}$		mS	-	0.5

\*The time at desired load can be calculated as  $T_{At\_desired\_Load} = T_{100\%} \times (Load_{100\%}/Load_{desired})$ . Valid when CH1 load is above 25W. Example for 40% load:  $T_{hold\_up\_at\_40\%} = 14ms \times (250W / 100W) = 35mS$ . Note that the desired load is total output power if Fan and Standby Output is loaded.

\*\*This is the time between  $DC\_OK_{th}$  threshold (not exactly 90% of  $V_{out}$  as shown) and  $DC\_OK$  signal status change. Refer  $DC\_OK$  signal section for threshold tolerance and hysteresis.

### EFFICIENCY

Following graph shows typical efficiency for 12V model at various load and line conditions.

CUS250M-12

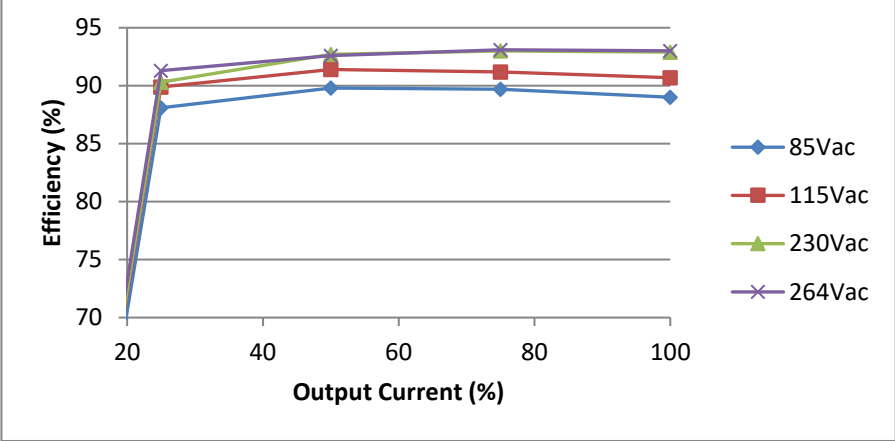

### STANDBY POWER (unit inhibited)

Following graph shows the typical power drawn from the AC line against load on the standby output when the CH1 is inhibited via the remote on/off signal (J & G options). The power varies slightly with AC input voltage.

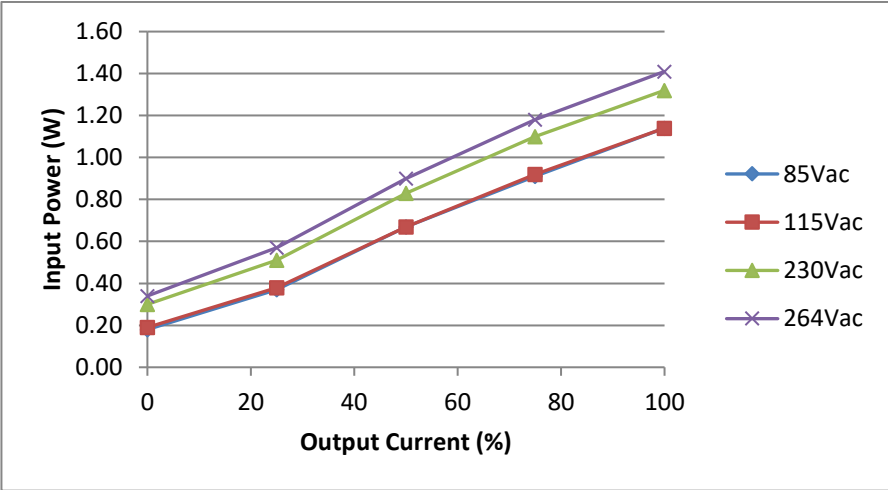

# LEAKAGE CURRENT CHARACTERISTICS

## Earth Leakage

Maximum earth leakage current of CLASS I equipment is shown in the following graphs for normal and single fault conditions.

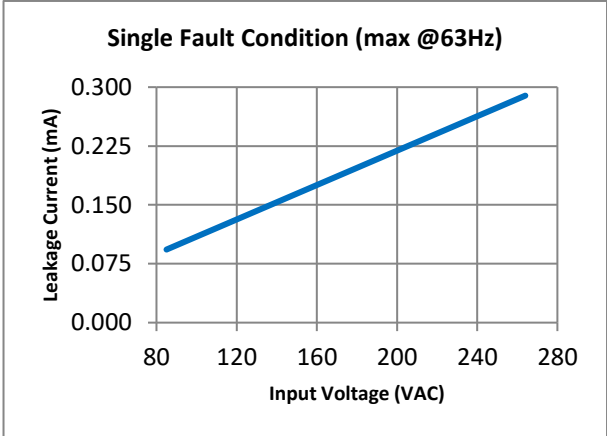
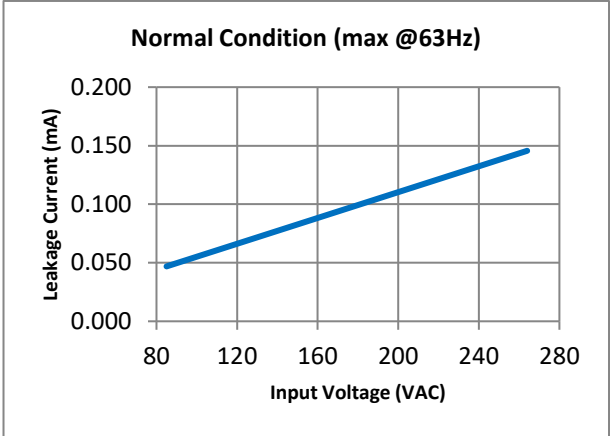

## Touch Current

Touch current measured on example unit is 5µA in CLASS I configuration and 50µA in CLASS II configuration.

**ELECTROLYTIC CAPACITOR LIFETIMES**

These curves help in determining capacitor life based on continuous (i.e. 24hrs/7days) operation. Actual temperature values should be measured in the end application as they depend upon the mounting orientation, ambient temperature and the type of cooling method involved.

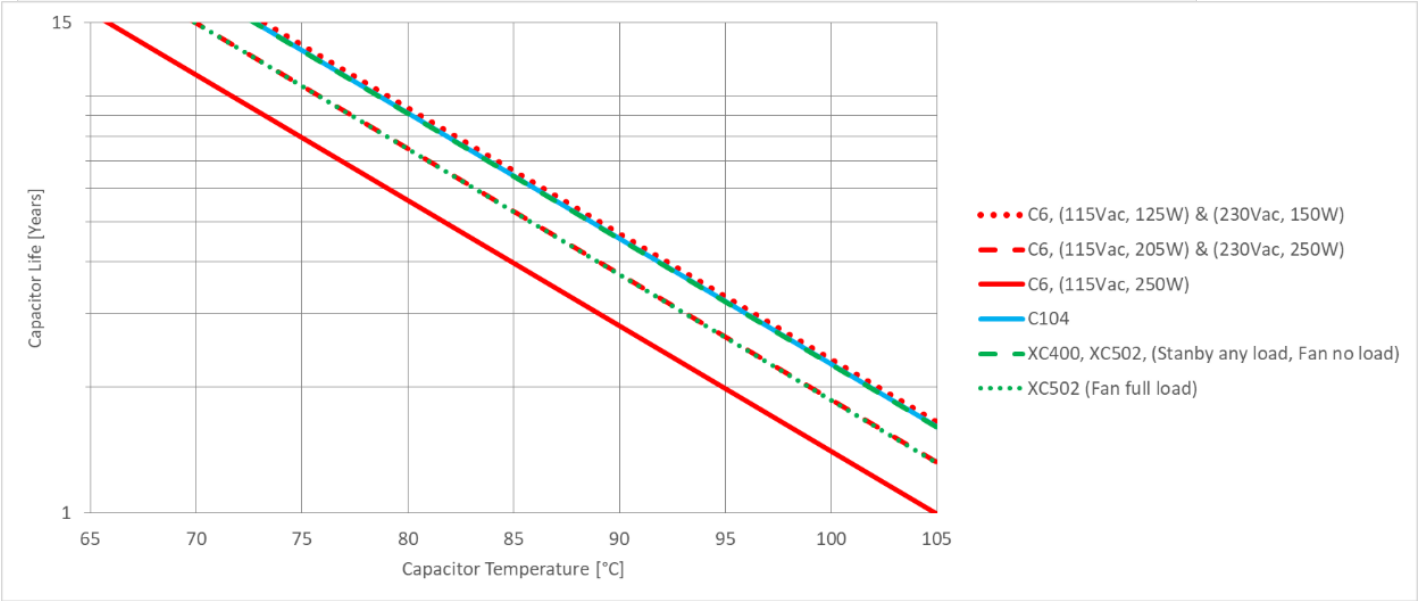
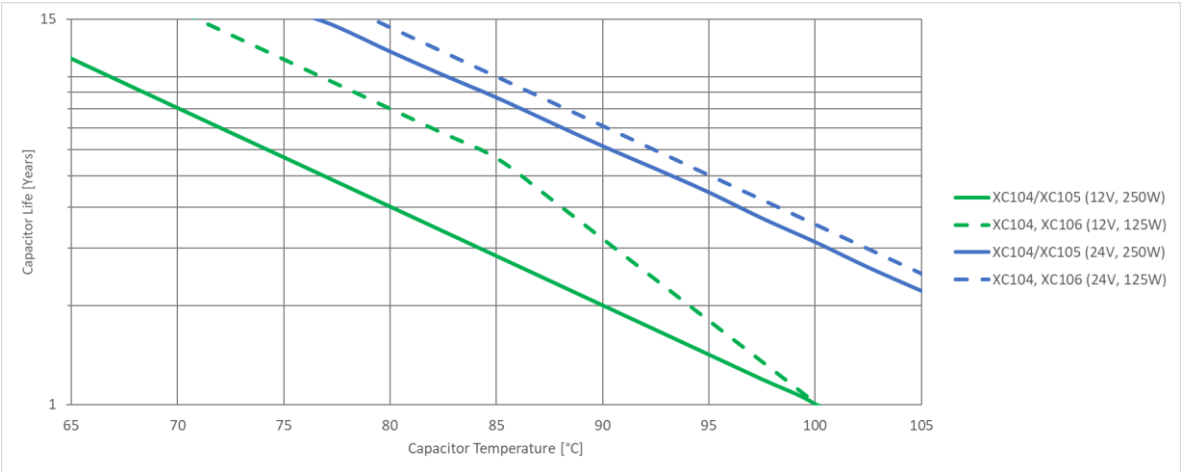

## COOLING

### ***Convection and Conduction Cooling***

The power supply may be mounted in any orientation except baseplate side upwards (where heat will not dissipate effectively from the PCB topside components).

Derating curves shown in the product datasheet are characterised with horizontal mounting, baseplate downward orientation and a 50mm clearance around the product.

Vertical orientation can however provide better performance with improved convection or conduction cooling and also increased electrolytic capacitor life.

Open frame units are generally best mounted either :-

- i) horizontal with baseplate vertical
- ii) vertical with output terminals lowest

The actual performance may however vary in end user application due to surrounding objects and convection airflow around the power supply.

Conduction cooling will generally lower the baseplate temperature which in turn will lower the temperature of PCB topside components and provide increased electrolytic capacitor life.

Approximately 45% to 70% of losses can be dissipated through the baseplate. The actual number varies with input or output conditions and cooling of top side components in actual application.

Conduction cooling derating curves shown in the product datasheet were produced with PSU mounted centrally on a 300mm x 300mm x 1mm aluminium plate with natural finish. No additional airflow was provided for top side components and no thermal paste was used for this measurement.

### ***Forced air Cooling***

For airflow cooling it is recommended to select the U channel option or attach the unit to a metal chassis to increase the heat transfer from baseplate to the flow of air.

The top mounted fan on /F models has a nominal airflow of 8CFM.

**PEAK POWER CAPABILITY**

Model variants that have derated continuous power are still capable of providing 250W for short periods of time. The duration of peak power is a function of continuous power. The temperature of inrush limiter TH1 (PCB topside adjacent to AC input connector) is one of the main limiting components. This component has small mass and correspondingly short thermal time constant. The body of TH1 should not be allowed to exceed 153DegC. Refer also to the product instruction manual 'Cooling for Unit' section for other PSU components temperatures that should be verified. The graphs below provide some guidance of peak power durations that may be achieved.

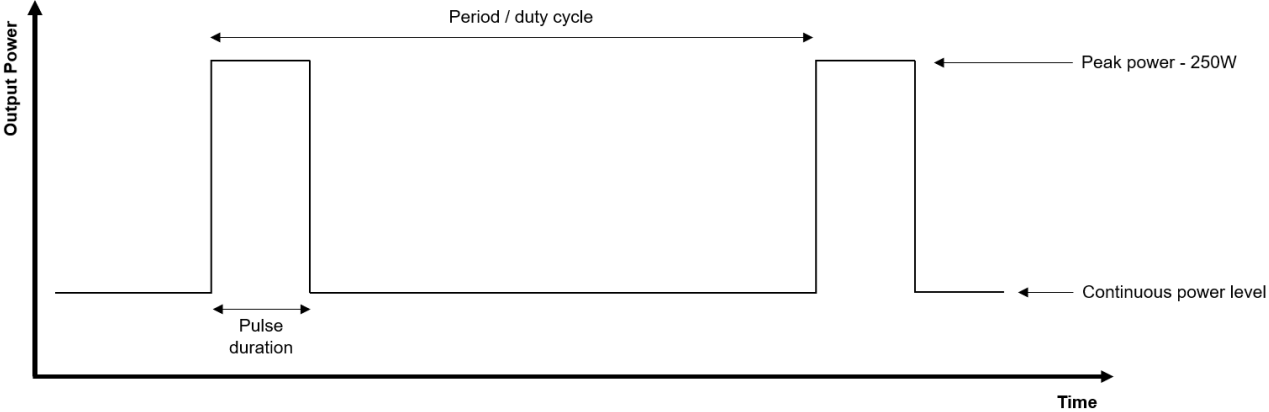

Open frame unit, convection cooled

U chassis variant on 300mmx300mm Al Plate

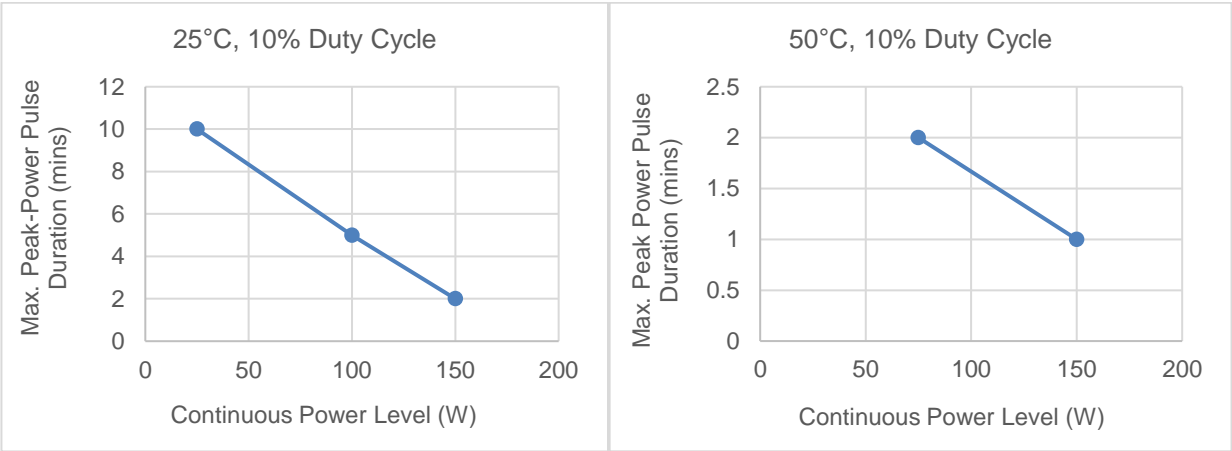



## CAPACITIVE LOAD

The specifications for maximum external capacitance connected to the output are listed below. These values are given for nominal output voltage. Where the CH1 output is adjusted up, the capacitive load should be proportionately reduced.

Model	Capacitive Load Rating		
	CH1	Standby	Fan
12V	1000 $\mu$ F/Amp	100 $\mu$ F	100 $\mu$ F
24V	220 $\mu$ F/Amp		

## RELIABILITY

Calculated according to Telcordia SR332 Issue 4, Method I-D (Black Box), Ground Fixed Controlled

The failure rates in Failures In Time (FITs) is given for the PSU assembly at a confidence level of 90% in the table below at 20°C; 30°C; 40°C; 50°C; 60°C; and 70°C.

Telcordia SR332 Issue 4		
Ambient (°C)	FITs	MTBF (hrs)
20	196	5102041
30	278	3597122
40	405	2469136
50	589	1697793
60	858	1165501
70	1250	800000

## **ELECTROMAGNETIC COMPATIBILITY**

### ***Installation for Optimum EMC Performance***

#### ***Mounting***

All equipment should, ideally, be mounted inside an earthed, shielded metal box or an earthed metal plate to mount the power supply and load. All four mounting holes (one in each corner) of the CUS250M should be utilised for best electrical and mechanical performance.

Keep any cables or load away from TX100 (main transformer).

The CUS250M can be operated as a Class II power supply (without a ground connection).

The radiated and conducted emissions of CUS250M were tested as 'standalone' unit. The measurements shown in following pages are representative of 'standalone' operation.

An EMC compliance report is available on request – contact Technical Sales for details.

#### ***Cables***

All cables (both AC input and DC output) should be run as close as possible to the earthed metal box/plane. All output cables should be routed as far away from the input cables as possible. If the input and output cables must run close to each other, it is recommended to screen one of them (or ideally both). The positive and negative output cables should be twisted together. All cable run loops should be kept as small as possible (this should be implemented in the system PCB design as well).

#### ***Earth Star Point***

Where the AC supply enters the equipment, this should be taken to a 'star point' chassis mounted earth point as close as possible to the mains inlet. All other earth points should be taken back to this point only.

#### ***Switching Frequency***

All 3 converters (PFC, DCDC, Flyback) in the CUS250M have a variable switching frequency within range from 25 kHz to 300 kHz (burst mode excluded). The actual frequencies depend upon the input voltage, output voltage and output load.

Conducted Emissions

Conducted Emissions – CUS250M-12/J, 240Vac, Class I, Full Load, EN55011

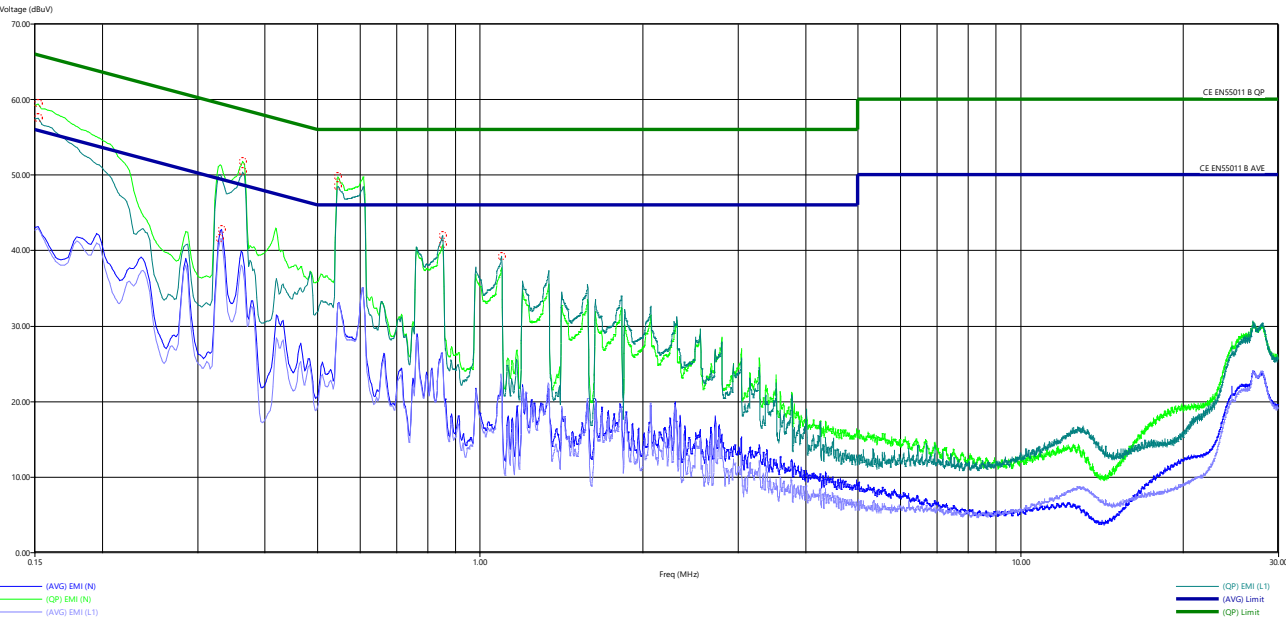

Conducted Emissions – CUS250M-12/J, 240Vac, Class II, Full Load, EN55011

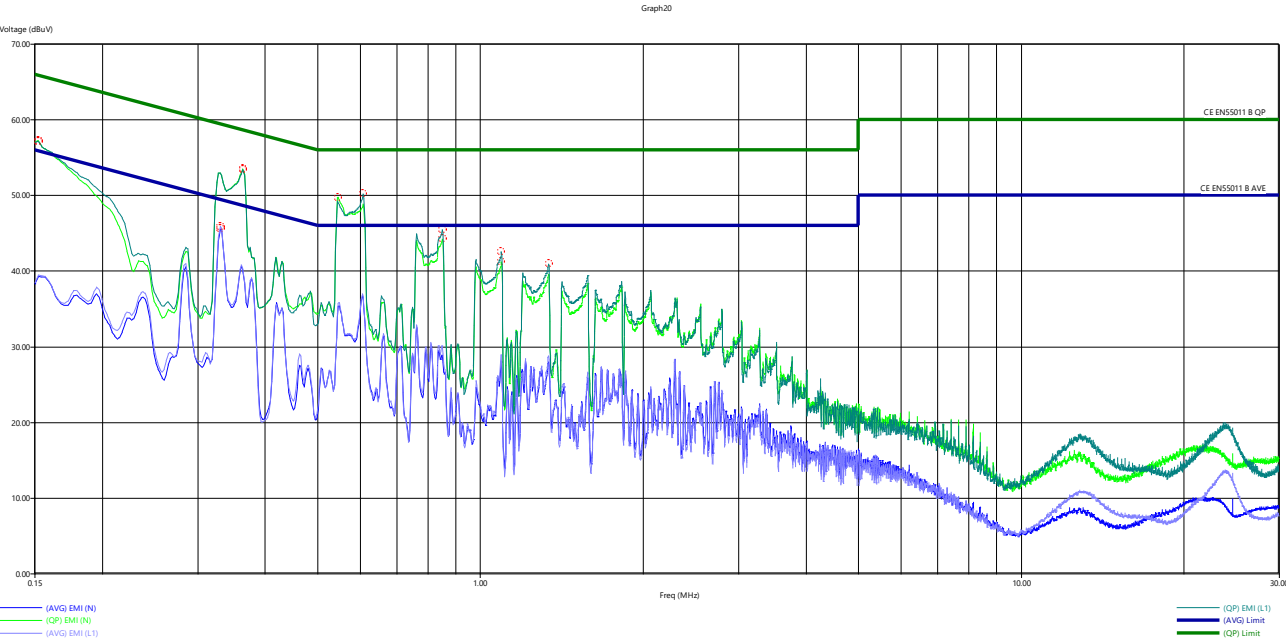

Radiated Emissions

Radiated Emissions – CUS250M-12/J, 240Vac, Class I, Full Load, EN55011

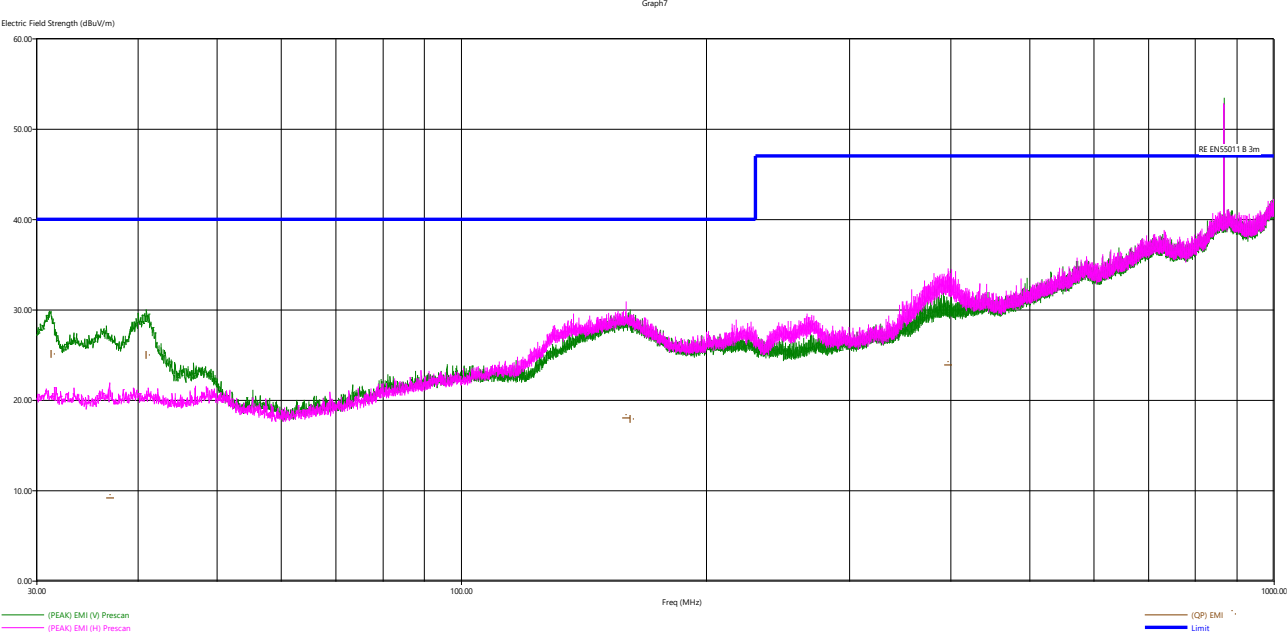

Radiated Emissions – CUS250M-12/J, 240Vac, Class II, Full Load, EN55011

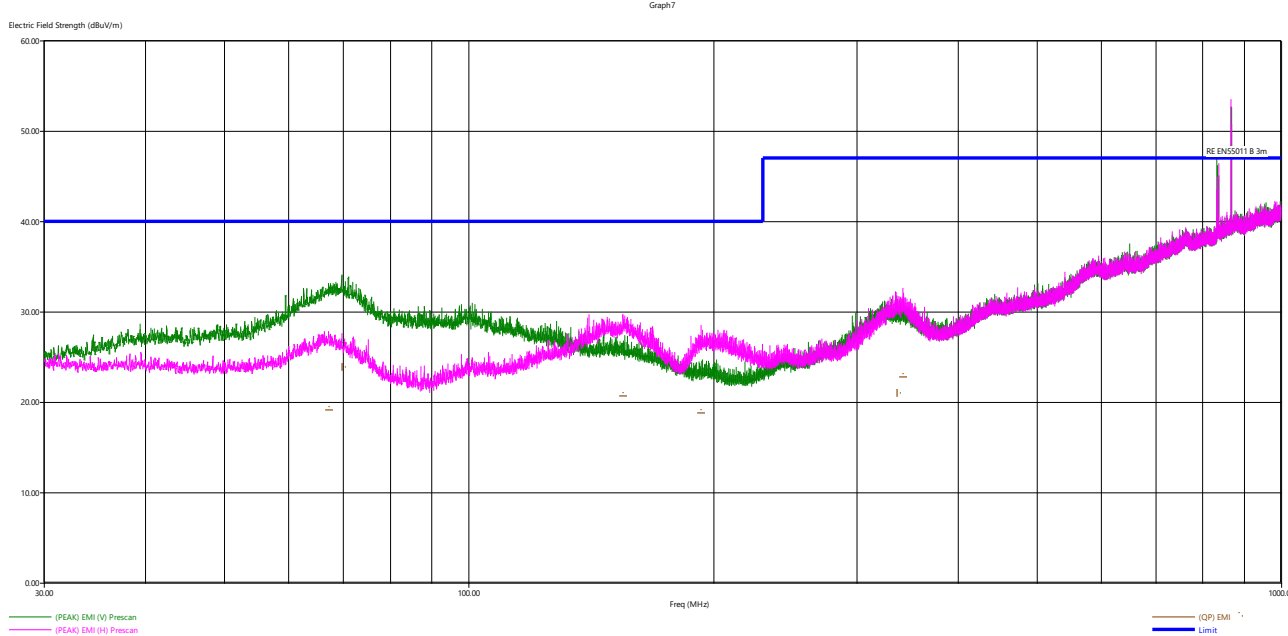

**MECHANICAL**

**Weight**

The weight for all mechanical options is specified in the product datasheet. J, G, C, M and E option has negligible impact on product weight.

**Mounting**

See datasheet for outline drawing. A Thermal Interface Material is recommended between baseplate / U chassis and system chassis. All options are designed for M3 screws.

**Standard and C option**

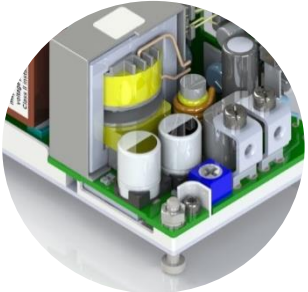
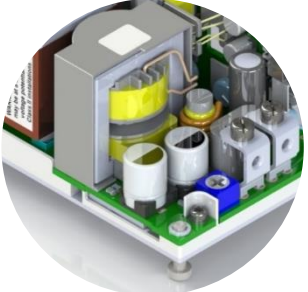
Standard model		C option
		
From Top	From Bottom	From Bottom

**Chassis options**

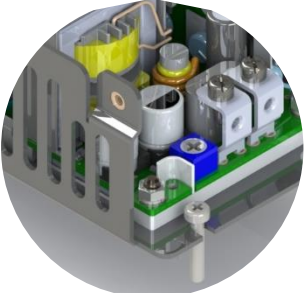
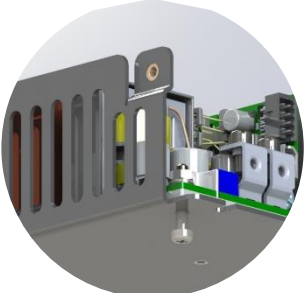
A, F and U option	
	
From Top Note that using the slots for fixing from bottom with nut/washer arrangement at the topside may violate creepage and clearance distance requirements from earth to PSU output.	From Bottom Into underside of PCB mounting fixings