

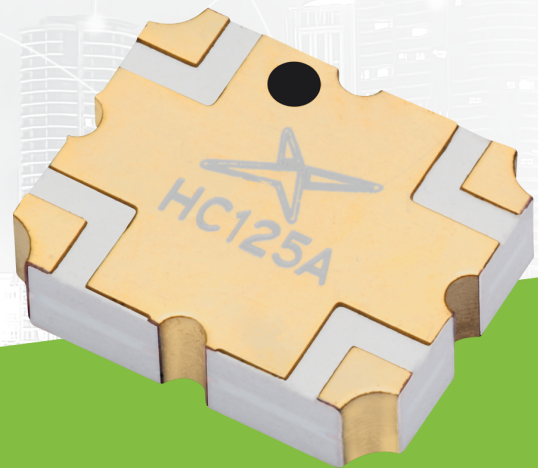

TAOGLAS®



Datasheet

High Performance Multiband GNSS Hybrid Coupler

Part No:
HC125.A

Description:

Low Profile, High Performance Multiband GNSS Hybrid Coupler

Features:

Frequencies Covered:

- 1150-1630 MHz

Low Insertion Loss

Tight amplitude balance and high isolation

Low VSWR

Au surface plated to prevent oxidation

Supplied on Tape & Reel

Dimensions: 6.35 x 5.08 x 1.5mm

RoHS & Reach Compliant

1. Introduction	3
2. Specifications	4
3. Typical Performance	6
4. Pin Configuration	7
5. Performance @ 25°C	8
6. Mechanical Drawing	10
7. PCB Layout	11
8. Solder Reflow Diagram	12
9. Packaging	13
<hr/>	
Changelog	24

Taoglas makes no warranties based on the accuracy or completeness of the contents of this document and reserves the right to make changes to specifications and product descriptions at any time without notice. Taoglas reserves all rights to this document and the information contained herein. Reproduction, use or disclosure to third parties without express permission is strictly prohibited.



1. Introduction



The Taoglas HC125.A is a low profile, high performance, 3dB hybrid coupler in an easy to integrate surface mount package. It is designed for multi feed GNSS applications. The HC125.A is particularly used for applications where balanced power and low noise amplifiers are required. It has low insertion loss and tight amplitude and can be used in power applications up to 30 Watts. It has been engineered to cover the full GNSS bandwidth of 1150 – 1630MHz.

The HC125.A has been subjected to rigorous qualification testing and it is manufactured using materials with coefficients of thermal expansion (CTE) compatible with common substrates such as FR4, G-10, RF-35, RO4350 and polyimide.

The HC125.A is the perfect companion to ensure successful integration of multi feed high performance, high precision GNSS patches from Taoglas such as the full band GPDF5012.A or the dual L1 feed GPDF254.A. Integration details are included in specific product datasheets but for further information regarding the HC125.A or it's integration with any of our antennas, please contact your regional Taoglas customer support team.

2. Specifications

GNSS Frequency Bands Covered							
GPS	L1	L2	L5				
	■	■	■				
GLONASS	G1	G2	G3				
	■	■	■				
Galileo	E1	E5a	E5b	E6			
	■	■	■	■			
BeiDou	B1	B2a	B2b	B3			
	■	■	■	■			
QZSS (Regional)	L1	L2C	L5	L6			
	■	■	■	■			
IRNSS (Regional)	L5						
	■						
SBAS	L1/E1/B1	L5/B2a/E5a	G1	G2	G3		
	■	■	■	■	■		

*SBAS systems: WASS(L1/L5), EGNOS(E1/E5a), SDCM(G1/G2/G3), SNAS(B1,B2a), GAGAN(L1/L5), QZSS(L1/L5), KAZZ(L1/L5).

GNSS Bands and Constellations

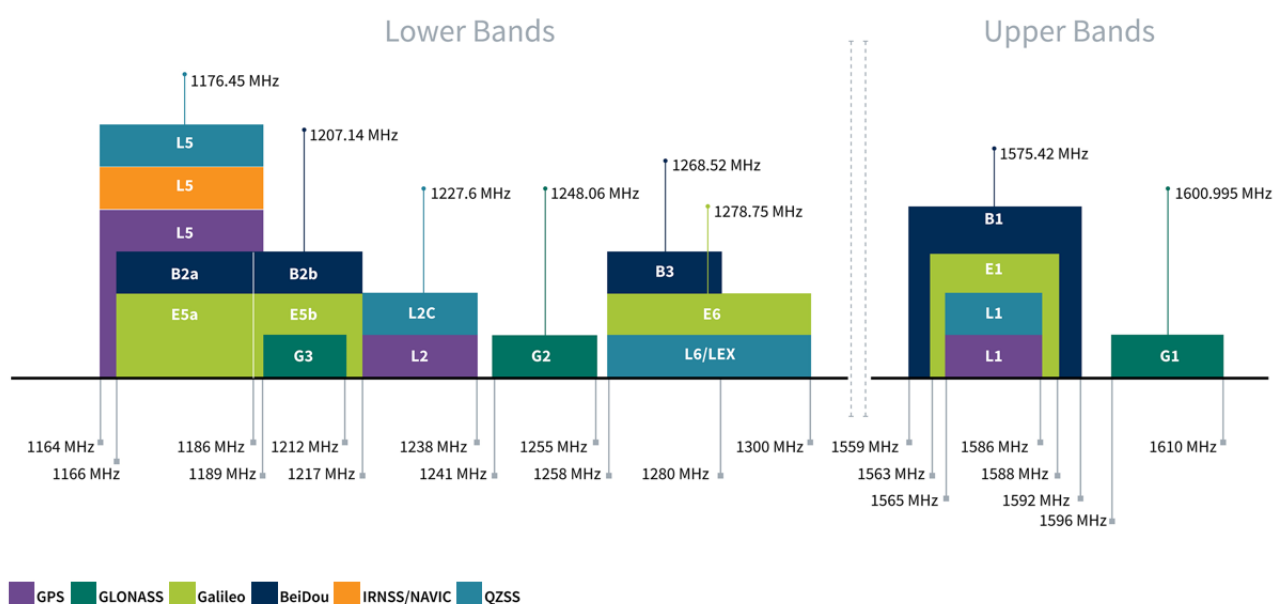

Electrical Specifications	
Parameter	Value
Frequency	1150 – 1630MHz
Isolation	22dB Min
Insertion Loss	0.3 dB Max
VSWR	1.2
Amplitude Balance	+/- 0.35 dB Max
Phase Balance	90 Degrees
Power	30 CW Watts Avg.

Note: All of the above data is based on HCD125.A evaluation board.

Mechanical	
Dimensions	6.35 x 5.08 x 1.5mm
Weight	1 g

Environmental	
Temperature Range	-55°C to +85°C
RoHS & REACH Compliant	Yes

3. Typical Performance Data (@25°C)

Frequency (MHz)	Coupling (dB)	Transmission (dB)	Insertion Loss (dB)	Isolation (dB)	Amplitude Balance (dB)	Phase (degree)	Return Loss(dB)			
							S11	S22	S33	S44
1150	-3.27	-3.06	-0.15	-33.46	-0.21	91.90	-32.97	-29.08	-35.22	-30.96
1174	-3.23	-3.11	-0.16	-34.97	-0.12	92.06	-33.44	-29.33	-34.10	-32.00
1198	-3.19	-3.12	-0.14	-36.64	-0.07	92.03	-34.09	-29.71	-33.10	-33.40
1222	-3.18	-3.16	-0.16	-38.85	-0.02	92.09	-34.80	-30.32	-31.94	-34.84
1246	-3.14	-3.19	-0.15	-41.64	0.05	92.18	-35.31	-31.26	-30.72	-36.39
1270	-3.15	-3.23	-0.18	-44.79	0.08	92.25	-35.47	-32.31	-29.61	-38.58
1294	-3.14	-3.26	-0.19	-47.45	0.12	92.42	-35.29	-33.51	-28.71	-41.10
1318	-3.11	-3.25	-0.17	-46.04	0.14	92.46	-34.85	-34.69	-27.90	-43.59
1342	-3.11	-3.29	-0.19	-42.59	0.18	92.50	-34.47	-35.35	-27.28	-43.20
1366	-3.10	-3.28	-0.18	-39.71	0.18	92.43	-34.16	-35.35	-26.71	-40.66
1390	-3.10	-3.30	-0.19	-37.53	0.20	92.50	-33.91	-34.81	-26.20	-37.79
1414	-3.11	-3.32	-0.20	-35.73	0.21	92.58	-33.55	-34.00	-25.62	-35.65
1438	-3.11	-3.29	-0.19	-34.27	0.18	92.66	-33.01	-33.13	-25.07	-33.77
1462	-3.12	-3.30	-0.20	-32.98	0.18	92.71	-32.29	-32.39	-24.47	-32.10
1486	-3.13	-3.29	-0.20	-31.87	0.16	92.78	-31.60	-31.85	-23.93	-30.71
1510	-3.15	-3.30	-0.21	-30.92	0.15	92.84	-31.00	-31.52	-23.51	-29.41
1534	-3.18	-3.29	-0.22	-30.06	0.11	92.96	-30.51	-31.38	-23.18	-28.35
1558	-3.21	-3.28	-0.23	-29.29	0.07	92.89	-30.02	-31.25	-22.88	-27.47
1582	-3.25	-3.27	-0.25	-28.57	0.02	92.97	-29.36	-30.78	-22.63	-26.65
1606	-3.33	-3.27	-0.29	-27.95	-0.06	92.98	-28.73	-29.84	-22.36	-25.93
1630	-3.33	-3.20	-0.25	-27.34	-0.13	92.99	-28.00	-28.67	-21.99	-25.27

4. Pin Configuration

The HC125.A has an orientation marker to denote Pin 1. Once port one has been identified the other ports are known automatically. Please see the chart below for clarification:

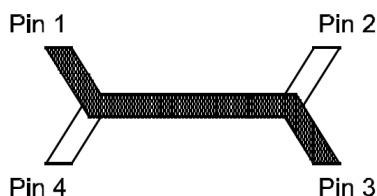

Configuration	Pin 1	Pin 2	Pin 3	Pin 4
Splitter	Input	Isolated	$-3\text{dB } \angle\theta - 90$	$-3\text{dB } \angle\theta$
Splitter	Isolated	Input	$-3\text{dB } \angle\theta$	$-3\text{dB } \angle\theta - 90$
Splitter	$-3\text{dB } \angle\theta - 90$	$-3\text{dB } \angle\theta$	Input	Isolated
Splitter	$-3\text{dB } \angle\theta$	$-3\text{dB } \angle\theta - 90$	Isolated	Input
*Combiner	$A \angle\theta - 90$	$A \angle\theta$	Isolated	Output
*Combiner	$A \angle\theta$	$A \angle\theta - 90$	Output	Isolated
*Combiner	Isolated	Output	$A \angle\theta - 90$	$A \angle\theta$
*Combiner	Output	Isolated	$A \angle\theta$	$A \angle\theta - 90$

Note:

The "A" is the amplitude of the applied signals. When two quadrature signals with equal amplitudes are applied to the coupler as described in the table, they will combine at the output port. If the amplitudes are not equal, some of the applied energy will be directed to the isolated port.

5. Typical Performance (-55°C, 25°C, 95°C, 125°C: 1150-1630 MHz)

Return Loss (Port 1)

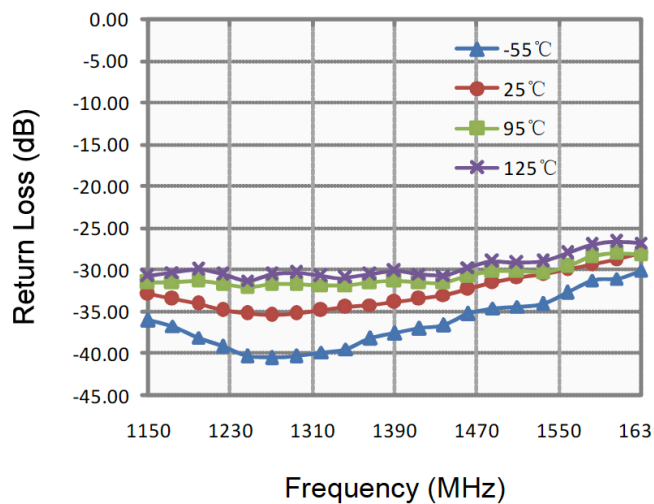

Return Loss (Port 2)

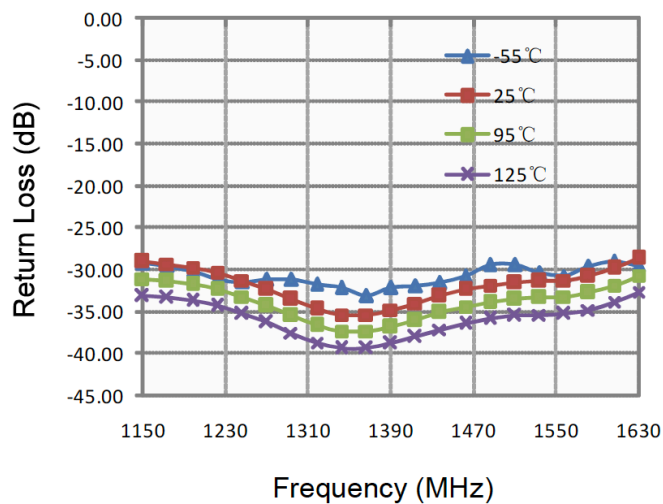

Return Loss (Port 3)

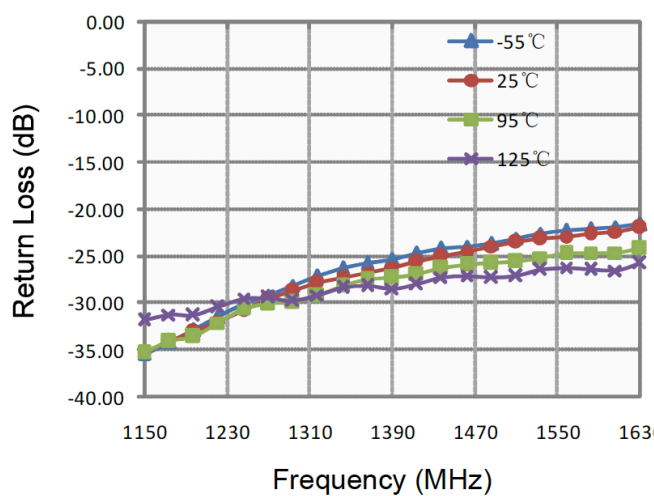

Return Loss (Port 4)

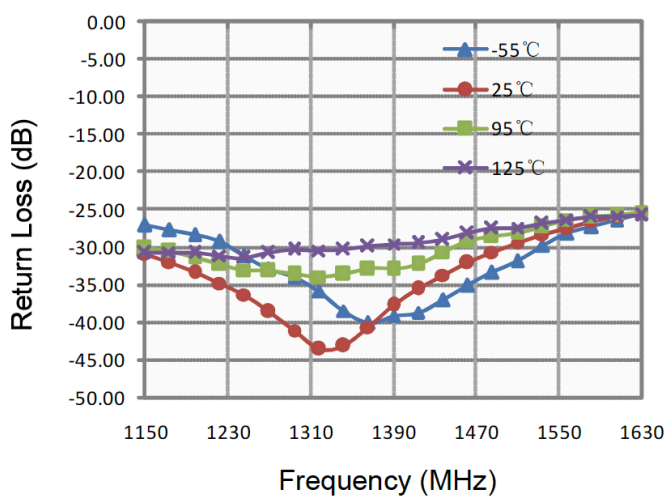

Coupling & Transmission (Port 1 feeding)

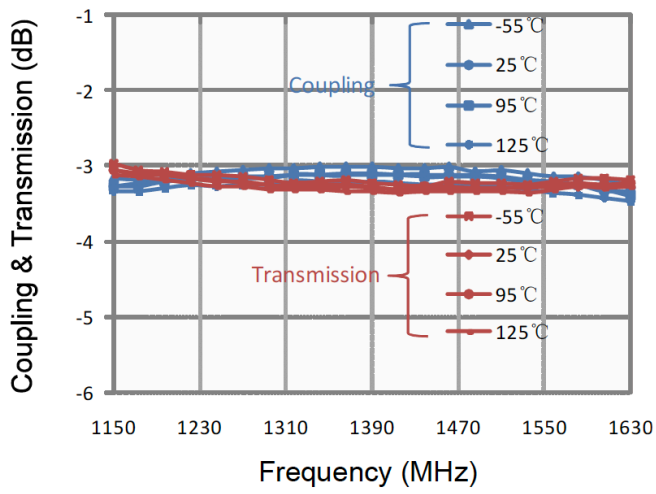

Insertion Loss (Port 1 feeding)

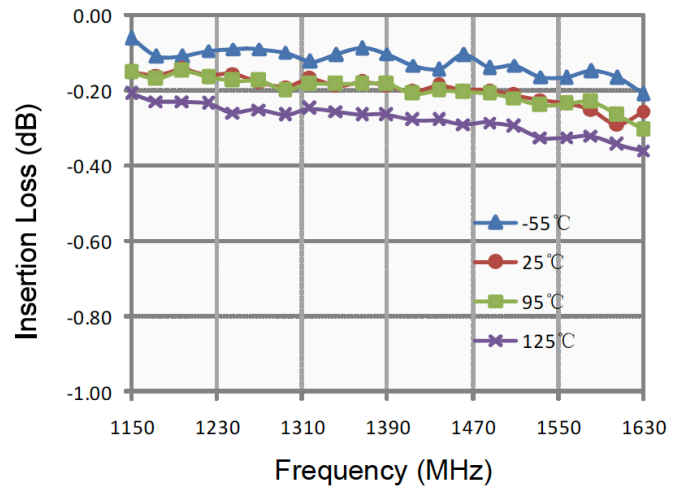

Phase (Port 1 feeding)

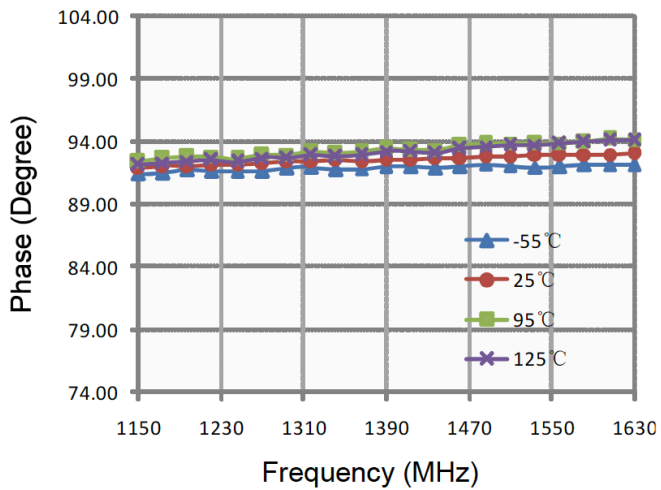

Isolation (Port 1 feeding)

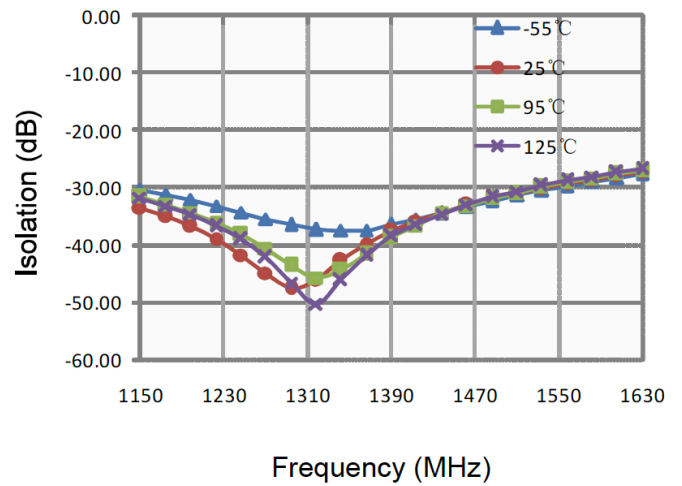

6. Mechanical Drawing (Units: mm)

ISO NO.: EDW-20-8-0883



STATE: Release

NOTES: 1.All dimension show in millimeters.
2.RoHS Compliant in accordance with EU Directive(2011/65/EU)
3.Dimension tolerance:±0.20

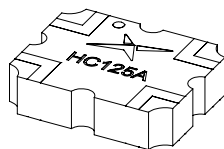
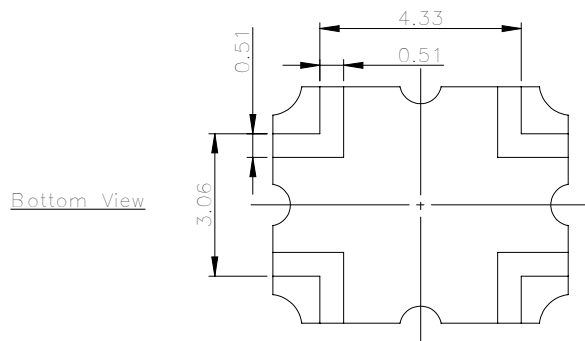
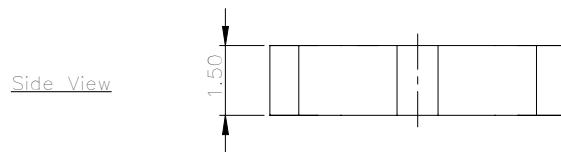
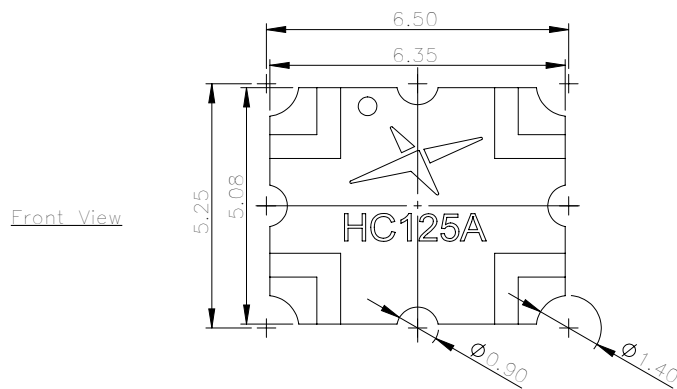
REV	ZONE	DESCRIPTION	ENG	APPROVED	DATE
D01	All	Initial design	Aron Yan	Clark	2020/10/08



3D View

APPROVED BY: Clark	 TAOGLAS TW Design Centre <small>This drawing and its inherent design concepts are property of Taoglas. Not to be copied or given to third parties without the written consent of Taoglas.</small>		
CHECK BY: Aaron			
DRAWN BY: Aron Yan	TITLE: Low Profile, High-performance 3dB SMD Hybrid Coupler		
DATE: 2020/10/8	PART NO. :		
UNLESS OTHERWISE SPECIFIED: TOLERANCES ON: M:±0.5 F:±0.3 H:±0.2 X:±0.1 Y:±0.05	UNIT: mm SCALE: 8:1 PAGES: 1/1 REV: D01		
THIRD ANGLE PROJECTION			

7. Recommended PCB Layout

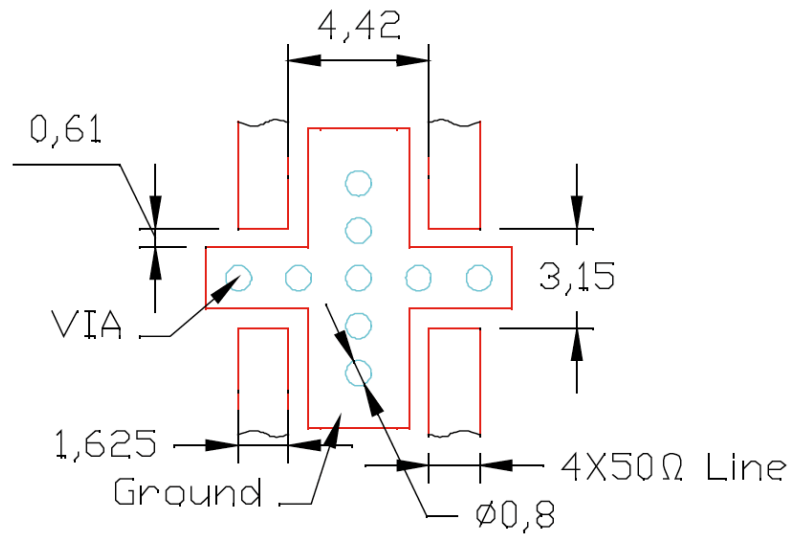

Notes:

1. 50Ω line width is shown above designing from RO4350B dielectric thickness 0.762mm; copper 1 OZ
2. Bottom side of the PCB is continuous ground plane.
3. All dimensions shown in mm.

8. Reflow Profile

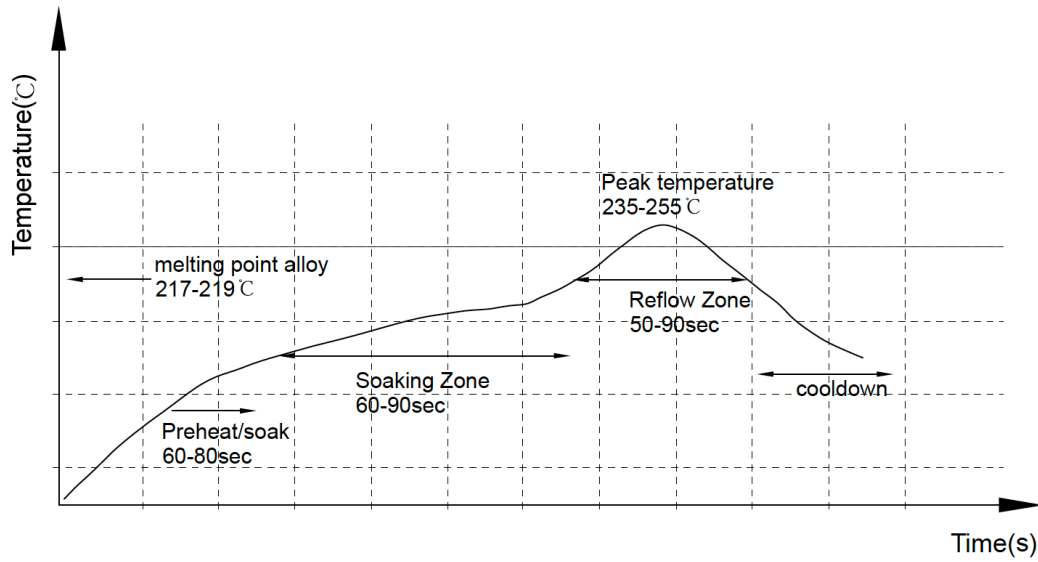

9. Packaging

1,000 pcs HC125.A per Reel
 Reel Dimensions: $\varnothing 177 \times 20.1$ mm
 Weight: TBD

- A.10 Sprocket hole pitch cumulative tolerance is 0.2mm.
- B. Carrier camber shall be not more than 1mm per 100mm through a length of 250mm.
- C. All dimensions meet EIA-418-B requirements
- D. A0 & B0 measured as indicated.
- E. K0 measured from a place on the inside bottom of the pocket to top surface of carrier.
- F. Material: PE 100
- G. Thickness: 0.30 ± 0.05 mm
- H. 1000 units (maximum) / T&R

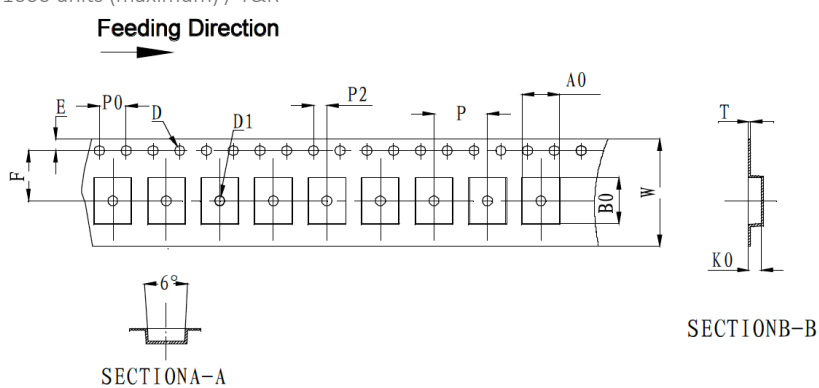

Symbol	Dimensions	
	(mm)	(inch)
W	16.5 ± 0.4	0.65
A	177 ± 0.5	7.0
N	63 ± 0.3	2.48
T	1.8 ± 0.2	0.071
E	2.1 ± 0.3	0.083
F	10.75 ± 0.3	0.423
D	$13.5 + 0.5 / - 0.2$	0.531

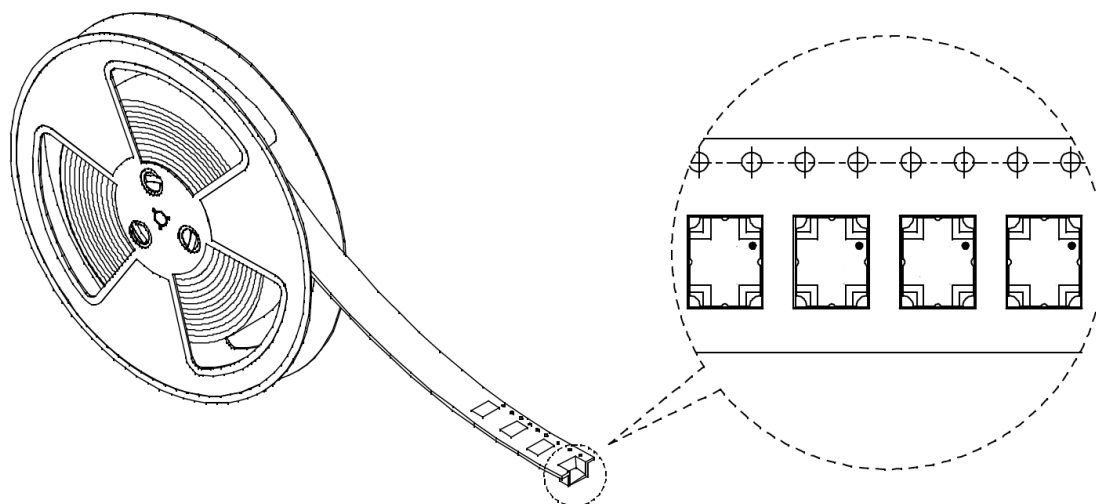

Changelog for the datasheet

SPE-20-8-103 – HC125.A

Revision: A (Original First Release)

Date:	2020-10-28
Notes:	Initial Release
Author:	David Connolly

Previous Revisions



TAOGLAS®

