

ZA10 maratone+

PR70
Hearing Aid Battery

Technical Data Sheet

Specifications

Chemical system	Zinc / Air
Nominal Voltage	1,4 V
Typical Capacity	100 mAh
Self Discharge	Less than 5% per year at 20 °C with label applied
Weight	~0,3g

These batteries need air when they are used. Battery compartment must allow free access of air
A period of at least 10 min shall elapse between activation and commencement of electrical measurement

Dimensions

(according IEC 60086-2)

Diameter	5.8 mm (0,228")
Height	3.6 mm (0,142")

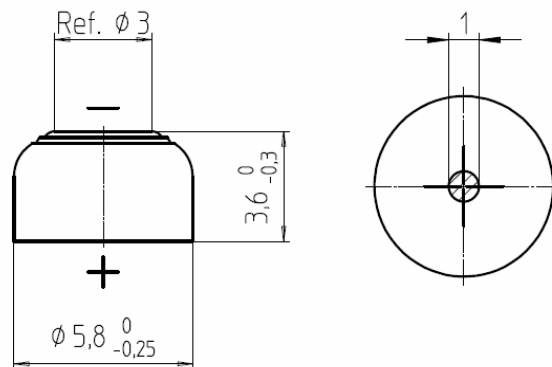

Air-intake hole placement

Discharge Curve

Standard discharge Load 2700 ohm 12 hours per day at 20 °C, 50%rh according IEC60086-2

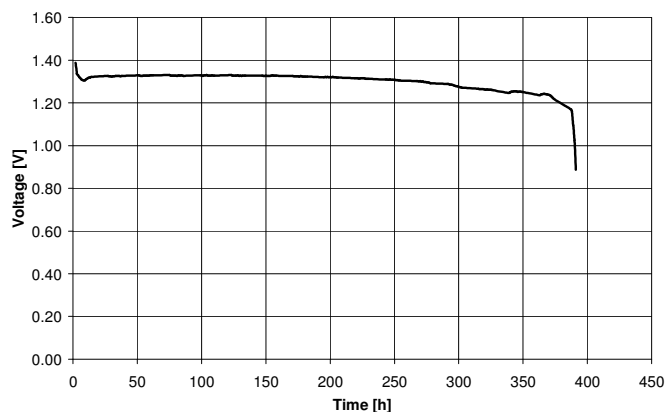

High Power Load
1 mA current, 5 mA pulsed for 100 ms every 2 hours

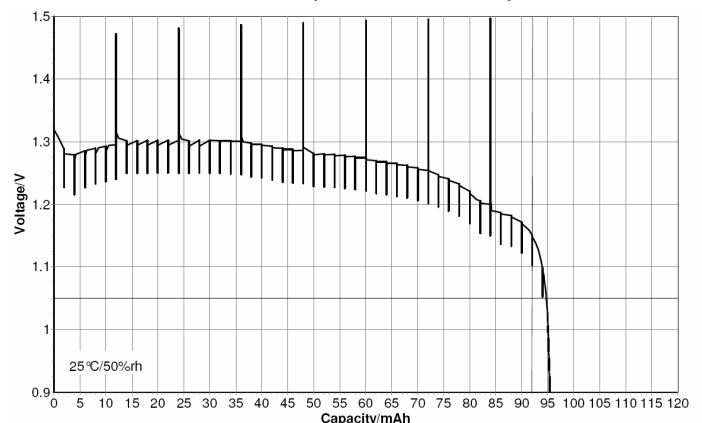

Information and contents in this data sheet are for reference purpose only. They do not constitute any warranty or representation and are subject to change without notice. For most current information and further details, please contact your Renata representative.

Rev. ZA10 Maratone+ / Rev. 3 / January 2009

A COMPANY OF THE **SWATCH GROUP**