

Amphenol PCD

Engineering Change Request		ECR Number	R6652W	
Initiator:	Celine	Date:	2022.11.11	
Part number description				
Item	K3 Code material part numbers	Drawing/ Doc Number	Version of current related document	New Version
1	C270003607	C-C270003607	3	4
2	C2700036071	C-C2700036071	2	3
3	C2700036072	C-C2700036072	3	4
4	HVSL630062XXXXXX	C-HVSL630062XXXXXX		N/A
5	HVSL600061XXXXXX	C-HVSL600061XXXXXX		N/A
6	HVSL280063XXXXXX	C-HVSL280063XXXXXX		N/A
Reason of change:				
<input type="checkbox"/> Customer requirement (list the feasibility analysis of customer specification: _____)				
<input type="checkbox"/> Supplier request (list the PCR number: _____)				
<input checked="" type="checkbox"/> internal improvement <input type="checkbox"/> corrective <input type="checkbox"/> other				
Please describe here in detail:				
HVSL630, HVSL600, HVSL280 plug's wire sealing, there aren't any P/N and cavity info on product surface. Now, APCD add P/N and cavity inform on them. It's better to clarify the difference quickly by visual.				
Change level and impact assessment (Please tick in the appropriate position)				
Change level	Change content	Whether to notify the customer		
Level 1	<input type="checkbox"/> Operator change	It is not necessary to notify the customer for approval		
	<input type="checkbox"/> Correct the clerical errors of the drawing, BOM, etc., and this change will not affect the production process			
Level 2	<input type="checkbox"/> Change of Main production equipment or tools/Jigs	<input checked="" type="checkbox"/> Customers should be notified for approval <input type="checkbox"/> It is not necessary to notify the customer for approval, the reasons are as follows:		
	<input type="checkbox"/> Change of main measuring equipment or tools/Jigs			
	<input type="checkbox"/> Appearance changes that do not affect product functions			
	<input type="checkbox"/> Changes in production process or processing technology			
	<input type="checkbox"/> Product structure or specification changes that have not been transferred to mass production			
Level 3	<input checked="" type="checkbox"/> Product structure or specification changes that have been transferred to mass production	<input checked="" type="checkbox"/> Customers should be notified for approval		
	<input type="checkbox"/> Supplier's production process change or supplier's production site change or addition or replacement of suppliers			
	<input type="checkbox"/> Change of production site			
	<input type="checkbox"/> Product material changes			

Amphenol PCD

<input type="checkbox"/> Change of packaging method	
<input type="checkbox"/> Changes proposed by the customer	

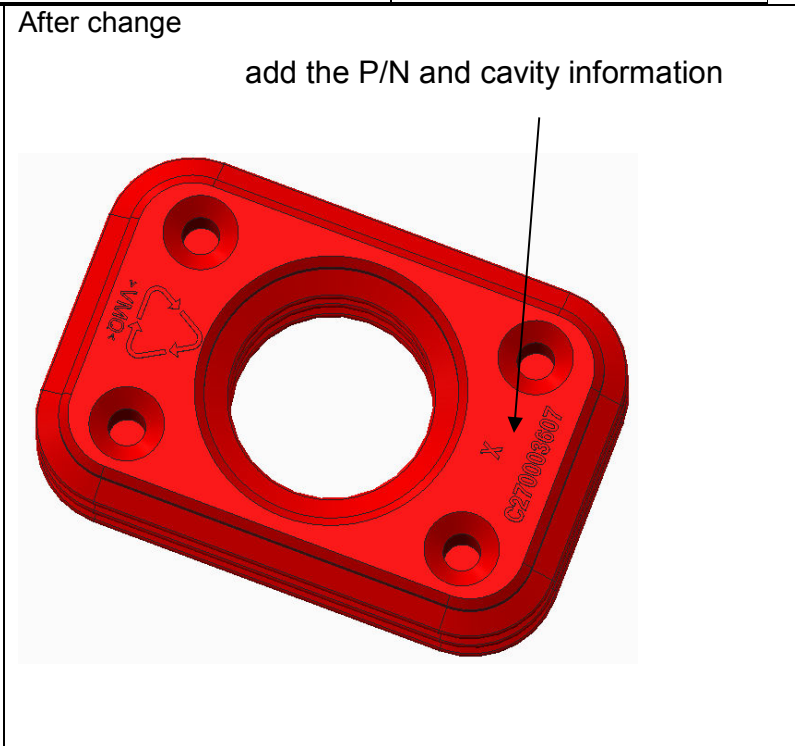
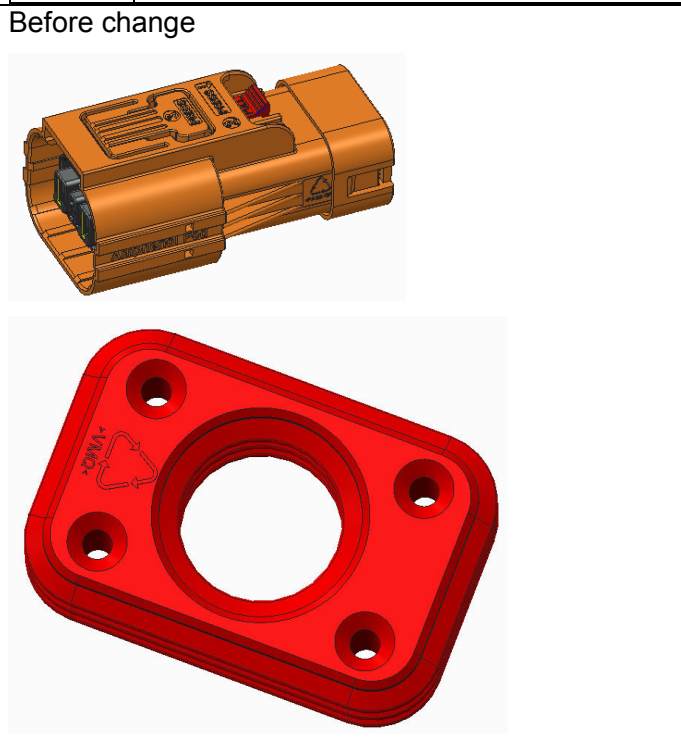

Disposition of old materials

Rework
 Use as it is
 scrap

Other (please describe): _____

N/A

Expect date to switch to new material

2023.12.30

Approval by the supervisor of requester.:

Semtao

Derek

Approval by the head manager of the request dept.:

Customer approval:

Approved
 No approved
 Conditional approval (please describe) :

Signature: _____ Date: _____

Remark: