USB-6008

Specifications

2023-02-12



Contents

USB-6008 Specifications..... 3

USB-6008 Specifications

Definitions

Warranted specifications describe the performance of a model under stated operating conditions and are covered by the model warranty.

Characteristics describe values that are relevant to the use of the model under stated operating conditions but are not covered by the model warranty.

- **Typical** specifications describe the performance met by a majority of models.
- **Nominal** specifications describe an attribute that is based on design, conformance testing, or supplemental testing.

Specifications are **Typical** unless otherwise noted.

Conditions

Specifications are valid at 25 °C unless otherwise noted.

Analog Input

| | | |
|-------------------------|------------------------|---------|
| Analog inputs | | |
| Differential | 4 | |
| Single-ended | 8, software-selectable | |
| Input resolution | | |
| Differential | | 12 bits |

| | |
|-----------------------------------|---|
| Single-ended | 11 bits |
| Maximum sample rate (aggregate) | 10 kS/s, system dependent |
| Converter type | Successive approximation |
| AI FIFO | 512 bytes |
| Timing resolution | 41.67 ns (24 MHz timebase) |
| Timing accuracy | 100 ppm of actual sample rate |
| Input range | |
| Differential | ± 20 V ^[1] , ± 10 V, ± 5 V, ± 4 V, ± 2.5 V, ± 2 V, ± 1.25 V, ± 1 V |
| Single-ended | ± 10 V |
| Working voltage | ± 10 V |
| Input impedance | 144 k Ω |
| Overvoltage protection | ± 35 V |
| Trigger source | Software or external digital trigger |
| System noise^[2] | |
| Differential | |
| ± 20 V range | 5 mV _{rms} |
| ± 1 V range | 0.5 mV _{rms} |

Single-ended, ± 10 V range $5 \text{ mV}_{\text{rms}}$

| Range (V) | Typical at 25 °C (mV) | Maximum over Temperature (mV) |
|------------|-----------------------|-------------------------------|
| ± 20 | 14.7 | 138 |
| ± 10 | 7.73 | 84.8 |
| ± 5 | 4.28 | 58.4 |
| ± 4 | 3.59 | 53.1 |
| ± 2.5 | 2.56 | 45.1 |
| ± 2 | 2.21 | 42.5 |
| ± 1.25 | 1.70 | 38.9 |
| ± 1 | 1.53 | 37.5 |

Table 1. Absolute Accuracy at Full Scale, Differential



Note Input voltages may not exceed the working voltage range.

| Range (V) | Typical at 25 °C (mV) | Maximum over Temperature (mV) |
|-----------|-----------------------|-------------------------------|
| ± 10 | 14.7 | 138 |

Table 2. Absolute Accuracy at Full Scale, Single-Ended

Analog Output

| | |
|---------------------|------------------------|
| Analog outputs | 2 |
| Output resolution | 12 bits |
| Maximum update rate | 150 Hz, software-timed |
| Output range | 0 V to +5 V |
| Output impedance | 50 Ω |

| | |
|------------------------------------|--------------|
| Output current drive | 5 mA |
| Power-on state | 0 V |
| Slew rate | 1 V/ μ s |
| Short circuit current | 50 mA |
| Absolute accuracy (no load) | |
| Typical | 7 mV |
| Maximum at full scale | 36.4 mV |

Digital I/O

| | |
|-----------------------------------|---|
| Digital I/O lines | |
| P0.<0..7> | 8 lines |
| P1.<0..3> | 4 lines |
| Direction control | Each channel individually programmable as input or output |
| Output driver type ^[3] | Open collector |
| Compatibility | TTL, LVTTTL, CMOS |
| Absolute maximum voltage range | -0.5 V to 5.8 V with respect to GND |
| Pull-up resistor | 4.7 k Ω to 5 V |

| Power-on state | | Input | |
|---|--|---------|------------|
| Level | | Minimum | Maximum |
| Input low voltage | | -0.3 V | 0.8 V |
| Input high voltage | | 2.0 V | 5.8 V |
| Input leakage current | | — | 50 μ A |
| Output low voltage (I = 8.5 mA) | | — | 0.8 V |
| Output high voltage, active drive (I = -8.5 mA) | | 2.0 V | 3.5 V |
| Output high voltage, open collector (I = -0.6 mA, nominal) | | 2.0 V | 5.0 V |
| Output high voltage, open collector (I = -8.5 mA, with external pull-up resistor) | | 2.0 V | — |

Table 3. Digital Logic Levels

External Voltage

| | |
|-------------------------------------|------------------------------|
| +5 V output (200 mA maximum) | |
| Minimum | +4.85 V |
| Typical | +5 V |
| +2.5 V output (1 mA maximum) | +2.5 V |
| +2.5 V accuracy | 0.25% maximum |
| Reference temperature drift | 50 ppm/ $^{\circ}$ C maximum |

Event Counter

| | |
|--------------------|---|
| Number of counters | 1 |
|--------------------|---|

| | |
|--------------------------|------------------------------|
| Resolution | 32 bits |
| Counter measurements | Edge counting (falling-edge) |
| Counter direction | Count up |
| Pull-up resistor | 4.7 k Ω to 5 V |
| Maximum input frequency | 5 MHz |
| Minimum high pulse width | 100 ns |
| Minimum low pulse width | 100 ns |
| Input high voltage | 2.0 V |
| Input low voltage | 0.8 V |

Bus Interface

| | |
|-------------------|------------------------------|
| USB specification | USB 2.0 full-speed (12 Mb/s) |
|-------------------|------------------------------|

Power Requirements

| | |
|----------------------------------|--------|
| USB, 4.10 VDC to 5.25 VDC | |
| Typical | 80 mA |
| Maximum | 500 mA |
| USB suspend | |

| | |
|---------|-------------|
| Typical | 300 μ A |
| Maximum | 500 μ A |

Physical Characteristics

| | |
|----------------------------|--|
| Dimensions | |
| Without connectors | 63.5 mm \times 85.1 mm \times 23.2 mm (2.50 in. \times 3.35 in. \times 0.91 in.) |
| With connectors | 81.8 mm \times 85.1 mm \times 23.2 mm (3.22 in. \times 3.35 in. \times 0.91 in.) |
| Weight | |
| Without connectors | 54 g (1.9 oz) |
| With connectors | 84 g (3 oz) |
| USB connector | USB series B receptacle (1) |
| I/O connectors | |
| Type | 16-position screw terminal plugs (2) |
| Screw-terminal wiring | 16 AWG to 28 AWG |
| Torque for screw terminals | 0.22 N \cdot m to 0.25 N \cdot m (2.0 lb \cdot in. to 2.2 lb \cdot in.) |

If you need to clean the module, wipe it with a dry towel.

Figure 1. USB-6008 Dimensions

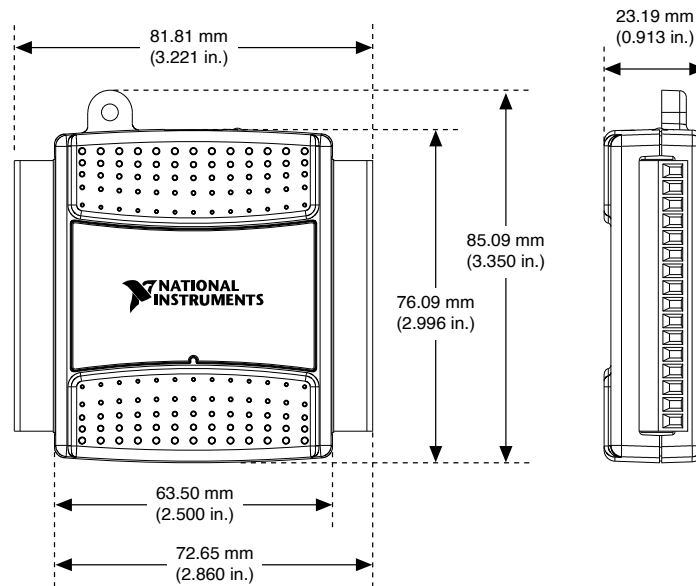

Safety Voltages

Connect only voltages that are within these limits.

| | |
|----------------|--|
| Channel-to-GND | ± 30 V max, Measurement Category I |
|----------------|--|

Measurement Category I is for measurements performed on circuits not directly connected to the electrical distribution system referred to as MAINS voltage. MAINS is a hazardous live electrical supply system that powers equipment. This category is for measurements of voltages from specially protected secondary circuits. Such voltage measurements include signal levels, special equipment, limited-energy parts of equipment, circuits powered by regulated low-voltage sources, and electronics



Caution Do not use this module for connection to signals or for measurements within Measurement Categories II, III, or IV



Note Measurement Categories CAT I and CAT O (Other) are equivalent. These test and measurement circuits are not intended for direct

connection to the MAINS building installations of Measurement Categories CAT II, CAT III, or CAT IV.

Environmental

| Temperature (IEC 60068-2-1 and IEC 60068-2-2) | |
|--|--------------------------------|
| Operating | 0 °C to 55 °C |
| Storage | -40 °C to 85 °C |
| Humidity (IEC 60068-2-56) | |
| Operating | 5% RH to 95% RH, noncondensing |
| Storage | 5% RH to 90% RH, noncondensing |
| Pollution Degree (IEC 60664) | 2 |
| Maximum altitude | 2,000 m |

Indoor use only.

Safety Compliance Standards

This product is designed to meet the requirements of the following electrical equipment safety standards for measurement, control, and laboratory use:

- IEC 61010-1, EN 61010-1
- UL 61010-1, CSA C22.2 No. 61010-1



Note For safety certifications, refer to the product label or the [Product Certifications and Declarations](#) section.

Electromagnetic Compatibility

CE Compliance

This product meets the essential requirements of applicable European Directives, as follows:

- 2014/35/EU; Low-Voltage Directive (safety)
- 2014/30/EU; Electromagnetic Compatibility Directive (EMC)
- 2011/65/EU; Restriction of Hazardous Substances (RoHS)
- 2014/53/EU; Radio Equipment Directive (RED)
- 2014/34/EU; Potentially Explosive Atmospheres (ATEX)

Product Certifications and Declarations

Refer to the product Declaration of Conformity (DoC) for additional regulatory compliance information. To obtain product certifications and the DoC for NI products, visit ni.com/product-certifications, search by model number, and click the appropriate link.

Environmental Management

NI is committed to designing and manufacturing products in an environmentally responsible manner. NI recognizes that eliminating certain hazardous substances from our products is beneficial to the environment and to NI customers.

For additional environmental information, refer to the **Engineering a Healthy Planet** web page at ni.com/environment. This page contains the environmental regulations and directives with which NI complies, as well as other environmental information not included in this document.

Waste Electrical and Electronic Equipment (WEEE)

EU Customers This symbol indicates that waste products should be disposed of separately from municipal household waste according to WEEE Directive 2002/96/EC of the European Parliament and the Council on waste electrical and electronic equipment (WEEE). All products at the end of their life cycle must be sent to a WEEE collection and recycling center. Proper WEEE disposal reduces environmental impact and the risk to human health due to potentially hazardous substances used in such equipment. Your cooperation in proper WEEE disposal will contribute to the effective usage of natural resources. For information about the available collection and recycling scheme in a particular country, go to ni.com/environment/weee.

电子信息产品污染控制管理办法（中国 RoHS）

-  **中国 RoHS**— NI 符合中国电子信息产品中限制使用某些有害物质指令(RoHS)。关于 NI 中国 RoHS 合规性信息，请登录 ni.com/environment/rohs_china。(For information about China RoHS compliance, go to ni.com/environment/rohs_china.)

¹ ± 20 V means that $|AI+ - (AI-)| \leq 20$ V. However, AI+ and AI- must both be within ± 10 V of GND. Refer to the **Taking Differential Measurements** section of the **NI USB-6008/6009 User Guide** for more information.

² System noise measured at maximum sample rate.

³ This document uses NI-DAQmx naming conventions. Open-drain is called open collector and push-pull is called active drive.