



Jan. 2022 Ver.6.1
TDK Corporation

Multilayer Directional Coupler

For 450-3800MHz

HHM Series 1.6x0.8mm [EIA 0603] TYPE

P/N: **HHM22152A2**

HHM22152A2

■ SHAPES AND DIMENSIONS

[Top View]



[Bottom View]

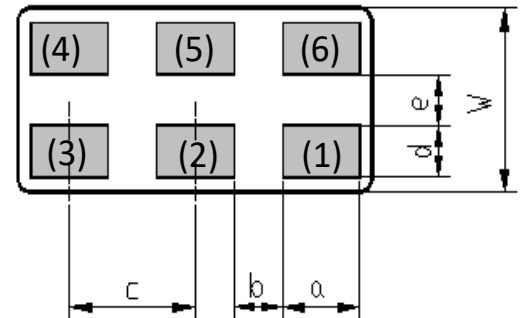

Dimensions (mm)

L	W	T	a	b	c	d	e
1.60	0.80	0.60	0.35	0.22	0.57	0.225	0.22
+/-0.05	+/-0.05	+/-0.05	+/-0.05	+/-0.05	+/-0.05	+/-0.05	+/-0.05

Terminal functions

(1)	Input Port
(2)	GND
(3)	Output Port
(4)	50ohm Termination
(5)	GND
(6)	Coupling Port

■ TERMINATION FINISH

Material
Au plate

HHM22152A2

■ ELECTRICAL CHARACTERISTICS

(Measurement)

Parameter	Frequency (MHz)	TDK Spec		
		Min.	Typ.	Max.
Coupling Factor (dB)	450 to 700	26.0	28.5	31.0
	700 to 2700	22.5	25.0	27.5
	2700 to 3400	22.3	23.4	27.5
	3400 to 3800	22.3	23.4	24.5
Insertion Loss (dB)	450 to 2700	-	0.18	0.25
	2700 to 3800	-	0.32	0.40
Isolation (dB)	450 to 2700	45	51.5	-
	2700 to 3800	40	59.7	-
Directivity (dB)	880 to 960	20	32.8	-
Return Loss(dB)	450 to 3800	10	15.0	-
Characteristic Impedance (ohm) (Input / Output Port) (Coupling / Termination Port)		50 (Nominal)		
		50 (Nominal)		

Ta = +25+/-5°C

Coupler Type

Daisy Chain Available	Yes
Bi-Directional	No

■ MAXIMUM RATINGS

Parameter	TDK Spec	Conditions	
Operating temperature (°C)	-40 to +90 °C		
Storage temperature (°C)	-40 to +90 °C		
Power Handling (W) *1	Frequency (MHz)		
	450 to 3800	3	CW
Human Body Model : HBM	@Each Port (V)	+/-1000	100pF / 1500ohm
Machine Model : MM	@Each Port (V)	+/-150	200pF / 0ohm
Charged Device Model : CDM	@Each Port (V)	+/-500	Humidity : 60%RH max

*1 : Refer to 3GPP TS 38.101-1 V15.2.0

HHM22152A2

■ FREQUENCY CHARACTERISTICS

Insertion Loss

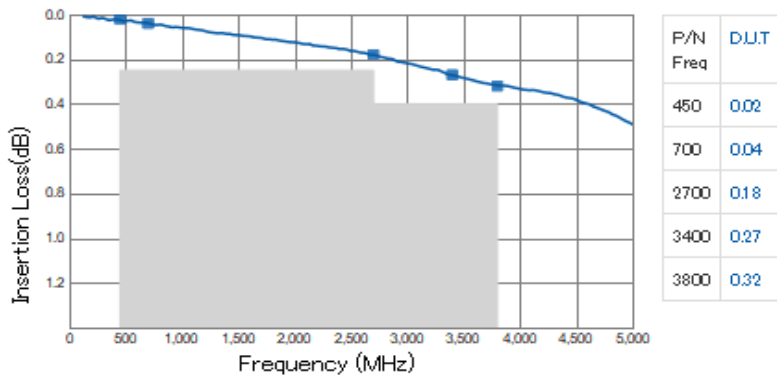

Coupling

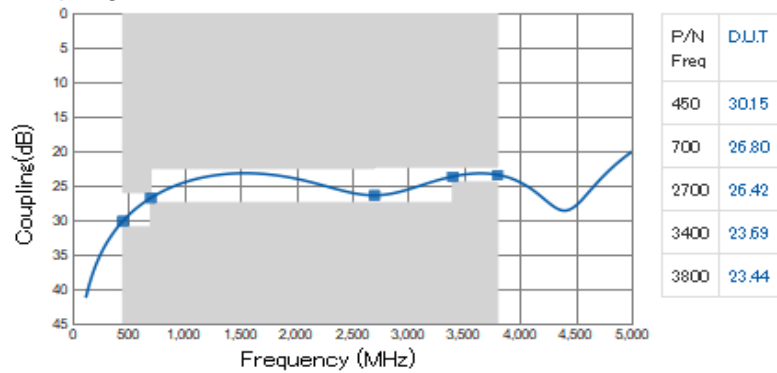

Isolation

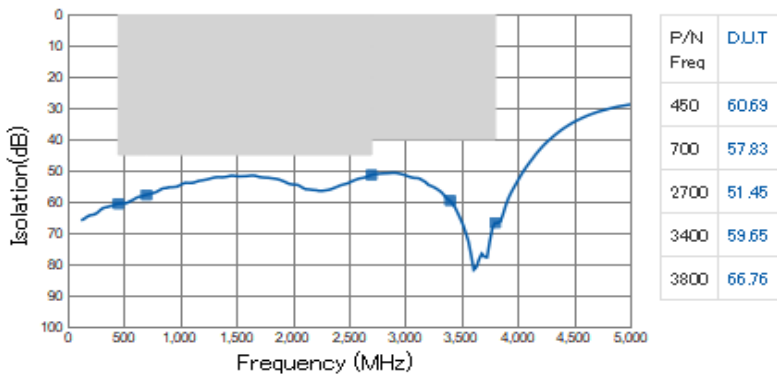

Return Loss

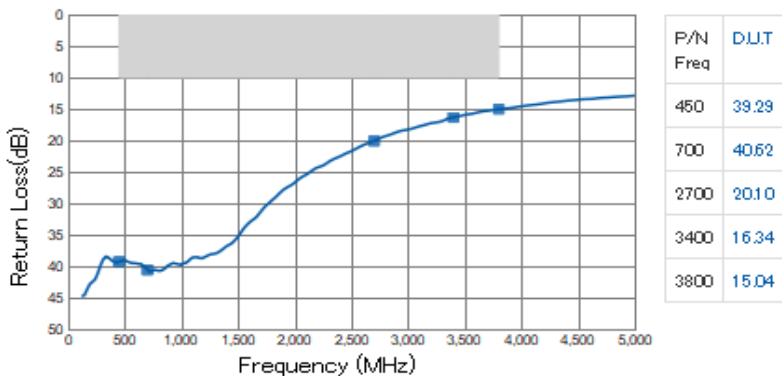

HHM22152A2

RECOMMENDED LAND PATTERN

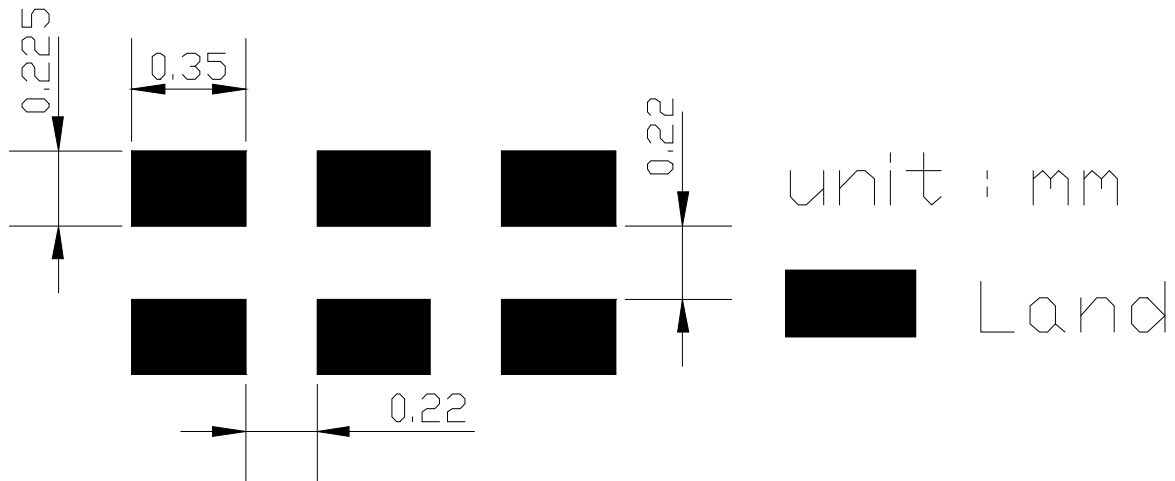

EVALUATION BOARD

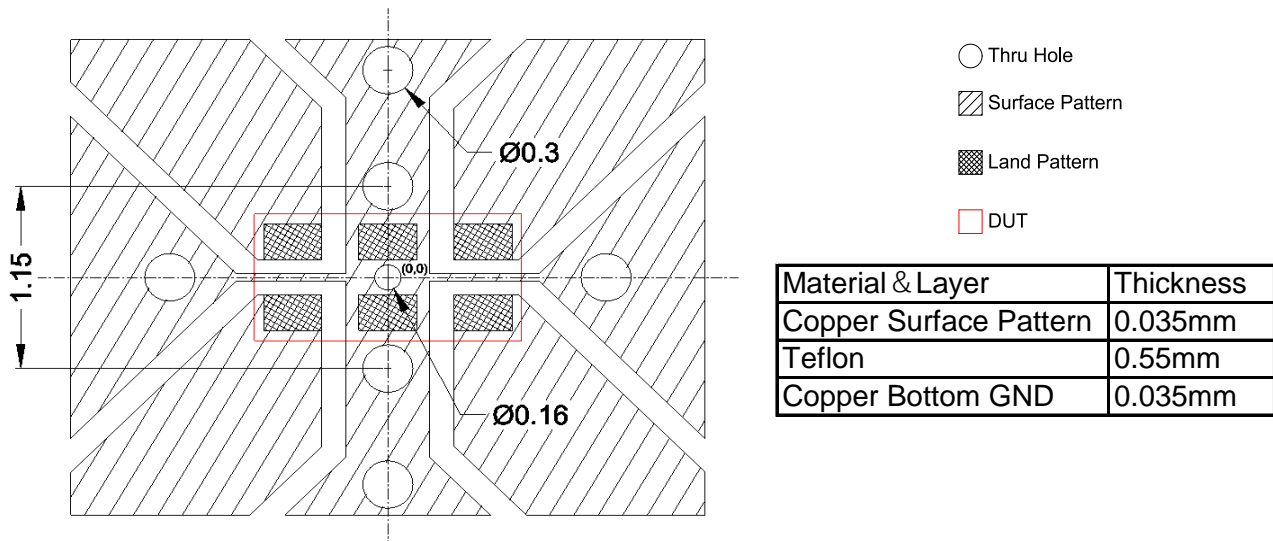

* Line width should be designed to match 50 ohm characteristic impedance depending on PCB material and thickness.

ENVIRONMENT INFORMATION

RoHS Statement
 RoHS Compliance

HHM22152A2

RECOMMENDED REFLOW PROFILE

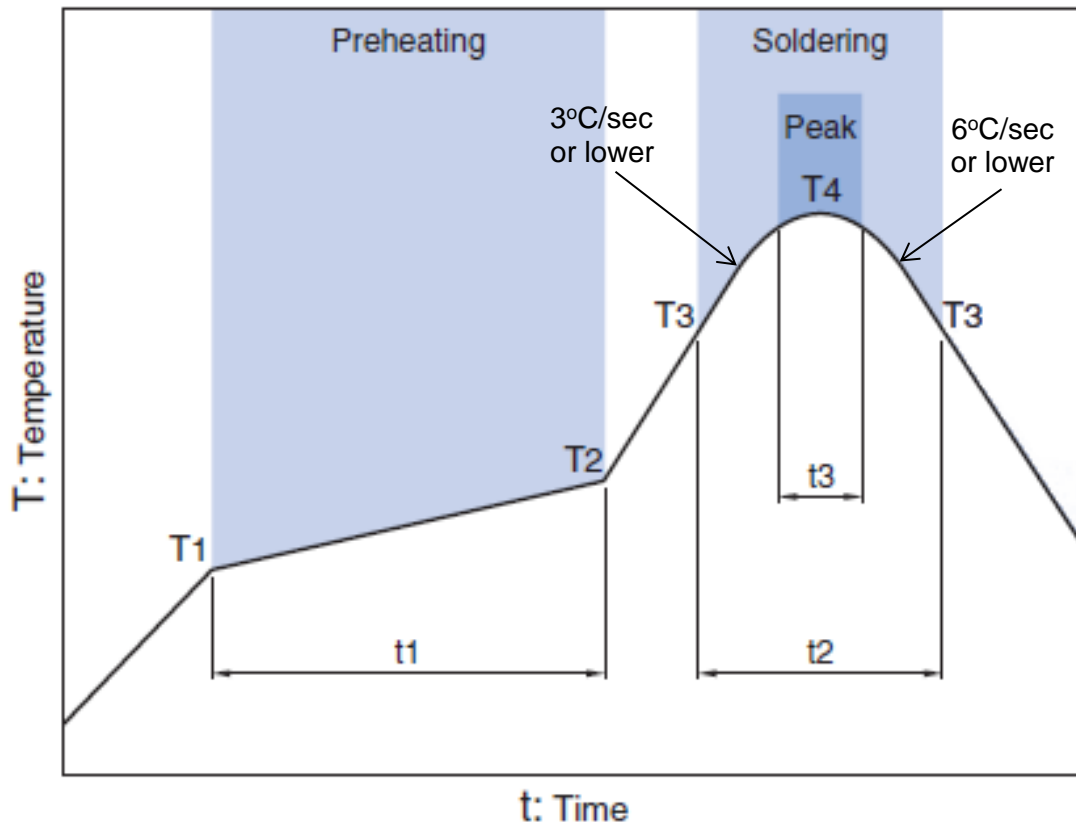

Preheating			Soldering			
			Critical zone (T3 to T4)		Peak	
Temp.	Temp.	Time	Temp.	Time	Temp.	Time
T1	T2	t1	T3	t2	T4	t3 *
150°C	200°C	60 to 120sec	217°C	60 to 120sec	240 to 260°C	30 sec Max

* t3 : Time within 5°C of actual peak temperature

The maximum number of reflow is 3.

Note: Lead free solder is recommended.
Recommended solder is Sn-3.0Ag-0.5Cu. (M705 by Senju Metal Industry)

GENERAL TECHNICAL INFORMATION

https://product.tdk.com/en/system/files?file=dam/doc/product/rf/rf/coupler/general_tech_info/rf_general-technical-info_02_en.pdf

HHM22152A2

PACKAGING STYLE

Reel Dimensions

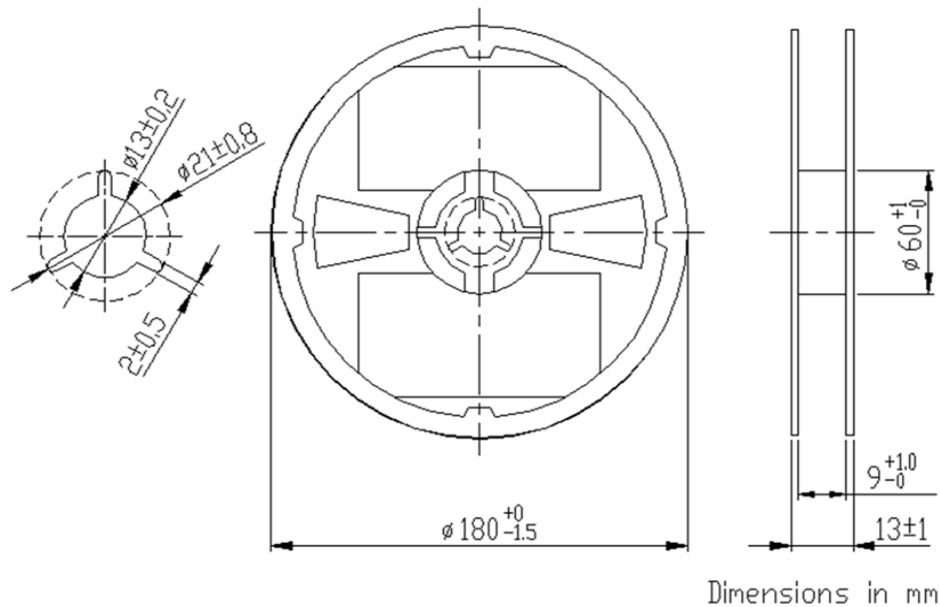

Carrier Tape

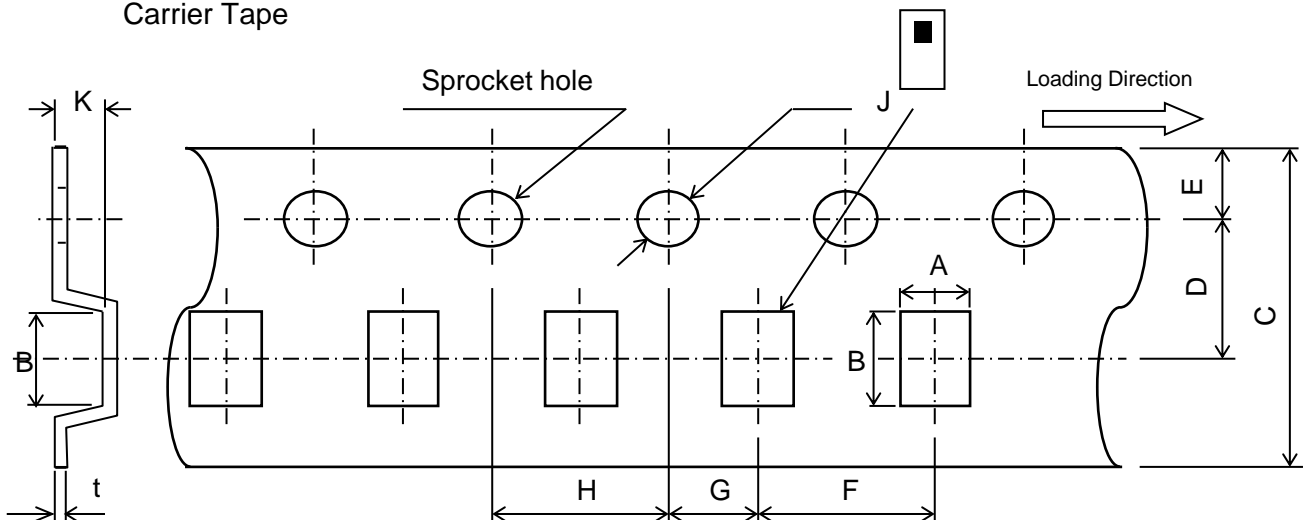

Dimensions (mm)

A	B	C	D	E	F	G	H	J	K	t
0.97	1.8	8.0	3.5	1.75	4.0	2.0	4.0	1.5	0.8	0.25
+/-0.05	+/-0.05	+/-0.2	+/-0.05	+/-0.1	+/-0.1	+/-0.05	+/-0.1	+0.1/-0	MAX	+/-0.05

STANDARD PACKAGE QUANTITY (pieces/reel)

4,000

REMINDERS FOR USING THESE PRODUCTS

Before using these products, be sure to request the delivery specifications.

SAFETY REMINDERS

Please pay sufficient attention to the warnings for safe designing when using these products.

REMINDERS

The products listed on this catalog are intended for use in general electronic equipment (AV equipment, telecommunications equipment, home appliances, amusement equipment, computer equipment, personal equipment, office equipment, measurement equipment, industrial robots) under a normal operation and use condition.

The products are not designed or warranted to meet the requirements of the applications listed below, whose performance and/or quality require a more stringent level of safety or reliability, or whose failure, malfunction or trouble could cause serious damage to society, person or property.

Please understand that we are not responsible for any damage or liability caused by use of the products in any of the applications below or for any other use exceeding the range or conditions set forth in this catalog.

- | | |
|---|--|
| (1) Aerospace/Aviation equipment | (8) Public information-processing equipment |
| (2) Transportation equipment (cars, electric trains, ships, etc.) | (9) Military equipment |
| (3) Medical equipment | (10) Electric heating apparatus, burning equipment |
| (4) Power-generation control equipment | (11) Disaster prevention/crime prevention equipment |
| (5) Atomic energy-related equipment | (12) Safety equipment |
| (6) Seabed equipment | (13) Other applications that are not considered general-purpose applications |
| (7) Transportation control equipment | |

When using this product in general-purpose applications, you are kindly requested to take into consideration securing protection circuit/equipment or providing backup circuits, etc., to ensure higher safety.