



8755 W. Higgins Road
Suite 500
Chicago, Illinois USA 60631

Feb-07th, 2023

PCN # ESW490-47 – Thyristor & Diode SOT-227 Packaging Location Transfer

To our valued customers,

Littelfuse would like to notify you that we will transfer our backend assembly process of Thyristor & Diode products SOT-227 Package to our new inhouse assembly factory in Lipa, Philippines. This brand-new assembly factory is to fulfill our strategy to invest in state-of-the-art power semiconductor assembly capabilities to dramatically improve our service levels to customers. Our target is to build this factory as a world class facility with automated, error proof processes to meet the highest quality standards. Contact our local Sales team in case you would like to understand more about this new factory.

Below is the detail changes associate with this Assembly Location change:

- 1) **Silicon Die:** No change
- 2) **Backend Assembly Bill of Materials:** No change
- 3) **Backend Assembly Process Flow:** Some part numbers change from Pad type to Padless type. Refer to PCN report.
- 4) **Backend Assembly Equipment:** Equal or better
- 5) **Marking & Labeling:** Yes. Changes pls refer to below details.

DESCRIPTION	EXISTING LOCATION	SBU-LIPA	CHANGE (Y/N)	RISK	REMARKS
Unit Marking					
Logo			Y	NR	Change to Littelfuse Logo
UL Sign	Yes	Yes	N	NR	No change
Product Name	Yes	Yes	N	NR	No change
Date Code	YYWW	YYWW	N	NR	No change
Assembly Line Code	G	M	Y	LOW	Site location code
Lot ID	Yes	Yes	N	NR	No Change
Tube Label					
Logo			Y	NR	Change to Littelfuse Logo
Qty per tube	Yes	Yes	N	NR	No change
Part Number	Yes	Yes	N	NR	No change
Lot No	No	Yes	Y	LOW	SBU-Lipa uses global format for product traceability
Country of Origin	No	Yes	Y	LOW	
Barcode + 2D Code	No	Yes	Y	LOW	
Date Code	Yes	Yes	N	NR	No change
Assy Line Code	G	M	Y	LOW	Site location code
Product code	Yes	No	Y	LOW	SBU-Lipa uses global format for product traceability
Box Label					
RoHS Label			Y	LOW	Both boxes having the notification of compliance with RoHs
Logo			Y	NR	Change to Littelfuse Logo
Qty per tube	Yes	Yes	N	NR	No change
Part Number	Yes	Yes	N	NR	No change
Lot No	No	Yes	Y	LOW	SBU-Lipa uses global format for product traceability
Country of Origin	No	Yes	Y	LOW	
Barcode + 2D Code	No	Yes	Y	LOW	
Date Code	Yes	Yes	N	NR	No change
Assy Line Code	G	M	Y	LOW	Site location code
Product code	Yes	No	Y	LOW	SBU-Lipa uses global format for product traceability

Form, fit, function changes: None
Part number changes: None
Effective date: March-07th, 2023
Replacement products: N/A
Last time buy: N/A

This notification is for your information and acknowledgement. If you have any other questions or concerns, please contact your local sales team or Zhiwei Wang, Power Thyristor/Diode Discrete, Product Marketing Manager.

We value your business and look forward to assisting you whenever possible.

Thank you very much!

Zhiwei Wang

Best Regards,

Zhiwei Wang
Product Marketing Manager of Power Thyristor/Diode Discrete
Semiconductor Business Unit, Wuxi, China
+86 510 85277701 - 7927
zwang@littelfuse.com

Littelfuse Phils, Inc. Lipa, Philippines



- Established since November 1997
- New Building 3 be opened in March 2020
- A two stories building (EBU & SBU)
- Total production space ~8400 m²
- 3400 m² used in phase 1
- Dedicated to semiconductor products





800 E. Northwest Highway Des Plaines, IL 60016

Product/Process Change Notice (PCN)

PCN#: ESW490-47 **Date:** Feb-07th, 2023

Product Identification:

Thyristor & Diode SOT-227 Package Products

Implementation Date for Change:

March-07th, 2023

Contact Information

Name: Zhiwei Wang

Title: Product Marketing Manager

Phone #: +86 510 85277701 - 7927

Fax#: N/A

E-mail: zwang@littelfuse.com

Category of Change:

- Assembly Process
- Data Sheet
- Technology
- Discontinuance/Obsolescence
- Equipment
- Manufacturing Site
- Raw Material
- Testing
- Fabrication Process
- Other: _____

Description of Change:

Littelfuse would like to notify you that we will transfer our backend assembly process of Thyristor/Diode SOT-227 Package Products to our inhouse new factory in Lipa, Philippines.

- 1) Silicon Die: No change
- 2) Backend Assembly Bill of Materials: No change
- 3) Backend Assembly Process Flow: Some part numbers change from Pad type to Padless type. Refer to PCN report.
- 4) Backend Assembly Equipment: Equal or better
- 5) Marking & Labeling: Yes. (refer to PCN letter)

Product form, fit, function changes: None

Part number changes: None

Important Dates:

- Qualification Samples Available: Last Time Buy:
- Final Qualification Data Available:
- Date of Final Product Shipment:

Method of Distinguishing Changed Product

- Product Mark,
- Date Code,
- Other,

Demonstrated or Anticipated Impact on Form, Fit, Function or Reliability:

None

LF Qualification Plan/Results:

Detail schedule refer to PCN report.

Customer Acknowledgement of Receipt: Littelfuse requests you acknowledge receipt of this PCN. In your acknowledgement, you can grant approval or request additional information. Littelfuse will assume the change is acceptable if no acknowledgement is received within 30 days of this notice. Lack of any additional response within 90 days of PCN issuance further constitutes acceptance of the change.

PCN Report

Prepared By : Zhiwei Wang, Product Marketing Manager
Date : Feb 07th, 2023
Products : Thyristor/Diode SOT-227 Package Products
Revision : B

1.0 Objective:

This qual report covers Thyristor/Diode SOT-227 Package Products Assembly location Transfer.

2.0 Applicable Products:

Thyristor/Diode SOT-227 Package Products.
Refer to Appendix A for detail affected part number list.

3.0 Physical Differences/Changes:

- 1) Small part numbers changed Assy process from Pad type to Padless type. Padless type is widely used for other SOT-227 package part numbers and is considered as a process improvement during the transfer.

Detail changed part numbers pls refer to Appendix B - Pad Type to Pad Less DCB Part List

Pad Type

Padless type (DCB based Assy)

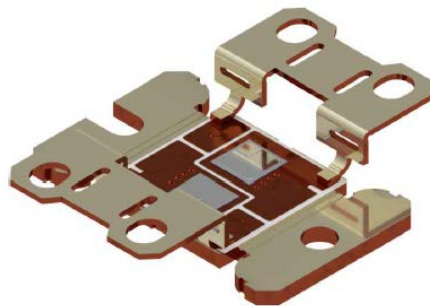
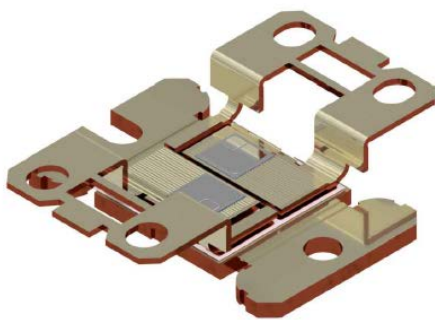

- 2) Small Tube dimension difference but do not impact customer application

Existing location Tube with gap:

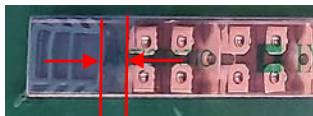

SBU Lipa Tube without gap:

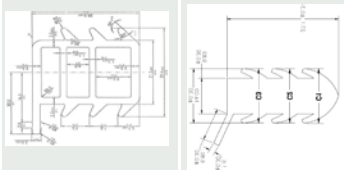

Point of Comparison	EXISTING LOCATION	SBU-LIPA	GAP	RISK
Shipping Tube				
Length, mm	566	533	Yes	Low risk. Both tubes have the same quantity of units but SBU-Lipa tube does not allow unit movement after placing the screws (enclosed in anti-static bag) and installing the end plugs. This is also standard to other OSAT
Width, mm	28	28.45	Yes	Low risk. Gap is not significant. SBU-Lipa tube not causing any jamming issue at DTFS and final test tube handlers
Height, mm	15	15.24	Yes	Low risk. Gap is not significant. SBU-Lipa tube not causing any jamming issue at DTFS and final test tube handlers
Material Thickness, mm	0.81	0.89	Yes	Low risk. Gap is not significant.
Tube Opening, mm	26.68 x 13.23	26.67 x 13.46	Yes	Low risk. Gap is not significant. SBU-Lipa tube not causing any jamming issue at DTFS and final test tube handlers
Quantity	10	10	No gap	No risk
Anti-static	Yes	Yes	No gap	No risk
End Plug				
Length, mm	26.3	27.10	Yes	Low risk. No risk of falling unit due to end plug design. SBU-Lipa is using an open tool design and does not allow unit movement when installed
Width, mm	21.2	24.50		
Height, mm	12	14		
Design				

4.0 Qualification Test Result

All samples passed parametric and reliability test standard by Littelfuse/IXYS.

DEVICE	REL - TEST	CONDITIONS	SAMPLE SIZE PER LOT	STATUS	E22D14B1	RESULT
MMO74-12IO6Y	Autoclave/U-HAST	168h, 85°C/85%r.H.	20	finished	passed	Completed; Passed reliability
	T/C	100 cycles, -40/+150°C	20	finished	passed	Completed; Passed reliability
	ITSM	Datasheet	3	finished	passed	Completed; Passed reliability

DEVICE	REL - TEST	CONDITIONS	SAMPLE SIZE PER LOT	STATUS	E22H33B1	E22H33B2	E22H33B3	RESULT
DMA100A1600NB	Autoclave/U-HAST	168h, 85°C/85%r.H.	20	finished	passed	passed	passed	Completed; Passed reliability
	T/C	100 cycles, -40/+150°C	20	finished	passed	passed	passed	Completed; Passed reliability
	ITSM	Datasheet	3	finished	passed	passed	passed	Completed; Passed reliability

DEVICE	REL - TEST	CONDITIONS	SAMPLE SIZE PER LOT	STATUS	E22D13B4	E22D13B5	RESULT
DPJ50XS1800NA	Autoclave/U-HAST	168h, 85°C/85%r.H.	20	finished	passed	passed	Completed; Passed reliability
	T/C	100 cycles, -40/+150°C	20	finished	passed	passed	Completed; Passed reliability
	ITSM	Datasheet	3	finished	passed	passed	Completed; Passed reliability
	HTRB	1000h, 125/150 C, 70% VDRM /V RRM	20	finished	passed	passed	Completed; Passed reliability
	PC	delta T = 80°C, TJJ = 125°C, 1000 cycles	20	finished	passed	passed	Completed; Passed reliability

DEVICE	REL - TEST	CONDITIONS	SAMPLE SIZE PER LOT	STATUS	E22I38B1	E22I38B2	RESULT
DSEI2x101-12A	Autoclave/U-HAST	168h, 85°C/85%r.H.	20	finished	passed	passed	Completed; Passed reliability
	T/C	100 cycles, -40/+150°C	20	finished	passed	passed	Completed; Passed reliability
	ITSM	Datasheet	3	finished	passed	passed	Completed; Passed reliability



5.0 Recommendations & Conclusions:

Based on the above qualification test results, Littelfuse concluded new Alternative Assembly Location can pass the release criterion and ready to start mass production for affected products.

Appendix A: Detail Part Number list affected

CLA100PD1200NA	DSEI2X101-06A	DSS2X111-008A
CLA110MB1200NA	DSEI2X101-12A	DSS2X121-0045B
CLA60PD1200NA	DSEI2X121-02A	DSS2X160-0045A
CMA80PD1600NA	DSEI2X30-04C	DSS2X160-01A
DAA200X1800NA	DSEI2X30-06C	DSS2X41-01A
DAA200XA1800NA	DSEI2X30-10B	DSS2X61-0045A
DFE240X600NA	DSEI2X30-12B	DSS2X61-01A
DFE250X600NA	DSEI2X31-04C	DSS2X81-0045B
DH2X60-18A	DSEI2X31-06C	MCD40-12IO6
DH2X61-18A	DSEI2X31-10B	MCD40-16IO6
DHG100X1200NA	DSEI2X31-12B	MCO100-12IO1
DHG100X600NA	DSEI2X60-04C	MCO100-16IO1
DHG100X650NA	DSEI2X61-02A	MCO150-12IO1
DHG50X1200NA	DSEI2X61-04C	MCO150-16IO1
DHG50X650NA	DSEI2X61-06C	MCO25-12IO1
DMA100A1600NB	DSEI2X61-10B	MCO25-16IO1
DMA150E1600NA	DSEI2X61-12B	MCO50-12IO1
DMA150YA1600NA	DSEK300-06A	MCO50-16IO1
DMA150YC1600NA	DSEP2X101-04A	MCO75-12IO1
DMA200X1600NA	DSEP2X25-12C	MCO75-16IO1
DMA200XA1600NA	DSEP2X31-03A	MMO62-12IO6
DMA200YA1600NA	DSEP2X31-06A	MMO62-16IO6
DMA200YC1600NA	DSEP2X31-06B	MMO74-12IO6
DMA240YA1600NA	DSEP2X31-12A	MMO74-16IO6
DMA240YC1600NA	DSEP2X60-12A	MMO90-12IO6
DNA90YA2200NA	DSEP2X61-03A	MMO90-14IO6
DNA90YC2200NA	DSEP2X61-06A	MMO90-16IO6
DPF240X200NA	DSEP2X61-12A	VBE60-06A
DPF240X400NA	DSEP2X61-12B	VBE60-12A
DPJ50XS1800NA	DSEP2X91-03A	VBO40-08NO6
DSA240X150NA	DSEP2X91-06A	VBO40-12NO6
DSA240X200NA	DSI2X55-12A	VBO40-16NO6
DSA320A100NB	DSI2X55-16A	DSEI2X101-12A-REG
DSEC240-04A	DSS2X101-015A	DSEI2X121-02Y
DSEC240-06A	DSS2X101-02A	MMO74-12IO6Y



PCN Report

Appendix B - Pad Type to Pad Less DCB Part List

Part Numbers	From Connector	To Connector			
CLA110MB1200NA	Pad Type	Padless	DSS2X101-02A	Pad Type	Padless
DHG100X1200NA	Pad Type	Padless	DSS2X111-008A	Pad Type	Padless
DSEI2X101-06A	Pad Type	Padless	DSS2X121-0045B	Pad Type	Padless
DSEI2X101-12A	Pad Type	Padless	DSS2X41-01A	Pad Type	Padless
DSEI2X121-02A	Pad Type	Padless	DSS2X61-0045A	Pad Type	Padless
DSEI2X121-02Y	Pad Type	Padless	DSS2X61-01A	Pad Type	Padless
DSEI2X31-04C	Pad Type	Padless	DSS2X81-0045B	Pad Type	Padless
DSEI2X31-06C	Pad Type	Padless	MMO62-12IO6	Pad Type	Padless
DSEI2X31-10B	Pad Type	Padless	MMO62-16IO6	Pad Type	Padless
DSEI2X61-02A	Pad Type	Padless	MMO74-12IO6	Pad Type	Padless
DSEI2X61-04C	Pad Type	Padless	MMO74-12IO6Y	Pad Type	Padless
DSEI2X61-06C	Pad Type	Padless	MMO74-16IO6	Pad Type	Padless
DSEI2X61-12B	Pad Type	Padless	MMO90-12IO6	Pad Type	Padless
DSEP2X101-04A	Pad Type	Padless	MMO90-14IO6	Pad Type	Padless
DSEP2X31-03A	Pad Type	Padless	MMO90-16IO6	Pad Type	Padless
DSEP2X31-06A	Pad Type	Padless	DH2X60-18A	Pad Type	Padless
DSEP2X31-12A	Pad Type	Padless	DSEI2X30-04C	Pad Type	Padless
DSEP2X60-12A	Pad Type	Padless	DSEI2X30-06C	Pad Type	Padless
DSEP2X61-03A	Pad Type	Padless	DSEI2X30-10B	Pad Type	Padless
DSEP2X61-06A	Pad Type	Padless	DSEI2X60-04C	Pad Type	Padless
DSEP2X61-12A	Pad Type	Padless	MCO100-12IO1	Pad Type	Padless
DSEP2X91-03A	Pad Type	Padless	MCO100-16IO1	Pad Type	Padless
DSEP2X91-06A	Pad Type	Padless	MCO150-12IO1	Pad Type	Padless
DSI2X55-12A	Pad Type	Padless	MCO150-16IO1	Pad Type	Padless
DSI2X55-16A	Pad Type	Padless	MCO50-12IO1	Pad Type	Padless
DSS2X101-015A	Pad Type	Padless	MCO50-16IO1	Pad Type	Padless
			MCO75-12IO1	Pad Type	Padless
			MCO75-16IO1	Pad Type	Padless