

Eaton Green Motion Building Pro

Eaton Green Motion Building Pro provides fast and cost-effective charging for passenger vehicles and medium-duty trucks. With breakout capabilities for metering, control, integrated communications and flexible installation options, the Eaton Green Motion Building Pro helps simplify infrastructure upgrades, charger deployment and energy management.

Providing a 11.5 kW AC charge, the Green Motion Building Pro powers commercial and destination charging for plug-in hybrid and all-electric vehicles. The Eaton chargers are compatible with the Society of Automotive Engineers J1772 charging standard.

- Enable safe, fast and flexible AC Level 2 charging for passenger and medium-duty EV trucks
- Manage energy usage through digital capabilities
- Throttle the rate of charge for dynamic load management, minimizing the impact on power distribution & grid infrastructure
- Gain real-time insights through energy metering and Wi-Fi, Ethernet and Cellular connectivity
- Secure access for authorized users through RFID cards
- Support an easy and intuitive charging experience with a 5" LCD touchscreen display
- Field adjustable output between 32 A, 40 A and 48 A based on infrastructure capacity
- Flexible installations including wall mount, single or dual pedestal mount

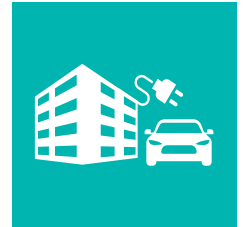

Powering Business Worldwide



EV wall charger & pedestal options

CATALOG & DESCRIPTION

GMEV48CME1-WC

- 11.5 kW AC Level 2 wall charger
- J1772 EV connector and 25 ft. cordset
- Mounting option: wall or pedestal
- Connectivity: Wi-Fi, Ethernet

GMEV48CMC1-WC

- 11.5 kW AC Level 2 wall charger
- J1772 EV connector and 25 ft. cordset
- Mounting option: wall or pedestal
- Connectivity: Wi-Fi, Ethernet; Cellular

GMEV-PED

- EV single port pedestal
- Requires (1) GMEV48CME1-WC/GMEV48CMC1-WC, sold separately

GMEV-DPED

- EV dual port pedestal
- Requires (2) GMEV48CME1-WC/GMEV48CMC1-WC, sold separately

Technical Specification

Input electrical ratings

- Voltage: single phase, 208-240Vac, 60 Hz
- Breaker rating: 60 A
- Power: 11.5 kW at 240 Vac; 9.9 kW at 208 Vac

Output electrical ratings

- Voltage: 208-240 Vac, 60 Hz
- Max current: 48 A
- Power: 11.5 kW at 240 Vac; 9.9 kW at 208 Vac

Adjustable output

- Yes. Output adjustable to 48 A, 40 A, 32 A

Output current rating	Required input breaker rating
48 A	60 A
40 A	50 A
32 A	40 A

Wiring options

- Hardwire

Output cable

- 25' cable
- J1772 compliant connector

Metering

- 1% accurate energy meter

Indicators

- 5" touch LCD
- Charging status indicator LED
- Audible alarm

Wireless connectivity

- Wi-Fi 802.11n (2.4 GHz)
- Ethernet/1 GB
- Cellular: 4G LTE

Cybersecurity

- Tested per cybersecurity guidelines endorsed by UL and IEC

Firmware features

- Open platform with support for OCPP (Open Charge Point Protocol) 1.6J
- Over-the-air (OTA) firmware updates

Enclosure

- NEMA 3R rated enclosure for indoor and outdoor installation
- Enclosure material: Sabic Noryl PX9406P
- Dimensions: 15.7"x11.4"x5.1"

Weight

- Charger enclosure plus cable: 29lbs

Certifications

- Safety: UL, CSA, NFPA article 625
- SAE J1772 2017 Ed.
- FCC compliant, Part 15
- Energy star

Warranty

- 3 years

Product dimensions

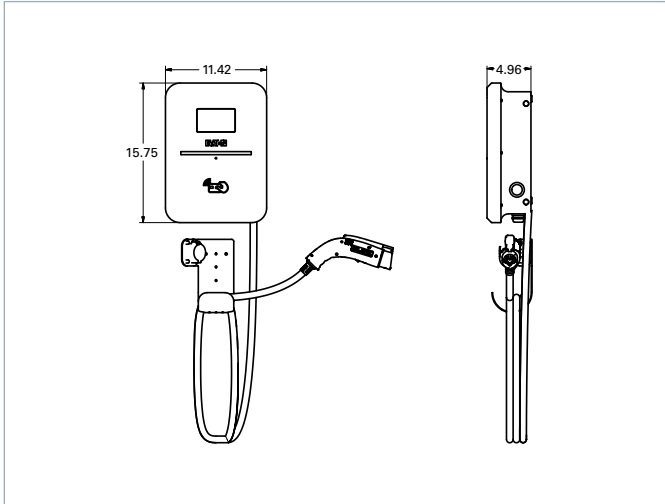

EV wall charger

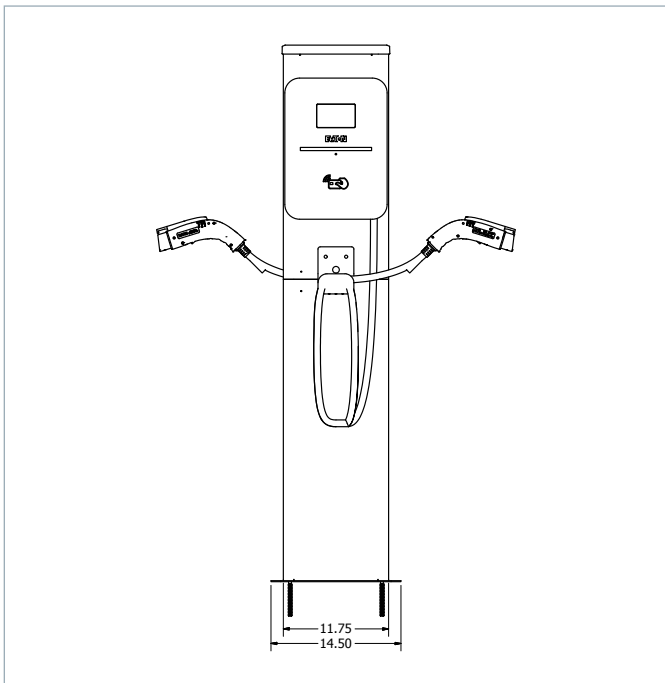

EV single port pedestal

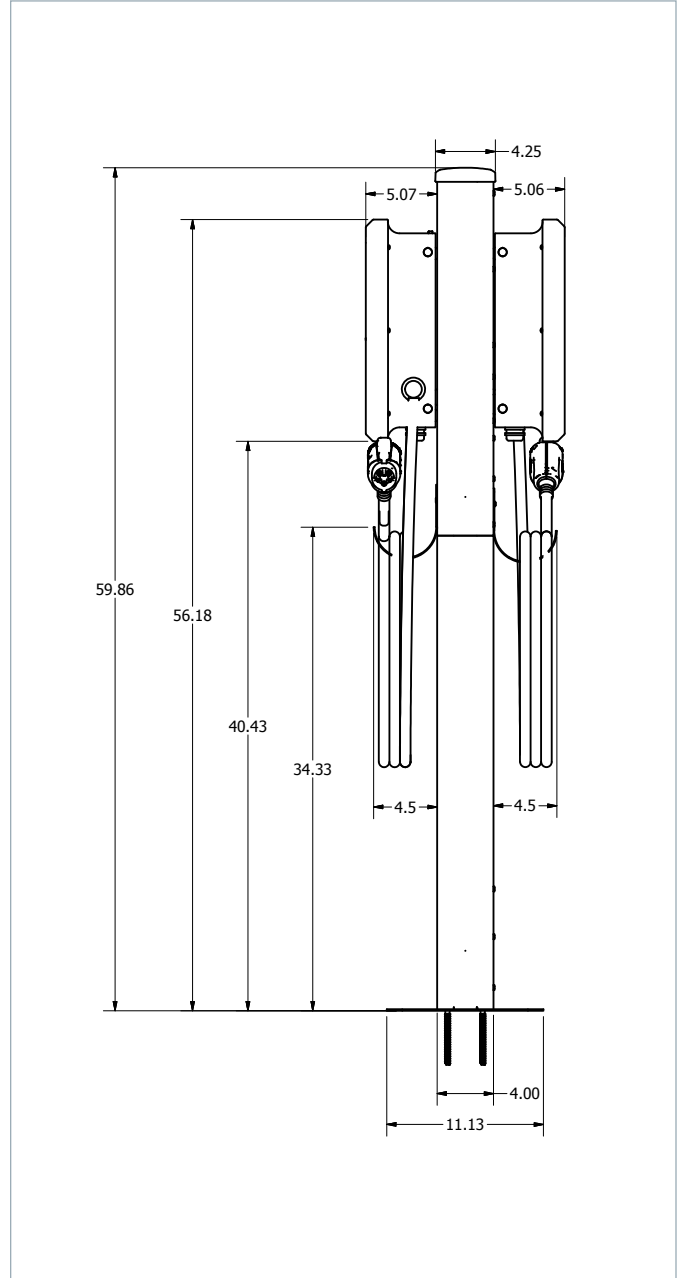

EV dual port pedestal

Contact the Eaton Technical Resource Center at

1-877-ETN-CARE (386-2273) option 2, option 9 for further assistance.

Eaton
 1000 Eaton Boulevard
 Cleveland, OH 44122
 United States
 Eaton.com

© 2022 Eaton
 All Rights Reserved
 TD191013EN/wB
 August 2022



Eaton is a registered trademark.
 All other trademarks are property
 of their respective owners.

Follow us on social media to get the
 latest product and support information.

