

PRODUCT SPECIFICATION

Part Number	USB4520	Rev	A1	Date	22/03/23		
Product Description	USB Type C Receptacle for USB 2.0, SMT Type, Mid Mount, 2.0mm Offset			Page	1		
Doc Number	USB Type C	Prepared	CC	Checked	VJ	Approved	PH

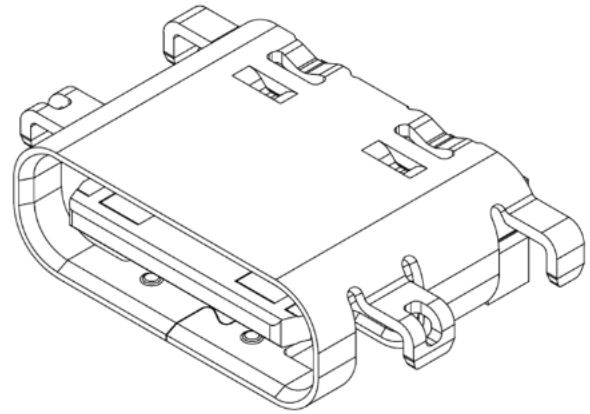
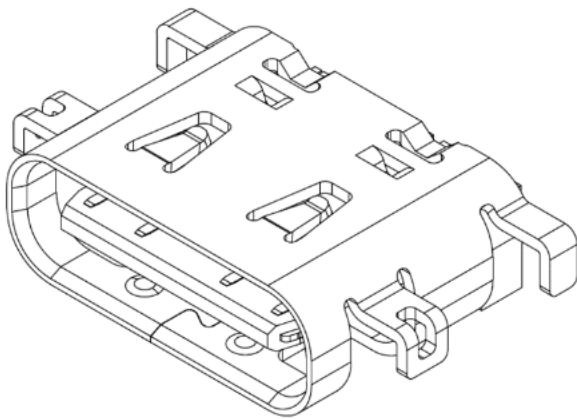

PRODUCT SPECIFICATION

Part Number	USB4520	Rev	A1	Date	22/03/23		
Product Description	USB Type C Receptacle for USB 2.0, SMT Type, Mid Mount, 2.0mm Offset			Page	2		
Doc Number	USB Type C	Prepared	CC	Checked	VJ	Approved	PH

1.0 SCOPE

This specification covers performance, tests and quality requirements for the USB Type C Receptacle USB4520.

2.0 PRODUCT NAME AND PART NUMBER

USB Type C Receptacle USB4520.

3.0 PRODUCT SHAPE, DIMENSIONS AND MATERIAL

Please refer to drawing.

4.0 RATINGS

4.1 Current rating: 5.00A collectively for VBUS pins (i.e., pins A4, A9, B4, and B9)

6.25A collectively for GND pins (i.e., pins A1, A12, B1, and B12)

1.25A for VCONN (i.e., A5/B5)

0.25A for all other pins, per pin

4.2 Voltage rating 48V DC

4.3 Power rating 240W

4.4 Operating Temperature Range -25°C to +85°C

5.0 TEST AND MEASUREMENT CONDITIONS

Product is designed to meet electrical, mechanical and environmental performance requirements specified below. All tests are performed in ambient conditions unless otherwise specified.

6.0 PERFORMANCE

Test No	Item	Test Condition	Requirement
6.0.1	Examination of Product	Visual, dimensional and functional inspection as per quality plan.	Product shall meet requirements of product drawing and specification.
	Reseating	Manually plug/unplug 3 times	No physical damage

PRODUCT SPECIFICATION

Part Number	USB4520	Rev	A1	Date	22/03/23		
Product Description	USB Type C Receptacle for USB 2.0, SMT Type, Mid Mount, 2.0mm Offset			Page	3		
Doc Number	USB Type C	Prepared	CC	Checked	VJ	Approved	PH

6.1 Electrical Performance

Test No	Item	Test Condition	Requirement
6.1.1	Low Level Contact Resistance	The low level contact resistance measurement is made from the solder tail of the receptacle to the soldering point of the plug. When measured at 20mV Max. open circuit at 100mA. Mated test contacts must be in a connector housing. In accordance with EIA-364-23, Test Condition B	40mΩ max (initial)
6.1.2	Insulation Resistance	Both unmated and Mated connectors, apply 100V DC for 1 minute at sea level between adjacent terminal or ground. In accordance with EIA-364-21.	100 MΩ Min (initial)
6.1.3	Dielectric Strength	Mate connectors, apply 100V AC (RMS) for 1 minute at sea level. In accordance with EIA-364-20.	No Breakdown
6.1.4	Contact current rating	A current of 5 A shall be applied collectively to VBUS pins (i.e., pins A4, A9, B4, and B9) and 1.25 A shall be applied to the VCONN pin (i.e., B5) as applicable, terminated through the corresponding GND pins (i.e., pins A1, A12, B1, and B12). A minimum current of 0.25 A shall also be applied individually to all the other contacts, as applicable.	The temperature rise shall not exceed 30°C at the outside surface of the shell.

PRODUCT SPECIFICATION

Part Number	USB4520	Rev	A1	Date	22/03/23		
Product Description	USB Type C Receptacle for USB 2.0, SMT Type, Mid Mount, 2.0mm Offset			Page	4		
Doc Number	USB Type C	Prepared	CC	Checked	VJ	Approved	PH

6.2 Mechanical Performance

Test No	Item	Test Condition	Requirement
6.2.1	Mating/Un-mating Force	Mate/Un-mated at a speed of 12.5mm/min. In accordance with EIA-364-13.	Mating force: within 5N to 20N (initial). Un-Mating force: within 8N to 20N up to 30cycles, within 6N to 20N after 10,000cycles
6.2.2	Durability	10,000 cycles at a cycle rate 500± 50per hour In accordance with EIA-364-09.	Un-Mating force: within 6N to 20N Contact resistance: 50mΩ max Dielectric Strength: no breakdown
	Durability (Preconditioning)	50 cycles at a cycle rate 500± 50 per hour In accordance with EIA-364-09.	-
6.2.3	Vibration	EIA 364-28 Test Condition VII, Test Letter D 15 minutes in each of 3 mutually perpendicular directions. Both mating halves should be rigidly fixed so as not to contribute to the relative motion of one contact against another. The method of fixturing should be detailed in the test report	No evidence of physical damage and no discontinuity longer than 1 microsecond. Contact resistance: 50mΩ max.
6.2.4	4-Axis Continuity	Shall be tested for continuity under stress using a test fixture	No evidence of physical damage and no discontinuity longer than 1 microsecond.

PRODUCT SPECIFICATION

Part Number	USB4520	Rev	A1	Date	22/03/23		
Product Description	USB Type C Receptacle for USB 2.0, SMT Type, Mid Mount, 2.0mm Offset			Page	5		
Doc Number	USB Type C	Prepared	CC	Checked	VJ	Approved	PH

6.3 Environmental Performance and Others

Test No	Item	Test Condition	Requirement
6.3.1	Cyclic Temperature and Humidity Test	Cycle the connector between 25 °C ±3 °C at 80 % ±3% RH and 65 °C ±3 °C at 50 % ±3% RH. Ramp times should be 0.5 hour and dwell times should be 1.0 hour. Dwell times start when the temperature and humidity have stabilized within the specified levels. Perform 24 such cycles.	Contact Resistance: 50mΩ Max.
6.3.2	Salt Spray	Subject mated connectors to 5±1% salt-solution concentration, 35±2°C for 24 hours. In accordance with EIA-364-26, Test Condition B.	Shall meet visual requirements, no detrimental corrosion allowed in contact area and base metal exposed.
6.3.3	Thermal Shock	Temperature range from -55°C~+85°C. Start from -55°C. After 30 min. change to +85°C, change time is no more than 5min. Total 10 cycles. Test reference standard: EIA 364-32, test condition I	No physical damage. Contact Resistance (Low Level) 50m max.
6.3.4	Solderability	Solder pot temperature: 250±5°C for 3~5 seconds. In accordance with EIA-364-52.	95% of immersed area must show no voids, pin holes.
6.3.5	Temperature life	105° C without applied voltage for 120 hours. EIA-364-17, method A	Contact resistance: 50mΩ max
	Temperature Life (preconditioning)	105° C without applied voltage for 72 hours. EIA-364-17, method A	-
6.3.6	Mixed flowing gas	EIA 364-65, Class II A Samples should be placed in an environmentally controlled 'test chamber' that is monitored by a gas analyzing system for controlled concentrations of the specified gas mixture. Test coupons shall also be used and the weight gain reported. Test duration is 7 days.	Contact resistance: 50mΩ max
6.3.7	Thermal disturbance	Cycle the connector or socket between 15 °C ±3 °C and 85 °C ± 3 °C, as measured on the part. Ramps should be a minimum of 2 °C per minute, and dwell times should ensure contacts reach temperature extremes (a minimum of 5 minutes). Humidity is not controlled. Perform 10 such cycles.	Contact resistance: 50mΩ max

PRODUCT SPECIFICATION

Part Number	USB4520	Rev	A1	Date	22/03/23		
Product Description	USB Type C Receptacle for USB 2.0, SMT Type, Mid Mount, 2.0mm Offset			Page	6		
Doc Number	USB Type C	Prepared	CC	Checked	VJ	Approved	PH

7.0 RESISTANCE TO INFRARED REFLOW SOLDERING HEAT

Parameter	Reference	Specification
Average temperature gradient in preheating		2.5°C/s
Soak time	T_{soak}	2-3 minutes
Time above 217°C	T_1	60
Time above 230°C	T_2	50
Time above 250°C	T_3	5
Peak temperature in reflow	T_{peak}	255°C(-0/+5°C)
Temperature gradient in cooling		-5°C/s max

Lead Free Process

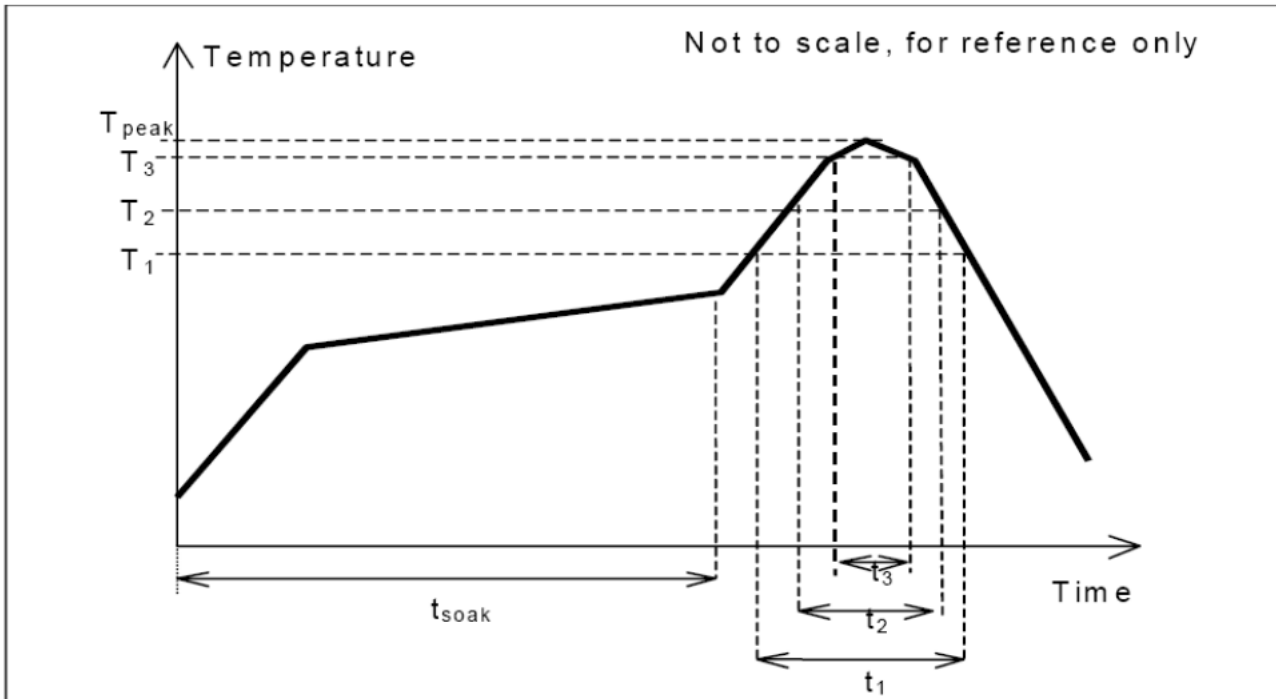

This profile is the minimum requirement for evaluating soldering heat resistance of components. Heat transfer method used for reflow soldering is hot air convection. The actual air temperatures used to achieve the specified profile is higher and largely dependent on the reflow equipment.

PRODUCT SPECIFICATION

Part Number	USB4520	Rev	A1	Date	22/03/23		
Product Description	USB Type C Receptacle for USB 2.0, SMT Type, Mid Mount, 2.0mm Offset			Page	7		
Doc Number	USB Type C	Prepared	CC	Checked	VJ	Approved	PH

8.0 PRODUCT QUALIFICATION AND TEST SEQUENCE

Note: each group test needs 5pcs samples.

Test No	Description	Requirement
Group A-1		
6.0.1	Examination	Visual inspection; No physical damage
6.1.1	LLCR	40mΩ Max all contacts
6.2.2	Durability (preconditioning)	50 cycles; No physical damage
6.3.5	Temperature Life	
6.1.1	LLCR	50mΩ Max all contacts
6.0.1	Reseating	No physical damage
6.1.1	LLCR	50mΩ Max all contacts
6.0.1	Examination	Visual inspection; No physical damage
Group A-2		
6.0.1	Examination	Visual inspection; No physical damage
6.1.1	LLCR	40mΩ Max all contacts
6.2.2	Durability (preconditioning)	50 cycles; No physical damage
6.3.3	Thermal Shock	
6.1.1	LLCR	50mΩ Max all contacts
6.3.1	Humidity	
6.1.1	LLCR	50mΩ Max all contacts
6.0.1	Reseating	No physical damage
6.1.1	LLCR	50mΩ Max all contacts
6.0.1	Examination	Visual inspection; No physical damage
Group A-3		
6.0.1	Examination	Visual inspection; No physical damage
6.1.1	LLCR	40mΩ Max all contacts
6.2.2	Durability (preconditioning)	50 cycles; No physical damage

PRODUCT SPECIFICATION

Part Number	USB4520	Rev	A1	Date	22/03/23		
Product Description	USB Type C Receptacle for USB 2.0, SMT Type, Mid Mount, 2.0mm Offset			Page	8		
Doc Number	USB Type C	Prepared	CC	Checked	VJ	Approved	PH

6.3.5	Temperature Life (preconditioning)	
6.1.1	LLCR	50mΩ Max all contacts
6.2.3	Vibration	Discontinuity less than 1μs
6.1.1	LLCR	50mΩ Max all contacts
6.0.1	Examination	Visual inspection; No physical damage
Group A-4		
6.0.1	Examination	Visual inspection; No physical damage
6.1.1	LLCR	40mΩ Max all contacts
6.2.2	Durability (preconditioning)	50 cycles; No physical damage
6.3.5	Temperature Life (preconditioning)	
6.1.1	LLCR	50mΩ Max all contacts
6.3.6	Mixed Flowing Gases	
6.1.1	LLCR	50mΩ Max all contacts
6.3.7	Thermal Disturbance	
6.1.1	LLCR	50mΩ Max all contacts
6.0.1	Reseating	No physical damage
6.1.1	LLCR	50mΩ Max all contacts
6.0.1	Examination	Visual inspection; No physical damage
Group A-7		
6.0.1	Examination	Visual inspection; No physical damage
6.1.3	DWV	No breakdown or flashover
6.1.1	LLCR	40mΩ Max all contacts
6.2.2	Durability (preconditioning)	No physical damage
6.2.1	Insertion Force	Within the range of 5N to 20N.
6.2.1	Extraction force	Within the range of 8N to 20N. Initial Reading
6.2.2	Durability	25cycles, No physical damage
6.2.1	Extraction force	Within: a) 33% of initial reading & b) 8N to 20N
6.2.2	Durability	Perform 2468cycles and then rotate the plug or socket

PRODUCT SPECIFICATION

Part Number	USB4520	Rev	A1	Date	22/03/23		
Product Description	USB Type C Receptacle for USB 2.0, SMT Type, Mid Mount, 2.0mm Offset			Page	9		
Doc Number	USB Type C	Prepared	CC	Checked	VJ	Approved	PH

			180° and then perform 2500cycles. rotate the plug or socket 180° and then perform 2500cycles. rotate the plug or socket 180° and then perform 2500cycles. No physical damage
6.2.1	Extraction force		Within the range of 6N to 20N.
6.1.1	LLCR		50mΩ Max all contacts
6.1.3	DWV		No breakdown or flashover
6.1.2	Insulation Resistance		100 MΩ Max.
6.0.1	Examination		Visual inspection; No physical damage
Group B-1			
6.0.1	Examination		Visual inspection; No physical damage
6.2.4	4-Axis Continuity		Discontinuity less than 1μs
6.0.1	Examination		Visual inspection; No physical damage
Group B-5			

Test			Common Requirements
Title	EIA 364 Test	Severity or Condition of Test	
Critical Dimensions	18	According to USBIF requirement	All dimensions for component level qualification and overmold only for cable and adaptor assemblies.
EMC Shielding Spring Inspection	n/a	Visual inspection for compliance with Figure 1	No EMC shielding spring finger tip of the USB Full-Featured Type-C plug or USB 2.0 Type-C plug shall be exposed in the plug housing opening of the unmated Type-C plug.

PRODUCT SPECIFICATION

Part Number	USB4520	Rev	A1	Date	22/03/23		
Product Description	USB Type C Receptacle for USB 2.0, SMT Type, Mid Mount, 2.0mm Offset				Page	10	
Doc Number	USB Type C	Prepared	CC	Checked	VJ	Approved	PH

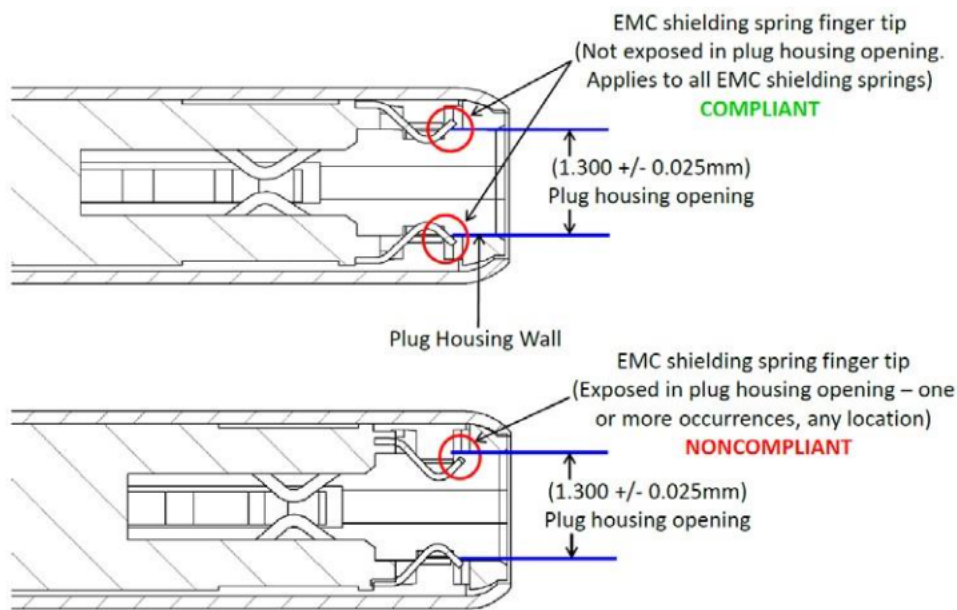

Figure 1 EMC Shielding Spring Tip Requirements

Group B-6		
6.0.1	Examination	Visual inspection; No physical damage
6.1.4	Contact Current Rating	The Temperature Rise shall not exceed 30°C
6.0.1	Examination	Visual inspection; No physical damage

PRODUCT SPECIFICATION

Part Number	USB4520	Rev	A1	Date	22/03/23		
Product Description	USB Type C Receptacle for USB 2.0, SMT Type, Mid Mount, 2.0mm Offset			Page	11		
Doc Number	USB Type C	Prepared	CC	Checked	VJ	Approved	PH

Revision Details:

Revision	Information	Page	Release Date
A	Specification released.	-	26/07/2021
A1	Voltage rating increased to 48Vdc Added power rating	2	22/03/2023