



Product Change Notification / RMES-15BFRM526

Date:

03-May-2023

Product Category:

Wireless IC

PCN Type:

Manufacturing Change

Notification Subject:

CCB 6068 Final Notice: Qualification of STAR as an additional final test site for MICRF219AAYQS, MICRF219AYQS, MICRF220AYQS, MICRF219AAYQS-TR, MICRF219AYQS-TR, MICRF220AYQS-TR, and SPN111001Y-TR catalog part numbers (CPN) available in 16L QSOP (.150in) package.

Affected CPNs:

[RMES-15BFRM526_Affected_CPN_05032023.pdf](#)

[RMES-15BFRM526_Affected_CPN_05032023.csv](#)

Notification Text:

PCN Status:Final Notification

PCN Type:Manufacturing Change

Microchip Parts Affected:Please open one of the files found in the Affected CPNs section.

Note: For your convenience Microchip includes identical files in two formats (.pdf and .xls)

Description of Change:Qualification of STAR as an additional final test site for MICRF219AAYQS, MICRF219AYQS, MICRF220AYQS, MICRF219AAYQS-TR, MICRF219AYQS-TR, MICRF220AYQS-TR, and SPN111001Y-TR catalog part numbers (CPN) available in 16L QSOP (.150in) package.

Pre and Post Change Summary:

	Pre Change	Post Change	
Final Test Site	Unisem (M) Berhad Perak, Malaysia (UNIS)	Unisem (M) Berhad Perak, Malaysia (UNIS)	Stars Microelectronics (Thailand) Public Company Limited (STAR)
Reel BQM	2500	2500	2500
Reel Pin 1 Orientation	Quadrant 1	Quadrant 1	Quadrant 1
Carrier Tape	No change. See pre and post change for comparison.		
Cover Tape	Minor dimension changes. See pre and post change for comparison.		
Sealing Methodology	Heat	Heat	Heat
Plastic Reel	No dimension changes. See pre and post change for comparison.		
Tube BQM	98	98	98
Tube Pin 1 Orientation	Pin 1 toward white stopper	Pin 1 toward white stopper	Pin 1 toward gray stopper
	See pre and post change for comparison.		
Tube Color	Clear Tube	Clear Tube	Clear Tube
Tape and Reel / Tube Packing Method	See pre and post change for comparison.		

Impacts to Data Sheet:None

Change Impact:None

Reason for Change:To improve manufacturability and on-time delivery performance by qualifying STAR as an additional final test site.

Change Implementation Status:In Progress

Estimated First Ship Date:June 05, 2023 (date code: 2323)

Note: Please be advised that after the estimated first ship date customers may receive pre and post change parts.

Time Table Summary:

	March 2023					>	May 2023				June 2023				
Workweek	0	1	1	1	1		1	1	2	2	2	2	2	2	2

	9	0	1	2	3	4	5	6	7	8	9	0	1	2	3	4	5	6
Initial PCN Issue Date			x															
Qual Report Availability										x								
Final PCN Issue Date										x								
Estimated Implementation Date																x		

Method to Identify Change:Traceability code

Qualification Report:Please open the attachments included with this PCN labeled as PCN_#_Qual_Report.

Revision History:March 16, 2023: Issued initial notification.

May 03, 2023: Issued final notification. Attached the Qualification Report. Provided estimated first ship date to be on June 05, 2023.

The change described in this PCN does not alter Microchip’s current regulatory compliance regarding the material content of the applicable products.

Attachments:

[PCN_RMES-15BFRM526_Pre_and_Post_Change_Summary.pdf](#)

[PCN_RMES-15BFRM526_Qual_Report.pdf](#)

Please contact your local [Microchip sales office](#) with questions or concerns regarding this notification.

Terms and Conditions:

If you wish to receive Microchip PCNs via email please register for our PCN email service at our [PCN home page](#) select register then fill in the required fields. You will find instructions about registering for Microchips PCN email service in the [PCN FAQ](#) section.

If you wish to change your PCN profile, including opt out, please go to the [PCN home page](#) select login and sign into your myMicrochip account. Select a profile option from the left navigation bar and make the applicable selections.

RMES-15BFRM526 - CCB 6068 Final Notice: Qualification of STAR as an additional final test site for MICRF219AAYQS, MICRF219AYQS, MICRF220AYQS, MICRF219AAYQS-TR, MICRF219AYQS-TR, MICRF220AYQS-TR, and SPN111001Y-TR catalog part numbers (CPN) available in 16L QSOP (.150in) package.

Affected Catalog Part Numbers (CPN)

MICRF219AAYQS
MICRF219AYQS
MICRF220AYQS
MICRF219AAYQS-TR
MICRF219AYQS-TR
MICRF220AYQS-TR
SPN111001Y-TR



MICROCHIP

QUALIFICATION REPORT SUMMARY

PCN #: RMES-15BFRM526

Date

April 21, 2023

**Qualification of STAR as an additional final test site for
MICRF219AAYQS, MICRF219AYQS, MICRF220AYQS,
MICRF219AAYQS-TR, MICRF219AYQS-TR, MICRF220AYQS-TR,
and SPN111001Y-TR catalog part numbers (CPN) available in
16L QSOP (.150in) package.**

Purpose: Qualification of STAR as an additional final test site for MICRF219AAYQS, MICRF219AYQS, MICRF220AYQS, MICRF219AAYQS-TR, MICRF219AYQS-TR, MICRF220AYQS-TR, and SPN111001Y-TR catalog part numbers (CPN) available in 16L QSOP (.150in) package.

CCB No.: 6068

Test Name	Test Conditions	Sample Size	Qty of Lots	Fail/Accept Criteria	Results
Bin and Yield Comparison	Test the same units at existing and destination locations and compare BIN and Yield data.	3000	1	≤0.1%	PASSED
Parametric / Characterization Comparison	Characterize the same units at existing and destination locations and compare data.	33	1	≤10%	PASSED
Test flow	Final Test Room 100% -> QA Sample Room.	3000	1	1% LTPD	PASSED

CCB 6068
Pre and Post Change Summary
PCN #: RMES-15BFRM526



A Leading Provider of Smart, Connected and Secure Embedded Control Solutions

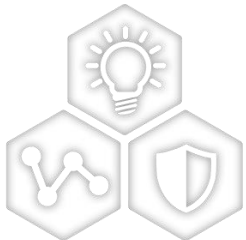

SMART | CONNECTED | SECURE

Pre and Post Change – Tape and Reel

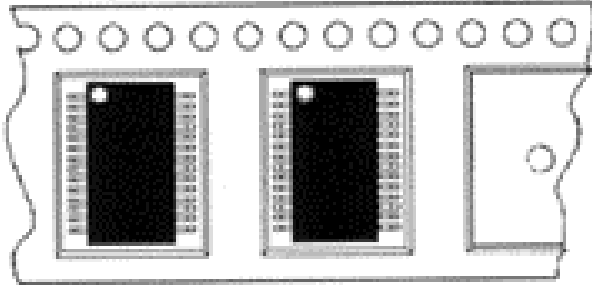
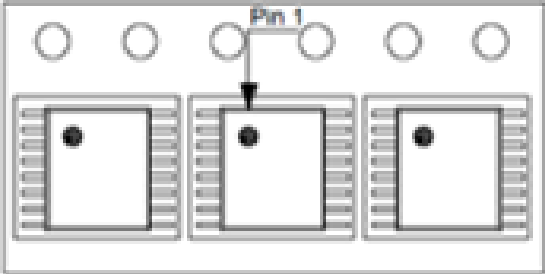
	UNIS	STAR
BQM (Base Quantity Multiple)	2500 per reel	2500 per reel
Pin 1 orientation	 <p>Quadrant 1</p>	 <p>Quadrant 1</p>

Pre and Post Change – Plastic Reel

UNIS

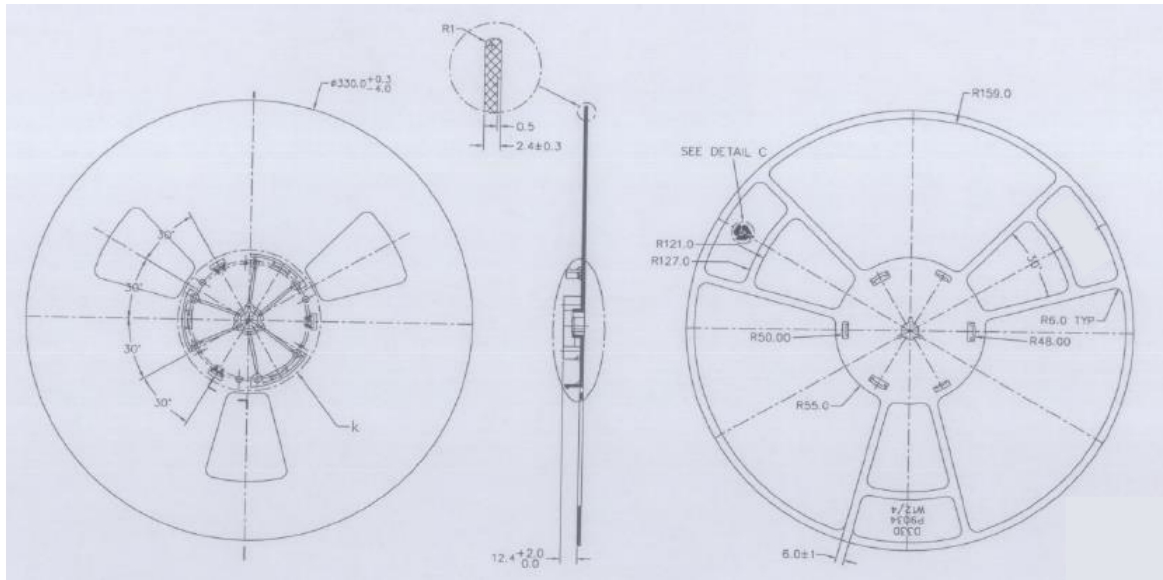

- NOTES:
- UNLESS OTHERWISE SPECIFIED
 - MATERIAL: POLYSTYRENE(BLUE)
 - ANTISTATIC COATED
 - FLANGE WARPAGE : 3 MM MAXIMUM
 - ALL DIMENSIONS ARE IN MM
 - ESD – SURFACE RESISTIVITY
– 10^8 TO 10^{11} OHMS/50
 - GENERAL TOLERANCE : –X.X=±0.4, –X.XX=±0.20
 - TOTAL THICKNESS OF REEL: 18.4 MAX
 - PART NO: P9034

STAR

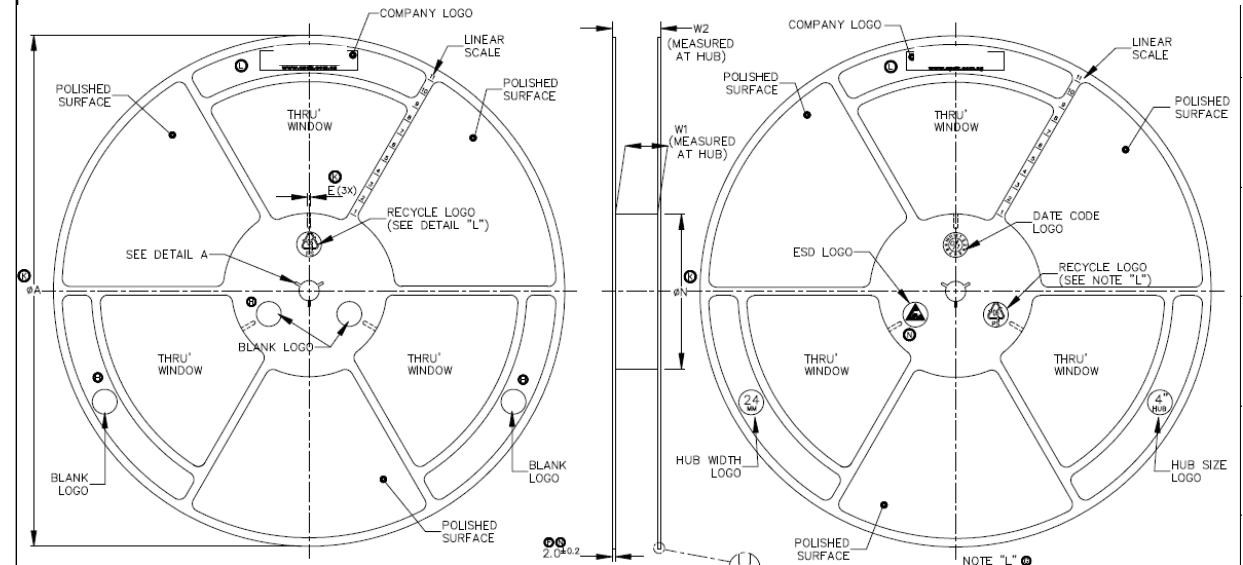

TAPE WIDTH	SR RANGE		W1	W2 (MAX)	E (MIN)
	#A ±2.0	#N ±2.0			
08MM	330	100	8.4 ± 0.2	14.4	2.5
12MM	330	100	12.4 ± 0.2	18.4	2.5
16MM	330	100	16.4 ± 0.2	22.4	2.5
24MM	330	100	24.4 ± 0.2	30.4	2.5
32MM	330	100	32.4 ± 0.2	38.4	2.5

LEGEND	SR RANGE		TYPE	COLOUR
	A	B		
A	BELOW 10^{12}		ANTISTATIC	ALL TYPES
B	10^9 TO 10^{11}		STATIC DISSIPATIVE	BLACK ONLY
C	10^2 & BELOW 10^9		CONDUCTIVE (GENERIC)	BLACK ONLY
C	10^2 TO 10^9		CONDUCTIVE (CUSTOM)	BLACK ONLY
E	BELOW 10^{12}		COATED ANTISTATIC	ALL COLOR

- NOTE:
- GENERIC PRODUCT
 - FOR PRODUCT DRAWING ONLY.
 - SANDBLAST ALL SURFACE UNLESS OTHERWISE STATED.
 - MOLD 2
- ① TITLE : 13X4 WELDED REEL
- | | | | |
|---------|------------|-------------|------------|
| S.R. # | TOL. NO. | PT20420983 | POI |
| SCALE : | NTS | SHRINKAGE : | 0.45% |
| REV. : | MATERIAL : | PS | X.XX ±0.25 |
| UNIT : | WARPAGE : | | X.XX ±0.13 |
| SHT : | NAME : | | DATE : |
| DRAWN : | AFIZAH | 150605 | X ±30° |
| CHECK : | SHUKRI | 150605 | X.X ±15° |

Note: No change in dimension and appearance.

Pre and Post Change – Carrier Tape

UNIS

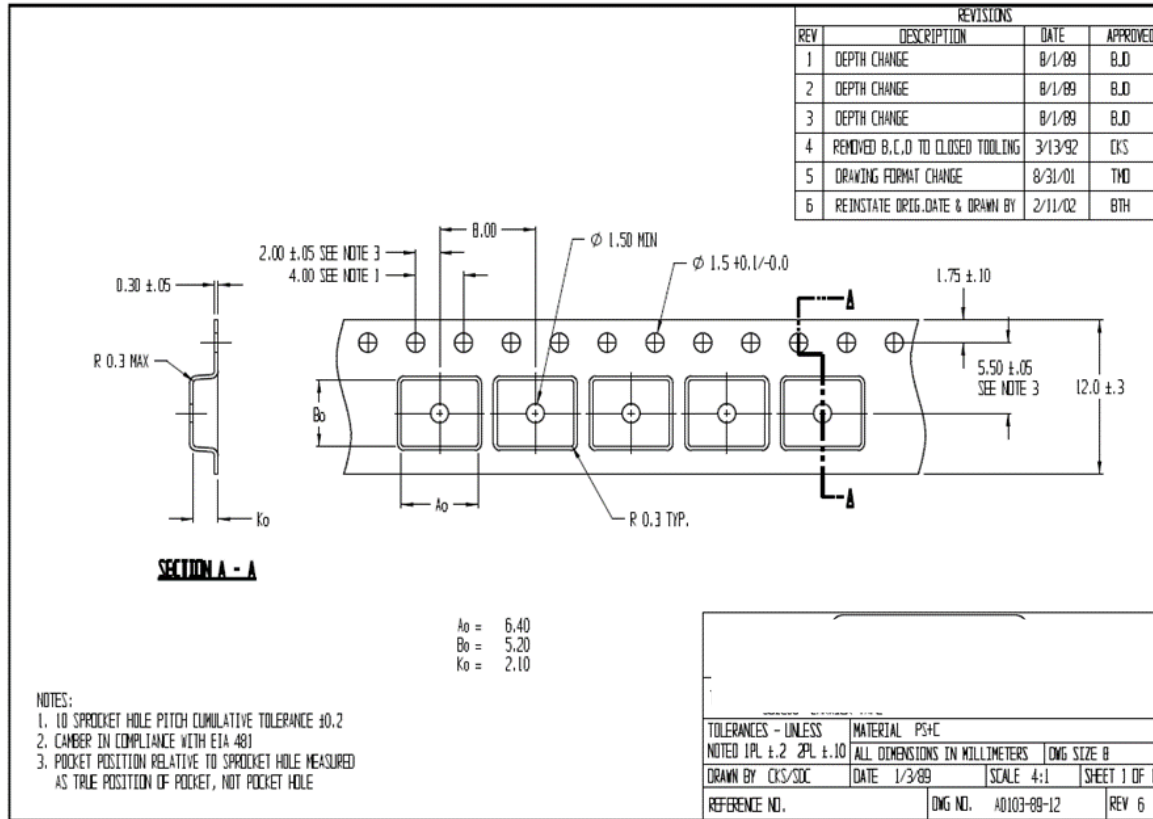

STAR

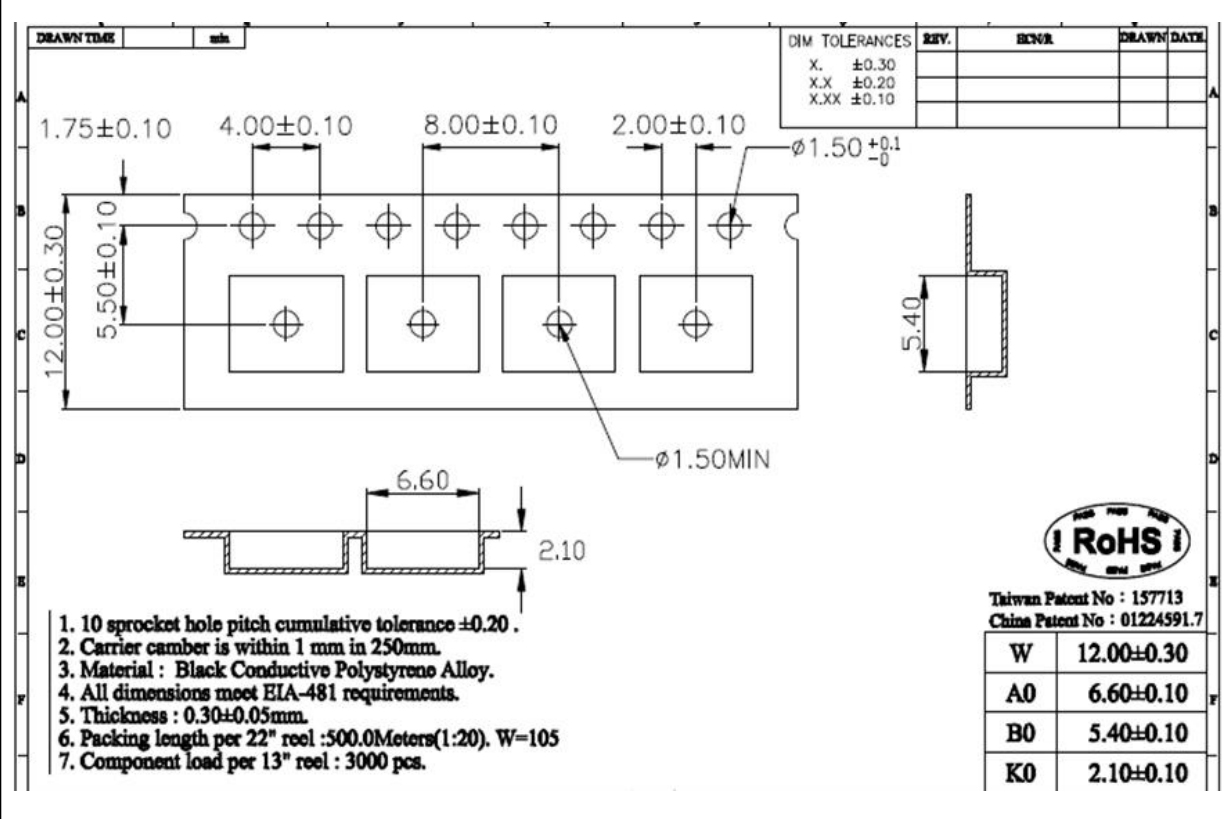

Plant	W (mm.) ± 0.3 or Specific	P (mm.) ± 0.1 or Specific	A ₀ ± 0.1 or Specific	B ₀ ± 0.1 or Specific	K ₀ ± 0.1 or Specific
UNIS	12	8	6.40	5.20	2.10
STAR	12	8	6.60	5.40	2.10

Pre and Post Change – Cover Tape

UNIS

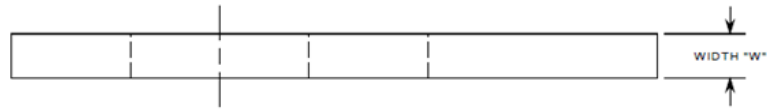

76.2 (3.0 INCHES) NOMINAL INSIDE CORE DIAMETER

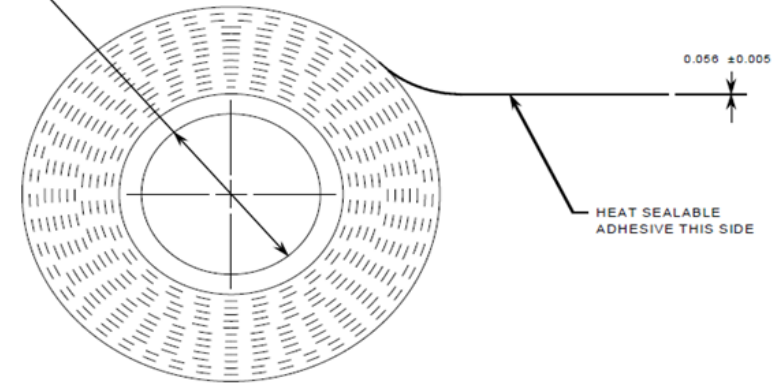

HEAT SEALABLE ADHESIVE THIS SIDE

REVISIONS			
No.	ECO Number	Date	By
2	SEE A1111-93-2 REV. 2		
3	A10076	4/2/98	T.S.
4	A10076	3/24/98	T.S.
5	A-10134	3/11/99	T.S.

PART NO.	WIDTH "W"
AA05305NP	5.3±0.1mm
AA05405NP	5.4±0.1mm
AA09205NP	9.2±0.1mm
AA09505NP	9.5±0.1mm
AA13105NP	13.1±0.1mm
AA13305NP	13.3±0.1mm
AA13405NP	13.4±0.1mm
AA21005NP	21.0±0.1mm
AA21305NP	21.3±0.1mm
AA25505NP	25.5±0.1mm
AA37505NP	37.5±0.1mm
AA49505NP	49.5±0.1mm
AA65505NP	65.5±0.15mm
AA81505NP	81.5±0.15mm
AA97505NP	97.5±0.20mm
AA11355NP	113.5±0.20mm
AA12955NP	129.5±0.25mm
AA14555NP	145.5±0.25mm
AA16155NP	161.5±0.30mm
AA17755NP	177.5±0.30mm
AA19355NP	193.5±0.30mm

- All Dimensions in Millimeters -

NOTE:

1. REEL TO CONTAIN 300 METERS OF SPLICE FREE MATERIAL.
2. MATERIAL: ANTISTATIC POLYESTER FILM.
3. COLOR: TRANSPARENT, PALE BLUE.
4. THESE WIDTHS ARE ALSO AVAILABLE IN 500 METER LENGTHS.

STAR

Cover Tape Certificate of Conformance

Primary ESD Function: Antistatic
 Item Number: 15280052H
 Description: CP230-092A L300 /
 Width (mm): 9.20 mm
 Lot Number: H806387-42
 Manufacturing Date: 26 Apr 2021
 Expiry Date: 26 Apr 2023
 Inspector: 5201



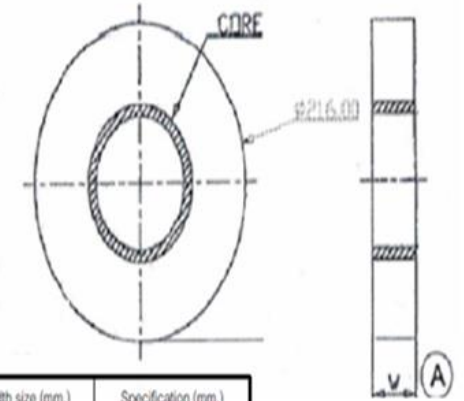



Specification	Maximum	Minimum	Average	
Width (mm)	9.20 +/- 0.10 mm	9.23 mm	9.16 mm	9.20 mm
Thickness (mm)	0.056 +/- 0.005 mm	0.053 mm	0.053 mm	0.053 mm
Top Surface Resistivity	1.0E+9 to 9.9E+10 ohms/sq	4.4E+9 ohms/sq	4.1E+9 ohms/sq	4.3E+9 ohms/sq
Adhesive Surface Resistivity	1.0E+9 to 9.9E+10 ohms/sq	3.8E+9 ohms/sq	3.1E+9 ohms/sq	3.5E+9 ohms/sq
Peel Strength	55 +/- 15 grams	49.0 grams	47.0 grams	48.0 grams
Haze	75% Max	57.2	57.1	57.15



Width size (mm.)	Specification (mm.)
5.3	5.2 - 5.4
9.2	9.1 - 9.3
13.3	13.2 - 13.4

Plant	Carrier Tape Width	Cover Tape Width	Thickness	Color	Sealing mythology
UNIS	16mm	13.3 +/-0.1mm	0.056+/-0.005	Clear	Heat sealing
STAR	16mm	13.3 +/-0.2mm	0.050+/-0.005	Clear	Heat sealing



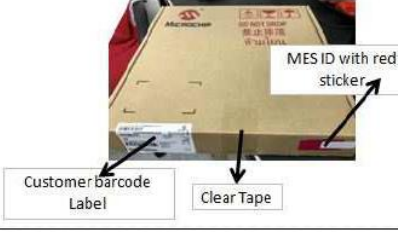

Pre and Post Change – Tape and Reel Packing Method

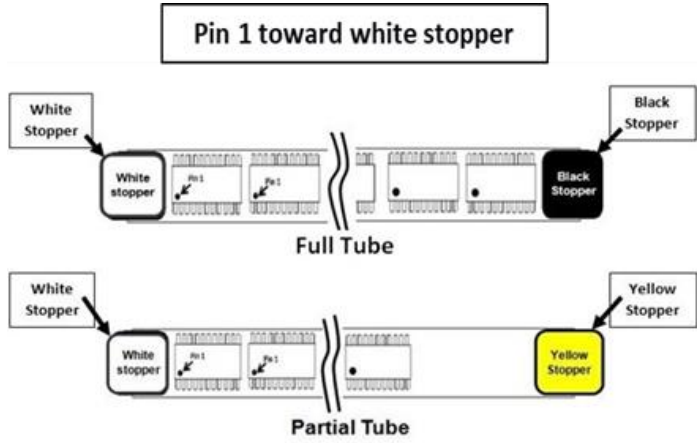
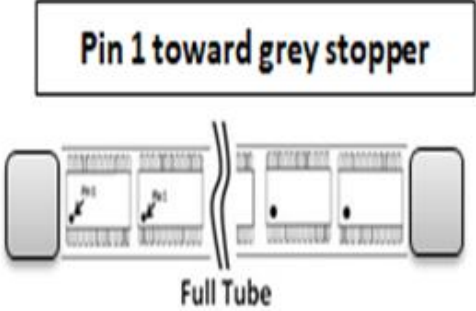
UNIS	STAR
 <p>Microchip Barcode label</p> <ol style="list-style-type: none"> 1) 13" Blue Reel - D330-P9034-W12/4 (P/N: 47370032) 2) Microchip Barcode label (P/N: 50320185) 3) 12mm Protective band (P/N: 47560001) 	
<div style="display: flex; justify-content: space-around;"> <div style="text-align: center;"> <p>Front</p>  <p>ESD LOGO Customer Barcode Label</p> </div> <div style="text-align: center;"> <p>Back</p>  <p>Adhesive ESD tape</p> </div> </div> <ol style="list-style-type: none"> 1) Static Shield Bag 16"X16" (P/N: 50020046) 2) Microchip Standard Barcode Label (P/N:50320185) at below ESD Logo <p>Back:</p> <ol style="list-style-type: none"> 1)Seal Antistatic shield bag with adhesive ESD tape. 	 <p>Packing in Reel 13 Inch → Insert Reel in static shielding ba → Packing in box → Put label</p>
<div style="display: flex; justify-content: space-around;"> <div style="text-align: center;">  <p>ESD LOGO Customer Barcode Label</p> </div> <div style="text-align: center;">  <p>Antistatic Bubble bag</p> </div> </div> <ol style="list-style-type: none"> 1)Quantity/box = 1 reel 2) Use antistatic bubble bag sheet fill in the space if much space inside the box 	
 <p>Customer Barcode Label Clear Tape MES ID with red sticker</p> <ol style="list-style-type: none"> 1) Microchip Box = M02-009 Brown-Pizza-13" (P/N: 50080187) 2) Microchip Standard Barcode Label (P/N:50320185) at left side of box opening 3) Red sticker with MES ID at right side of box opening 4) Seal box opening with clear tape at the middle <p>(Note: Remove red sticker with MES ID before ship to customer)</p>	

Pre and Post Change – Tube

	UNIS	STAR
BQM (Base Quantity Multiple)	98 units	98 units
Pin 1 orientation	<p>Pin 1 toward white stopper</p> 	<p>Pin 1 toward grey stopper</p> 
Tube Color	Clear tube	Clear tube
Plug Color	Full Tube: White – Black Partial Tube: White – Yellow	Grey-Grey

Pre and Post Change – Tube Packing Method

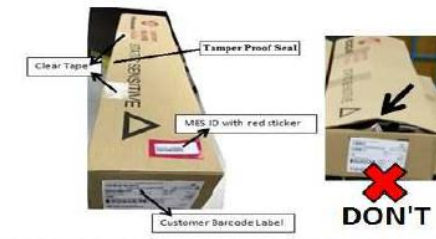
UNIS	STAR
 <p>Meratakan sebelum balut bubble bag</p>	
 <p>Customer Barcode Label</p> <p>Front</p> <p>ESD 1090</p> <p>Back</p> <p>ESD adhesive tape</p>	 <p>Packing units in tube</p> <p>Insert Tube in ESD bag</p> <p>Insert bag in inner box</p>
	
 <p>Clear Tape</p> <p>Tamper Proof Seal</p> <p>MES ID with red sticker</p> <p>Customer Barcode Label</p> <p>DON'T</p>	

- 1) 1 Bundle = Max 150 Tubes
 - 2) Bubble bag sheet wrap on both end side of tube and seal with adhesive ESD tape
- Note: Meratakan tube sebelum balut bubble bag.

- 1) Antistatic Shield Bag 12"X32" (P/N: 50020053)
- 2) 1 Bag = 1 bundle = Max 150 Tubes
- 3) Microchip Barcode Label (P/N: 50320185) on front of Antistatic Shield Bag
- 4) Seal the excess Antistatic shield bag with ESD adhesive tape at the back

- 1) Microchip Box = M02-011 Big Tube Inner" Brown (P/N: 50080188)
- 2) 1 box = Max 1 bag
- 3) Use anti-static bubble bag sheet to fill the space if much space inside the box

- 1) Microchip Barcode Label (P/N: 50320185) at the right side of box
 - 2) Seal the box opening with 2 x clear tapes
 - 3) Tamper-Proof Seal at the middle of box opening
- (Note: Remove MES ID with red sticker before ship to customer)