



# MP2720A

## 2.2A, Single-Cell, I<sup>2</sup>C-Controlled Buck Charger with 15mA Termination Current

### DESCRIPTION

The MP2720A is a highly integrated, 2.2A switch-mode battery management device for single-cell Li-ion or Li-polymer batteries. The narrow-voltage DC (NVDC) power management structure provides a low impedance power path that charging efficiency, reduces battery charging time, and extends battery life during discharging.

The device's input source type identification algorithm supports USB battery charging specification 1.2 (BC1.2) and non-standard adapter detection.

The I<sup>2</sup>C interface offers complete operating control, including charging parameter configurations and status/interrupt monitoring.

The MP2720A supports a fully customizable JEITA profile with configurable temperature windows and actions.

The MP2720A is available in a QFN-22 (2.5mmx3.5mm) package.

### FEATURES

- 2.2A Switching Charger with Narrow-Voltage DC (NVDC) Power Path Management
- Supports USB BC1.2 and Non-Standard Adapters
- 26V Sustainable Input Voltage ( $V_{IN}$ )
- Configurable 40mA to 2.2A Charge Current ( $I_{CC}$ ) via I<sup>2</sup>C
- Configurable 100mA to 3.2A Input Current Limit ( $I_{IN\_LIM}$ ) via I<sup>2</sup>C
- Minimum  $V_{IN}$  Loop for Maximum Adapter Power Tracking
- Comprehensive Safety Features:
  - Fully Customizable JEITA Profile
  - Additional Negative Temperature Coefficient (NTC) Thermistor Input
  - Configurable Die Temperature Regulation from 60°C to 120°C

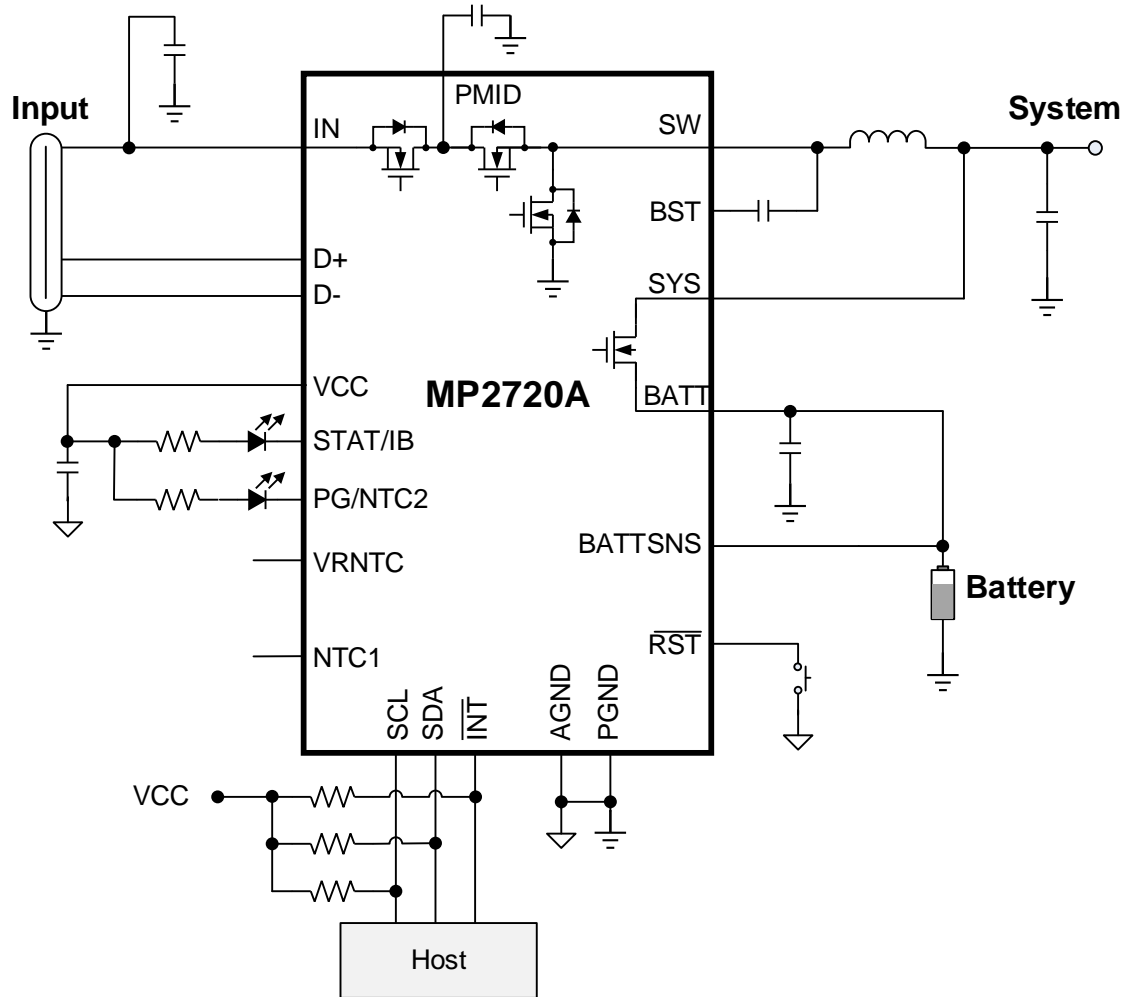
- Complete Charge and Pre-Charge Safety Timers
- Watchdog Safety Timer
- Lockable Registers for Charging Parameters
- Configurable 750kHz to 1.5MHz Switching Frequency ( $f_{sw}$ )
- Integrated 30mΩ Low- $R_{DS(ON)}$  Battery MOSFET with Shipping and Reset Modes
- Ultra-Low 8.5μA Battery Discharge Current in Shipping Mode
- Down to 15mA Termination Current Settings for Wearable Applications
- I<sup>2</sup>C Port for Flexible System Parameter Setting and Status Reporting
- Configurable Boost Converter for Source Mode and USB On-The-Go (OTG):
  - Configurable Output Current Limit Loop Up to 3A
  - Output Over-Current Protection (OCP)
  - Ability to Power into Large Capacitive Loads Up to 2mF
  - Configurable 5V to 5.35V Output Voltage
- Accuracy:
  - ±0.5% Battery Regulation Voltage ( $V_{BATT\_REG}$ )
  - ±5%  $I_{CC}$
  - ±5%  $I_{IN\_LIM}$
  - Remote Battery Sensing for Fast Charge
  - ±2% Output Regulation in Boost Mode
- Available in a Small QFN-22(2.5mmx3.5mm) Package

### APPLICATIONS

- General ≤15W USB Applications
- Bluetooth Headphones
- Bluetooth Speakers
- Point-of-Sale (POS) Terminals
- Portable Cameras

All MPS parts are lead-free, halogen-free, and adhere to the RoHS directive. For MPS green status, please visit the MPS website under Quality Assurance. "MPS", the MPS logo, and "Simple, Easy Solutions" are trademarks of Monolithic Power Systems, Inc. or its subsidiaries.

### TYPICAL APPLICATION



### ORDERING INFORMATION

Part Number*	Package	Top Marking	MSL Rating
MP2720AGRH-xxxx**	QFN-22 (2.5mmx3.5mm)	See Below	1
EVKT-MP2720A	Evaluation Kit	-	-

\* For Tape & Reel, add suffix -Z (e.g. MP2720AGRH-xxxx-Z).

\*\* “xxxx” is the register setting option. The factory default code is “0000”. This content can be viewed in the I<sup>2</sup>C register map. Contact an MPS FAE to obtain an “xxxx” value.

### TOP MARKING

**BZF**

**YWW**

**LLL**

BZF: Product code  
 Y: Year code  
 WW: Week code  
 LLL: Lot number

### EVALUATION KIT EVKT-MP2720A

EVKT-MP2720A kit contents (items below can be ordered separately):

#	Part Number	Item	Quantity
1	EV2720A-RH-00A	MP2720A evaluation board	1
2	EVKT-USBI2C-02-BAG	Includes one USB to I <sup>2</sup> C communication interface device, one USB cable, and one ribbon cable	1
3	Online resources	Include the datasheet, user guide, product brief, and GUI	1

Order directly from [MonolithicPower.com](http://MonolithicPower.com) or our distributors.

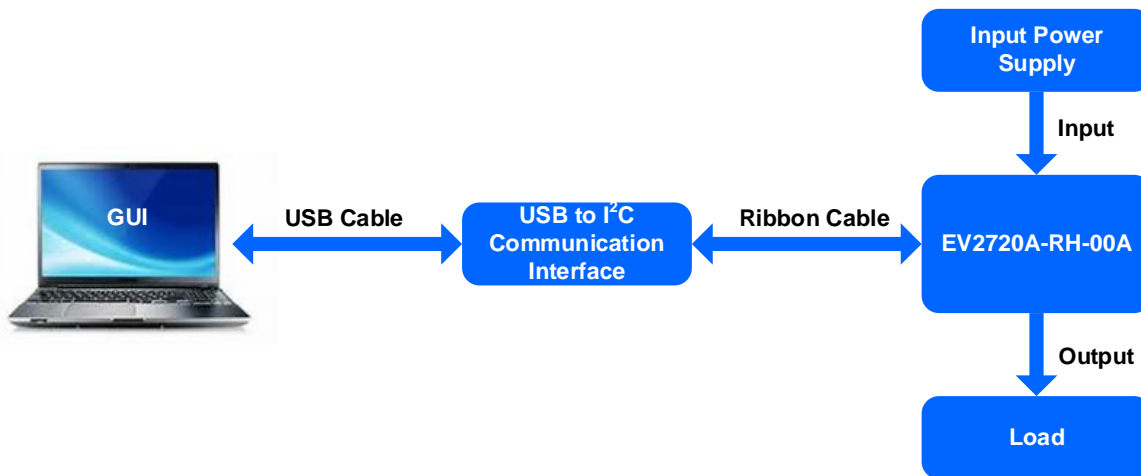
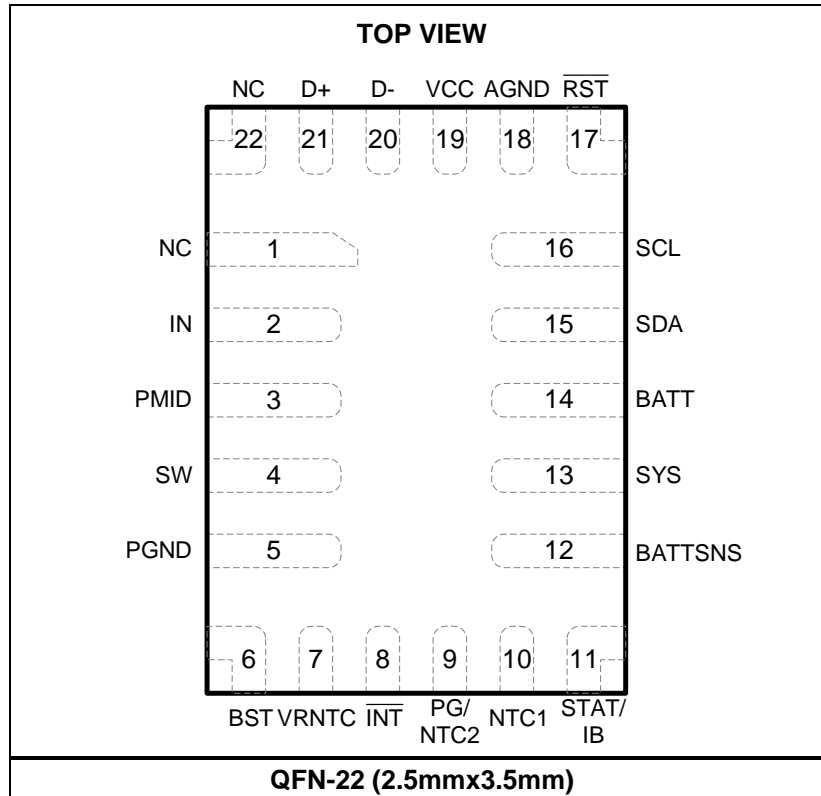


Figure 1: EVKT-MP2720A Evaluation Kit Set-Up

### PACKAGE REFERENCE



**PIN FUNCTIONS**

Pin #	Name	Type <sup>(1)</sup>	Description
2	IN	P	<b>Power input.</b> Connect a 1 $\mu$ F ceramic capacitor from the IN pin to PGND.
3	PMID	P	<b>Decoupling node for the power stage.</b> Bypass the PMID pin with a minimum 10 $\mu$ F ceramic capacitor connected from PMID to PGND, and placed as close to the IC as possible with the shortest possible route.
4	SW	P	<b>Switching node.</b> Connect the SW pin to the inductor.
6	BST	P	<b>Bootstrap power.</b> Connect a 22nF capacitor between the BST and SW pins to form a floating supply for the high-side MOSFET (HS-FET) driver.
13	SYS	P	<b>System power output.</b> Connect a minimum 20 $\mu$ F ceramic capacitor from the SYS pin to PGND.
14	BATT	P	<b>Battery positive terminal.</b> The internal narrow-voltage DC (NVDC) battery MOSFET is connected between the SYS and BATT pins. Place a minimum 20 $\mu$ F ceramic capacitor from BATT to PGND.
5	PGND	P	<b>Power ground.</b> Short the PGND pin to AGND on the PCB.
18	AGND	P	<b>Analog ground.</b> Short the AGND pin to PGND on the PCB.
19	VCC	P	<b>Internal circuit power supply.</b> Connect a 4.7 $\mu$ F ceramic capacitor from the VCC pin to AGND, placed as close to the IC as possible.
12	BATTSNS	AI	<b>Battery voltage-sense pin for battery voltage regulation.</b> Connect the BATTSNS pin as close as possible to the battery pack's positive terminal.
8	INT	DO	<b>Open-drain interrupt output.</b> This pin generates an active low 256 $\mu$ s pulse when the IC has a status or fault report. Pull this pin up to VCC or another logic rail with a 10k $\Omega$ resistor.
16	SCL	DI	<b>I<sup>2</sup>C interface clock.</b> Pull the SCL pin up to VCC or another logic rail with a 10k $\Omega$ resistor.
15	SDA	DIO	<b>I<sup>2</sup>C interface data.</b> Pull the SDA pin up to VCC or another logic rail with a 10k $\Omega$ resistor.
1, 22	NC	-	<b>No connection.</b> The NC pin can be left open or shorted to AGND.
21	D+	AIO	<b>Positive line of the USB data line pair.</b> USB charger type detection is based on BC1.2. Non-standard adapter detection can also be implemented.
20	D-	AIO	<b>Negative line of the USB data line pair.</b> USB charger type detection is based on BC1.2. Non-standard adapter detection can also be implemented.
17	RST	DI	<b>Battery MOSFET reset input.</b> During shipping mode, pull this pin to logic low for a set time ( $t_{SHIPMODE}$ ) to wake up the IC from shipping mode. When the input voltage ( $V_{IN}$ ) is not present, setting this pin to logic low for a set time ( $t_{RST}$ ) resets the SYS power by turning the battery MOSFET off for a set time ( $t_{SYS\_RST}$ ). Then the battery MOSFET is re-enabled. This pin is internally pulled up by a 200k $\Omega$ resistor. Float this pin if it is not used.
7	VRNTC	AO	<b>Voltage output for powering up the NTC.</b> The VRNTC pin is powered up to the same voltage as VCC when the buck or boost converter operates.
10	NTC1	AI	<b>Temperature-sense input 1.</b> Connect the NTC1 pin to a negative temperature coefficient (NTC) thermistor. Connect a resistor divider from VRNTC to NTC1 to AGND. NTC1 supports a JEITA profile.
9	PG/NTC2	DO/AI	<b>Open-drain power good indicator.</b> Pull the PG/NTC2 pin up with a 10k $\Omega$ resistor. This pin is active low when the VIN_GD bit is 1, and it can be configured to act as temperature-sense input 2.

**PIN FUNCTIONS (continued)**

Pin #	Name	Type <sup>(1)</sup>	Description
11	STAT/IB	DO/AO	<b>Charge status open-drain output.</b> Pull the STAT/IB pin up with a 10kΩ resistor. This pin goes low to indicate when charging is in progress; it goes high to indicate when charging is complete or not in progress. It blinks at a frequency of 1Hz if a fault occurs. This pin can also be configured for battery current indication (IB). The IB pin sources a current that is proportional to the battery's charge or discharge current. Connect a resistor from IB to AGND for the battery current information.

**Notes:**

- 1) AI = analog input, AO = analog output, AIO = analog input output, DI = digital input, DO = digital output, DIO = digital input output, P = power.

**ABSOLUTE MAXIMUM RATINGS <sup>(2)</sup>**

IN to PGND .....	-0.3V to +26V
PMID to PGND .....	-0.3V to +26V
SW to PGND.....	-0.3V (-2V for 20ns) to +24V
PMID to IN .....	-0.3V to +12V
BATT, SYS to PGND .....	-0.3V to +6.5V
BST to SW.....	-0.3V to +5V
All Other Pins to AGND.....	-0.3V to +5V
Continuous power dissipation (T <sub>A</sub> = 25°C) <sup>(3)</sup>	..... 2W
Junction temperature .....	150°C
Lead temperature (solder) .....	260°C
Storage temperature .....	-65°C to +150°C

**ESD Ratings**

Human body model (HBM) <sup>(4)</sup> .....	2000V
Charged device model (CDM) <sup>(5)</sup> .....	250V

**Recommended Operating Conditions <sup>(7)</sup>**

Supply voltage (V <sub>IN</sub> ) .....	3.9V to 6.3V
Input current (I <sub>IN</sub> ) .....	Up to 3.2A
System current (I <sub>SYS</sub> ).....	Up to 5A
Charge current (I <sub>CC</sub> ) .....	Up to 2.2A
Discharge current (I <sub>DISCHG</sub> ) .....	Up to 4A
Battery voltage (V <sub>BATT</sub> ) .....	Up to 4.6V
Operating junction temp (T <sub>J</sub> )....	-40°C to +125°C

**Thermal Resistance <sup>(6)</sup> θ<sub>JA</sub> θ<sub>JC</sub>**

QFN-22 (2.5mmx3.5mm).....	50	12	°C/W
---------------------------	----	----	------

**Notes:**

- 2) Exceeding these ratings may damage the device.  
3) The maximum allowable power dissipation is a function of the maximum junction temperature, T<sub>J</sub> (MAX), the junction-to-ambient thermal resistance, θ<sub>JA</sub>, and the ambient temperature, T<sub>A</sub>. The maximum allowable continuous power dissipation at any ambient temperature is calculated by P<sub>D</sub> (MAX) = (T<sub>J</sub> (MAX) - T<sub>A</sub>) / θ<sub>JA</sub>. Exceeding the maximum allowable power dissipation can cause excessive die temperature, and the regulator may go into thermal shutdown. Internal thermal shutdown circuitry protects the device from permanent damage.  
4) Per ANSI/ESDA/JEDEC JS-001, all pins.  
5) Per ANSI/ESDA/JEDEC JS-002, all pins.  
6) Measured on JESD51-7, 4-layer PCB.  
7) The device is not guaranteed to function outside of its operating conditions.

## ELECTRICAL CHARACTERISTICS

T<sub>A</sub> = -40°C to +125°C, T<sub>A</sub> = 25°C, and V<sub>BATT</sub> = 4V for typical values, unless otherwise noted.

Parameters	Symbol	Condition	Min	Typ	Max	Units
<b>Quiescent Current</b>						
Battery discharge current in shipping mode	I <sub>BATT_SHIP</sub>	V <sub>BATT</sub> = 4V, V <sub>IN</sub> = 0V, BATTFET disabled, T <sub>A</sub> = -40°C to +85°C		8.5	12	μA
Battery discharge current in idle mode	I <sub>BATT_IDLE</sub>	V <sub>BATT</sub> = 4V, V <sub>IN</sub> = 0V, BATTFET enabled, T <sub>A</sub> = -40°C to +85°C		44	64	μA
USB suspend mode current	I <sub>IN_SUSP</sub>	V <sub>IN</sub> = 5V, EN_BUCK = 0		0.8		mA
<b>Power-On/Off</b>						
Input operating range	V <sub>IN_OP</sub>		3.9		6.3	V
Input under-voltage lockout (UVLO) threshold	V <sub>IN_UV</sub>	V <sub>IN</sub> falling, V <sub>BATT</sub> = 0V	3.1	3.25	3.45	V
Input UVLO threshold hysteresis	V <sub>IN_UV_HYS</sub>	V <sub>IN</sub> rising, V <sub>BATT</sub> = 0V		250		mV
Input debounce time	t <sub>DEB</sub>	V <sub>IN</sub> debounce to set VIN_GD		15		ms
Hold-off timer	t <sub>HOLD</sub>	VIN_GD = 1 to D+ and D- detection starts		250		ms
Input vs. battery voltage headroom threshold	V <sub>HDRM</sub>	V <sub>IN</sub> - V <sub>BATT</sub> , V <sub>BATT</sub> = 4V, V <sub>IN</sub> rising	135	240	340	mV
		V <sub>IN</sub> - V <sub>BATT</sub> , V <sub>BATT</sub> = 4V, V <sub>IN</sub> falling	10	80	175	mV
Input over-voltage protection (OVP) threshold	V <sub>IN_OV</sub>	V <sub>IN</sub> rising	6.1	6.3	6.55	V
Input OVP hysteresis	V <sub>IN_OV_HYS</sub>	V <sub>IN</sub> falling		250		mV
BATT UVLO threshold	V <sub>BATT_UV</sub>	V <sub>IN</sub> = 0, V <sub>BATT</sub> falling	2.4	2.5	2.6	V
BATT UVLO hysteresis	V <sub>BATT_UV_HYS</sub>	V <sub>IN</sub> = 0, V <sub>BATT</sub> rising		400		mV
<b>Power Path</b>						
System regulation voltage	V <sub>SYS_REG</sub>	V <sub>BATT</sub> < V <sub>SYS_MIN</sub> , SYS_MIN = 100	3.7	3.82	3.94	V
Blocking FET on resistance	R <sub>ON_RBFET</sub>	T <sub>A</sub> = 25°C		15		mΩ
High-side MOSFET (HS-FET) on resistance	R <sub>ON_HS</sub>	T <sub>A</sub> = 25°C		25		mΩ
Low-side MOSFET (LS-FET) on resistance	R <sub>ON_LS</sub>	T <sub>A</sub> = 25°C		25		mΩ
Battery MOSFET on resistance	R <sub>ON_BFET</sub>	T <sub>A</sub> = 25°C		30		mΩ
Battery MOSFET forward voltage in supplement mode	V <sub>FWD</sub>			30		mV
<b>Charge (T<sub>A</sub> = 0°C to 70°C)</b>						
Charge voltage configuration range	V <sub>BATT_RANGE</sub>		3.6		4.6	V
Charge voltage step	V <sub>BATT_STEP</sub>			25		mV
Battery charge voltage regulation	V <sub>BATT_REG</sub>	V <sub>BATT</sub> = 4.2V	4.179	4.200	4.221	V
		V <sub>BATT</sub> = 4.35V	4.328	4.350	4.372	V
Charge current regulation range	I <sub>CC_RANGE</sub>		0		2200	mA
Charge current step	I <sub>CC_STEP</sub>			40		mA
Fast charge current	I <sub>CC</sub>	I <sub>CC</sub> = 520mA, V <sub>BATT</sub> = 3.8V	0.46	0.52	0.58	A
		I <sub>CC</sub> = 1000mA, V <sub>BATT</sub> = 3.8V	0.95	1	1.05	A

**ELECTRICAL CHARACTERISTICS (continued)**
**T<sub>A</sub> = -40°C to +125°C, T<sub>A</sub> = 25°C, and V<sub>BATT</sub> = 4V for typical values, unless otherwise noted.**

Parameters	Symbol	Condition	Min	Typ	Max	Units
Pre-charge to fast charge threshold	V <sub>BATT_PRE</sub>	V <sub>BATT</sub> rising, V <sub>PRE</sub> = 3.2V	3.1	3.2	3.3	V
Pre-charge to fast charge threshold hysteresis		V <sub>BATT</sub> falling, V <sub>PRE</sub> = 3.2V		250		mV
Pre-charge current	I <sub>PRE</sub>	I <sub>PRE</sub> = 20mA, V <sub>BATT</sub> = 2.5V, T <sub>A</sub> = 25°C	13	20	28	mA
		I <sub>PRE</sub> = 20mA, V <sub>BATT</sub> = 2.5V	10	20	32	mA
		I <sub>PRE</sub> = 40mA, V <sub>BATT</sub> = 2.5V	31	40	50	mA
		I <sub>PRE</sub> = 120mA, V <sub>BATT</sub> = 2.5V	102	120	142	mA
Charge termination current threshold	I <sub>TERM</sub>	I <sub>TERM</sub> = 15mA, T <sub>A</sub> = 25°C	10	15	22	mA
		I <sub>TERM</sub> = 15mA	9	15	23	mA
		I <sub>TERM</sub> = 30mA	21	30	41	mA
		I <sub>TERM</sub> = 135mA	102	135	168	mA
Trickle charge to pre-charge threshold	V <sub>BATT_TC</sub>	V <sub>BATT</sub> rising	1.9	2	2.1	V
Trickle charge to pre-charge threshold hysteresis		V <sub>BATT</sub> falling		200		mV
Trickle charge current	I <sub>TC</sub>	I <sub>TRICKLE</sub> = 16mA, V <sub>BATT</sub> = 1V, T <sub>A</sub> = 25°C	10	16	25	mA
		I <sub>TRICKLE</sub> = 16mA, V <sub>BATT</sub> = 1V	8.5	16	26.5	mA
		I <sub>TRICKLE</sub> = 32mA, V <sub>BATT</sub> = 1V	23	32	43	mA
		I <sub>TRICKLE</sub> = 64mA, V <sub>BATT</sub> = 1V	44	64	88	mA
Auto-recharge battery voltage threshold	V <sub>RECH</sub>	V <sub>BATT</sub> falling, V <sub>RECHG</sub> = 100mV	45	90	130	mV
		V <sub>BATT</sub> falling, V <sub>RECHG</sub> = 200mV	135	190	240	mV
<b>Input Regulation (T<sub>A</sub> = 0°C to 70°C)</b>						
Input minimum voltage regulation	V <sub>IN_LIM</sub>	V <sub>IN_LIM</sub> = 3.88V, V <sub>BATT</sub> = 3.3V	3.758	3.88	4.002	V
		V <sub>IN_LIM</sub> = 4.36V, V <sub>BATT</sub> = 3.3V	4.236	4.36	4.484	V
Input minimum voltage regulation tracking battery	V <sub>IN_LIM_BATT</sub>	V <sub>IN_LIM</sub> = 3.88V, V <sub>BATT</sub> = 4V	70	165	285	mV
Input current limit	I <sub>IN_LIM</sub>	I <sub>IN_LIM</sub> = 500mA	415	450	500	mA
		I <sub>IN_LIM</sub> = 1.5A	1.34	1.41	1.5	A
		I <sub>IN_LIM</sub> = 3A	2.7	2.84	3	A
<b>BATT Over-Voltage Protection (OVP)</b>						
Battery OVP threshold	V <sub>BATT_OVP</sub>	V <sub>BATT</sub> rising, percentage of V <sub>BATT_REG</sub>	103	105	106.5	%
Battery OVP hysteresis				1.7		%
<b>Thermal</b>						
Junction temperature regulation <sup>(8)</sup>	T <sub>J_REG</sub>	T <sub>REG</sub> = 80°C		80		°C
		T <sub>REG</sub> = 120°C		120		°C
Thermal shutdown rising junction temperature <sup>(8)</sup>	T <sub>J_SHDN</sub>	Temperature rising		150		°C
Thermal shutdown hysteresis <sup>(8)</sup>	T <sub>SHDN_HYS</sub>			30		°C



**ELECTRICAL CHARACTERISTICS (continued)**
**T<sub>A</sub> = -40°C to +125°C, T<sub>A</sub> = 25°C, and V<sub>BATT</sub> = 4V for typical values, unless otherwise noted.**

Parameters	Symbol	Condition	Min	Typ	Max	Units
<b>JEITA NTC Monitor (T<sub>A</sub> = 0°C to 70°C)</b>						
NTC cold temperature rising threshold	V <sub>COLD</sub>	As a percentage of V <sub>VRNTC</sub> , V <sub>COLD</sub> = 74.2% (0°C)	73.9	74.5	75.1	%
NTC cold temperature rising threshold hysteresis		As a percentage of V <sub>VRNTC</sub>		1.4		%
NTC cool temperature rising threshold	V <sub>COOL</sub>	As a percentage of V <sub>VRNTC</sub> , V <sub>COOL</sub> = 64.8% (10°C)	64.3	64.9	65.5	%
NTC cool temperature rising threshold hysteresis		As a percentage of V <sub>VRNTC</sub>		1.4		%
NTC warm temperature falling threshold	V <sub>WARM</sub>	As a percentage of V <sub>VRNTC</sub> , V <sub>WARM</sub> = 32.6% (45°C)	31.9	32.5	33.1	%
NTC warm temperature falling threshold hysteresis		As a percentage of V <sub>VRNTC</sub>		1.4		%
NTC hot temperature falling threshold	V <sub>HOT</sub>	As a percentage of V <sub>VRNTC</sub> , V <sub>HOT</sub> = 23% (60°C)	22.7	23.3	23.9	%
NTC hot temperature falling threshold hysteresis		As a percentage of V <sub>VRNTC</sub>		1.4		%
<b>BATTFET Over-Current Protection (OCP)</b>						
BATTFET over-current threshold	I <sub>BATT_OCP</sub>		3.5	4		A
<b>PWM Converter</b>						
Switching frequency	f <sub>SW</sub>	SW_FREQ = 750kHz	630	750	895	kHz
		SW_FREQ = 1000kHz	900	1050	1280	kHz
		SW_FREQ = 1250kHz	1060	1250	1450	kHz
		SW_FREQ = 1500kHz	1260	1475	1680	kHz
<b>Boost</b>						
Boost regulation voltage	V <sub>PMID_REG</sub>	V <sub>BOOST</sub> = 5.15V, T <sub>A</sub> = -40°C to +85°C	5.08	5.15	5.22	V
BATT_LOW comparator falling threshold	V <sub>BATT_LOW</sub>	BATT_LOW = 3V	2.88	3	3.12	V
		BATT_LOW = 3.3V	3.20	3.33	3.46	V
BATT_LOW comparator hysteresis				200		mV
Battery low comparator debounce time	t <sub>D_BATT_LOW</sub>			10		ms
Boost output current limit	I <sub>BST_LIM</sub>	OLIM = 500mA T <sub>A</sub> = 0°C to 70°C	500		615	mA
		OLIM = 1.5A T <sub>A</sub> = 0°C to 70°C	1500		1700	mA
Boost OVP threshold	V <sub>BST_OVP</sub>	Boost mode, V <sub>IN</sub> rising	5.5	5.8	6.1	V
<b>VCC LDO</b>						
VCC output voltage	V <sub>CC</sub>	V <sub>IN</sub> = 5V, I <sub>VCC</sub> = 5mA		3.65		V

**Note:**

8) Guaranteed by design.

**ELECTRICAL CHARACTERISTICS (continued)**

 T<sub>A</sub> = -40°C to +125°C, T<sub>A</sub> = 25°C, and V<sub>BATT</sub> = 4V for typical values, unless otherwise noted.

Parameters	Symbol	Condition	Min	Typ	Max	Units
<b>IB Output (T<sub>A</sub> = 0°C to 70°C)</b>						
IB current output gain	I <sub>IB</sub>	I <sub>IB</sub> , charging, I <sub>BATT</sub> = 50mA, BFET_STAT = 0	1.1	2	2.8	μA
		I <sub>IB</sub> , charging, I <sub>BATT</sub> = 500mA, BFET_STAT = 0	18.2	20	22.1	μA
		I <sub>IB</sub> , discharging, I <sub>BATT</sub> = 50mA, BFET_STAT = 1	1.1	2	2.8	μA
		I <sub>IB</sub> , discharging, I <sub>BATT</sub> = 500mA, BFET_STAT = 1	18.2	20	22.1	μA
<b>Impedance Test</b>						
Input impedance test current	I <sub>VIN_SRC</sub>	I <sub>VIN_SRC</sub> = 10μA	6	10	14	μA
		I <sub>VIN_SRC</sub> = 40μA	28	40	52	μA
		I <sub>VIN_SRC</sub> = 320μA	240	320	405	μA
Input impedance test voltage threshold	V <sub>VIN_TEST</sub>	V <sub>VIN_TEST</sub> = 0.5V	0.46	0.5	0.54	V
		V <sub>VIN_TEST</sub> = 1.5V	1.4	1.5	1.6	V
<b>Logic I/O for SCL, SDA, INT, RST, STAT</b>						
Logic input low voltage	V <sub>IL</sub>				0.4	V
Logic input high voltage	V <sub>IH</sub>		1.3			V
Open drain output low voltage	V <sub>OL</sub>	I <sub>SINK</sub> = 10mA			0.2	V
Pull-up resistor RST	R <sub>PULL_UP</sub>			200		kΩ
<b>D+/D- Detection</b>						
DCD D+ pull-up current	I <sub>DP_SRC</sub>		7	10	13	μA
DCD D- pull-low resistance	R <sub>DM_DWN</sub>		16	20	24	kΩ
D+/D- source voltage low	V <sub>SRC_L</sub>		550	600	650	mV
D+/D- source voltage high	V <sub>SRC_H</sub>		3.1	3.3	3.5	V
D+/D- sink current	I <sub>SNK</sub>		50	100	150	μA
Data detection voltage	V <sub>DAT_REF</sub>		300	350	400	mV
Non-standard 1.2V window	V <sub>1P2_TH</sub>	Low threshold	0.95	1	1.05	V
		High threshold	1.33	1.4	1.47	V
Non-standard 2V window	V <sub>2P0_TH</sub>	Low threshold	1.73	1.8	1.87	V
		High threshold	2.17	2.25	2.33	V
Non-standard 2.7V window	V <sub>2P7_TH</sub>	Low threshold	2.3	2.4	2.5	V
		High threshold	2.9	3	3.1	V

**ELECTRICAL CHARACTERISTICS (continued)**
 $T_A = -40^{\circ}\text{C}$  to  $+125^{\circ}\text{C}$ ,  $T_A = 25^{\circ}\text{C}$ , and  $V_{\text{BATT}} = 4\text{V}$  for typical values, unless otherwise noted.

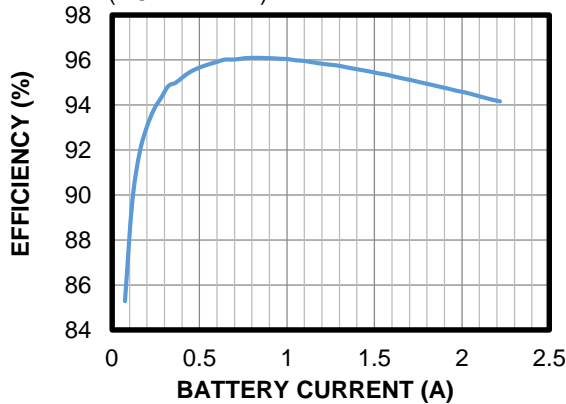
Parameters	Symbol	Condition	Min	Typ	Max	Units
<b>Timing</b>						
<b>Battery Charger</b>						
Charge termination deglitch time	$t_{\text{TERM\_DGL}}$			250		ms
Charge timer	$t_{\text{CHG\_TMR}}$	CHG_TIMER = 10hrs	8	10	12	hr
Top-off timer	$t_{\text{TOP\_OFF}}$	TOPOFF_TIMER = 30 minutes	24	30	36	min
Battery auto-recharge deglitch time	$t_{\text{RECH\_DGL}}$			100		ms
<b>RST Timing</b>						
RST low time to exit shipping mode	$t_{\text{SHIPMODE}}$		0.9	1.1	1.3	sec
RST low time to reset BATTFET	$t_{\text{RST}}$		8	10	12	sec
BATTFET reset time	$t_{\text{SYS\_RST}}$		250	330	400	ms
Enter shipping mode delay	$t_{\text{SHIP\_DLY}}$		10	12	15	sec
<b>Watchdog and Clock</b>						
Watchdog timer	$t_{\text{WDT}}$	WATCHDOG = 40s		40		sec
I <sup>2</sup> C clock	$f_{\text{SCL}}$				400	kHz

**TYPICAL PERFORMANCE CHARACTERISTICS**

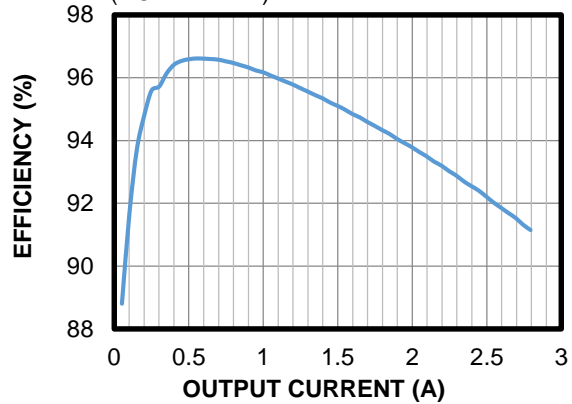
$V_{IN} = 5V$ ,  $V_{BATT} = \text{full range}$ , I<sup>2</sup>C-controlled,  $I_{CC} = 1A$ ,  $I_{IN\_LIM} = 3A$ ,  $V_{IN\_MIN} = 4.36V$ ,  $L = 1\mu H$   
(DCR = 12mΩ),  $T_A = 25^\circ C$ , unless otherwise noted.

**Charge Efficiency**

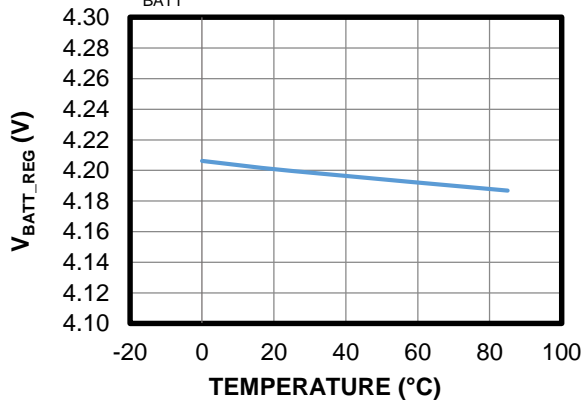
$V_{IN} = 5V, V_{BATT} = 3.8V, L = 1\mu H$   
(DCR = 12mΩ)


**Boost Efficiency**

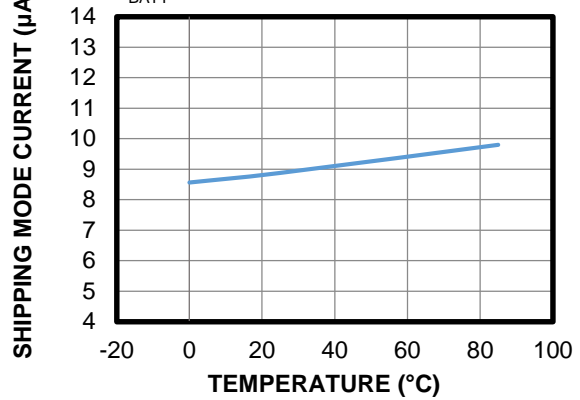
$V_{BATT} = 4.2V, V_{BOOST} = 5.15V, L = 1\mu H$   
(DCR = 12mΩ)


**Battery Regulation Voltage vs. Temperature**

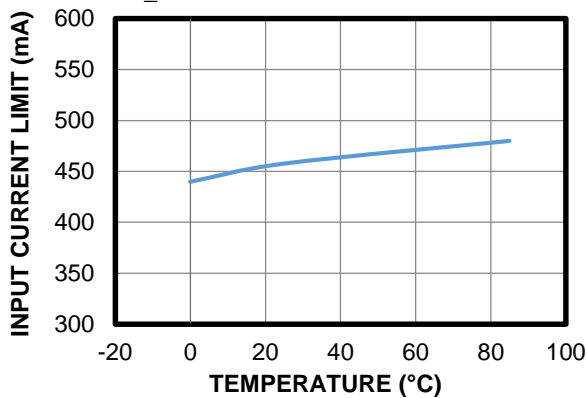
$V_{BATT} = 4.2V$


**Shipping Mode Current vs. Temperature**

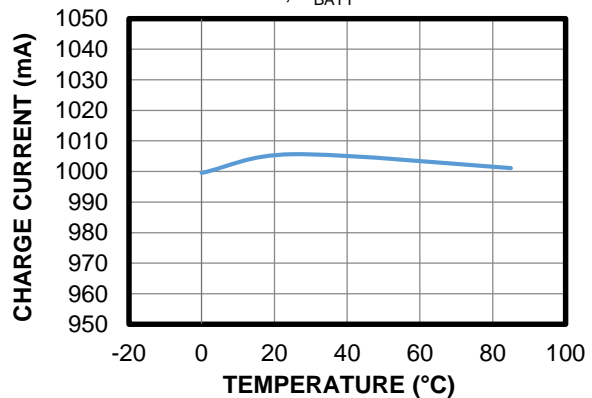
$V_{BATT} = 4V$


**Input Current Limit vs. Temperature**

$I_{IN\_LIM} = 500mA$


**Charge Current vs. Temperature**

$I_{CC} = 1000mA, V_{BATT} = 3.8V$

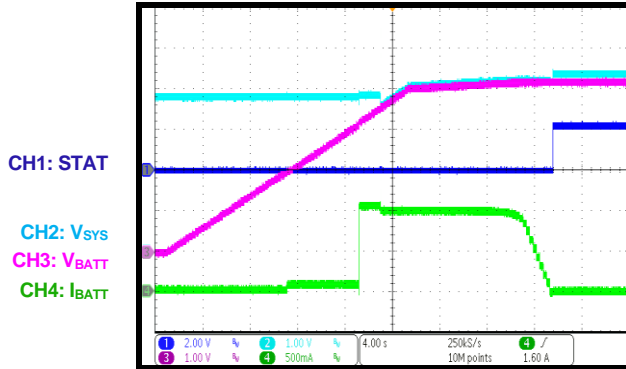


**TYPICAL PERFORMANCE CHARACTERISTICS (continued)**

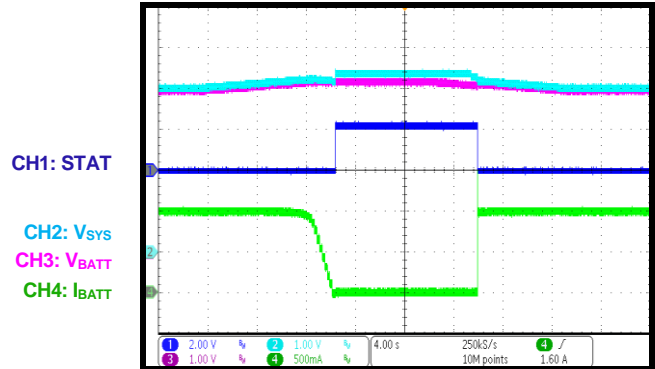
$V_{IN} = 5V$ ,  $V_{BATT} = \text{full range}$ , I<sup>2</sup>C-controlled,  $I_{CC} = 1A$ ,  $I_{IN\_LIM} = 3A$ ,  $V_{IN\_MIN} = 4.36V$ ,  $L = 1\mu H$  (DCR = 12mΩ),  $T_A = 25^\circ C$ , unless otherwise noted.

**Battery Charge Profile**

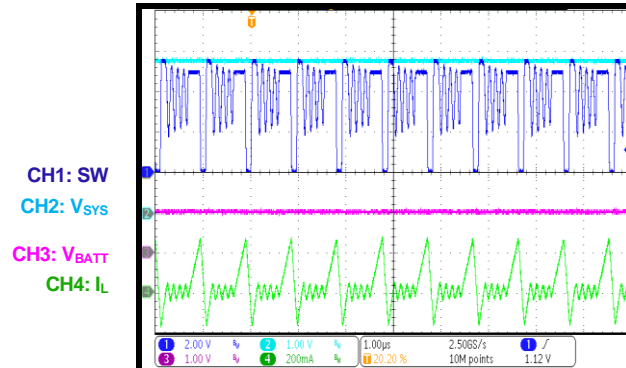
$V_{IN} = 5V$ ,  $I_{PRE} = 80mA$ ,  $I_{CC} = 1A$ ,  $I_{SYS} = 0A$


**Auto-Recharge**

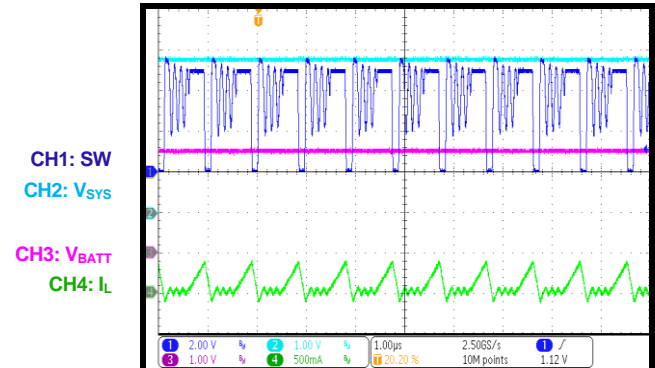
$V_{IN} = 5V$ ,  $I_{CC} = 1A$ ,  $I_{SYS} = 0A$


**Trickle Charge**

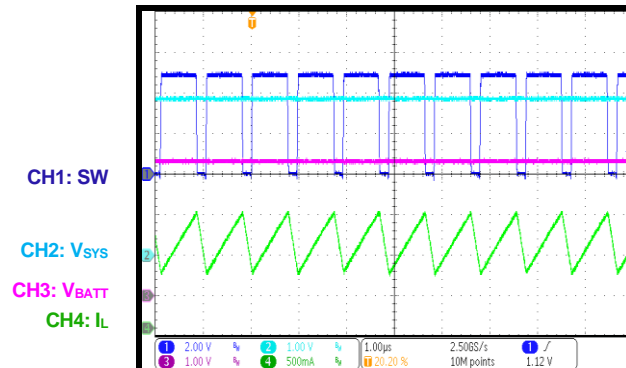
$V_{IN} = 5V$ ,  $V_{BATT} = 1V$ ,  $I_{TC} = 32mA$ ,  $I_{SYS} = 0A$


**Pre-Charge**

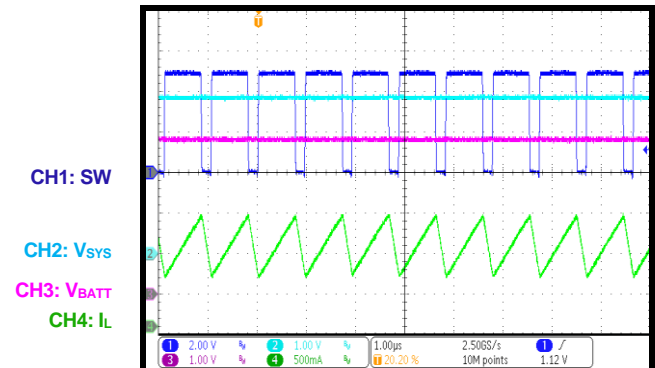
$V_{IN} = 5V$ ,  $V_{BATT} = 2.5V$ ,  $I_{PRE} = 80mA$ ,  $I_{SYS} = 0A$


**Linear CC Charge**

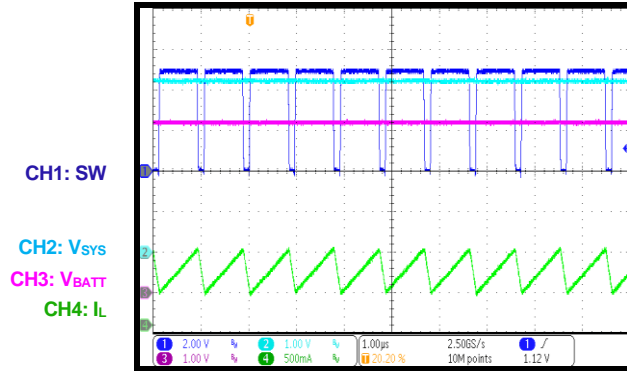
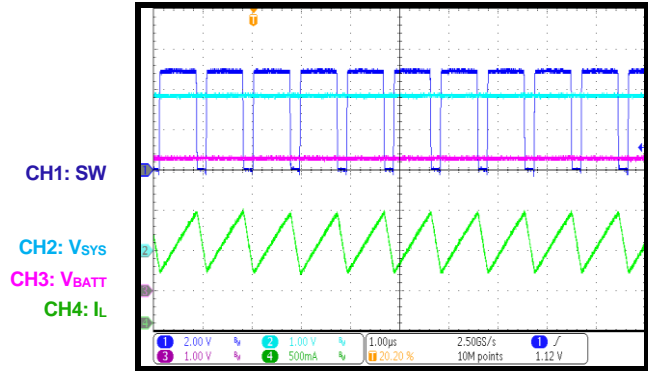
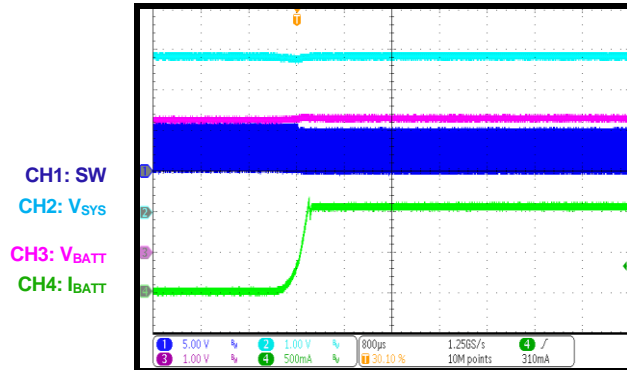
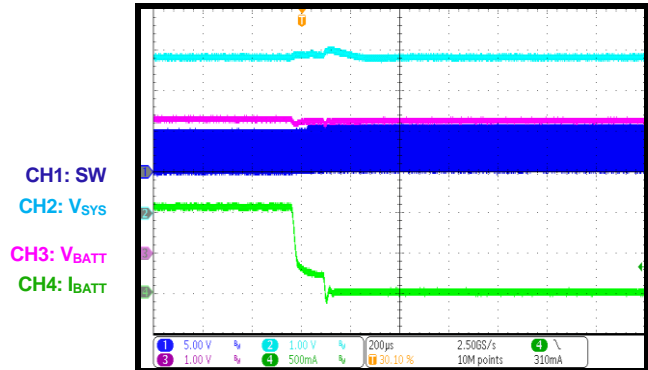
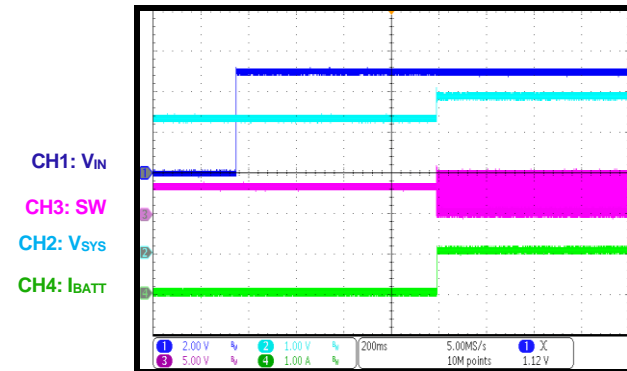
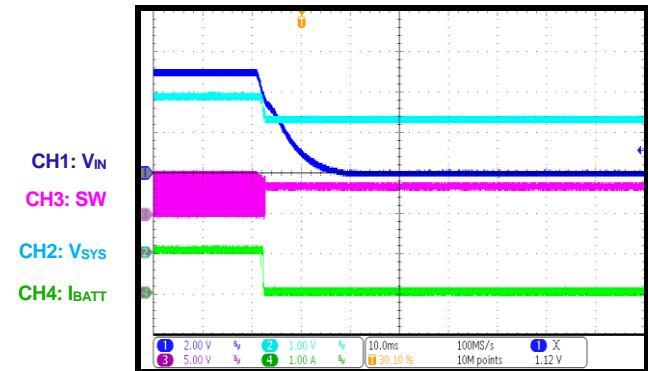
$V_{IN} = 5V$ ,  $V_{BATT} = 3.3V$ ,  $I_{CC} = 1A$ ,  $I_{SYS} = 0A$


**Switching CC Charge**

$V_{IN} = 5V$ ,  $V_{BATT} = 3.8V$ ,  $I_{CC} = 1A$ ,  $I_{SYS} = 0A$



**TYPICAL PERFORMANCE CHARACTERISTICS (continued)**
 $V_{IN} = 5V$ ,  $V_{BATT} = \text{full range}$ , I<sup>2</sup>C-controlled,  $I_{CC} = 1A$ ,  $I_{IN\_LIM} = 3A$ ,  $V_{IN\_MIN} = 4.36V$ ,  $L = 1\mu H$  (DCR = 12m $\Omega$ ),  $T_A = 25^\circ C$ , unless otherwise noted.

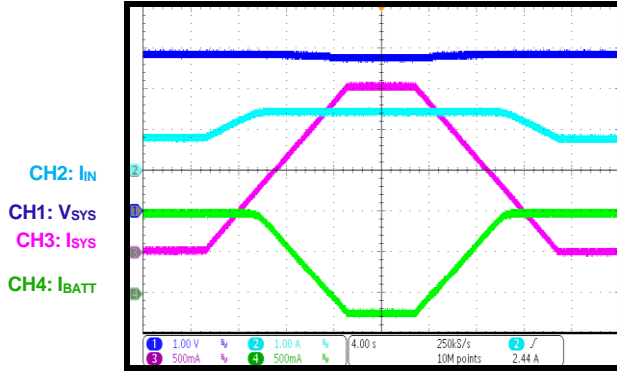
**Constant Voltage Charge**
 $V_{IN} = 5V$ ,  $V_{BATT} = 4.185V$ ,  $I_{SYS} = 0A$ 

**Charge Disabled Steady State**
 $V_{IN} = 5V$ ,  $V_{BATT} = 3.3V$ ,  $I_{SYS} = 1A$ 

**Charging Enabled**
 $V_{IN} = 5V$ ,  $V_{BATT} = 3.3V$ ,  $I_{CC} = 1A$ ,  $I_{SYS} = 0A$ 

**Charging Disabled**
 $V_{IN} = 5V$ ,  $V_{BATT} = 3.3V$ ,  $I_{CC} = 1A$ ,  $I_{SYS} = 0A$ 

**Start-Up**
 $V_{IN} = 5V$ ,  $V_{BATT} = 3.3V$ ,  $I_{CC} = 1A$ ,  $I_{SYS} = 0A$ 

**Shutdown**
 $V_{IN} = 5V$ ,  $V_{BATT} = 3.3V$ ,  $I_{CC} = 1A$ ,  $I_{SYS} = 0A$ 


**TYPICAL PERFORMANCE CHARACTERISTICS (continued)**

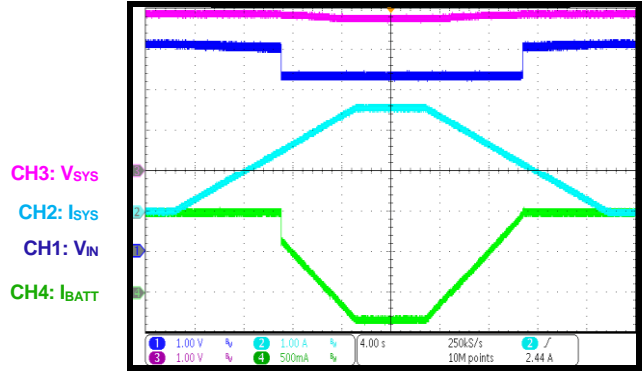
$V_{IN} = 5V$ ,  $V_{BATT} = \text{full range}$ , I<sup>2</sup>C-controlled,  $I_{CC} = 1A$ ,  $I_{IN\_LIM} = 3A$ ,  $V_{IN\_MIN} = 4.36V$ ,  $L = 1\mu H$  (DCR = 12m $\Omega$ ),  $T_A = 25^\circ C$ , unless otherwise noted.

**Input Current Limit**

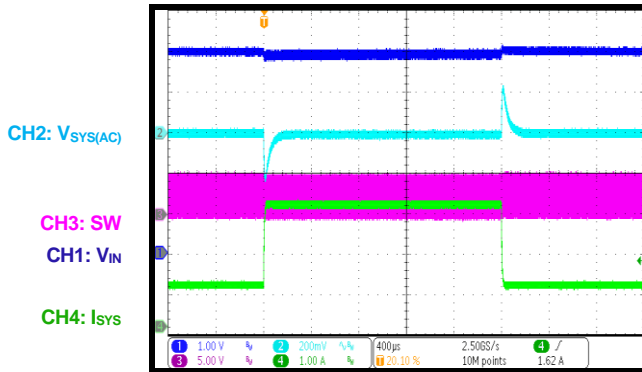
$V_{IN} = 5V$ ,  $I_{IN\_LIM} = 1.5A$ ,  $V_{BATT} = 3.8V$ ,  $I_{CC} = 1A$


**Input Voltage Limit**

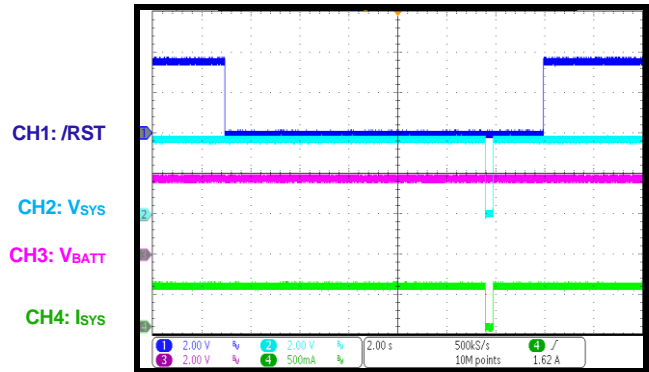
$V_{IN} = 5V$  (2A),  $I_{IN\_LIM} = 3A$ ,  $V_{BATT} = 3.8V$ ,  $I_{CC} = 1A$


**SYS Load Transient Response**

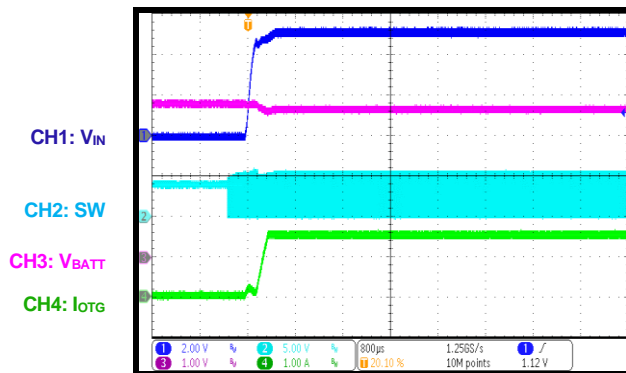
$V_{IN} = 5V$ ,  $V_{BATT} = 3.3V$ , charge disabled,  $I_{SYS} = 1A$  to 3A


**BATTFET Reset**

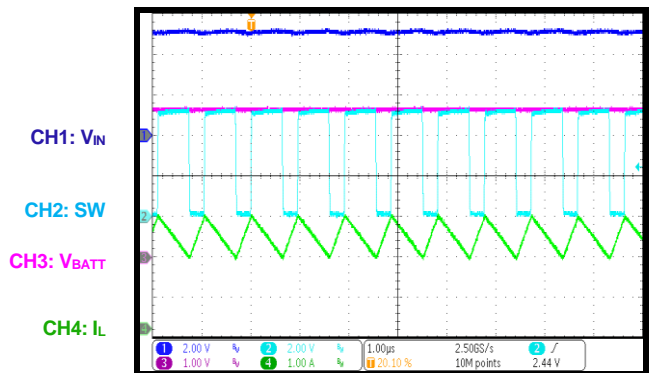
$V_{BATT} = 3.8V$ ,  $I_{SYS} = 0.5A$


**OTG Mode On**

$V_{BATT} = 3.8V$ ,  $V_{BOOST} = 5.15A$ ,  $I_{OTG} = 1.5A$


**OTG Steady State Operation**

$V_{BATT} = 3.8V$ ,  $V_{BOOST} = 5.15V$ ,  $I_{OTG} = 1.5A$







## OPERATION

The MP2720A is a highly integrated, I<sup>2</sup>C-controlled, switch-mode battery charger IC with narrow-voltage DC (NVDC) power path management for the single-cell lithium-ion or lithium-polymer battery applications. The MP2720A integrates the reverse blocking MOSFET (RB-FET, Q<sub>R</sub>), high-side switching MOSFET (HS-FET, Q<sub>H</sub>), low-side switching MOSFET (LS-FET, Q<sub>L</sub>), and battery MOSFET (BATTFET, Q<sub>B</sub>).

### VCC Regulator

The VCC regulator is powered from the higher voltage between the BATT and PMID pins. The VCC pin requires an external 4.7μF bypass capacitor. The VCC pin provides power for the internal circuits and the gate drivers. When the VCC pin voltage (V<sub>CC</sub>) exceeds the VCC under-voltage lockout (UVLO) threshold (V<sub>VCC\_UV</sub>), the I<sup>2</sup>C interface is ready for communication, and all of the registers are reset to their default values. The VCC pin can be used for external logic pull-up, but is not recommended for excess loads.

### Battery Power-On

If an input source is not available, the battery is connected, and the battery voltage (V<sub>BATT</sub>) exceeds the BATT UVLO threshold (V<sub>BATT\_UV</sub>), the BATTFET turns on and powers up the system. The low quiescent current and low voltage drop on BATTFET minimize battery consumption and maximize the battery runtime. The BATTFET's discharge current is monitored. If the system is overloaded or shorted to ground (I<sub>BATT</sub> > I<sub>BATT\_OCP</sub>), the device turns off BATTFET immediately and sets the BATTFET\_DIS bit to 1. The BATTFET can be re-enabled following the methods described in the Exit Shipping Mode section on page 21.

### Input Power-On

When an input source is plugged in, the IC detects the input source type and sets the input current limit (I<sub>IN\_LIM</sub>) before the buck converter starts. The start-up sequence from the input source is described in detail below:

1. The input voltage (V<sub>IN</sub>) is detected.
2. The hold-off timer (about 250ms) runs.
3. Input source type detection starts.
4. I<sub>IN\_LIM</sub> is set.

5. If EN\_BUCK = 1, the buck converter starts.
6. If EN\_CHG = 1, charging starts.

### Hold-Off Timer

When a valid input source is detected, the IC runs a hold-off timer (t<sub>HOLD</sub>, typically about 250ms) before detecting the input source type. t<sub>HOLD</sub> can be bypassed by setting the HOLDOFF\_TMR bit to 0.

### Input Source Type Detection

The IC runs D+/D- detection when all of the following conditions are met:

- V<sub>IN</sub> exceeds V<sub>IN\_UV</sub>
- V<sub>IN</sub> is below V<sub>IN\_OV</sub>
- VIN\_GD = 1
- t<sub>HOLD</sub> ends
- AUTODPDM = 1, or FORCEDPDM is set

D+/D- detection includes USB battery charging specification 1.2 (BC1.2) and non-standard adapter detection. BC1.2 detection begins with data contact detection (DCD). If DCD is successful, the standard downstream port (SDP), dedicated charging port (DCP), and charging downstream port (CDP) are distinguished by primary and secondary detection. If the DCD timer expires, then non-standard adapter detection is initiated. Table 1 lists the criteria for non-standard adapter detection.

**Table 1: Non-Standard Adapter Detection**

Adapter Type	D+ Voltage (V <sub>D+</sub> )	D- Voltage (V <sub>D-</sub> )
Divider 1	V <sub>D+</sub> within V <sub>2P0_TH</sub>	V <sub>D-</sub> within V <sub>2P7_TH</sub>
Divider 2	V <sub>D+</sub> within V <sub>2P7_TH</sub>	V <sub>D-</sub> within V <sub>2P0_TH</sub>
Divider 3	V <sub>D+</sub> within V <sub>2P7_TH</sub>	V <sub>D-</sub> within V <sub>2P7_TH</sub>
Divider 4	V <sub>D+</sub> within V <sub>1P2_TH</sub>	V <sub>D-</sub> within V <sub>1P2_TH</sub>
Divider 5	V <sub>D+</sub> within V <sub>2P7_TH</sub>	V <sub>D-</sub> > V <sub>2P7_TH</sub>

If AUTODPDM = 0, then D+/D- detection is bypassed, and the DPDM\_STAT bits remain set to 0000.

Table 2 on page 18 lists the I<sub>IN\_LIM</sub> settings from D+/D- detection.

**Table 2: Input Current Limit Setting by D+/D- Detection**

D+/D- Detection	Input Current Limit
Not started	500mA
USB SDP	500mA
USB DCP	2A
USB CDP	1.5A
Divider 1	1A
Divider 2	2.1A
Divider 3	2.4A
Divider 4	2A
Divider 5	3A
Unknown	500mA

### Input Current Limit (I<sub>IN\_LIM</sub>) Setting

After input source type detection finishes, the following actions are executed:

- The DPDM\_STAT bits are updated
- I<sub>IN\_LIM</sub> is updated
- The VIN\_RDY bit is set to 1

When the VIN\_RDY bit is set, an INT pulse asserts, and I<sub>IN\_LIM</sub> is updated. The host can overwrite the I<sub>IN\_LIM</sub> registers to modify I<sub>IN\_LIM</sub>.

If the FORCEDPDM bit is written to 1, then D+/D- detection restarts. After D+/D- detection finishes, the DPDM\_STAT bits and I<sub>IN\_LIM</sub> update. An INT pulse follows this action.

### Input Voltage Limit (V<sub>IN\_LIM</sub>) Setting

The MP2720A supports a configurable input voltage limit (V<sub>IN\_LIM</sub>). If V<sub>IN</sub> drops to V<sub>IN\_LIM</sub> due to the input source capability or a cable voltage drop, then the duty cycle is limited to prevent V<sub>IN</sub> from dropping further. This reduces the converter's total output current.

If the EN\_VIN\_TRK bit is set to 0, then the absolute V<sub>IN\_LIM</sub> is set by the VIN\_LIM register. If the EN\_VIN\_TRK bit is set to 1, then V<sub>IN\_LIM</sub> is the maximum value between the VIN\_LIM register's setting and (V<sub>BATT</sub> + 165mV).

### Buck Converter and Charger Start-Up

After the VIN\_RDY bit is set to 1, the buck converter soft starts if EN\_BUCK = 1. The buck converter's switching frequency (f<sub>sw</sub>) can be set between 750kHz and 1.5MHz.

Peak current control mode is adopted to regulate the system voltage (V<sub>SYS</sub>), battery charge current, battery regulation voltage (V<sub>BATT\_REG</sub>), I<sub>IN\_LIM</sub>, V<sub>IN\_LIM</sub>, and the device die temperature loops.

If the EN\_CHG bit is set to 1, the device automatically starts charging

### NVDC Battery MOSFET (BATTFET)

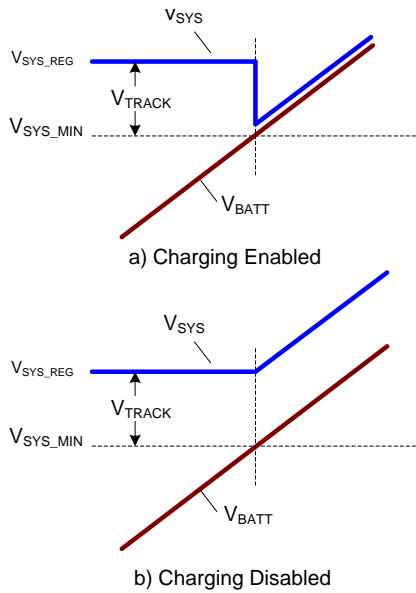
Using the NVDC structure, the BATTFET separates the system from the battery and controls the battery charging and discharging. With power path management, the device prioritizes the system (SYS) output by utilizing the input source, battery, or both.

When the input source is absent, the BATTFET turns fully on to pass the battery power to the system via the ultra-low impedance path. When the input source is present and the buck converter has started up, the system output is related to V<sub>BATT</sub> in the following ways:

1. When V<sub>BATT</sub> is below the minimum system voltage setting (V<sub>SYS\_MIN</sub>), V<sub>SYS</sub> is regulated to (V<sub>SYS\_MIN</sub> + V<sub>TRACK</sub>), where V<sub>TRACK</sub> is typically 150mV. Depending on V<sub>BATT</sub>, the BATTFET works in linear mode to charge the battery with a trickle-charge, pre-charge, or fast charge current.
2. Once V<sub>BATT</sub> exceeds V<sub>SYS\_MIN</sub>, the BATTFET turns on fully and the voltage difference between V<sub>SYS</sub> and V<sub>BATT</sub> is the BATTFET resistive voltage drop.
3. When charging is disabled or terminated, V<sub>SYS</sub> is always regulated to V<sub>TRACK</sub> plus the higher value between V<sub>SYS\_MIN</sub> and V<sub>BATT</sub>. In this scenario, V<sub>TRACK</sub> is typically 100mV.

The status register V<sub>SYS\_STAT</sub> indicates whether the system is in V<sub>SYS\_MIN</sub> regulation.

Figure 3 on page 19 shows V<sub>SYS</sub> regulation as V<sub>BATT</sub> changes.


**Figure 3: V<sub>sys</sub> Regulation with V<sub>batt</sub>**

### Dynamic Power Management

During buck converter operation, the MP2720A continuously monitors the input current ( $I_{IN}$ ) and  $V_{IN}$ . When the input current limit or input voltage limit is reached, the charge current is reduced to prevent the input source from being overloaded.

If the charge current drops to zero,  $V_{SYS}$  starts to drop due to the input power limitation. Once  $V_{SYS}$  falls below  $V_{BATT}$ , the IC automatically enters supplement mode.

If the converter operates in the input current limit or input voltage limit loop, the IINDPM\_STAT or VINDPM\_STAT bit is set to 1, respectively. This is followed by a maskable INT pulse.

### Supplement Mode

When  $V_{SYS}$  falls below  $V_{BATT}$ , the BATTFET turns on to prevent  $V_{SYS}$  from dropping further. In this scenario, the buck converter and the battery work together to provide power for the system.

### Battery Charging

The MP2720A can autonomously run a charging cycle without host involvement. The host can also control the charging operations and parameters via the registers.

A new charge cycle starts when all of the below conditions are met:

- The buck converter has started up
- The NTC pin's (NTC1 and NTC2) voltages are within the acceptable ranges
- BATTFET is on (BATTFET\_DIS = 0)
- Charging is enabled (EN\_CHG = 1)

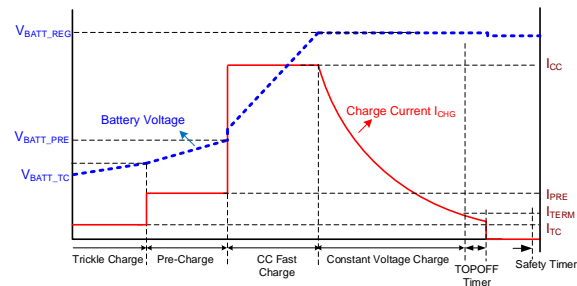
### Charging Profile

The MP2720A detects  $V_{BATT}$  to provide four main charging phases: trickle-charge, pre-charge, constant-current charge and constant-voltage charge (see Table 3).

**Table 3: Charge Current Setting**

Battery Voltage ( $V_{BATT}$ )	Charge Current	Default Value	CHG_STAT
$V_{BATT} < V_{BATT\_TC}$	$I_{TRICKLE}$	16mA	001
$V_{BATT\_TC} \leq V_{BATT} < V_{BATT\_PRE}$	$I_{PRE}$	20mA	010
$V_{BATT\_PRE} \leq V_{BATT} < V_{BATT\_REG}$	$I_{CC}$	140mA	011
$V_{BATT} = V_{BATT\_REG}$	$<I_{CC}$	-	100

Throughout the charging process, the actual charge current may be below the register setting due to other regulation loops, such as the input current loop, input voltage loop, or thermal regulation. In this scenario, charge termination is blocked and the charge timer counts at half of its usual speed if EN\_TMR2X = 1. Figure 4 shows the battery charge profile.


**Figure 4: Battery Charging Profile**

### Charge Termination

If all of the following conditions are met, charging is terminated:

- Termination is enabled (EN\_TERM = 1)
- The charge current is below the termination threshold for  $t_{TEC\_DGL}$  (about 250ms)
- The device is charging in the constant-voltage phase

- The device is not in an input current or input voltage loop
- The device is not in thermal regulation

After termination, the status register CHG\_STAT is set to 101, the STAT pin indicator goes high, and an INT pulse is generated.

To restart a new charge cycle once charging terminates, re-plug in the input source or toggle the EN\_CHG bit.

To fully charge the battery, a top-off timer can be applied after termination is detected. The TOPOFF\_TIMER bits set the top-off timer. The TOPOFF\_ACTIVE bit is 1 when the top-off timer is active. An maskable INT pulse is generated when entering and exiting the top-off time. During top-off timer operation, charging continues, while the CHG\_STAT bits and the STAT pin both indicate that charging is done.

The top-off timer can be reset by any of the conditions listed below:

- Charging changes from disabled to enabled
- Recharging begins
- The REG\_RST bit is set

### Automatic Recharge

When the battery is fully charged and charging is terminated, the battery may be discharged due to system supplement mode or self-discharge. When  $V_{BATT}$  discharges to the recharge threshold, the MP2720A automatically starts a new charging cycle without requiring a manual charge cycle restart, as long as the input power is valid. There is a deglitch timer ( $t_{RECH\_DGL}$ , about 100ms) to detect whether  $V_{BATT}$  is below the recharge threshold. An INT pulse asserts when automatic recharging starts.

### JEITA Thermistor Qualification

The device supports the JEITA profile to manage the charging parameters by continuously monitoring the NTC1 and NTC2 pin voltages. Two independent negative temperature coefficient (NTC) thermistors with temperature sensing and flexible configurations are provided. The NTC1 and NTC2 pins can be enabled and disabled by setting the NTC1\_ACTION and NTC2\_ACTION bits, respectively.

The EN\_PG\_NTC2 bit should be set to 1 to enable the NTC2 channel. When the EN\_PG\_NTC2 bit is set to 0, there will be one NTC monitor only.

If the corresponding NTC channel is enabled, the voltage on the NTC pin must be within the  $V_{HOT}$  to  $V_{COLD}$  range to initiate a charge cycle. If the NTC pin voltage is outside the  $V_{HOT}$  to  $V_{COLD}$  range, then the MP2720A suspends charging and waits for the NTC voltage to return to the standard range.

In the cool temperature range ( $V_{COLD}$  to  $V_{COOL}$ ), the charge current and/or charge voltage are reduced according to the COOL\_ACT, JEITA\_ISET, and JEITA\_VSET settings.

In the warm temperature range ( $V_{WARM}$  to  $V_{HOT}$ ), the charge voltage and/or charge current are reduced according to the WARM\_ACT, JEITA\_ISET, and JEITA\_VSET settings.

The  $V_{COLD}$ ,  $V_{COOL}$ ,  $V_{WARM}$ , and  $V_{HOT}$  thresholds all have four configurable percentage levels.

The temperature conditions can be read in NTC1\_FAULT and/or NTC2\_FAULT bits. An INT pulse is generated when the NTC1 or NTC2 condition changes.

The NTC1 pin and NTC2 pin share the same configurable thresholds. Table 4 shows the detection priority when the detection results between the two NTC inputs are different.

**Table 4: JEITA Detection Priority**

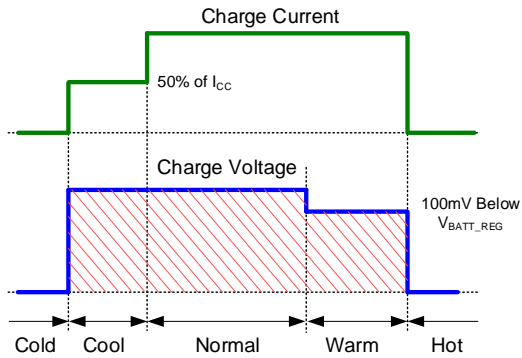
NTC1 \ NTC2	Hot	Warm	Normal	Cool	Cold
Hot	Hot	Hot	Hot	Hot	Hot
Warm	Hot	Warm	Warm	Warm	Cold
Normal	Hot	Warm	Normal	Cool	Cold
Cool	Hot	Warm	Cool	Cool	Cold
Cold	Hot	Cold	Cold	Cold	Cold

For battery temperature protection during boost mode, if the NTC1\_ACTION or NTC2\_ACTION bit is set to 1, the device compares the NTC1 and/or NTC2 pin voltage with the  $V_{COLD}$  and  $V_{HOT}$  thresholds. If the NTC pin voltage is outside the  $V_{COLD}$  to  $V_{HOT}$  range, then boost mode is suspended. The NTC1\_FAULT or NTC2\_FAULT bit is also set to report the condition.

The preset hot, cold, warm, and cool voltage thresholds are defined for a  $\beta = 3435$  thermistor.

It is recommended to use a pull-up resistor with a value that matches the thermistor's resistance at 25°C.

Figure 5 shows the JEITA voltage/current regulations with the following set-up: NTC1\_ACTION = 1, NTC2\_ACTION = 0, WARM\_ACT = 01, COOL\_ACT = 10, JEITA\_VSET = 00, and JEITA\_ISET = 00.



**Figure 5: NTC Window Under JEITA Control**

### Charging Safety Timer

The device has a built-in safety timer to prevent an extended charging cycle due to abnormal battery conditions. When  $V_{BATT}$  is below the  $V_{BATT\_PRE}$  threshold, the safety timer is fixed to 2 hours. When  $V_{BATT}$  exceeds the  $V_{BATT\_PRE}$  threshold, the safety timer is configured by the CHG\_TIMER bits. When the CHG\_TIMER bits are set to 00, both the pre-charge timer and the fast-charge timer are disabled.

Charging is disabled after the safety timer expires. Then the fault register's CHG\_FAULT bit is set to 10, and an INT pulse is generated.

During an input current, input voltage, thermal regulation, or JEITA cool/warm condition (when charge current reduction is enabled), the charge timer counts at half of its usual rate. This halved clock rate function can be disabled by setting the EN\_TMR2X bit to 0.

The charging safety timer resets if any of the following conditions are met:

- The input source is unplugged
- EN\_BUCK or EN\_CHG is toggled
- The REG\_RST bit is set

### Remote Battery Voltage Sense

To minimize the parasitic trace resistance during charging, the BATTSENS pin can be connected to the actual battery pack's positive

terminal. Remote sensing of the battery voltage accelerates the charging speed by helping the charger stay in constant current charge mode for longer.

### Shipping Mode

#### Entering Shipping Mode

When the host sets the BATTFET\_DIS bit to 1, the MP2720A turns off the BATTFET immediately or after a set delay time ( $t_{SHIP\_DLY}$ ), configured by the BATTFET\_DLY bit.

#### Exiting Shipping Mode

When the MP2720A is in shipping mode (BATTFET\_DIS = 1), either of the below events can wake the BATTFET:

- An input source is applied
- The RST pin pulls low for  $t_{SHIPMODE}$

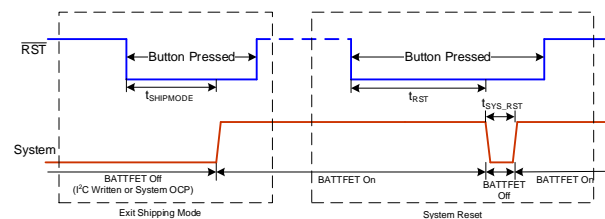
### BATTFET Reset

When the input source is absent, the system is powered by the battery through the BATTFET. The system can be forced to have a hardware power-on reset (POR) by changing the BATTFET status from on to off, then back to on.

For this function, the RST pin can be connected to the device's push-button. The RST pin is pulled up internally.

If the RST pin is driven low for  $t_{RST}$  while the input source is not plugged in, and BATTFET\_DIS = 0, the BATTFET turns off for  $t_{SYS\_RST}$ , then it is enabled again (see Figure 6).

This function can be disabled by setting the BATTFET\_RST\_EN bit to 0.



**Figure 6: RST Timing**

### Power Good (PG) Indication

When EN\_PG\_NTC2 is set to 0, the PG/NTC2 pin acts as the power good (PG) indicator.

This pin goes low to indicate a good input source when all of the following conditions are met:

- $V_{IN}$  exceeds  $V_{IN\_UV}$
- $V_{IN}$  is below  $V_{IN\_OV}$
- The 15ms debounce timer has passed

### STAT and IB Indication

When the EN\_STAT\_IB bit is set to 0, the charging status is indicated on the open-drain STAT/IB pin (see Table 5).

**Table 5: STAT Indication**

Charging State	STAT
Charging	Low
Charging is complete, top-off timer, boost mode, charging is disabled	High
Charging is suspended (due to battery OVP, input OVP, timer fault, or an NTC fault), boost mode is suspended (due to an NTC fault, OTP, or BATT_LOW)	Blinks at 1Hz

When EN\_STAT\_IB is set to 1, the STAT/IB pin acts as an analog current source output that indicates the value of the battery current flowing into or out of the battery. The current's direction can be read via the BFET\_STAT bit. Connect a resistor load between the STAT/IB pin and AGND to sense the IB current. If IB\_EN is set to 1, the IB output is always on. If IB\_EN is set to 0, the IB output is only on when the device is switching.

The IB output voltage ranges between 0V and  $V_{CC}$ . The host can measure the IB voltage to make a software fuel gauge or monitor the peak discharge current.

### Interrupts (INT)

A 256 $\mu$ s interrupt pulse is generated on the open-drain INT pin if any of the interrupt events occur. See the Interrupt List section on page 37 for more details.

### Watchdog Functions (Bark and Bite)

After the first battery or  $V_{IN}$  start-up, the MP2720A operates with the default set-up. The watchdog timer is expired by default when WATCHDOG\_FAULT = 1. Writing 1 to WATCHDOG\_RST starts the watchdog timer.

The watchdog timer has a bark function that generates an INT pulse when the watchdog timer is 3/4 of the way through its timer. The host can distinguish this condition by reading the WATCHDOG\_BARK bit.

To maintain custom settings after the watchdog timer starts, write 1 to the WATCHDOG\_RST bit before the watchdog timer expires. If the watchdog timer expires, the registers are reset according to the register table. After the watchdog timer expires, an INT pulse is sent, and the WATCHDOG\_FAULT bit is set to 1.

The watchdog timer can be disabled by setting the WATCHDOG bit to 00. If the watchdog timer is disabled, the registers keep their values until a POR.

### Boost Mode

By boosting from the battery, the MP2720A can supply a regulated output at the IN pin. Boost mode starts once all of the following conditions are met:

- $V_{IN}$  is below  $V_{IN\_UV}$
- The EN\_BOOST bit is set to 1
- The voltages on the NTC pins (NTC1 and NTC2) are within the acceptable range
- $V_{BATT}$  exceeds  $V_{BATT\_UV}$
- If BOOST\_STP = 1,  $V_{BATT}$  must exceed  $V_{BATT\_LOW}$

The boost PWM's switching frequency is the same as the buck converter's setting.

The boost voltage loop regulates the PMID pin voltage at the value set by the VBOOST bits.

The boost output current loop limits the output current at the value set by OLIM bits for the  $V_{IN} > V_{BATT} + V_{HDRM}$  range.

The boost mode start-up sequence follows the steps below:

- The converter soft starts and regulates the PMID voltage
- The blocking FET ( $Q_R$ ) soft starts and regulates the discharge current from PMID to IN
- Once the IN pin starts up successfully, the boost is controlled to regulate the PMID voltage and the output current sensed through  $Q_R$

The boost converter's soft-start function allows the device to power into large capacitive loads on the IN pin.

### Forced Input Current Limit

When an input source is plugged in during sink mode, the MP2720A runs the start-up sequence and initiates input source type detection. After detection finishes,  $I_{IN\_LIM}$  is automatically generated. The  $I_{IN\_LIM}$  result is returned by the IIN\_LIM bits.

If the host does not want to use the automatically generated  $I_{IN\_LIM}$ , there are two ways to set  $I_{IN\_LIM}$  to different values, via configuring either the IIN\_MODE or IIN\_LIM bits.

If the IIN\_MODE bits are set to 000, the MP2720A runs with the automatically generated  $I_{IN\_LIM}$  (returned by the IIN\_LIM bits). However, once the VIN\_RDY bit is set, the host can override the IIN\_LIM bits to set  $I_{IN\_LIM}$  to any value. This requires host involvement every time the converter starts up.

If the IIN\_MODE bits are set to other values,  $I_{IN\_LIM}$  is forced and fixed. For example, if the IIN\_MODE bits are set to 101, the device always runs with a fixed 2000mA  $I_{IN\_LIM}$ , ignoring the input source type detection.

### Input Impedance Test

The MP2720A supports an input impedance testing function. By sourcing a current on the IN pin, the device can detect the impedance on the connector receptacle (water detection).

The host can write 1 to the VIN\_SRC\_EN bit to turn on the input impedance test by sourcing a current to IN pin. The testing current can be configured via the IVIN\_SRC bits. If  $V_{IN}$  rises to the threshold configured via the VIN\_TEST bit, then VIN\_TEST\_HIGH is set to 1 and latched. This is followed by an INT pulse.

The host can write 0 to the VIN\_SRC\_EN bit to turn off the test current source and clear the VIN\_TEST\_HIGH bit.

The VIN\_SRC\_EN bit can only be effective when neither the buck nor boost is operating, and the current source's maximum pull-up voltage is 2.5V. If  $V_{IN} > V_{IN\_UV}$  is detected during the test, then the VIN\_SRC\_EN and VIN\_TEST\_HIGH bits are reset to 0, and the test ends immediately. If boost mode is enabled during the test, then the VIN\_SRC\_EN and VIN\_TEST\_HIGH bits are reset to 0, and the test ends immediately.

### Lock Function

The MP2720A supports a lock function that limits the value of some key parameters (prevents accidental I<sup>2</sup>C writing). The battery regulation voltage, constant-current charge current, pre-charge current, and JEITA voltage/current settings are some of these parameters.

To enable the lock function, the host can set the above parameters to a target value, then write the LOCK\_CHG bit to 1. After this operation, these parameters can only be written to values lower than the previously set value.

Any of the following events can unlock the parameters:

- The host writes the LOCK\_CHG bit to 0
- The host writes the REG\_RST bit to 0
- The device shuts down

### Protections

#### **Battery Under-Voltage Protection (UVP)**

If the battery is discharged below  $V_{BATT\_UV}$  when the input source is absent, then the BATTFET turns off, and all registers are reset.

#### **BATTFET Over-Current Protection (OCP)**

The MP2720A monitor the BATTFET's current. If SYS is overloaded or experiences a short, and the battery discharge current reaches the  $I_{BATT\_OCP}$  threshold, then the BATTFET turns off and latches. In addition, the BATTFET\_DIS bit is set to 1. To release the latch, apply one of the methods described in the Exiting Shipping Mode section on page 21.

#### **Input Over-Voltage Protection (OVP)**

The MP2720A provides input over-voltage protection (OVP) with a rising threshold of 6.3V. If the IN pin senses a voltage above the  $V_{IN\_OV}$  threshold, the buck converter stops working, the CHG\_FAULT bits are set to 01, and an INT pulse is generated.

When  $V_{IN}$  returns to the normal range, the device runs the start-up sequence again and resumes normal operation. The CHG\_FAULT bits are also cleared.

**Battery Over-Voltage Protection (OVP)**

The battery OV threshold is 104% of  $V_{BATT\_REG}$ . If a battery OV condition is detected, charging is disabled. The fault register CHG\_FAULT bits are set to 11, and an INT pulse asserts.

**Thermal Regulation and Thermal Shutdown**

If the internal junction temperature reaches to the thermal regulation limit ( $T_{J\_REG}$ ) configured via the TREG bits (60°C to 120°C) during battery charging, then the charge current is reduced, charge termination is blocked, and the charge timer runs at half rate. The status register's THERM\_STAT bit is set to 1, followed by a maskable INT pulse.

If the internal junction temperature rises to the shutdown threshold ( $T_{J\_SHDN}$ , about 150°C) at any time, both the converter and BATTFET turn off, and the registers are reset. Once the junction temperature is  $T_{SHDN\_HYS}$  (about 30°C) below  $T_{J\_SHDN}$  (150°C), the MP2720A resumes normal operation.

**Boost Over-Voltage Protection (OVP)**

If  $V_{IN}$  exceeds the regulation target and  $V_{BST\_OVP}$  during boost operation, the device stops switching immediately. The BOOST\_FAULT bits are set to 010, and an INT pulse is generated. Boost operation recovers once  $V_{IN}$  returns to its normal range.

**Boost Overload Protection**

If  $V_{IN}$  drops below the ( $V_{BATT} + V_{HDRM}$ ) or  $V_{IN\_UV}$  threshold due to a heavy load or short during boost operation, the blocking FET turns off and restarts after 500ms. If a total of 8 restarts are not successful, the boost converter stops and latches off. Then the BOOST\_FAULT bits are set to 001, and an INT pulse is generated.

If the IN pin is shorted to GND before the boost converter starts, the blocking FET also restarts 8 times. If this is not successful, the boost converter stops and latches off.

Set the EN\_BOOST bit to 0 to clear the BOOST\_FAULT bits.

**Boost Battery Low Protection**

The MP2720A can protect the battery from being over-drained and prevent a system shutdown during boost operation.

If the BOOST\_STP\_EN bit is set to 1 and  $V_{BATT}$  falls below the BATT\_LOW setting, boost

operation automatically turns off and the MP2720A latches. The BOOST\_FAULT bits are set to 100 and generate a maskable INT pulse. The BATTFET continues operating to provide power to SYS.

The battery low comparator has a 10ms de-bounce time. Change the EN\_BOOST bit to 0 to clear the BOOST\_FAULT bits.

**Boost Over-Temperature Protection**

The MP2720A provides protection from over-temperature conditions in boost mode. If the BOOST\_OTP\_EN bit is set to 1 and the internal junction temperature rises to the thermal regulation limit ( $T_{J\_REG}$ , configured via the TREG bits), then boost operation stops and the MP2720A latches. The BOOST\_FAULT bits are set to 011, followed by an INT pulse. In this scenario, the BATTFET continues operating to provide power to SYS.

Change the EN\_BOOST bit to 0 to clear the BOOST\_FAULT bits.

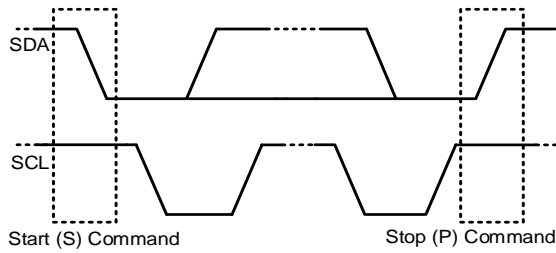
**Serial Interface**

The MP2720A uses an I<sup>2</sup>C-compatible interface to flexibly set charging parameters and instantaneously report the device status. The I<sup>2</sup>C is a two-wire serial interface with two required bus lines: a serial data line (SDA) and a serial clock line (SCL). Both the SDA and SCL lines are open drains that must be connected to the positive supply voltage with a pull-up resistor.

The IC operates as a slave device and receives control inputs from the master device, such as a microcontroller (MCU). The SCL line is always driven by the master device. The I<sup>2</sup>C interface supports both standard mode (up to 100kbps) and fast mode (up to 400kbps).

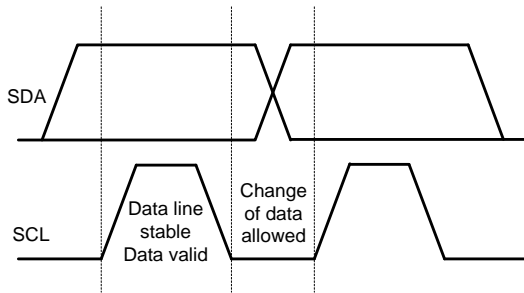
All transactions begin with a start (S) command and are terminated by a stop (P) command. Start and stop commands are always generated by the master. A start command is defined as a high to low transition on the SDA line while SCL is high. A stop command is defined as a low to high transition on the SDA line when the SCL is high (see Figure 7 on page 25).





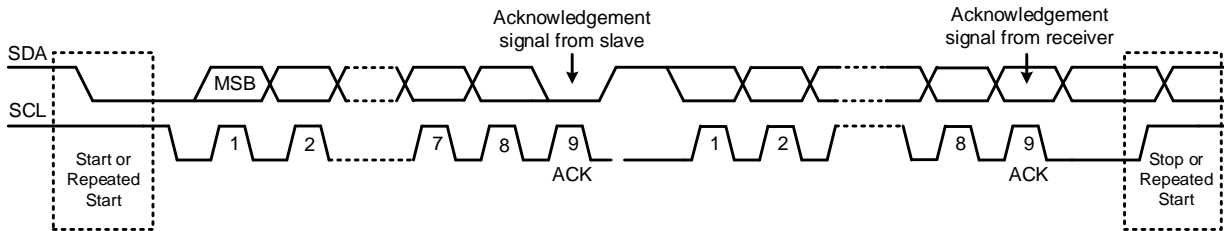
**Figure 7: Start and Stop Commands**

For data validity, the data on the SDA line must be stable during the high period of the clock. The high or low state of the SDA line can only change when the clock signal on the SCL line is low (see Figure 8). Every byte on the SDA line must be 8 bits long. The number of bytes that can be transmitted per transfer is unrestricted. Data is transferred with the most significant bit (MSB) first.

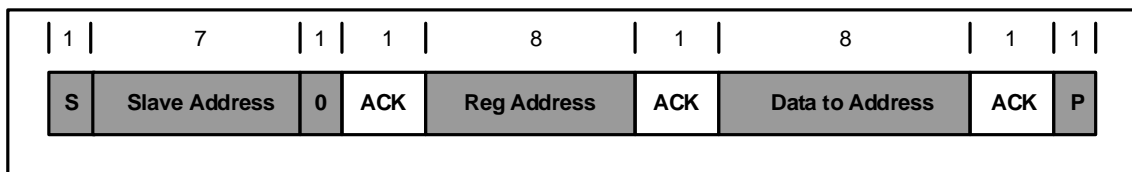


**Figure 8: Bit Transfer on the I<sup>2</sup>C Bus**

Each byte must be followed by an acknowledge (ACK) bit. The ACK bit is generated by the receiver to signal to the transmitter that the byte



**Figure 10: Data Transfer on the I<sup>2</sup>C Bus**



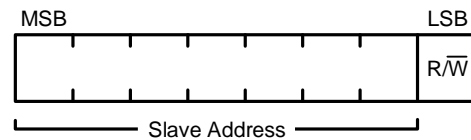
**Figure 11: Single Write Sequence**

was successfully received.

The ACK signal is defined as when the transmitter releases the SDA line during the acknowledge clock pulse. This allows the receiver to pull the SDA line low, which remains low during the high period of the 9th clock pulse.

If the SDA line is high during the 9th clock pulse, this is considered a not acknowledge (NACK) signal. The master can then generate either a stop command to abort the transfer or a repeated start (Sr) command to start a new transfer.

A slave address is sent after the start command. This address is 7 bits long, followed by an 8th data direction bit (R/W). A 0 indicates a transmission (write), and a 1 indicates a request for data (read). Figure 9 shows the address bit arrangement.



**Figure 9: 7-Bit Addressing**

Figure 10 shows a data transfer on the I<sup>2</sup>C bus. Figure 11 shows a single write sequence. Figure 12 on page 26 shows a single read sequence. Figure 13 on page 26 shows a multi-write sequence. Figure 14 on page 26 shows a multi-read sequence.

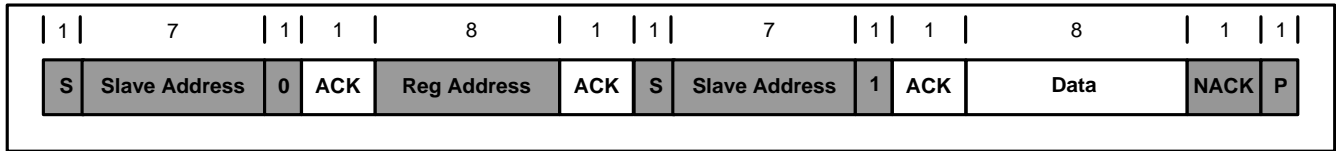


Figure 12: Single Read Sequence

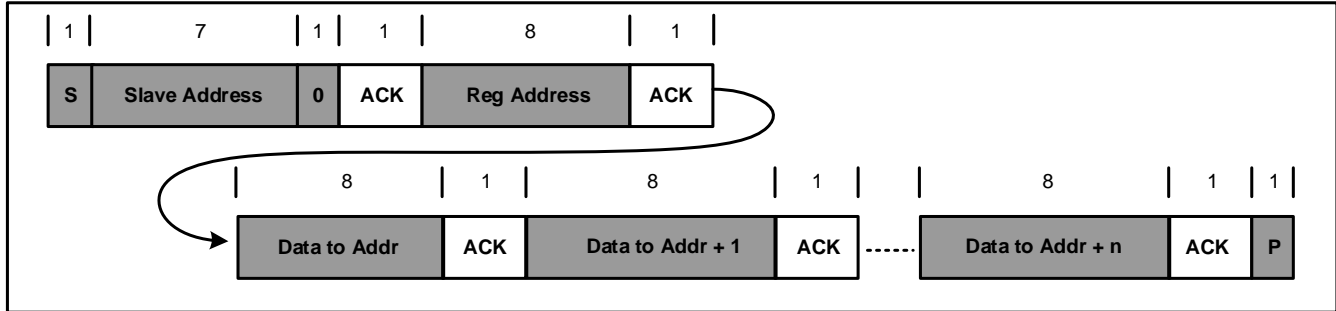


Figure 13: Multi-Write Sequence

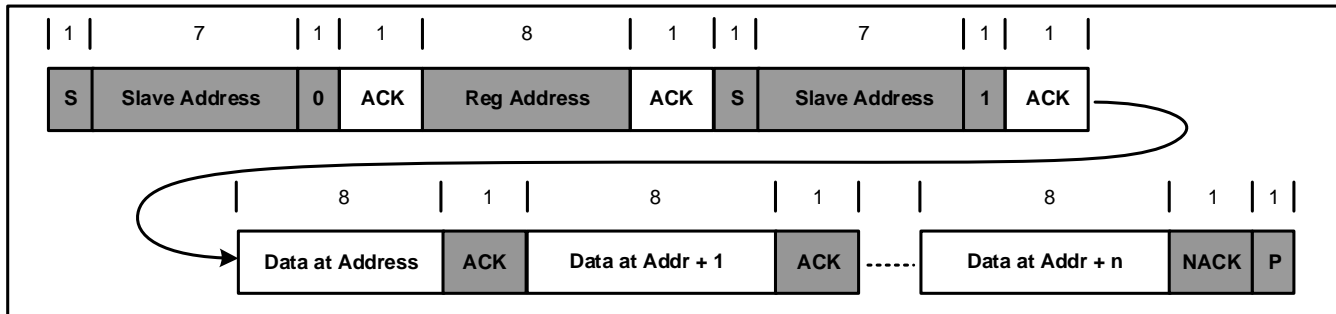


Figure 14: Multi-Read Sequence

## REGISTER MAP

I<sup>2</sup>C Slave Address: 3Fh

Configuration Bytes: 00h~10h

Status Bytes: 11h~16h

### CONFIGURATION BYTES (00h~10h)

**Legend:** POR = default value; WTD = watchdog; R/W = read/write; R = read-only, OTP-configurable = the register's default value can be configured via the OTP

#### REG00h

Bits	Name	POR	WTD Reset	Type	Description	Comments
7	REG_RST	0	-	R/W	Resets the register. 0: Keep the current setting 1: Reset the registers to their default values	This bit returns to 0 after it is written to 1.
6	EN_STAT_IB	0	No	R/W	0: The STAT/IB pin is configured as an open-drain status indicator (STAT) 1: The STAT/IB pin is configured as a battery current indicator (IB)	OTP-configurable.
5	EN_PG_NTC2	0	No	R/W	0: The PG/NTC2 pin is configured as an open-drain power good indicator (PG) 1: The PG/NTC2 pin is configured as a second thermistor input (NTC2)	To enable the NTC2 channel, this bit must be set to 1. OTP-configurable.
4	LOCK_CHG	0	No	R/W	0: Not locked 1: The VBATT[5:0], ICC[4:0], IPRE[2:0], JEITA_VSET[1:0], and JEITA_ISET[1:0] values are locked	After this bit is set to 1, any future writes to VBATT[4:0], ICC[2:0], IPRE[3:0], JEITA_VSET[1:0], and JEITA_ISET[1:0] can only reduce the set values.
3	HOLDOFF_TMR	1	Yes	R/W	0: Disable the hold-off timer 1: Enable the hold-off timer	OTP-configurable.
2	SW_FREQ[1]	0	No	R/W	00: 750kHz 01: 1MHz	Configures both the buck and boost operating frequencies. Default: 1MHz (01) OTP-configurable.
1	SW_FREQ[0]	1	No	R/W	10: 1.25MHz 11: 1.5MHz	
0	EN_VIN_TRK	1	No	R/W	0: V <sub>IN_LIM</sub> is fixed 1: V <sub>IN_LIM</sub> also tracks V <sub>BATT</sub>	When this bit is set to 0, the VIN_LIM register sets the absolute input voltage limit (V <sub>IN_LIM</sub> ) value.  When this bit is set to 1, V <sub>IN_LIM</sub> is the maximum value between VIN_LIM[3:0] and (V <sub>BATT</sub> + 165mV).

**REG01h**

Bits	Name	POR	WTD Reset	Type	Description	Comments
7	IIN_MODE[2]	0	No	R/W	000: Follow the IIN_LIM setting 001: Force I <sub>IN_LIM</sub> to 100mA 010: Force I <sub>IN_LIM</sub> to 500mA 011: Force I <sub>IN_LIM</sub> to 900mA 100: Force I <sub>IN_LIM</sub> to 1500mA 101: Force I <sub>IN_LIM</sub> to 2000mA 110: Force I <sub>IN_LIM</sub> to 3000mA	When setting these bits to 000, the input current limit (I <sub>IN_LIM</sub> ) follows the automatically generated I <sub>IN_LIM</sub> value in IIN_LIM[4:0].  When setting these bits to other values, I <sub>IN_LIM</sub> is fixed.  Default: 000 OTP-configurable.
6	IIN_MODE[1]	0	No	R/W		
5	IIN_MODE[0]	0	No	R/W		
4	IIN_LIM[4]	0	No	R/W	1600mA.	Sets I <sub>IN_LIM</sub> .  Range: 100mA to 3.2A Offset: 100mA Default: 500mA (00100)  This is automatically updated after input source type detection. The host can overwrite the I <sub>IN_LIM</sub> value.
3	IIN_LIM[3]	0	No	R/W	800mA.	
2	IIN_LIM[2]	1	No	R/W	400mA.	
1	IIN_LIM[1]	0	No	R/W	200mA.	
0	IIN_LIM[0]	0	No	R/W	100mA.	

**REG02h**

Bits	Name	POR	WTD Reset	Type	Description	Comments
7	VPRE[1]	1	No	R/W	00: 2.6V 01: 2.8V 10: 3V 11: 3.2V	Sets the pre-charge to fast charge battery voltage threshold.  Default: 3.2V (11)
6	VPRE[0]	1	No	R/W		
5	ICC[5]	0	Yes	R/W	1280mA.	Sets the fast charge current. Do not set this value above 2.2A.  Default: 40mA (000001) OTP-configurable.
4	ICC[4]	0	Yes	R/W	640mA.	
3	ICC[3]	0	Yes	R/W	320mA.	
2	ICC[2]	0	Yes	R/W	160mA.	
1	ICC[1]	0	Yes	R/W	80mA.	
0	ICC[0]	1	Yes	R/W	40mA.	

**REG03h**

Bits	Name	POR	WTD Reset	Type	Description	Comments
7	IPRE[3]	0	Yes	R/W	160mA.	Sets the pre-charge current.  Range: 0mA to 300mA Offset: 0mA Default: 20mA (0001) OTP-configurable.
6	IPRE[2]	0	Yes	R/W	80mA.	
5	IPRE[1]	0	Yes	R/W	40mA.	
4	IPRE[0]	1	Yes	R/W	20mA.	
3	ITERM[3]	0	Yes	R/W	120mA.	Sets the termination current.  Range: 15mA to 240mA Offset: 15mA Default: 30mA (0001) OTP-configurable.
2	ITERM[2]	0	Yes	R/W	60mA.	
1	ITERM[1]	0	Yes	R/W	30mA.	
0	ITERM[0]	1	Yes	R/W	15mA.	

**REG04h**

Bits	Name	POR	WTD Reset	Type	Description	Comment
7	VRECHG	0	Yes	R/W	0: 100mV 1: 200mV	Sets the recharge threshold. Default: 100mV
6	ITRICKLE[2]	0	Yes	R/W	64mA.	Sets the trickle charge current. Range: 0mA to 112mA Offset: 0mA Default: 16mA (001) OTP-configurable.
5	ITRICKLE[1]	0	Yes	R/W	32mA.	
4	ITRICKLE[0]	1	Yes	R/W	16mA.	
3	VIN_LIM[3]	0	No	R/W	640mV.	Sets the input voltage limit (V <sub>IN_LIM</sub> ) threshold. Range: 3.88V to 5.08V Offset: 3.88V Default: 4.36V (0110)
2	VIN_LIM[2]	1	No	R/W	320mV.	
1	VIN_LIM[1]	1	No	R/W	160mV.	
0	VIN_LIM[0]	0	No	R/W	80mV.	

**REG05h**

Bits	Name	POR	WTD Reset	Type	Description	Comment
7	TOPOFF_TMR[1]	0	Yes	R/W	00: Disabled	Sets the timer to stop charging after charge termination.
6	TOPOFF_TMR[0]	0	Yes	R/W	01: 15 minutes 10: 30 minutes 11: 45 minutes	
5	VBATT[5]	0	No	R/W	800mV.	Sets the battery regulation voltage (V <sub>BATT_REG</sub> ). Values above 101000 (4.6V) are clamped to 101000. Range: 3.6V to 4.6V Offset: 3.6V Default: 4.2V (011000) OTP-configurable.
4	VBATT[4]	1	No	R/W	400mV.	
3	VBATT[3]	1	No	R/W	200mV.	
2	VBATT[2]	0	No	R/W	100mV.	
1	VBATT[1]	0	No	R/W	50mV.	
0	VBATT[0]	0	No	R/W	25mV.	

**REG06h**

Bit	Name	POR	WTD Reset	Type	Description	Comment
7	RESERVED	0	No	R	Reserved.	
6	RESERVED	0	No	R	Reserved.	
5	SYS_MIN[2]	1	No	R/W	000: 2.975V 001: 3.15V	Sets the system minimum regulation voltage (V <sub>sys_MIN</sub> ). The actual system regulation voltage is this value plus V <sub>TRACK</sub> = 150mV. Default: 3.588V (100) OTP-configurable
4	SYS_MIN[1]	0	No	R/W	010: 3.325V 011: 3.5V 100: 3.588V 101: 3.675V 110: 3.763V	
3	SYS_MIN[0]	0	No	R/W		
2	TREG[2]	1	Yes	R/W	000: 60°C 001: 70°C	
1	TREG[1]	0	Yes	R/W	010: 80°C 011: 90°C 100: 100°C	
0	TREG[0]	0	Yes	R/W	101: 110°C 110: 120°C	

**REG07h**

Bits	Name	POR	WTD Reset	Type	Description	Comment
7	IB_EN	0	Yes	R/W	0: IB outputs when the switcher is on 1: IB outputs all the time	Enables IB when only the battery is present, which uses about 3µA of battery current. Default: 0
6	WATCHDOG_RST	0	-	R/W	1: Reset the watchdog timer	After writing this bit to 1, the watchdog timer is reset, and this bit returns to 0.
5	WATCHDOG[1]	0	Yes	R/W	00: Disable timer 01: 40s 10: 80s 11: 160s	Default: 40s (01) OTP-configurable.
4	WATCHDOG[0]	1	Yes	R/W		
3	EN_TERM	1	Yes	R/W	0: Disable termination 1: Enable termination	Default: Enable termination (1)
2	EN_TMR2X	1	Yes	R/W	0: Disable 2x timer 1: Enable 2x timer	Default: Enable 2x timer (1)
1	CHG_TIMER[1]	1	Yes	R/W	00: Disable timer 01: 5hrs 10: 10hrs 11: 15hrs	Sets the charge safety timer. Default: 10hrs (10)
0	CHG_TIMER[0]	0	Yes	R/W		

**REG08h**

Bits	Name	POR	WTD Reset	Type	Description	Comment
7	BATTFET_DIS	0	No	R/W	0: Allow BATTFET to remain on 1: Turn off BATTFET	Shipping mode or OCP. Writing to this bit controls whether the BATTFET is on or off. Reading this bit indicates the BATTFET's status.
6	BATTFET_DLY	1	No	R/W	0: Turn off BATTFET immediately 1: Turn off BATTFET after a 10s delay	Sets the delay after BATTFET_DIS is set to 1. Default: Turn off BATTFET after a 10s delay (1)
5	BATTFET_RST_EN	1	Yes	R/W	0: Disable the BATTFET reset function 1: Enable the BATTFET reset function	Default: Enable the BATTFET reset function (1)
4	OLIM[1]	1	Yes	R/W	00: 500mA 01: 1.5A 10: 2.1A 11: 3A	Sets the boost output current limit. Default: 3A (11)
3	OLIM[0]	1	Yes	R/W		
2	VBOOST[2]	1	No	R/W	011: 5.35V 010: 5.3V 001: 5.25V 000: 5.2V 111: 5.15V 110: 5.1V 101: 5.05V 100: 5V	Sets the boost output voltage. Default: 5.15V (111) OTP-configurable.
1	VBOOST[1]	1	No	R/W		
0	VBOOST[0]	1	No	R/W		

**REG09h**

Bits	Name	POR	WTD Reset	Type	Description	Comment
7	RESERVED	0	No	R	Reserved.	
6	RESERVED	1	Yes	R	Reserved.	
5	RESERVED	0	Yes	R	Reserved.	
4	RESERVED	1	Yes	R	Reserved.	
3	RESERVED	0	Yes	R	Reserved.	
2	EN_BOOST	0	Yes	R/W	0: Boost disabled 1: Boost enabled	
1	EN_BUCK	1	Yes	R/W	0: Buck disabled 1: Buck allowed	Set this bit to 0 to force the buck converter off.
0	EN_CHG	1	Yes	R/W	0: Charging disabled 1: Charging allowed	Set this bit to 0 to force charging off.

**REG0Ah**

Bits	Name	POR	WTD Reset	Type	Description	Comment
7	RESERVED	0	No	R	Reserved.	
6	RESERVED	0	No	R	Reserved.	
5	AUTODPDM	1	Yes	R/W	0: D+/D- detection starts manually 1: D+/D- detection automatically starts after VIN_GD = 1 and the hold-off timer ends	Default: 1 OTP-configurable.
4	FORCEDPDM	0	-	R/W	0: Normal 1: Force D+/D- detection	This bit returns to 0 after it is written to 1. This bit is only effective when an input source is applied.
3	RESERVED	0	Yes	R	Reserved.	
2	RESERVED	0	Yes	R	Reserved.	
1	RESERVED	1	Yes	R	Reserved.	
0	RESERVED	1	Yes	R	Reserved.	

**REG0Ch**

Bits	Name	POR	WTD Reset	Type	Description	Comment
7	RESERVED	0	No	R	Reserved.	
6	NTC1_ACTION	0	No	R/W	0: Only generate INT when the NTC1 status changes 1: NTC1 is fully functional	Default: 0 OTP-configurable.
5	NTC2_ACTION	0	No	R/W	0: Only generate INT when the NTC2 status changes 1: NTC2 is fully functional	Default: 0 OTP-configurable.
4	BATT_OVP_EN	1	Yes	R/W	0: Battery OVP is neglected 1: Battery OVP is enabled	Default: 1
3	BATT_LOW[1]	0	No	R/W	00: 3V falling 01: 3.1V falling 10: 3.2V falling 11: 3.3V falling	If $V_{BATT}$ falls below BATT_LOW, an INT pulse is generated with a 10ms debounce. Default: 3V (00)
2	BATT_LOW[0]	0	No	R/W		
1	BOOST_STP_EN	0	Yes	R/W	0: The BATT_LOW comparator only generates INT 1: The BATT_LOW comparator turns off boost operation and latches	Default: 0 OTP-configurable.
0	BOOST_OTP_EN	1	Yes	R/W	0: Boost over-temperature protection is ignored 1: Boost over-temperature protection occurs at TREG	Default: 1 OTP-configurable.

**REG0Dh**

Bits	Name	POR	WTD Reset	Type	Description	Comment
7	WARM_ACT[1]	0	No	R/W	00: No action during an NTC warm condition 01: Reduce $V_{BATT\_REG}$ during an NTC warm condition 10: Reduce $I_{CC}$ during an NTC warm condition 11: Reduce both $V_{BATT\_REG}$ and $I_{CC}$ during an NTC warm condition	If both the NTC1_ACTION and NTC2_ACTION bits are set to 1, see Table 4 on page 20 for more details. Default: 01
6	WARM_ACT[0]	1	No	R/W		
5	COOL_ACT[1]	1	No	R/W	00: No action during an NTC cool condition 01: Reduce $V_{BATT\_REG}$ during an NTC cool condition 10: Reduce $I_{CC}$ during an NTC cool condition 11: Reduce both $V_{BATT\_REG}$ and $I_{CC}$ during an NTC cool condition	If both the NTC1_ACTION and NTC2_ACTION bits are set to 1, see Table 4 on page 20 for more details. Default: 10
4	COOL_ACT[0]	0	No	R/W		
3	JEITA_VSET[1]	0	Yes	R/W	00: $V_{BATT\_REG}$ - 100mV 01: $V_{BATT\_REG}$ - 150mV 10: $V_{BATT\_REG}$ - 200mV 11: $V_{BATT\_REG}$ - 250mV	Default: 00
2	JEITA_VSET[0]	0	Yes	R/W		
1	JEITA_ISET[1]	0	Yes	R/W	00: 50% of $I_{CC}$ 01: 33% of $I_{CC}$ 10: 20% of $I_{CC}$	Default: 00
0	JEITA_ISET[0]	0	Yes	R/W		



**REG0Eh**

Bits	Name	POR	WTD Reset	Type	Description	Comment
7	VHOT[1]	1	Yes	R/W	00: 29.1% (50°C) 01: 25.9% (55°C)	Sets the hot falling threshold, as a percentage of V <sub>VRNTC</sub> . Default: 23% (10)
6	VHOT[0]	0	Yes	R/W	10: 23% (60°C) 11: 20.4% (65°C)	
5	VWARM[1]	0	Yes	R/W	00: 36.5% (40°C) 01: 32.6% (45°C)	Sets the warm falling threshold, as a percentage of V <sub>VRNTC</sub> . Default: 32.6% (01)
4	VWARM[0]	1	Yes	R/W	10: 29.1% (50°C) 11: 25.9% (55°C)	
3	VCOOL[1]	1	Yes	R/W	00: 74.2% (0°C) 01: 69.6% (5°C)	Sets the cool rising threshold, as a percentage of V <sub>VRNTC</sub> . Default: 64.8% (10)
2	VCOOL[0]	0	Yes	R/W	10: 64.8% (10°C) 11: 59.9% (15°C)	
1	VCOLD[1]	0	Yes	R/W	00: 78.4% (-5°C) 01: 74.2% (0°C)	Sets the cold rising threshold, as a percentage of V <sub>VRNTC</sub> . Default: 74.2% (01)
0	VCOLD[0]	1	Yes	R/W	10: 69.6% (+5°C) 11: 64.8% (+10°C)	

**REG0Fh**

Bits	Name	POR	WTD Reset	Type	Description	Comment
7	RESERVED	0	No	R	Reserved.	
6	VIN_SRC_EN	0	Yes	R/W	0: Normal 1: Source current to the IN pin	Enables the input impedance test.
5	IVIN_SRC[3]	0	Yes	R/W	0000: 5μA 0001: 10μA	Configures the input impedance test current source.
4	IVIN_SRC[2]	0	Yes	R/W	0010: 20μA 0011: 40μA	
3	IVIN_SRC[1]	0	Yes	R/W	0100: 80μA 0101: 160μA 0110: 320μA	
2	IVIN_SRC[0]	0	Yes	R/W	0111: 640μA 1000: 1280μA	
1	VIN_TEST[1]	0	Yes	R/W	00: 0.3V 01: 0.5V	Configures the input impedance test comparator threshold.
0	VIN_TEST[0]	0	Yes	R/W	10: 1V 11: 1.5V	

**REG10h**

Bits	Name	POR	WTD Reset	Type	Description	Comment
7	RESERVED	0	No	R	Reserved.	
6	RESERVED	1	No	R	Reserved.	
5	MASK_THERM	0	No	R/W	0: Enable the THERM_STAT INT pulse 1: Mask the THERM_STAT INT pulse	OTP-configurable.
4	MASK_DPM	0	No	R/W	0: Enable the VINDPM and IINDPM INT pulses 1: Mask the VINDPM and IINDPM INT pulses	
3	MASK_TOPOFF	0	No	R/W	0: Enable the TOPOFF timer INT pulse 1: Mask the TOPOFF timer INT pulse	
2	RESERVED	1	No	R	Reserved.	
1	MASK_BATT_LOW	0	No	R/W	0: Enable the BATT_LOW INT pulse 1: Mask the BATT_LOW INT pulse	
0	RESERVED	0	No	R	Reserved.	

**STATUS BYTES (11h~16h)**

**Legend:** POR = default value; R/W = read/write; R = read-only; INT = interrupt; YM = the interrupt can be masked

**REG11h**

Bits	Name	POR	R/W	INT	Description
7	DPDM_STAT[3]	-	R	No	Returns the input source D+/D- detection result.
6	DPDM_STAT[2]	-	R	No	0000: Not started (500mA) 0001: USB SDP (500mA) 0010: USB DCP (2A) 0011: USB CDP (1.5A)
5	DPDM_STAT[1]	-	R	No	0100: Divider 1 (1A) 0101: Divider 2 (2.1A) 0110: Divider 3 (2.4A) 0111: Divider 4 (2A)
4	DPDM_STAT[0]	-	R	No	1000: Unknown (500mA) 1001: USB DCP (2A) 1110: Divider 5 (3A)
3	RESERVED	-	R	No	Reserved.
2	RESERVED	-	R	No	Reserved.
1	VINDPM_STAT	-	R	YM	0: Not in VINDPM 1: In VINDPM
0	IINDPM_STAT	-	R	YM	0: Not in IINDPM 1: In IINDPM

**REG12h**

Bits	Name	POR	R/W	INT	Description
7	RESERVED	-	R	No	Reserved.
6	VIN_GD	-	R	Yes	When $V_{VIN\_UV} < V_{IN} < V_{VIN\_OV}$ in buck mode, this bit is set to 1 and the PG pin is driven low (after a 15ms debounce time). 0: The input source is not valid 1: The input source is good
5	VIN_RDY	-	R	Yes	Indicates whether input source type detection has finished. IIN_LIM[4:0] is updated. 0: $V_{IN}$ is not ready to charge 1: $V_{IN}$ is ready to charge
4	RESERVED	-	R	No	Reserved.
3	THERM_STAT	-	R	YM	0: Not in thermal regulation 1: In thermal regulation
2	VSYS_STAT	-	R	No	0: $V_{BATT} < V_{SYS\_MIN}$ 1: $V_{BATT} > V_{SYS\_MIN}$
1	WATCHDOG_FAULT	-	R	Yes	0: Normal 1: The watchdog timer has expired
0	WATCHDOG_BARK	-	R	Yes	0: Normal 1: The 3/4 watchdog timer has expired

**REG13h**

Bits	Name	POR	R/W	INT	Description
7	CHG_STAT[2]	-	R	No	000: Not charging 001: Trickle charge 010: Pre-charge 011: Fast charge 100: Constant voltage charge 101: Charging is done
6	CHG_STAT[1]	-	R	No	
5	CHG_STAT[0]	-	R	No	
4	BOOST_FAULT[2]	-	R	Yes	000: Normal 001: An IN overload or short (latch-off) has occurred 010: Boost over-voltage protection (OVP) (not latch) has occurred 011: Boost over-temperature protection (latch-off) has occurred 100: The boost has stopped due to BATT_LOW (latch-off)
3	BOOST_FAULT[1]	-	R	Yes	
2	BOOST_FAULT[0]	-	R	Yes	
1	CHG_FAULT[1]	-	R	Yes	00: Normal 01: Input OVP 10: The charge timer has expired 11: Battery OVP
0	CHG_FAULT[0]	-	R	Yes	

**REG14h**

Bits	Name	POR	R/W	INT	Description
7	NTC_MISSING	-	R	Yes	0: Normal 1: NTC is missing ( $V_{NTC} > 95\%$ of $V_{VRNTC}$ )
6	BATT_MISSING	-	R	Yes	0: Normal 1: The battery is missing (2 terminations detected within 3 seconds)
5	NTC1_FAULT[2]	-	R	Yes	000: Normal 001: Warm 010: Cool 011: Cold 100: Hot
4	NTC1_FAULT[1]	-	R	Yes	
3	NTC1_FAULT[0]	-	R	Yes	
2	NTC2_FAULT[2]	-	R	Yes	000: Normal 001: Warm 010: Cool 011: Cold 100: Hot
1	NTC2_FAULT[1]	-	R	Yes	
0	NTC2_FAULT[0]	-	R	Yes	

**REG16h**

Bits	Name	POR	R/W	INT	Description
7	RESERVED	-	R	No	Reserved.
6	TOPOFF_ACTIVE	-	R	YM	0: The top-off timer is not counting 1: The top-off timer is counting
5	BFET_STAT	-	R	No	0: The battery is charging or disabled 1: The battery is discharging
4	BATT_LOW_STAT	-	R	YM	The hysteresis = 200mV. 0: $V_{BATT}$ is greater than BATT_LOW[1:0] 1: $V_{BATT}$ is below BATT_LOW[1:0]
3	RESERVED	-	R	No	Reserved.
2	VIN_TEST_HIGH	-	R	Yes	0: $V_{IN}$ is below the VIN_TEST threshold 1: $V_{IN}$ has reached the VIN_TEST threshold
1	RESERVED	-	R	No	Reserved.
0	RESERVED	-	R	No	Reserved.

**INTERRUPT LIST**

INT Name	Related Registers	Can Be Masked	Event
VIN_GD	VIN_GD changes	No	A good input source has been detected.
DPDM_DET_DONE	DPDM_STAT[3:0] changes	No	DPDM detection is finished.
VIN_RDY	VIN_RDY: 0 to 1	No	The input current limit has been updated; the buck converter has started.
CHG_DONE	CHG_STAT[2:0]: any value to 101	No	Charging has terminated.
RECHARGE	CHG_STAT[2:0] exits 101 and enters the CC/CV charge	No	Recharging has been initiated.
THERM_STAT	THERM_STAT: 0 to 1	Yes	The IC has entered charge thermal regulation.
WATCHDOG_FAULT	WATCHDOG_FAULT: 0 to 1	No	A watchdog timeout has occurred.
WATCHDOG_BARK	WATCHDOG_BARK: 0 to 1	No	A watchdog bark has occurred.
CHG_FAULT	CHG_FAULT[1:0]: <ul style="list-style-type: none"> <li>• 00 to 01</li> <li>• 00 to 10</li> <li>• 00 to 11</li> </ul>	No	One of the following charge faults has occurred: input OVP, battery OVP, or the charge timer has expired.
NTC_MISSING	NTC_MISSING changes	No	NTC is missing.
BATT_MISSING	BATT_MISSING changes	No	BATT is missing.
BOOST_FAULT	BOOST_FAULT[2:0]: <ul style="list-style-type: none"> <li>• 000 to 001</li> <li>• 000 to 010</li> <li>• 010 to 000</li> <li>• 000 to 011</li> <li>• 000 to 100</li> </ul>	No	One of the following boost faults has occurred: IN overloaded or short, Boost OVP, Boost OTP, Boost stops due to BATT_LOW.
NTC_FAULT	NTC1_FAULT[2:0] or NTC2_FAULT[2:0] changes	No	The NTC status has changed.
VINDPM_STAT	VINDPM_STAT: 0 to 1	Yes	The V <sub>IN</sub> regulation loop has been entered.
IINDPM_STAT	IINDPM_STAT: 0 to 1		The I <sub>IN</sub> regulation loop has been entered.
TOPOFF_TMR	TOPOFF_ACTIVE changes	Yes	The TOPOFF timer has started and ended.
BATT_LOW	BATT_LOW_STAT: 0 to 1	Yes	V <sub>BATT</sub> has dropped to the BATT_LOW threshold.
VIN_TEST_HIGH	VIN_TEST_HIGH: 0 to 1	No	V <sub>IN</sub> has reached the VIN_TEST threshold during the input impedance test.

## ONE-TIME PROGRAMMABLE (OTP) MAP

The MP2720A has a one-time programmable (OTP) function to configure the default values for certain registers. The OTP map below shows the OTP-configurable commands.

#	Bit[7]	Bit[6]	Bit[5]	Bit[4]	Bit[3]	Bit[2]	Bit[1]	Bit[0]
00h	N/A	EN_STAT_IB	EN_PG_NTC2	N/A	HOLDOFF_TMR	SW_FREQ[1:0]		N/A
01h	IIN_MODE			N/A	N/A	N/A	N/A	N/A
02h	N/A	N/A	ICC[5:0]					
03h	IPRE[3:0]				ITERM[3:0]			
04h	N/A	ITRICKLE[2:0]			N/A			
05h	N/A	N/A	VBATT[5:0]					
06h	N/A	N/A	SYS_MIN[2:0]			N/A	N/A	N/A
07h	N/A	N/A	WATCHDOG[1:0]	N/A	N/A	N/A	N/A	N/A
08h	N/A	N/A	N/A	N/A	N/A	VBOOST[2:0]		
0Ah	N/A	N/A	AUTODPDM	N/A	N/A	N/A	N/A	N/A
0Ch	N/A	NTC1_ACTION	NTC2_ACTION	N/A	N/A	N/A	BOOST_STP_EN	BOOST_OTP_EN
10h	N/A	N/A	MASK_THERM	N/A	N/A	N/A	N/A	N/A

**ONE-TIME PROGRAMMABLE (OTP) DEFAULT**

OTP Items	Default
EN_STAT_IB	0: STAT
EN_PG_NTC2	0: PG
HOLDOFF_TMR	1: Enable the hold-off timer
SW_FREQ[1:0]	01: 1MHz
IIN_MODE[2:0]	000: Follow the IIN_LIM setting
ICC[5:0]	000001: 40mA
IPRE[3:0]	0001: 20mA
ITERM[3:0]	0001: 30mA
ITRICKLE[2:0]	001: 16mA
VBATT[5:0]	011000: 4.2V
SYS_MIN[2:0]	100: 3.588V
WATCHDOG[1:0]	01: 40s
VBOOST[2:0]	111: 5.15V
AUTODPDM	1: D+/D- detection automatically starts
NTC1_ACTION	0: INT only
NTC2_ACTION	0: INT only
BOOST_STP_EN	0: The BATT_LOW comparator only generates INT
BOOST_OTP_EN	1: Boost operation stops when TREG occurs
MASK_THERM	0: Allow INT

## APPLICATION INFORMATION

### Selecting the Inductor

Inductor selection is a tradeoff between cost, size, and efficiency. A lower-value inductor corresponds to a smaller size, but it also results in a higher current ripple, higher magnetic hysteretic losses, and higher output capacitances. A higher-value inductor results in a lower ripple current and smaller output filter capacitors, but it also results in higher inductor DC resistance (DCR) loss.

Estimate the required inductance with Equation (1):

$$L = \frac{V_{IN} - V_{SYS}}{\Delta I_{L\_MAX}} \times \frac{V_{SYS}}{V_{IN} \times f_{SW}} \quad (1)$$

Where  $V_{IN}$  is the input voltage,  $V_{SYS}$  is the converter's output voltage,  $f_{SW}$  is the switching frequency, and  $\Delta I_{L\_MAX}$  is the maximum peak-to-peak inductor current, which is typically designed to be 20% to 40% of the maximum load current.

Choose an inductor that does not saturate under the worst-case load condition, calculated with Equation (2):

$$I_{SAT} > I_{LOAD} + \frac{\Delta I_{L\_MAX}}{2} \quad (2)$$

Where  $I_{SAT}$  is the inductor saturation current, and  $I_{LOAD}$  is the buck converter's maximum load.

### Selecting the PMID Capacitor ( $C_{PMID}$ )

The PMID capacitor ( $C_{PMID}$ ) decouples the switching buck converter and absorbs the switching ripple current. Select  $C_{PMID}$  based on the demand for the PMID current ripple. The input current ripple can be calculated with Equation (3):

$$I_{RMS\_MAX} = I_{LOAD} \times \frac{\sqrt{V_{SYS} \times (V_{IN} - V_{SYS})}}{V_{IN}} \quad (3)$$

Use low-ESR ceramic capacitors with an X7R or X5R rating for  $C_{PMID}$ . This capacitor should be placed as close to the PMID and PGND pins as possible. The capacitor's voltage rating must exceed  $V_{IN}$ , and it is recommended to consider the plug-in overshoot voltage. A capacitor rated for at least 25V is recommended for applications with a 15V  $V_{IN}$ . Generally, a capacitance of 10 $\mu$ F is considered a sufficient starting value.



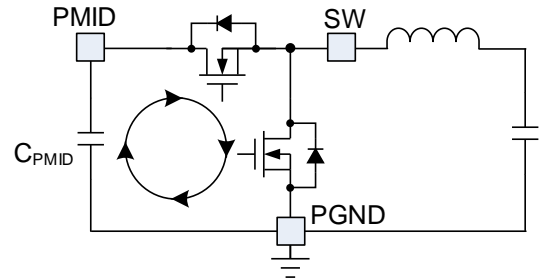
### PCB Layout Guidelines

PCB layout is important to meet specified noise, efficiency and stability requirements. For the best results, refer to Figure 15 and follow the guidelines below:

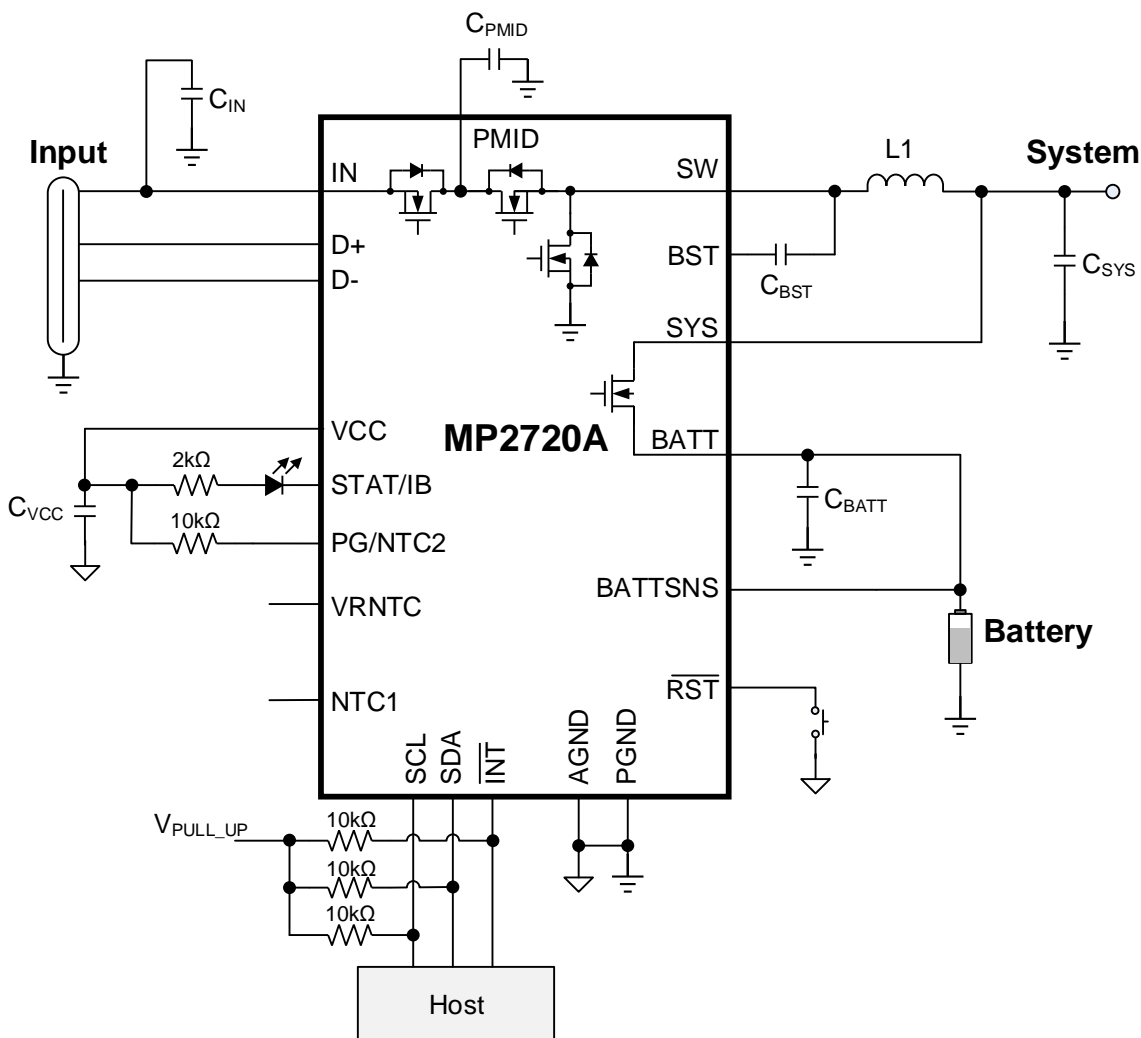
1. Place the PMID capacitor as close as possible to the PMID and PGND pins using a short copper plane connection.
2. Place the PMID capacitor on the same layer as the IC.
3. Minimize the high-frequency current path loop between the PMID capacitor and the buck converter power MOSFETs (from the PMID pin to the capacitor to ground).
4. Place the inductor's input terminal as close as possible to the SW pin.
5. Minimize the copper area of the inductor's input terminal trace to reduce electrical and magnetic field radiation, but ensure that the trace is wide enough to carry the charging current.

6. Minimize parasitic capacitance from the inductor input terminal to any other trace or plane.
7. Place decoupling capacitors (e.g. the VCC pin capacitor) as close as possible to the IC pins, and make the connection as short as possible.
8. Connect the IC's power pin to as many copper planes as possible to conduct heat away from the IC.
9. Ensure that the number and physical size of the vias are sufficient for a current path.

Figure 15 shows a high-frequency current path. In this figure, the high-frequency path (the high-side MOSFET, low-side MOSFET and the PMID capacitor) must be minimized.



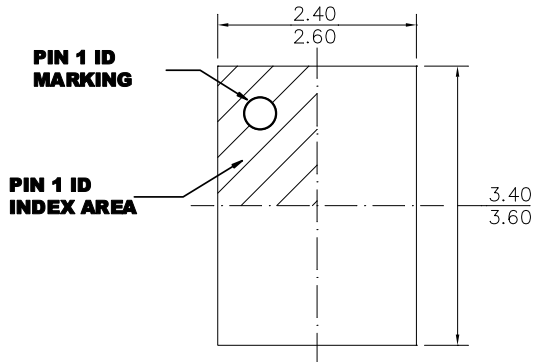
**Figure 15: High-Frequency Current Path**

**TYPICAL APPLICATION CIRCUIT**

**Figure 16: Typical Application Circuit**
**Table 6: The Key BOM for Figure 16**

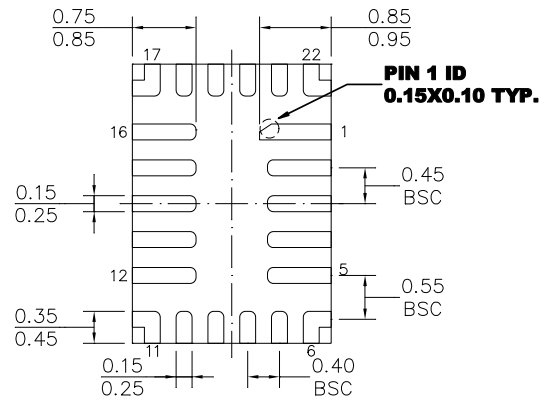
Qty	Ref	Value	Description	Package	Manufacturer
1	C <sub>IN</sub>	1μF	Ceramic capacitor, 25V, X5R or X7R	0603	Any
1	C <sub>PMID</sub>	10μF	Ceramic capacitor, 25V, X5R or X7R	0805	Any
2	C <sub>SYS</sub>	10μFx2	Ceramic capacitor, 16V, X5R or X7R	0805	Any
1	C <sub>BATT</sub>	10μF	Ceramic capacitor, 16V, X5R or X7R	0805	Any
1	C <sub>VCC</sub>	4.7μF	Ceramic capacitor, 10V, X5R or X7R	0603	Any
1	C <sub>BST</sub>	22nF	Ceramic capacitor, 16V, X5R or X7R	0603	Any
1	L1	1μH	Inductor, 1μH, Low DCR	SMD	Any

**PACKAGE INFORMATION**

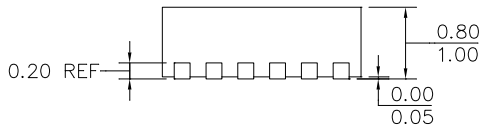
**QFN-22 (2.5mmx3.5mm)**



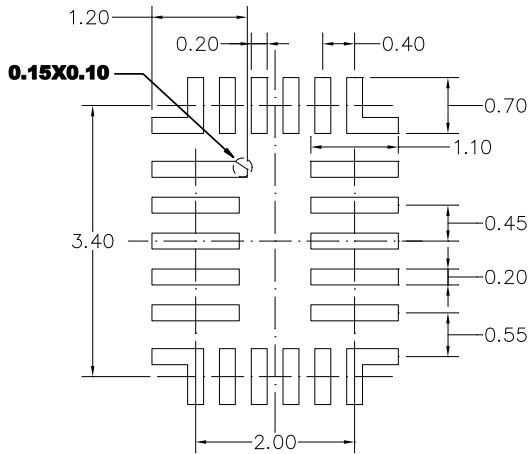
**TOP VIEW**



**BOTTOM VIEW**



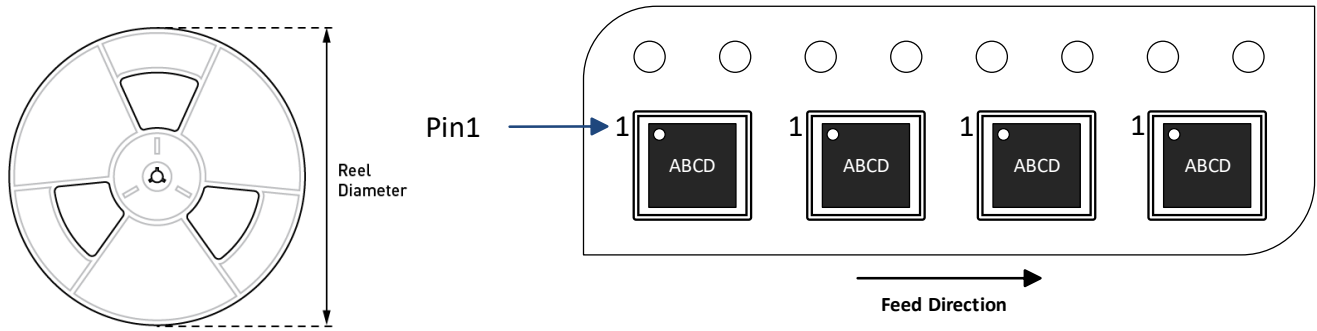
**SIDE VIEW**



**RECOMMENDED LAND PATTERN**

**NOTE:**

- 1) ALL DIMENSIONS ARE IN MILLIMETERS.
- 2) LEAD COPLANARITY SHALL BE 0.08 MILLIMETERS MAX.
- 3) JEDEC REFERENCE IS MO-220.
- 4) DRAWING IS NOT TO SCALE.

**CARRIER INFORMATION**


Part Number	Package Description	Quantity/ Reel	Quantity/ Tube	Quantity/ Tray	Reel Diameter	Carrier Tape Width	Carrier Tape Pitch
MP2720AGRH- xxxx-Z	QFN-22 (2.5mmx3.5mm)	5000	N/A	N/A	13in	12mm	8mm

## REVISION HISTORY

Revision #	Revision Date	Description	Pages Updated
1.0	11/4/2022	Initial Release	-

**Notice:** The information in this document is subject to change without notice. Please contact MPS for current specifications. Users should warrant and guarantee that the third-party Intellectual Property rights are not infringed upon when integrating MPS products into any application. MPS will not assume any legal responsibility for any said applications.