

Low Profile Aluminum Load Cell

FEATURES

- Capacities 10–30 kg
- Aluminum construction
- Single-point 350 x 350 mm platform
- Patent-pending vLite™ technology
- OIML R60, NTEP, ATEX, IECEx, UKCA and FM approvals pending.
- IP66 protection

APPLICATIONS

- Bench scales
- Counting scales
- Grocery scales

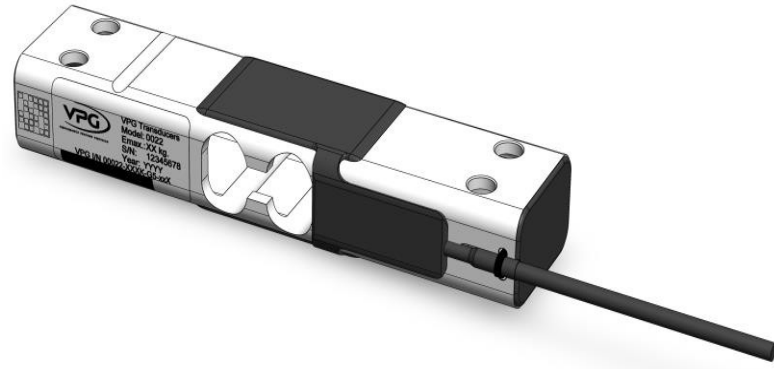

DESCRIPTION

Model 0022 is a low-profile, single-point load cell designed for direct mounting in weighing scales/platforms. Leveraging vLite™ technology, it is constructed from aviation-grade metal, with a hollow beam.

Its small physical size and light weight, combined with high accuracy and low cost, make this load cell ideally suited for retail, bench and counting scales.

Supplied as standard in anodized aluminum, this high-accuracy load cell is pending approval to OIML & NTEP standards.

A proprietary triple-redundant humidity-resistant protective construction assures long-term stability over a wide range of environmental conditions.

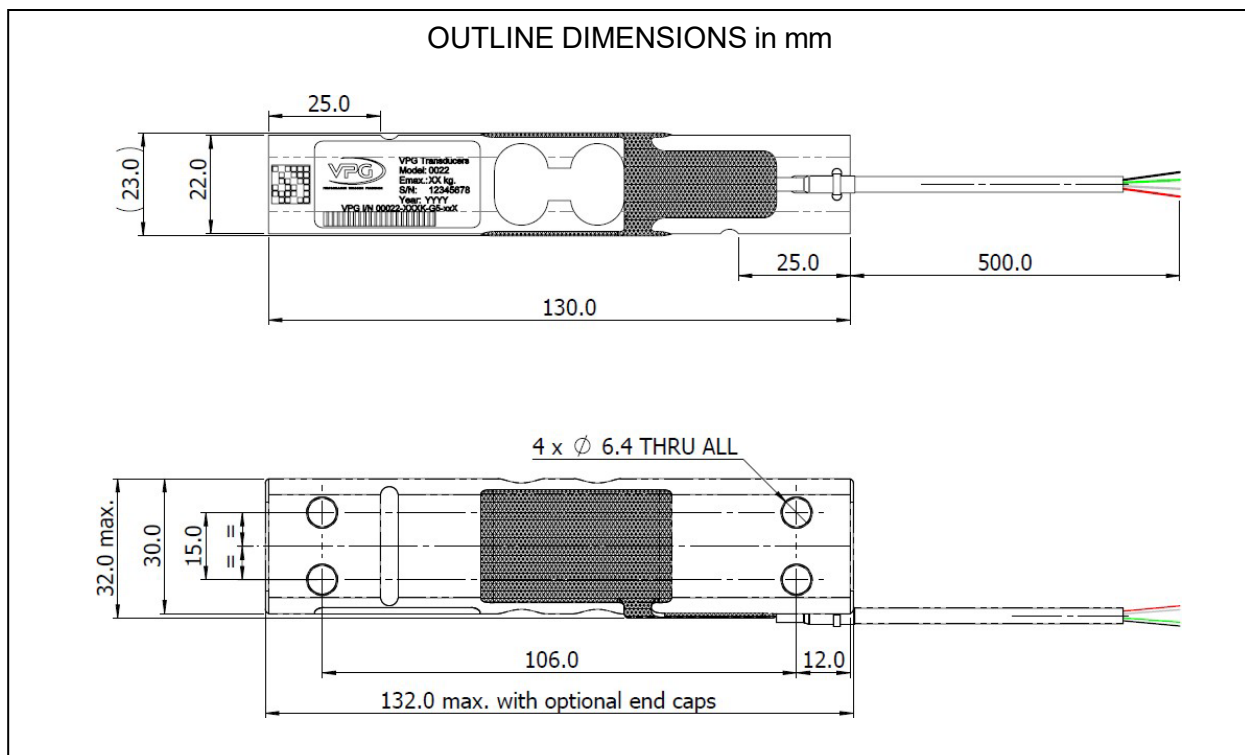

Low-Profile Aluminum Load Cell

SPECIFICATIONS					
PARAMETER	VALUE				UNIT
Rated capacity - R.C. (E_{max})	10, 15, 20, 30				kg
NTEP/OIML accuracy class ⁽¹⁾	NTEP	Non-Approved	C3 ⁽²⁾	C3MR10 ⁽³⁾	
Maximum no. of intervals _(n)	5000 single	1000	3000	3000	
$Y = E_{max}/V_{min}$	10000	2000	6000	10000	Maximum available 15000 ⁽¹⁾
Rated output - R.O.	2.0				mV/V
Rated output tolerance	0.2				±mV/V
Zero balance	0.1				±mV/V
Zero return, 30 min.	0.0100	0.0500	0.0170	0.0170	±% of applied load
Total error (per OIML R60)	0.0200	0.0200	0.0200	0.0200	±% of rated output
Temperature effect on zero	0.0014	0.0070	0.0023	0.0014	±% of rated output/°C
Temperature effect on output	0.0010	0.0030	0.0010	0.0010	±% of applied load/°C
Eccentric loading error	0.0048	0.0085	0.0057	0.0057	±% of rated load/cm
Maximum rec. platform size	35 x 35				cm
Temp. range, compensated	-10 to +40				°C
Temp. range, safe & storage	-30 to +70				°C
Maximum safe central overload	150				% of R.C.
Ultimate central overload	250				% of R.C.
Excitation, recommended	10				VDC or VAC RMS
Excitation, range	5...15				VDC or VAC RMS
Input impedance	350...445				Ω
Output impedance	349...360				Ω
Insulation resistance	>2000				MΩ @50 VDC
Cable length	0.5				m
Cable type	4 ⁽⁴⁾ wire, shielded, PVC jacket, floating shield				Standard
Construction	Anodized aluminum				
Environmental protection	IP66				
Recommended mounting torque	7.0				N*m

⁽¹⁾ OIML & NTEP approvals pending

⁽²⁾ 50% utilization

⁽³⁾ 30% utilization

⁽⁴⁾ Options: 6-wire cable

All specifications subject to change without notice.

WIRING SCHEMATIC DIAGRAM
(Balanced bridge configuration)

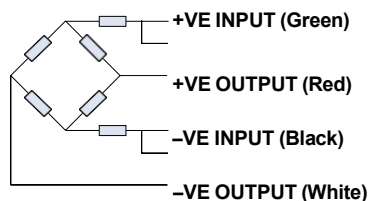

Disclaimer

ALL PRODUCTS, PRODUCT SPECIFICATIONS AND DATA ARE SUBJECT TO CHANGE WITHOUT NOTICE.

Vishay Precision Group, Inc., its affiliates, agents, and employees, and all persons acting on its or their behalf (collectively, "VPG"), disclaim any and all liability for any errors, inaccuracies or incompleteness contained herein or in any other disclosure relating to any product.

The product specifications do not expand or otherwise modify VPG's terms and conditions of purchase, including but not limited to, the warranty expressed therein.

VPG makes no warranty, representation or guarantee other than as set forth in the terms and conditions of purchase. To the maximum extent permitted by applicable law, VPG disclaims (i) any and all liability arising out of the application or use of any product, (ii) any and all liability, including without limitation special, consequential or incidental damages, and (iii) any and all implied warranties, including warranties of fitness for particular purpose, non-infringement and merchantability.

Information provided in datasheets and/or specifications may vary from actual results in different applications and performance may vary over time. Statements regarding the suitability of products for certain types of applications are based on VPG's knowledge of typical requirements that are often placed on VPG products. It is the customer's responsibility to validate that a particular product with the properties described in the product specification is suitable for use in a particular application. You should ensure you have the current version of the relevant information by contacting VPG prior to performing installation or use of the product, such as on our website at vpgsensors.com.

No license, express, implied, or otherwise, to any intellectual property rights is granted by this document, or by any conduct of VPG.

The products shown herein are not designed for use in lifesaving or life-sustaining applications unless otherwise expressly indicated. Customers using or selling VPG products not expressly indicated for use in such applications do so entirely at their own risk and agree to fully indemnify VPG for any damages arising or resulting from such use or sale. Please contact authorized VPG personnel to obtain written terms and conditions regarding products designed for such applications.

Product names and markings noted herein may be trademarks of their respective owners.

Copyright Vishay Precision Group, Inc., 2022. All rights reserved.