



Product Change Notification / SYST-28MBMZ967

Date:

31-Jul-2023

Product Category:

Clock and Timing - Oscillators

PCN Type:

Document Change

Notification Subject:

Data Sheet - DSC1001/3/4 - 1.8V-3.3V Low-Power Precision CMOS Oscillator

Affected CPNs:

[SYST-28MBMZ967_Affected_CPN_07312023.pdf](#)

[SYST-28MBMZ967_Affected_CPN_07312023.csv](#)

Notification Text:

SYST-28MBMZ967

Microchip has released a new Datasheet for the DSC1001/3/4 - 1.8V-3.3V Low-Power Precision CMOS Oscillator of devices. If you are using one of these devices please read the document located at [DSC1001/3/4 - 1.8V-3.3V Low-Power Precision CMOS Oscillator](#).

Notification Status: Final

Description of Change:

- Updated the Package Marking Information drawing.

Impacts to Data Sheet: None

Reason for Change: To Improve Productivity

Change Implementation Status: Complete

Date Document Changes Effective: 29 Jul 2023

NOTE: Please be advised that this is a change to the document only the product has not been changed.

Markings to Distinguish Revised from Unrevised Devices: N/A

Attachments:

[DSC1001/3/4 - 1.8V-3.3V Low-Power Precision CMOS Oscillator](#)

Please contact your local [Microchip sales office](#) with questions or concerns regarding this notification.

Terms and Conditions:

If you wish to receive Microchip PCNs via email please register for our PCN email service at our [PCN home page](#) select register then fill in the required fields. You will find instructions about registering for Microchips PCN email service in the [PCN FAQ](#) section.

If you wish to change your PCN profile, including opt out, please go to the [PCN home page](#) select login and sign into your myMicrochip account. Select a profile option from the left navigation bar and make the applicable selections.

Affected Catalog Part Numbers (CPN)

DSC1001DC1-004.9152
DSC1001DC1-025.0000
DSC1001DC1-027.0000
DSC1001DC1-050.0000
DSC1001DC2-004.9152
DSC1001DC2-025.0000
DSC1001DC2-027.0000
DSC1001DC5-012.0000
DSC1001DC5-024.5760
DSC1001DC5-038.8800
DSC1001DC5-040.0000
DSC1001DC5-037.4000
DSC1001DC5-012.8000
DSC1001DC1-100.0000
DSC1001CI1-001.0000
DSC1001CI1-008.0000
DSC1001CI1-012.0000
DSC1001CI1-012.2880
DSC1001CI2-028.6363
DSC1001CI1-016.0000
DSC1001CI1-019.2000
DSC1001CI1-024.0000
DSC1001CI1-025.0000
DSC1001CI1-026.0000
DSC1001CI1-027.0000
DSC1001CI1-020.0000
DSC1001CI1-033.3333
DSC1001CI1-047.3333
DSC1001CI1-048.0000
DSC1001CI1-050.0000
DSC1001CI2-002.0480
DSC1001CI2-004.0000
DSC1001CI2-008.0000
DSC1001CI2-011.0592
DSC1001CI2-012.0000
DSC1001CI2-012.2880
DSC1001CI2-014.3181
DSC1001CI2-014.7456
DSC1001CI2-016.0000
DSC1001CI2-018.0000
DSC1001CI2-018.4320
DSC1001CI2-020.0000
DSC1001CI2-022.5792
DSC1001CI2-024.0000
DSC1001CI2-024.5760
DSC1001CI2-025.0000

DSC1001CI2-027.0000
DSC1001CI2-003.5795
DSC1001CI1-007.5000
DSC1001CI2-032.7680
DSC1001CI2-033.0000
DSC1001CI2-033.3300
DSC1001CI2-033.3333
DSC1001CI2-026.0000
DSC1001CI2-037.1250
DSC1001CI2-040.0000
DSC1001CI2-048.0000
DSC1001CI2-050.0000
DSC1001CI2-060.0000
DSC1001CI2-066.6666
DSC1001CI2-074.2500
DSC1001CI2-080.0000
DSC1001CI2-100.0000
DSC1001CI5-004.9152
DSC1001CI5-010.0000
DSC1001CI5-019.2000
DSC1001CI5-020.0000
DSC1001CI5-024.0000
DSC1001CI5-025.0000
DSC1001CI5-026.0000
DSC1001CI5-032.7680
DSC1001CI5-037.1250
DSC1001CI5-040.0000
DSC1001CI5-050.0000
DSC1001CI2-054.0000
DSC1001CI5-100.0000
DSC1001CI2-125.0000
DSC1001CI5-012.0000
DSC1001CI5-008.0000
DSC1001CI5-012.2880
DSC1001CI2-096.0000
DSC1001CI5-018.4320
DSC1001CI5-016.0000
DSC1001CI5-024.5760
DSC1001CI5-027.0000
DSC1001CI5-030.0000
DSC1001CI1-003.6864
DSC1001CI2-012.5000
DSC1001CI5-009.6000
DSC1001CI1-100.0000
DSC1001CI2-006.0000
DSC1001CI5-044.0000
DSC1001CI5-019.0000
DSC1001CI5-060.0000
DSC1001CI1-033.0000

DSC1001CI5-011.0592
DSC1001CI2-031.2500
DSC1001CI2-049.1520
DSC1001CI2-032.0000
DSC1001CI5-133.3330
DSC1001CI5-070.4550
DSC1001CI2-008.1920
DSC1001CI2-010.4857
DSC1001CI2-001.9521
DSC1001CI2-007.3728
DSC1001CI2-150.0000
DSC1001CI5-009.7280
DSC1001CI5-016.3840
DSC1001CI2-133.0000
DSC1001CI5-033.3333
DSC1001CI5-032.0000
DSC1001CI5-033.0000
DSC1001CI5-033.3330
DSC1001CI2-030.0000
DSC1001CI5-048.0000
DSC1001CI5-125.0000
DSC1001CI1-010.0000
DSC1001CI1-033.3330
DSC1001CI2-072.0000
DSC1001CI2-108.0000
DSC1001CI2-028.3220
DSC1001CI2-043.0000
DSC1001CI2-019.2000
DSC1001CI2-038.4000
DSC1001CI2-052.0000
DSC1001CI2-001.9512
DSC1001CI2-033.3330
DSC1001CI5-024.3050
DSC1001CI5-033.3300
DSC1001CI5-014.3181
DSC1001CI5-026.8000
DSC1001CI2-026.8000
DSC1001CI2-010.4858
DSC1001CI1-031.9488
DSC1001CI1-004.0000
DSC1001CI5-014.7456
DSC1001CI5-008.1920
DSC1001CI2-003.0720
DSC1001CI1-080.0000
DSC1001CI5-022.0000
DSC1001CI2-100.8000
DSC1001CI5-022.5792
DSC1001CI2-024.3050
DSC1001CI1-004.0960

DSC1001CI5-003.2768
DSC1001CI5-007.3728
DSC1001CI2-003.2768
DSC1001CI3-024.0000
DSC1001CI3-025.0000
DSC1001CI3-027.0000
DSC1001CI3-013.8240
DSC1001CI5-015.0000
DSC1001CI5-144.0000
DSC1001CI5-029.4912
DSC1001CI2-133.3330
DSC1001CI3-100.0000
DSC1001CI2-074.1750
DSC1001CI5-003.6864
DSC1001CI3-003.5790
DSC1001CI1-018.4320
DSC1001CI1-040.0000
DSC1001CI2-066.0000
DSC1001CI2-026.6363
DSC1001CI1-064.0000
DSC1001CI2-003.8000
DSC1001CI3-012.0000
DSC1001CI3-033.0000
DSC1001CI1-005.0000
DSC1001CI3-019.2000
DSC1001CI3-050.0000
DSC1001CI1-004.9152
DSC1001CI2-034.0000
DSC1001CI5-037.4000
DSC1001CI2-004.0960
DSC1001CI5-037.0879
DSC1001CI2-013.0000
DSC1001CE2-074.2500
DSC1001CI1-028.6363
DSC1001CI3-013.5000
DSC1001CI1-008.1920
DSC1001CI2-038.0000
DSC1001CI3-004.0000
DSC1001CI5-013.5000
DSC1001CI2-020.7500
DSC1001CI5-013.3300
DSC1001CI2-088.0000
DSC1001CI2-020.0036
DSC1001CI2-020.0037
DSC1001CI1-014.3181
DSC1001CI1-032.0000
DSC1001CI5-099.9990
DSC1001CI2-024.9600
DSC1001CI2-029.5000

DSC1001CI1-125.0000
DSC1001CI1-003.5800
DSC1001CI5-026.6000
DSC1001CI1-001.5000
DSC1001BI1-010.0000
DSC1001BI1-032.0000
DSC1001BI1-048.0000
DSC1001BI1-050.0000
DSC1001BI1-054.0000
DSC1001BI1-060.0000
DSC1001BI1-075.0000
DSC1001BI1-027.0000
DSC1001BI2-005.5296
DSC1001BI2-012.0000
DSC1001BI2-012.2880
DSC1001BI2-016.0000
DSC1001BI2-022.8000
DSC1001BI2-024.0000
DSC1001BI2-025.0000
DSC1001BI2-040.0000
DSC1001BI5-040.0000
DSC1001BI2-033.3330
DSC1001BI2-042.5000
DSC1001BI2-048.0000
DSC1001BI2-050.0000
DSC1001BI2-008.0000
DSC1001BI2-002.0480
DSC1001BI2-100.0000
DSC1001BI2-125.0000
DSC1001BI2-133.0000
DSC1001BI5-010.0000
DSC1001BI2-024.5760
DSC1001BI5-025.0000
DSC1001BI2-007.3728
DSC1001BI2-027.0000
DSC1001BI5-050.0000
DSC1001BI5-100.0000
DSC1001BI5-125.0000
DSC1001BI1-038.4000
DSC1001BI2-148.5000
DSC1001BI5-008.0000
DSC1001BI5-016.0000
DSC1001BI5-024.0000
DSC1001BI5-032.0000
DSC1001BI1-008.0000
DSC1001BI2-018.4320
DSC1001BI5-020.0000
DSC1001BI5-133.3330
DSC1001BI1-004.0000

DSC1001BI2-030.0000
DSC1001BI2-016.3840
DSC1001BI1-012.2880
DSC1001BI1-022.1184
DSC1001BI1-024.0000
DSC1001BI1-024.5760
DSC1001BI1-025.0000
DSC1001BI1-040.0000
DSC1001BI1-125.0000
DSC1001BI2-014.7456
DSC1001BI2-020.0000
DSC1001BI2-014.3181
DSC1001BI1-020.0000
DSC1001BI5-090.0000
DSC1001BI1-066.6666
DSC1001BI2-133.3330
DSC1001BI2-012.5000
DSC1001BI5-013.5600
DSC1001BI1-100.0000
DSC1001BI1-012.0000
DSC1001BI2-033.0000
DSC1001BI2-006.0000
DSC1001BI2-026.0000
DSC1001BI5-084.0000
DSC1001BI1-033.3330
DSC1001BI2-012.2888
DSC1001BI2-004.0000
DSC1001BI2-010.0000
DSC1001BI2-013.0810
DSC1001BI2-054.0000
DSC1001BI5-014.7456
DSC1001BI2-028.6363
DSC1001BI5-033.0000
DSC1001BI2-016.9344
DSC1001BI5-027.0000
DSC1001BI1-080.0000
DSC1001BI1-019.6608
DSC1001BI5-028.6363
DSC1001BI5-001.6000
DSC1001BI1-001.8432
DSC1001BI5-125.0031
DSC1001BI1-011.0592
DSC1001BI5-080.0000
DSC1001BI1-026.0000
DSC1001BI3-024.0000
DSC1001BI3-012.0000
DSC1001BI5-018.4320
DSC1001BI2-029.4912
DSC1001BI3-033.0000

DSC1001BI3-050.0000
DSC1001BI2-001.5440
DSC1001BI1-033.0000
DSC1001BI1-133.0000
DSC1001BI2-011.0592
DSC1001BI5-019.6800
DSC1001BI1-003.6864
DSC1001BI2-003.1250
DSC1001BI5-066.6660
DSC1001BI1-099.0000
DSC1001BI2-099.0000
DSC1001BI5-040.9600
DSC1001BI2-003.6864
DSC1001BI3-020.0000
DSC1001BI2-040.6800
DSC1001BI2-033.3300
DSC1001DI1-001.8432
DSC1001DI1-003.6864
DSC1001DI1-005.0000
DSC1001DI1-004.0000
DSC1001DI1-010.0000
DSC1001DI1-012.0000
DSC1001DI1-013.3333
DSC1001DI1-014.7456
DSC1001DI1-016.3840
DSC1001DI1-020.0000
DSC1001DI1-024.0000
DSC1001DI1-008.0000
DSC1001DI1-025.0000
DSC1001DI1-026.0000
DSC1001DI1-024.5760
DSC1001DI1-033.3300
DSC1001DI1-033.3330
DSC1001DI1-033.3333
DSC1001DI1-048.0000
DSC1001DI1-050.0000
DSC1001DI1-072.0000
DSC1001DI1-098.3040
DSC1001DI1-100.0000
DSC1001DI1-125.0000
DSC1001DI1-133.0000
DSC1001DI2-001.0000
DSC1001DI2-003.6864
DSC1001DI2-005.0196
DSC1001DI2-005.3125
DSC1001DI2-008.0000
DSC1001DI2-009.6000
DSC1001DI2-012.0000
DSC1001DI2-014.7456

DSC1001DI2-016.0000
DSC1001DI2-019.2000
DSC1001DI2-020.0000
DSC1001DI2-024.0000
DSC1001DI2-024.5760
DSC1001DI2-025.0000
DSC1001DI2-026.0000
DSC1001DI2-027.0000
DSC1001DI2-032.0000
DSC1001DI2-033.3300
DSC1001DI2-033.3333
DSC1001DI2-037.1250
DSC1001DI2-022.0000
DSC1001DI2-038.4000
DSC1001DI2-048.0000
DSC1001DI2-024.5455
DSC1001DI2-050.0000
DSC1001DI2-066.6600
DSC1001DI2-022.5792
DSC1001DI2-080.0000
DSC1001DI2-086.4000
DSC1001DI2-100.0000
DSC1001DI2-125.0000
DSC1001DI2-040.0000
DSC1001DI5-002.4576
DSC1001DI5-007.3728
DSC1001DI5-012.0000
DSC1001DI5-016.0000
DSC1001DI5-019.2000
DSC1001DI5-020.0000
DSC1001DI5-025.0000
DSC1001DI5-026.0000
DSC1001DI5-027.0000
DSC1001DI2-072.0000
DSC1001DI2-074.2500
DSC1001DI5-032.2500
DSC1001DI5-033.3333
DSC1001DI5-038.4000
DSC1001DI5-100.0000
DSC1001DI5-125.0000
DSC1001DI5-133.0000
DSC1001DI5-150.0000
DSC1001DI5-002.0480
DSC1001DI2-047.3885
DSC1001DI1-038.4000
DSC1001DI2-026.6000
DSC1001DI1-066.0000
DSC1001DI5-008.0000
DSC1001DI5-047.3885

DSC1001DI5-013.3333
DSC1001DI5-022.5792
DSC1001DI5-030.0000
DSC1001DI2-024.5454
DSC1001DI2-029.5000
DSC1001DI5-033.0000
DSC1001DI1-033.0000
DSC1001DI1-030.0000
DSC1001DI5-004.0000
DSC1001DI1-032.0000
DSC1001DI2-028.6363
DSC1001DI2-031.2500
DSC1001DI1-012.8000
DSC1001DI5-010.0000
DSC1001DI1-019.2000
DSC1001DI5-024.0000
DSC1001DI5-024.5760
DSC1001DI5-033.3330
DSC1001DI5-001.8432
DSC1001DI2-018.0000
DSC1001DI5-044.0000
DSC1001DI5-048.0000
DSC1001DI5-050.0000
DSC1001DI5-060.0000
DSC1001DI5-075.0000
DSC1001DI5-080.0000
DSC1001DI1-074.2500
DSC1001DL5-032.0000
DSC1001DI1-054.0000
DSC1001DI1-027.0000
DSC1001DI2-054.0000
DSC1001DI5-047.3385
DSC1001DI1-060.0000
DSC1001DI2-006.7800
DSC1001DI2-004.0960
DSC1001DI2-030.0000
DSC1001DI2-001.8432
DSC1001DL2-001.8432
DSC1001DI2-066.0000
DSC1001DI5-133.3330
DSC1001DI5-018.4320
DSC1001DI1-018.4320
DSC1001DI2-004.0000
DSC1001DI1-004.9152
DSC1001DI2-045.1584
DSC1001DI2-049.1520
DSC1001DI2-011.0592
DSC1001DI2-032.7680
DSC1001DI1-016.6666

DSC1001DI5-087.0655
DSC1001DI1-045.1584
DSC1001DI5-025.6000
DSC1001DI1-045.5840
DSC1001DI1-013.3300
DSC1001DI2-003.0720
DSC1001DI2-057.2727
DSC1001DI2-096.0000
DSC1001DI2-023.0000
DSC1001DI5-054.0000
DSC1001DI1-029.4912
DSC1001DI5-013.5288
DSC1001DI1-007.3728
DSC1001DI1-080.0000
DSC1001DI1-002.0000
DSC1001DI2-064.0000
DSC1001DI3-024.0000
DSC1001DI5-032.7680
DSC1001DI1-011.0592
DSC1001DI3-012.0000
DSC1001DI2-033.0000
DSC1001DI5-011.0592
DSC1001DI2-133.0000
DSC1001DI2-002.0970
DSC1001DI3-100.0000
DSC1001DI3-133.0000
DSC1001DI1-064.0000
DSC1001DI5-019.6800
DSC1001DI1-025.0008
DSC1001DI5-090.0000
DSC1001DI5-014.3181
DSC1001DI1-116.6666
DSC1001DI2-066.6670
DSC1001DI5-009.2160
DSC1001DI2-060.0000
DSC1001DI5-005.0196
DSC1001DI5-037.4000
DSC1001DI1-028.6363
DSC1001DI3-012.2880
DSC1001DI3-040.0000
DSC1001DI2-070.0000
DSC1001DI3-060.0000
DSC1001DI5-057.5580
DSC1001DI1-036.0000
DSC1001DI1-038.0000
DSC1001DI5-030.7200
DSC1001DI3-027.0000
DSC1001DI2-014.3181
DSC1001DI5-040.0000

DSC1001DI1-069.1200
DSC1001DI5-032.4000
DSC1001DI5-041.1420
DSC1001DI5-014.7456
DSC1001AI1-005.0000
DSC1001AI1-012.2880
DSC1001AI2-006.0000
DSC1001AI2-012.0000
DSC1001AI1-025.0000
DSC1001AI2-014.7456
DSC1001AI2-024.0000
DSC1001AI2-025.0000
DSC1001AI2-008.0000
DSC1001AI2-033.3333
DSC1001AI2-048.0000
DSC1001AI2-050.0000
DSC1001AI2-054.0000
DSC1001AI2-080.0000
DSC1001AI2-083.3330
DSC1001AI2-100.0000
DSC1001AI2-125.0000
DSC1001AI2-016.0000
DSC1001AI5-002.4576
DSC1001AI2-025.0007
DSC1001AI2-026.0000
DSC1001AI2-032.0000
DSC1001AI2-014.3180
DSC1001AI5-025.0000
DSC1001AI5-072.0000
DSC1001AI5-144.0000
DSC1001AI5-150.0000
DSC1001AI2-120.0000
DSC1001AI5-008.0000
DSC1001AI5-011.0592
DSC1001AI5-012.0000
DSC1001AI5-016.0000
DSC1001AI3-029.4912
DSC1001AI5-027.0000
DSC1001AI5-029.4912
DSC1001AI5-033.3330
DSC1001AI5-048.0000
DSC1001AI5-080.0000
DSC1001AI5-100.0000
DSC1001AI5-125.0000
DSC1001AI5-125.0060
DSC1001AI2-066.6600
DSC1001AI2-066.6670
DSC1001AI1-055.3330
DSC1001AI5-032.0000

DSC1001AI2-096.0000
DSC1001AI5-033.0000
DSC1001AI2-001.0000
DSC1001AI2-064.0000
DSC1001AI5-070.6760
DSC1001AI1-050.0000
DSC1001AI2-010.0000
DSC1001AI2-027.0000
DSC1001AI2-011.7000
DSC1001AI2-012.3667
DSC1001AI5-040.0000
DSC1001AI5-024.0000
DSC1001AI1-033.0000
DSC1001AI2-040.0000
DSC1001AI1-049.1520
DSC1001AI5-012.2880
DSC1001AI1-016.0000
DSC1001AI1-001.0000
DSC1001AI5-066.0000
DSC1001AI1-066.0000
DSC1001AI1-020.0000
DSC1001AI1-013.1072
DSC1001AI1-024.5760
DSC1001AI1-030.0000
DSC1001AI5-050.0000
DSC1001AI1-008.0000
DSC1001AI1-032.7680
DSC1001AI2-002.0480
DSC1001AI1-033.3333
DSC1001AI2-065.5360
DSC1001AI2-032.7680
DSC1001AI1-003.5700
DSC1001AI5-028.6363
DSC1001AI2-075.0000
DSC1001AI2-150.0000
DSC1001AI1-007.3728
DSC1001AI1-004.9152
DSC1001AI1-012.0000
DSC1001AI2-033.3330
DSC1001AI5-016.3840
DSC1001AI5-010.0000
DSC1001AI5-106.2500
DSC1001AI1-014.3182
DSC1001AI3-025.0000
DSC1001AI3-030.0000
DSC1001AI1-033.3330
DSC1001AI1-024.5450
DSC1001AI5-001.7000
DSC1001AI5-014.7456

DSC1001AI2-029.4912
DSC1001AI3-100.0000
DSC1001AI1-075.0000
DSC1001AI2-129.6000
DSC1001AI3-040.0000
DSC1001AI2-066.6666
DSC1001AI1-029.4912
DSC1001AI5-002.0480
DSC1001AI1-026.0000
DSC1001AI1-016.3840
DSC1001AI1-032.0000
DSC1001AI5-003.6864
DSC1001CE1-004.0000
DSC1001CE1-012.2880
DSC1001CE1-012.0000
DSC1001CE1-014.3182
DSC1001CE1-019.6608
DSC1001CE1-024.0000
DSC1001CE1-024.5760
DSC1001CE1-025.0000
DSC1001CE1-033.8688
DSC1001CE1-037.1250
DSC1001CE1-060.0000
DSC1001CE1-064.8000
DSC1001CE1-069.2480
DSC1001CE2-001.8432
DSC1001CE2-006.0000
DSC1001CE2-010.0000
DSC1001CE2-020.0000
DSC1001CE2-024.0000
DSC1001CE2-024.5760
DSC1001CE2-025.0000
DSC1001CE2-027.0000
DSC1001CE2-034.0000
DSC1001CE2-040.0000
DSC1001CE2-048.0000
DSC1001CE2-050.0000
DSC1001CL1-001.8432
DSC1001CL1-016.0000
DSC1001CL1-020.0000
DSC1001CL1-025.0000
DSC1001CL1-030.0000
DSC1001CL1-032.0000
DSC1001CE2-100.0000
DSC1001CL1-066.0000
DSC1001CL1-125.0000
DSC1001CL2-009.5290
DSC1001CL2-012.0000
DSC1001CL2-020.0000

DSC1001CL2-022.5972
DSC1001CL2-024.0000
DSC1001CL2-025.0000
DSC1001CL1-033.0000
DSC1001CL2-027.0000
DSC1001CL2-033.3333
DSC1001CL2-037.1250
DSC1001CL2-050.0000
DSC1001CL2-004.0000
DSC1001CL5-020.0000
DSC1001CL5-025.0000
DSC1001CL5-026.0000
DSC1001CL5-027.0000
DSC1001CL5-027.1200
DSC1001CL5-032.0000
DSC1001CL5-033.3330
DSC1001CL5-040.0000
DSC1001CL5-125.0000
DSC1001CL5-008.0000
DSC1001CL5-150.0000
DSC1001CL5-28.63636
DSC1001CL5-012.0000
DSC1001CL5-024.0000
DSC1001CL5-050.0000
DSC1001CL5-033.0000
DSC1001CL5-060.0000
DSC1001CL5-114.0000
DSC1001CL1-100.0000
DSC1001CL5-014.7456
DSC1001CL5-016.0000
DSC1001CL5-014.3181
DSC1001CL5-010.0000
DSC1001CE1-125.0000
DSC1001CE5-148.0000
DSC1001CE2-032.1100
DSC1001CE1-022.1184
DSC1001CL2-040.0000
DSC1001CL5-080.0000
DSC1001CL5-100.0000
DSC1001CE2-012.2880
DSC1001CE2-003.5800
DSC1001CL1-001.6000
DSC1001CE1-027.0000
DSC1001CE5-148.5000
DSC1001CE2-022.5792
DSC1001CL1-033.3333
DSC1001CL1-048.0000
DSC1001CE1-066.6666
DSC1001CE2-012.0000

DSC1001CL1-024.0000
DSC1001CL2-030.0000
DSC1001CE1-019.2000
DSC1001CL1-003.2500
DSC1001CL2-008.0000
DSC1001CL2-025.5760
DSC1001CE1-083.3300
DSC1001CE2-032.0000
DSC1001CE1-050.0000
DSC1001CL5-006.7700
DSC1001CL5-006.7900
DSC1001CL5-013.5400
DSC1001CL5-013.5800
DSC1001CL5-050.3500
DSC1001CL5-001.6000
DSC1001CL5-025.6000
DSC1001CL5-011.0592
DSC1001CE2-018.4320
DSC1001CL5-012.8000
DSC1001CL2-100.0000
DSC1001CL2-054.0000
DSC1001CE5-016.0000
DSC1001CE1-008.0000
DSC1001CE5-025.0000
DSC1001CL5-048.0000
DSC1001CE1-080.0000
DSC1001CE1-033.3300
DSC1001CL2-024.5760
DSC1001CL1-050.0000
DSC1001CL2-014.7456
DSC1001CL2-148.5000
DSC1001CL2-016.0000
DSC1001CE5-012.2880
DSC1001CL5-016.3840
DSC1001CE5-002.0000
DSC1001CE5-008.0000
DSC1001CE1-026.0000
DSC1001CL2-032.0000
DSC1001CL2-033.3300
DSC1001CL5-004.0000
DSC1001CE1-033.3333
DSC1001CL5-075.0000
DSC1001CL5-018.4320
DSC1001CL3-012.2880
DSC1001CL5-029.4912
DSC1001CL2-064.0000
DSC1001CL2-003.1250
DSC1001CL2-029.4912
DSC1001CL2-066.6660

DSC1001CL2-125.0000
DSC1001CL5-003.6864
DSC1001CL3-080.0000
DSC1001CL3-033.0000
DSC1001CE1-004.0960
DSC1001CL5-044.0000
DSC1001CL1-016.6400
DSC1001CE1-100.0000
DSC1001CE1-110.0000
DSC1001CE1-032.0000
DSC1001CL3-024.0000
DSC1001CL3-072.0000
DSC1001CE2-019.2000
DSC1001CE2-108.0000
DSC1001CE3-005.0000
DSC1001CL2-048.0000
DSC1001CL2-090.0000
DSC1001CE2-064.0000
DSC1001CL3-008.0000
DSC1001CL1-012.0000
DSC1001CL2-022.5792
DSC1001CL5-007.3728
DSC1001CL5-028.0000
DSC1001CL1-008.0000
DSC1001CL2-026.0000
DSC1001CL5-064.0000
DSC1001CE2-013.5600
DSC1001CE5-032.2123
DSC1001CE1-048.0000
DSC1001CL2-006.0052
DSC1001CL1-040.0000
DSC1001CL1-006.0053
DSC1001CL3-025.0000
DSC1001CL2-006.0053
DSC1001CE2-033.3333
DSC1001CL3-040.0000
DSC1001CE2-060.0000
DSC1001CL1-002.0000
DSC1001CE1-007.3728
DSC1001CE1-006.1760
DSC1001CE1-008.1920
DSC1001CL1-076.0000
DSC1001BE1-025.0000
DSC1001BE1-040.0000
DSC1001BE1-048.0000
DSC1001BE1-024.0000
DSC1001BE1-125.0000
DSC1001BE2-024.0000
DSC1001BE2-025.0000

DSC1001BE2-027.0000
DSC1001BE2-033.3330
DSC1001BE2-050.0000
DSC1001BE2-100.0000
DSC1001BL1-002.1760
DSC1001BL2-050.0000
DSC1001BL5-010.0000
DSC1001BL5-100.0000
DSC1001BL5-025.0000
DSC1001BL2-025.0000
DSC1001BL5-050.0000
DSC1001BL5-016.0000
DSC1001BL5-080.0000
DSC1001BE1-050.0000
DSC1001BE5-022.5792
DSC1001BE2-001.6000
DSC1001BE1-012.0000
DSC1001BE2-010.0000
DSC1001BL5-095.0000
DSC1001BL1-016.0000
DSC1001BE5-064.0000
DSC1001BL5-064.0000
DSC1001BL2-020.0000
DSC1001BL1-060.0000
DSC1001BE2-012.2880
DSC1001BE2-014.7450
DSC1001BE1-001.8432
DSC1001BE1-026.0000
DSC1001BE2-048.0000
DSC1001BE1-014.3182
DSC1001BE1-014.7456
DSC1001BE2-014.7456
DSC1001BE1-133.0000
DSC1001BL5-001.1385
DSC1001BL5-001.1386
DSC1001BL5-001.1387
DSC1001BL5-001.1388
DSC1001BL5-001.1389
DSC1001BL5-108.0000
DSC1001BE5-020.0000
DSC1001BL5-033.3330
DSC1001BL5-026.7000
DSC1001BL5-026.6500
DSC1001BE5-016.0000
DSC1001BL2-048.0000
DSC1001BL2-026.0000
DSC1001BL5-026.0000
DSC1001BL5-120.0000
DSC1001BL5-014.7456

DSC1001BL5-033.0000
DSC1001BE2-090.0000
DSC1001BL2-024.0000
DSC1001BL5-125.0000
DSC1001BE5-024.0000
DSC1001BL5-030.0000
DSC1001BE1-066.6666
DSC1001BL5-049.5000
DSC1001BE1-001.4850
DSC1001BL5-072.0000
DSC1001BL5-066.0000
DSC1001BL3-001.0000
DSC1001BE5-033.3330
DSC1001BL5-075.0000
DSC1001BL5-004.0000
DSC1001BE5-012.0000
DSC1001BE3-026.0000
DSC1001BL5-058.9824
DSC1001BE1-060.0000
DSC1001BE3-022.1184
DSC1001BL5-032.0000
DSC1001BE5-030.6400
DSC1001BL5-106.2500
DSC1001BL2-125.0000
DSC1001BE1-004.0625
DSC1001BE1-004.0960
DSC1001BL2-012.0000
DSC1001BE5-027.0000
DSC1001BE5-030.0000
DSC1001BE1-033.3333
DSC1001BL2-012.5000
DSC1001DE1-018.4320
DSC1001DE1-019.6608
DSC1001DE1-024.0000
DSC1001DE1-027.0000
DSC1001DE1-048.0000
DSC1001DE1-074.2500
DSC1001DE1-100.0000
DSC1001DE1-125.0000
DSC1001DE2-016.0000
DSC1001DE2-050.0000
DSC1001DE2-032.0000
DSC1001DE5-016.0000
DSC1001DE5-019.2000
DSC1001DL1-008.0000
DSC1001DE2-024.0000
DSC1001DL1-027.0000
DSC1001DL1-025.0000
DSC1001DL2-001.0000

DSC1001DL2-001.4850
DSC1001DL2-008.0000
DSC1001DL2-012.0000
DSC1001DL2-013.5600
DSC1001DL2-020.0000
DSC1001DL2-024.0000
DSC1001DL2-025.0000
DSC1001DL2-027.0000
DSC1001DL2-030.0000
DSC1001DL2-033.3333
DSC1001DL2-032.0000
DSC1001DL5-001.0000
DSC1001DL5-001.8432
DSC1001DL5-002.0000
DSC1001DL2-050.0000
DSC1001DL5-008.0000
DSC1001DL5-007.3728
DSC1001DL5-016.0000
DSC1001DL5-010.0000
DSC1001DL5-020.0000
DSC1001DL5-024.0000
DSC1001DL5-025.0000
DSC1001DL5-027.0000
DSC1001DL5-030.0000
DSC1001DL5-031.2500
DSC1001DL5-054.0000
DSC1001DL5-026.0000
DSC1001DL5-100.0000
DSC1001DL5-033.0000
DSC1001DL5-048.0000
DSC1001DL5-050.0000
DSC1001DL5-015.3600
DSC1001DL5-125.0000
DSC1001DL5-080.0000
DSC1001DE2-020.0000
DSC1001DE1-012.0000
DSC1001DL5-010.2000
DSC1001DL2-037.1250
DSC1001DE1-040.0000
DSC1001DE1-050.0000
DSC1001DL2-150.0000
DSC1001DL5-011.0592
DSC1001DL2-090.0000
DSC1001DL5-012.0000
DSC1001DL5-004.0000
DSC1001DE1-025.0000
DSC1001DL5-133.3330
DSC1001DL1-010.0000
DSC1001DL5-019.2000

DSC1001DL5-033.3330
DSC1001DL5-075.0000
DSC1001DL2-072.0000
DSC1001DL2-087.0655
DSC1001DL2-049.5000
DSC1001DE5-018.4320
DSC1001DL1-080.0000
DSC1001DL2-003.9000
DSC1001DL2-013.5000
DSC1001DL2-074.2500
DSC1001DL5-128.0000
DSC1001DL1-024.0000
DSC1001DL5-024.5760
DSC1001DL2-040.0000
DSC1001DL1-001.8432
DSC1001DL1-033.3333
DSC1001DE1-075.0000
DSC1001DE2-100.0000
DSC1001DL2-016.0000
DSC1001DL1-025.2000
DSC1001DE1-033.3333
DSC1001DL5-040.0000
DSC1001DE1-019.2000
DSC1001DL2-007.3728
DSC1001DL5-072.0000
DSC1001DL5-012.2880
DSC1001DE2-038.4000
DSC1001DE1-013.0000
DSC1001DL2-012.2880
DSC1001DL2-125.0000
DSC1001DL2-004.0000
DSC1001DL1-016.0000
DSC1001DL2-023.0000
DSC1001DE1-020.0000
DSC1001DL2-026.6500
DSC1001DL5-014.3181
DSC1001DE2-008.0000
DSC1001DE2-012.0000
DSC1001DE2-027.0000
DSC1001DE2-025.0000
DSC1001DL5-016.7722
DSC1001DL2-048.0000
DSC1001DL2-066.6700
DSC1001DE1-024.3050
DSC1001DL2-002.0000
DSC1001DL1-004.0960
DSC1001DL2-049.1520
DSC1001DL2-045.1584
DSC1001DE5-037.4000

DSC1001DL5-096.0000
DSC1001DL2-066.0000
DSC1001DE5-012.0000
DSC1001DL2-026.0000
DSC1001DL2-019.2000
DSC1001DL1-012.5000
DSC1001DL2-054.0000
DSC1001DL3-027.0000
DSC1001DL3-024.0000
DSC1001DL5-016.3840
DSC1001DL2-016.3690
DSC1001DL2-061.2500
DSC1001DL5-018.4320
DSC1001DL5-033.3333
DSC1001DL2-003.6864
DSC1001DL5-003.6864
DSC1001DE2-001.0000
DSC1001DE2-090.0000
DSC1001DE2-022.0000
DSC1001DL5-037.1250
DSC1001DL5-150.0000
DSC1001DL2-033.3300
DSC1001DE5-025.0000
DSC1001DE1-024.5760
DSC1001DL5-047.0016
DSC1001DL1-005.0196
DSC1001DL2-005.0196
DSC1001DL5-005.0196
DSC1001DE3-080.0000
DSC1001DL1-150.0000
DSC1001DE3-008.0000
DSC1001DE5-150.0000
DSC1001DL1-050.0000
DSC1001DE5-049.1520
DSC1001DE5-045.1584
DSC1001DL1-040.0000
DSC1001DL5-064.0000
DSC1001DL5-028.6363
DSC1001DL5-006.0000
DSC1001DL1-033.3330
DSC1001DL5-029.4912
DSC1001DL1-004.0000
DSC1001DL2-100.0000
DSC1001DL5-032.4000
DSC1001DL5-049.5000
DSC1001DL2-012.5000
DSC1001DE2-120.0000
DSC1001DL1-033.3300
DSC1001DL5-006.4000

DSC1001DL5-026.5980
DSC1001DL5-120.0000
DSC1001DL5-087.0655
DSC1001AE1-016.6667
DSC1001AE1-033.3333
DSC1001AE1-025.0000
DSC1001AE1-033.0000
DSC1001AE1-048.0000
DSC1001AE1-050.0000
DSC1001AE1-125.0000
DSC1001AE1-133.0000
DSC1001AE2-100.0000
DSC1001AE2-125.0000
DSC1001AL2-027.0000
DSC1001AL5-007.3728
DSC1001AL5-012.0000
DSC1001AL5-016.0000
DSC1001AL5-004.0000
DSC1001AL5-024.5760
DSC1001AL5-025.0000
DSC1001AL5-016.3840
DSC1001AL5-018.4320
DSC1001AL5-080.0000
DSC1001AL5-100.0000
DSC1001AL5-032.0000
DSC1001AL5-040.0000
DSC1001AL5-050.0000
DSC1001AE1-066.6660
DSC1001AL5-001.8432
DSC1001AE1-019.6608
DSC1001AE1-024.0000
DSC1001AL5-060.0000
DSC1001AL5-125.0000
DSC1001AE2-002.0480
DSC1001AL5-024.0000
DSC1001AE5-024.5760
DSC1001AE1-027.0000
DSC1001AL5-033.0000
DSC1001AL5-033.3333
DSC1001AE1-055.0000
DSC1001AL5-048.0000
DSC1001AL5-008.0000
DSC1001AE1-006.1440
DSC1001AE1-111.0000
DSC1001AL5-027.0000
DSC1001AE1-014.3182
DSC1001AE1-024.5761
DSC1001AE1-003.6864
DSC1001AE1-054.0000

DSC1001AE5-040.0000
DSC1001AL5-066.0000
DSC1001AE1-018.1059
DSC1001AL5-030.0000
DSC1001AE1-049.1520
DSC1001AL1-001.0000
DSC1001AL1-048.0000
DSC1001AL5-016.7772
DSC1001AE2-148.5000
DSC1001AE2-048.0000
DSC1001AE5-022.5792
DSC1001AE1-001.4850
DSC1001AL2-016.0000
DSC1001AE2-080.0000
DSC1001AL1-020.0000
DSC1001AE1-004.0000
DSC1001AE1-099.0000
DSC1001AE1-098.0000
DSC1001AL2-025.0000
DSC1001AE5-004.0000
DSC1001AE5-020.0000
DSC1001AE5-125.0000
DSC1001AE5-012.0000
DSC1001AE1-010.0000
DSC1001AL5-001.0000
DSC1001AE2-050.0000
DSC1001AE2-054.0000
DSC1001AE5-029.1621
DSC1001AE5-031.6440
DSC1001AL5-011.0592
DSC1001AL1-050.0000
DSC1001AL5-010.0000
DSC1001AL5-133.3330
DSC1001AL2-020.0000
DSC1001AL2-060.0000
DSC1001AE3-013.5600
DSC1001AE1-064.0000
DSC1001AE1-040.0000
DSC1001AL5-014.7456
DSC1001AE5-017.1776
DSC1001AE5-001.2000
DSC1001AL2-029.4912
DSC1001AL2-050.0000
DSC1001AE1-003.5700
DSC1001AL5-033.3330
DSC1001AL2-024.0000
DSC1001AL2-125.0000
DSC1001AL1-025.0000
DSC1001AL1-027.0000

DSC1001AL2-100.0000
DSC1001AL5-029.4912
DSC1001CE1-004.0000T
DSC1001CE1-006.0000T
DSC1001CE1-012.0000T
DSC1001CE1-012.2880T
DSC1001CE1-015.3600T
DSC1001CE1-016.5000T
DSC1001CE1-020.0000T
DSC1001CE1-020.8300T
DSC1001CE1-024.0000T
DSC1001CE1-024.5760T
DSC1001CE1-025.0000T
DSC1001CE2-001.8432T
DSC1001CE1-033.8688T
DSC1001CE1-048.0000T
DSC1001CE2-024.0000T
DSC1001CE1-069.2480T
DSC1001CE1-086.5600T
DSC1001CE2-025.0000T
DSC1001CE2-011.2896T
DSC1001CE2-050.0000T
DSC1001CE2-026.0000T
DSC1001CE2-027.0000T
DSC1001CE2-032.1100T
DSC1001CE2-033.0000T
DSC1001CL1-020.0000T
DSC1001CE2-037.1250T
DSC1001CE2-040.0000T
DSC1001CL1-016.0000T
DSC1001CL1-025.0000T
DSC1001CE2-054.0000T
DSC1001CE2-074.2500T
DSC1001CE2-100.0000T
DSC1001CL1-125.0000T
DSC1001CL2-012.0000T
DSC1001CL2-020.0000T
DSC1001CL2-022.5972T
DSC1001CL1-030.0000T
DSC1001CL1-033.0000T
DSC1001CL2-037.1250T
DSC1001CL2-033.3333T
DSC1001CL1-066.0000T
DSC1001CL2-050.0000T
DSC1001CL2-004.0000T
DSC1001CL2-025.0000T
DSC1001CL2-027.0000T
DSC1001CL2-033.3000T
DSC1001CL5-040.0000T

DSC1001CL5-001.8432T
DSC1001CL5-008.0000T
DSC1001CL5-150.0000T
DSC1001CL5-012.0000T
DSC1001CL5-019.2000T
DSC1001CL5-020.0000T
DSC1001CL5-024.0000T
DSC1001CL5-024.5760T
DSC1001CL5-025.0000T
DSC1001CL5-026.0000T
DSC1001CL5-027.0000T
DSC1001CL5-030.0000T
DSC1001CL5-032.0000T
DSC1001CL5-033.3330T
DSC1001CL5-050.0000T
DSC1001CL5-033.0000T
DSC1001CL5-060.0000T
DSC1001CE1-037.1250T
DSC1001CL5-114.0000T
DSC1001CL1-100.0000T
DSC1001CL5-014.7456T
DSC1001CL5-016.0000T
DSC1001CL5-014.3181T
DSC1001CL5-010.0000T
DSC1001CE1-125.0000T
DSC1001CE1-022.1184T
DSC1001CL5-080.0000T
DSC1001CL5-100.0000T
DSC1001CL5-125.0000T
DSC1001CL5-133.3330T
DSC1001CL5-012.0000TABR
DSC1001CL1-001.8432T
DSC1001CE2-012.2880T
DSC1001CE2-003.5800T
DSC1001CL1-001.6000T
DSC1001CE1-027.0000T
DSC1001CL2-024.0000T
DSC1001CE5-148.5000T
DSC1001CE1-014.3182T
DSC1001CE2-022.5792T
DSC1001CL1-033.3333T
DSC1001CL1-048.0000T
DSC1001CE1-066.6666T
DSC1001CE2-012.0000T
DSC1001CL1-024.0000T
DSC1001CL2-030.0000T
DSC1001CE1-019.2000T
DSC1001CL1-003.2500T
DSC1001CL2-008.0000T

DSC1001CL2-025.5760T
DSC1001CE1-083.3300T
DSC1001CE2-032.0000T
DSC1001CE1-050.0000T
DSC1001CL5-006.7700T
DSC1001CL5-006.7900T
DSC1001CL5-013.5400T
DSC1001CL5-013.5800T
DSC1001CL5-050.3500T
DSC1001CL5-001.6000T
DSC1001CL5-025.6000T
DSC1001CL5-011.0592T
DSC1001CE2-018.4320T
DSC1001CL5-012.8000T
DSC1001CL2-100.0000T
DSC1001CL2-054.0000T
DSC1001CE5-016.0000T
DSC1001CE1-008.0000T
DSC1001CE5-025.0000T
DSC1001CL5-048.0000T
DSC1001CE1-080.0000T
DSC1001CE1-033.3300T
DSC1001CL2-024.5760T
DSC1001CL1-050.0000T
DSC1001CL2-014.7456T
DSC1001CL2-148.5000T
DSC1001CL2-016.0000T
DSC1001CE5-012.2880T
DSC1001CL5-016.3840T
DSC1001CE5-002.0000T
DSC1001CE5-008.0000T
DSC1001CE1-026.0000T
DSC1001CL2-032.0000T
DSC1001CL2-033.3300T
DSC1001CL5-004.0000T
DSC1001CE1-033.3333T
DSC1001CL5-075.0000T
DSC1001CL5-018.4320T
DSC1001CL3-012.2880T
DSC1001CL5-029.4912T
DSC1001CL2-064.0000T
DSC1001CL2-003.1250T
DSC1001CL2-029.4912T
DSC1001CL2-066.6660T
DSC1001CL2-125.0000T
DSC1001CL5-003.6864T
DSC1001CL3-080.0000T
DSC1001CL3-033.0000T
DSC1001CE1-004.0960T

DSC1001CL5-044.0000T
DSC1001CL1-016.6400T
DSC1001CE1-100.0000T
DSC1001CE1-110.0000T
DSC1001CE1-032.0000T
DSC1001CL3-024.0000T
DSC1001CL3-072.0000T
DSC1001CE2-019.2000T
DSC1001CE2-108.0000T
DSC1001CE3-005.0000T
DSC1001CL2-048.0000T
DSC1001CL2-090.0000T
DSC1001CE2-064.0000T
DSC1001CL3-008.0000T
DSC1001CL1-012.0000T
DSC1001CL2-022.5792T
DSC1001CL5-007.3728T
DSC1001CL5-028.0000T
DSC1001CL1-008.0000T
DSC1001CL2-026.0000T
DSC1001CL5-064.0000T
DSC1001CE2-013.5600T
DSC1001CE5-032.2123T
DSC1001CL2-006.0052T
DSC1001CL1-040.0000T
DSC1001CL1-006.0053T
DSC1001CL3-025.0000T
DSC1001CL2-006.0053T
DSC1001CE2-033.3333T
DSC1001CL3-040.0000T
DSC1001CE2-060.0000T
DSC1001CL1-002.0000T
DSC1001CE1-007.3728T
DSC1001CE1-006.1760T
DSC1001CE1-008.1920T
DSC1001CL1-076.0000T
DSC1001CL1-016.0000TV11
DSC1001BE1-016.0000T
DSC1001BE1-024.0000T
DSC1001BE1-025.0000T
DSC1001BE1-048.0000T
DSC1001BE1-050.0000T
DSC1001BE1-125.0000T
DSC1001BE1-133.3300T
DSC1001BE2-012.0000T
DSC1001BE2-125.0000T
DSC1001BL1-027.0000T
DSC1001BL1-048.0000T
DSC1001BL2-027.0000T

DSC1001BL2-050.0000T
DSC1001BL5-008.0000T
DSC1001BL5-010.0000T
DSC1001BL5-012.0000T
DSC1001BE2-024.0000T
DSC1001BL5-024.0000T
DSC1001BL5-024.5760T
DSC1001BL5-025.0000T
DSC1001BL5-040.0000T
DSC1001BL5-048.0000T
DSC1001BL5-066.6666T
DSC1001BL5-100.0000T
DSC1001BL5-133.3330T
DSC1001BL5-150.0000T
DSC1001BL2-025.0000T
DSC1001BL5-050.0000T
DSC1001BL5-016.0000T
DSC1001BL5-080.0000T
DSC1001BE5-022.5792T
DSC1001BL5-020.0000T
DSC1001BE1-012.0000T
DSC1001BL1-016.0000T
DSC1001BE5-064.0000T
DSC1001BL5-064.0000T
DSC1001BL2-020.0000T
DSC1001BL1-060.0000T
DSC1001BE2-012.2880T
DSC1001BE2-014.7450T
DSC1001BE1-001.8432T
DSC1001BE1-026.0000T
DSC1001BE2-048.0000T
DSC1001BE1-014.3182T
DSC1001BE1-014.7456T
DSC1001BE2-014.7456T
DSC1001BE1-133.0000T
DSC1001BL5-001.1385T
DSC1001BL5-001.1386T
DSC1001BL5-001.1387T
DSC1001BL5-001.1388T
DSC1001BL5-001.1389T
DSC1001BL5-108.0000T
DSC1001BE5-020.0000T
DSC1001BL5-033.3330T
DSC1001BL5-026.7000T
DSC1001BL5-026.6500T
DSC1001BE5-016.0000T
DSC1001BL2-048.0000T
DSC1001BL2-026.0000T
DSC1001BL5-026.0000T

DSC1001BL5-120.0000T
DSC1001BL5-014.7456T
DSC1001BL5-033.0000T
DSC1001BE2-090.0000T
DSC1001BL2-024.0000T
DSC1001BL5-125.0000T
DSC1001BE5-024.0000T
DSC1001BL5-030.0000T
DSC1001BE1-066.6666T
DSC1001BL5-049.5000T
DSC1001BE1-001.4850T
DSC1001BL5-072.0000T
DSC1001BL5-066.0000T
DSC1001BL3-001.0000T
DSC1001BE5-033.3330T
DSC1001BL5-075.0000T
DSC1001BL5-004.0000T
DSC1001BE5-012.0000T
DSC1001BE3-026.0000T
DSC1001BL5-058.9824T
DSC1001BE1-060.0000T
DSC1001BE3-022.1184T
DSC1001BL5-032.0000T
DSC1001BE5-030.6400T
DSC1001BL5-106.2500T
DSC1001BL2-125.0000T
DSC1001BE1-004.0625T
DSC1001BE1-004.0960T
DSC1001BL2-012.0000T
DSC1001BE5-027.0000T
DSC1001BE5-030.0000T
DSC1001BE1-033.3333T
DSC1001BL2-012.5000T
DSC1001BL2-050.0000TVAO
DSC1001DE1-024.0000T
DSC1001DE1-026.0000T
DSC1001DE1-027.0000T
DSC1001DE1-048.0000T
DSC1001DE1-054.0000T
DSC1001DE1-100.0000T
DSC1001DE1-125.0000T
DSC1001DE2-020.0000T
DSC1001DE2-024.0000T
DSC1001DE2-050.0000T
DSC1001DL1-008.0000T
DSC1001DE5-019.2000T
DSC1001DL1-025.0000T
DSC1001DL1-027.0000T
DSC1001DL2-012.0000T

DSC1001DL2-008.0000T
DSC1001DL2-020.0000T
DSC1001DL2-025.0000T
DSC1001DL2-024.0000T
DSC1001DL2-027.0000T
DSC1001DL2-030.0000T
DSC1001DL2-032.0000T
DSC1001DL2-050.0000T
DSC1001DL5-001.8432T
DSC1001DL5-002.0000T
DSC1001DL5-007.3728T
DSC1001DL5-008.0000T
DSC1001DL5-010.0000T
DSC1001DL5-011.0592T
DSC1001DL5-016.0000T
DSC1001DL5-019.2000T
DSC1001DL5-020.0000T
DSC1001DL5-024.0000T
DSC1001DL5-024.5760T
DSC1001DL5-025.0000T
DSC1001DL5-026.0000T
DSC1001DL5-027.0000T
DSC1001DL5-030.0000T
DSC1001DL5-031.2500T
DSC1001DL5-033.0000T
DSC1001DL5-033.3330T
DSC1001DL5-048.0000T
DSC1001DL5-050.0000T
DSC1001DL5-048.0000D
DSC1001DL5-075.0000T
DSC1001DL5-080.0000T
DSC1001DL5-100.0000B
DSC1001DL5-100.0000T
DSC1001DL5-125.0000T
DSC1001DE1-012.0000T
DSC1001DL5-015.3600T
DSC1001DL5-010.2000T
DSC1001DL2-037.1250T
DSC1001DE1-040.0000T
DSC1001DE1-050.0000T
DSC1001DL2-150.0000T
DSC1001DL2-090.0000T
DSC1001DL5-012.0000T
DSC1001DL5-004.0000T
DSC1001DE1-025.0000T
DSC1001DL5-133.3330T
DSC1001DL1-010.0000T
DSC1001DL2-072.0000T
DSC1001DL2-087.0655T

DSC1001DL2-049.5000T
DSC1001DL5-060.0000T
DSC1001DL1-037.1250
DSC1001DL1-080.0000T
DSC1001DL2-074.2500T
DSC1001DL5-014.7456T
DSC1001DL1-024.0000T
DSC1001DL2-040.0000T
DSC1001DL1-001.8432T
DSC1001DL2-001.8432T
DSC1001DL2-033.3333T
DSC1001DL1-033.3333T
DSC1001DE1-075.0000T
DSC1001DE2-100.0000T
DSC1001DL2-016.0000T
DSC1001DL1-025.2000T
DSC1001DE1-033.3333T
DSC1001DL5-040.0000T
DSC1001DE1-019.2000T
DSC1001DL2-007.3728T
DSC1001DL5-072.0000T
DSC1001DL5-012.2880T
DSC1001DE2-038.4000T
DSC1001DE1-013.0000T
DSC1001DL2-012.2880T
DSC1001DL2-125.0000T
DSC1001DL2-004.0000T
DSC1001DL1-016.0000T
DSC1001DL2-023.0000T
DSC1001DE1-020.0000T
DSC1001DL2-026.6500T
DSC1001DL5-014.3181T
DSC1001DE2-008.0000T
DSC1001DE2-012.0000T
DSC1001DE2-027.0000T
DSC1001DE2-025.0000T
DSC1001DL5-016.7722T
DSC1001DL2-048.0000T
DSC1001DL2-066.6700T
DSC1001DE1-024.3050T
DSC1001DL2-002.0000T
DSC1001DL1-004.0960T
DSC1001DL2-049.1520T
DSC1001DL2-045.1584T
DSC1001DE5-037.4000T
DSC1001DL5-096.0000T
DSC1001DL2-066.0000T
DSC1001DE5-012.0000T
DSC1001DL2-026.0000T

DSC1001DL2-019.2000T
DSC1001DL1-012.5000T
DSC1001DL2-054.0000T
DSC1001DL3-027.0000T
DSC1001DL3-024.0000T
DSC1001DL5-016.3840T
DSC1001DL2-016.3690T
DSC1001DL2-061.2500T
DSC1001DL5-018.4320T
DSC1001DL5-033.3333T
DSC1001DL2-003.6864T
DSC1001DL5-003.6864T
DSC1001DE2-001.0000T
DSC1001DE2-090.0000T
DSC1001DE2-022.0000T
DSC1001DL5-037.1250T
DSC1001DL5-150.0000T
DSC1001DL2-033.3300T
DSC1001DE5-025.0000T
DSC1001DE1-024.5760T
DSC1001DL5-047.0016T
DSC1001DL1-005.0196T
DSC1001DL2-005.0196T
DSC1001DL5-005.0196T
DSC1001DE3-080.0000T
DSC1001DL1-150.0000T
DSC1001DE3-008.0000T
DSC1001DE5-150.0000T
DSC1001DL1-050.0000T
DSC1001DE5-049.1520T
DSC1001DE5-045.1584T
DSC1001DL1-040.0000T
DSC1001DL5-064.0000T
DSC1001DL5-028.6363T
DSC1001DL5-006.0000T
DSC1001DL1-033.3330T
DSC1001DL5-029.4912T
DSC1001DL1-004.0000T
DSC1001DL2-100.0000T
DSC1001DL5-032.4000T
DSC1001DL5-049.5000T
DSC1001DL2-012.5000T
DSC1001DE2-120.0000T
DSC1001DL1-033.3300T
DSC1001DL5-006.4000T
DSC1001DL1-037.1250T
DSC1001DL5-026.5980T
DSC1001DL5-120.0000T
DSC1001DL5-087.0655T

DSC1001DL1-027.0000TV05
DSC1001DL1-024.0000TV07
DSC1001AE1-050.0000T
DSC1001AE1-016.6667T
DSC1001AE1-025.0000T
DSC1001AE1-033.3333T
DSC1001AE1-048.0000T
DSC1001AE1-125.0000T
DSC1001AE2-125.0000T
DSC1001AE5-098.3040T
DSC1001AL5-007.3728T
DSC1001AL5-001.8432T
DSC1001AL5-004.0000T
DSC1001AL5-008.0000T
DSC1001AL5-012.0000T
DSC1001AL5-016.0000T
DSC1001AL5-016.3840T
DSC1001AL5-018.4320T
DSC1001AL5-080.0000T
DSC1001AL5-100.0000T
DSC1001AL5-032.0000T
DSC1001AL5-040.0000T
DSC1001AL5-050.0000T
DSC1001AL5-060.0000T
DSC1001AL5-125.0000T
DSC1001AE1-066.6660T
DSC1001AE1-019.6608T
DSC1001AE1-024.0000T
DSC1001AE2-002.0480T
DSC1001AL5-024.0000T
DSC1001AE5-024.5760T
DSC1001AE1-027.0000T
DSC1001AL5-033.0000T
DSC1001AL5-025.0000T
DSC1001AE1-006.1440T
DSC1001AE1-111.0000T
DSC1001AL5-027.0000T
DSC1001AE1-014.3182T
DSC1001AE1-024.5761T
DSC1001AE1-003.6864T
DSC1001AE1-054.0000T
DSC1001AE5-040.0000T
DSC1001AL5-066.0000T
DSC1001AE1-018.1059T
DSC1001AL5-030.0000T
DSC1001AE1-049.1520T
DSC1001AL1-001.0000T
DSC1001AL1-048.0000T
DSC1001AL5-016.7772T

DSC1001AE2-148.5000T
DSC1001AE2-048.0000T
DSC1001AE5-022.5792T
DSC1001AE1-001.4850T
DSC1001AL2-016.0000T
DSC1001AE2-080.0000T
DSC1001AL1-020.0000T
DSC1001AE1-004.0000T
DSC1001AE1-099.0000T
DSC1001AE1-098.0000T
DSC1001AL2-025.0000T
DSC1001AE5-004.0000T
DSC1001AE5-020.0000T
DSC1001AE5-125.0000T
DSC1001AE5-012.0000T
DSC1001AE1-010.0000T
DSC1001AL5-001.0000T
DSC1001AE2-050.0000T
DSC1001AE2-054.0000T
DSC1001AE5-029.1621T
DSC1001AE5-031.6440T
DSC1001AL5-011.0592T
DSC1001AL1-050.0000T
DSC1001AL5-010.0000T
DSC1001AL5-133.3330T
DSC1001AL2-020.0000T
DSC1001AL2-060.0000T
DSC1001AE3-013.5600T
DSC1001AE1-064.0000T
DSC1001AE1-040.0000T
DSC1001AL5-014.7456T
DSC1001AE5-017.1776T
DSC1001AE5-001.2000T
DSC1001AL2-029.4912T
DSC1001AL2-050.0000T
DSC1001AE1-003.5700T
DSC1001AL5-033.3330T
DSC1001AL2-024.0000T
DSC1001AL2-125.0000T
DSC1001AL1-025.0000T
DSC1001AL1-027.0000T
DSC1001AL2-100.0000T
DSC1001AL5-029.4912T
DSC1001CI1-132.0000T
DSC1001DC1-025.0000T
DSC1001DC1-050.0000T
DSC1001DC1-072.0000T
DSC1001DC1-074.2500T
DSC1001DC5-038.8800T

DSC1001DC5-037.4000T
DSC1001DC5-012.8000T
DSC1001DC1-100.0000T
DSC1001CI1-001.8432T
DSC1001CI1-007.5000T
DSC1001CI1-008.0000T
DSC1001CI1-010.0000T
DSC1001CI1-001.0000T
DSC1001CI1-013.5600T
DSC1001CI1-014.7456T
DSC1001CI1-016.0000T
DSC1001CI1-019.2000T
DSC1001CI1-020.0000T
DSC1001CI1-024.0000T
DSC1001CI1-024.5760T
DSC1001CI1-025.0000T
DSC1001CI1-026.0000T
DSC1001CI1-027.0000T
DSC1001CI1-030.0000T
DSC1001CI2-004.0000T
DSC1001CI2-008.0000T
DSC1001CI1-033.3333T
DSC1001CI1-047.3333T
DSC1001CI2-018.4320T
DSC1001CI1-050.0000T
DSC1001CI1-076.0686T
DSC1001CI2-014.3181T
DSC1001CI2-001.0000T
DSC1001CI2-002.0480T
DSC1001CI2-003.5795T
DSC1001CI2-022.5792T
DSC1001CI2-006.1400T
DSC1001CI2-011.0592T
DSC1001CI2-012.0000T
DSC1001CI2-012.2880T
DSC1001CI2-014.7456T
DSC1001CI2-016.0000T
DSC1001CI2-024.0000T
DSC1001CI2-024.5760T
DSC1001CI2-025.0000T
DSC1001CI2-026.0000T
DSC1001CI2-027.0000T
DSC1001CI2-027.6000T
DSC1001CI2-028.6363T
DSC1001CI2-080.0000T
DSC1001CI2-032.7680T
DSC1001CI2-033.0000T
DSC1001CI2-033.3300T
DSC1001CI2-033.3333T

DSC1001CI2-034.3000T
DSC1001CI2-036.0000T
DSC1001CI5-032.7680T
DSC1001CI2-037.1250T
DSC1001CI2-040.0000T
DSC1001CI2-048.0000T
DSC1001CI2-050.0000T
DSC1001CI2-054.0000T
DSC1001CI2-060.0000T
DSC1001CI2-066.6660T
DSC1001CI2-066.6666T
DSC1001CI2-074.2500T
DSC1001CI2-100.0000T
DSC1001CI2-125.0000T
DSC1001CI4-002.0480T
DSC1001CI4-049.1520T
DSC1001CI4-054.0000T
DSC1001CI5-004.0000T
DSC1001CI5-004.9152T
DSC1001CI5-008.0000T
DSC1001CI5-010.0000T
DSC1001CI5-012.0000T
DSC1001CI5-012.2880T
DSC1001CI5-016.0000T
DSC1001CI5-018.4320T
DSC1001CI5-019.2000T
DSC1001CI5-020.0000T
DSC1001CI5-024.0000T
DSC1001CI5-024.5760T
DSC1001CI5-025.0000T
DSC1001CI5-026.0000T
DSC1001CI5-027.0000T
DSC1001CI5-030.0000T
DSC1001CI1-003.6864T
DSC1001CI2-012.5000T
DSC1001CI5-009.6000T
DSC1001CI1-100.0000T
DSC1001CI2-020.0000T
DSC1001CI2-006.0000T
DSC1001CI5-040.0000T
DSC1001CI5-044.0000T
DSC1001CI5-019.0000T
DSC1001CI5-060.0000T
DSC1001CI1-033.0000T
DSC1001CI1-048.0000T
DSC1001CI5-011.0592T
DSC1001CI2-031.2500T
DSC1001CI2-049.1520T
DSC1001CI2-032.0000T

DSC1001CI2-096.0000T
DSC1001CI2-100.0000B
DSC1001CI5-133.3330T
DSC1001CI5-070.4550T
DSC1001CI2-008.1920T
DSC1001CI2-010.4857T
DSC1001CI1-011.0592T
DSC1001CI2-001.9521T
DSC1001CI2-019.4400T
DSC1001CI2-026.000T
DSC1001CI2-133.0000T
DSC1001CI5-016.3840T
DSC1001CI5-033.3333T
DSC1001CI5-032.0000T
DSC1001CI5-033.0000T
DSC1001CI5-033.3330T
DSC1001CI2-030.0000T
DSC1001CI5-048.0000T
DSC1001CI5-050.0000T
DSC1001CI5-064.0000T
DSC1001CI5-100.0000T
DSC1001CI5-125.0000T
DSC1001CI5-150.0000T
DSC1001CI5-080.0000T
DSC1001CI1-060.0000T
DSC1001CI2-007.3728T
DSC1001CI2-044.2360T
DSC1001CI1-033.3330T
DSC1001CI2-066.6666B
DSC1001CI2-072.0000T
DSC1001CI2-028.3220T
DSC1001CI2-108.0000T
DSC1001CI2-043.0000T
DSC1001CI1-012.0000T
DSC1001CI2-019.2000T
DSC1001CI2-038.4000T
DSC1001CI2-052.0000T
DSC1001CI2-025.0000B
DSC1001CI2-001.9512T
DSC1001CI2-033.3330T
DSC1001CI5-024.3050T
DSC1001CI5-033.3300T
DSC1001CI5-014.3181T
DSC1001CI5-026.8000T
DSC1001CI2-026.8000T
DSC1001CI2-010.4858T
DSC1001CI1-031.9488T
DSC1001CI1-004.0000T
DSC1001CI5-014.7456T

DSC1001CI5-008.1920T
DSC1001CI2-003.0720T
DSC1001CI1-080.0000T
DSC1001CI5-022.0000T
DSC1001CI2-100.8000T
DSC1001CI5-022.5792T
DSC1001CI2-024.3050T
DSC1001CI1-004.0960T
DSC1001CI5-003.2768T
DSC1001CI5-007.3728T
DSC1001CI2-003.2768T
DSC1001CI3-024.0000T
DSC1001CI3-025.0000T
DSC1001CI3-027.0000T
DSC1001CI3-013.8240T
DSC1001CI5-015.0000T
DSC1001CI5-144.0000T
DSC1001CI5-029.4912T
DSC1001CI2-133.3330T
DSC1001CI3-100.0000T
DSC1001CI2-074.1750T
DSC1001CI5-003.6864T
DSC1001CI3-003.5790T
DSC1001CI1-018.4320T
DSC1001CI1-040.0000T
DSC1001CI2-066.0000T
DSC1001CI2-026.6363T
DSC1001CI1-064.0000T
DSC1001CI2-003.8000T
DSC1001CI3-012.0000T
DSC1001CI3-033.0000T
DSC1001CI1-005.0000T
DSC1001CI3-019.2000T
DSC1001CI3-050.0000T
DSC1001CI1-004.9152T
DSC1001CI2-034.0000T
DSC1001CI5-037.4000T
DSC1001CI2-004.0960T
DSC1001CI5-037.0879T
DSC1001CI2-013.0000T
DSC1001CI1-028.6363T
DSC1001CI3-013.5000T
DSC1001CI1-008.1920T
DSC1001CI2-038.0000T
DSC1001CI3-004.0000T
DSC1001CI5-013.5000T
DSC1001CI2-020.7500T
DSC1001CI5-013.3300T
DSC1001CI2-088.0000T

DSC1001CI2-020.0036T
DSC1001CI2-020.0037T
DSC1001CI1-014.3181T
DSC1001CI1-032.0000T
DSC1001CI5-099.9990T
DSC1001CI2-024.9600T
DSC1001CI2-029.5000T
DSC1001CI1-125.0000T
DSC1001CI1-003.5800T
DSC1001CI5-026.6000T
DSC1001CI1-001.5000T
DSC1001CI1-012.8000T
DSC1001BI1-008.0000T
DSC1001BI1-010.0000T
DSC1001BI1-032.0000T
DSC1001BI1-022.1184T
DSC1001BI1-024.0000T
DSC1001BI1-024.5760T
DSC1001BI1-025.0000T
DSC1001BI1-027.0000T
DSC1001BI1-030.0000T
DSC1001BI1-040.0000T
DSC1001BI1-048.0000T
DSC1001BI1-050.0000T
DSC1001BI1-060.0000T
DSC1001BI1-125.0000T
DSC1001BI2-001.8432T
DSC1001BI2-002.0480T
DSC1001BI2-005.5296T
DSC1001BI2-006.0000T
DSC1001BI2-008.0000T
DSC1001BI2-012.0000T
DSC1001BI2-012.2880T
DSC1001BI2-014.7456T
DSC1001BI2-016.0000T
DSC1001BI2-016.3840T
DSC1001BI2-020.0000T
DSC1001BI2-020.0016T
DSC1001BI2-022.5790T
DSC1001BI2-024.0000T
DSC1001BI2-024.5760T
DSC1001BI2-025.0000T
DSC1001BI2-007.3728T
DSC1001BI2-027.0000T
DSC1001BI2-028.8000T
DSC1001BI2-032.0000T
DSC1001BI2-033.3330T
DSC1001BI2-040.0000T
DSC1001BI2-042.5000T

DSC1001BI2-044.0000T
DSC1001BI2-048.0000T
DSC1001BI2-049.0908T
DSC1001BI2-050.0000T
DSC1001BI2-059.0000T
DSC1001BI2-062.5000T
DSC1001BI2-080.0000T
DSC1001BI2-100.0000T
DSC1001BI2-106.2500T
DSC1001BI2-125.0000T
DSC1001BI2-133.0000T
DSC1001BI2-148.5000T
DSC1001BI5-003.6864T
DSC1001BI5-004.0000T
DSC1001BI5-007.3728T
DSC1001BI5-008.0000T
DSC1001BI5-010.0000T
DSC1001BI5-012.0000T
DSC1001BI5-016.0000T
DSC1001BI5-024.0000T
DSC1001BI5-025.0000T
DSC1001BI5-032.0000T
DSC1001BI5-033.3330T
DSC1001BI5-040.0000T
DSC1001BI5-048.0000T
DSC1001BI5-050.0000T
DSC1001BI5-066.0000T
DSC1001BI5-066.6666T
DSC1001BI5-072.0000T
DSC1001BI5-100.0000T
DSC1001BI5-120.0000T
DSC1001BI5-125.0000T
DSC1001BI5-030.0000T
DSC1001BI1-038.4000T
DSC1001BI2-018.4320T
DSC1001BI5-020.0000T
DSC1001BI5-133.3330T
DSC1001BI1-004.0000T
DSC1001BI2-030.0000T
DSC1001BI1-012.2880T
DSC1001BI2-014.3181T
DSC1001BI1-020.0000T
DSC1001BI5-090.0000T
DSC1001BI1-066.6666T
DSC1001BI2-133.3330T
DSC1001BI1-016.0000T
DSC1001BI2-012.5000T
DSC1001BI5-013.5600T
DSC1001BI1-100.0000T

DSC1001BI1-012.0000T
DSC1001BI2-033.0000T
DSC1001BI2-026.0000T
DSC1001BI5-084.0000T
DSC1001BI1-033.3330T
DSC1001BI2-012.2888T
DSC1001BI2-004.0000T
DSC1001BI2-010.0000T
DSC1001BI2-013.0810T
DSC1001BI2-054.0000T
DSC1001BI5-014.7456T
DSC1001BI2-028.6363T
DSC1001BI5-033.0000T
DSC1001BI2-016.9344T
DSC1001BI5-027.0000T
DSC1001BI1-080.0000T
DSC1001BI1-019.6608T
DSC1001BI5-028.6363T
DSC1001BI5-001.6000T
DSC1001BI1-001.8432T
DSC1001BI5-125.0031T
DSC1001BI1-011.0592T
DSC1001BI5-080.0000T
DSC1001BI1-026.0000T
DSC1001BI3-024.0000T
DSC1001BI3-012.0000T
DSC1001BI5-018.4320T
DSC1001BI2-029.4912T
DSC1001BI3-033.0000T
DSC1001BI3-050.0000T
DSC1001BI2-001.5440T
DSC1001BI1-033.0000T
DSC1001BI1-133.0000T
DSC1001BI2-011.0592T
DSC1001BI5-019.6800T
DSC1001BI1-003.6864T
DSC1001BI2-003.1250T
DSC1001BI5-066.6660T
DSC1001BI1-099.0000T
DSC1001BI2-099.0000T
DSC1001BI5-040.9600T
DSC1001BI2-003.6864T
DSC1001BI3-020.0000T
DSC1001BI2-040.6800T
DSC1001BI2-033.3300T
DSC1001DI1-001.8432T
DSC1001DI1-003.6864T
DSC1001DI1-004.0000T
DSC1001DI1-005.0000T

DSC1001DI1-005.0196T
DSC1001DI1-008.0000T
DSC1001DI1-010.0000T
DSC1001DI1-012.0000T
DSC1001DI1-014.7456T
DSC1001DI1-016.0000T
DSC1001DI1-016.3840T
DSC1001DI1-019.2000T
DSC1001DI1-020.0000T
DSC1001DI1-024.0000T
DSC1001DI1-024.5760T
DSC1001DI1-025.0000T
DSC1001DI1-026.0000T
DSC1001DI1-027.0000T
DSC1001DI1-033.3000T
DSC1001DI1-133.0000T
DSC1001DI1-033.3330T
DSC1001DI1-033.3333T
DSC1001DI1-048.0000T
DSC1001DI1-125.0000T
DSC1001DI1-050.0000T
DSC1001DI1-033.3300T
DSC1001DI1-098.3040T
DSC1001DI2-009.6000T
DSC1001DI2-001.0000T
DSC1001DI2-003.6864T
DSC1001DI2-004.0960T
DSC1001DI2-005.0196T
DSC1001DI2-008.0000T
DSC1001DI2-010.0000T
DSC1001DI2-012.0000T
DSC1001DI2-012.2880T
DSC1001DI2-016.0000T
DSC1001DL5-001.0000T
DSC1001DI2-033.3300T
DSC1001DI2-019.2000T
DSC1001DI2-020.0000T
DSC1001DI2-022.0000T
DSC1001DI2-022.5792T
DSC1001DI2-024.0000T
DSC1001DI2-024.5455T
DSC1001DI2-024.5760B
DSC1001DI2-024.5760T
DSC1001DI2-025.0000T
DSC1001DI2-026.0000T
DSC1001DI2-027.0000T
DSC1001DI2-028.3220T
DSC1001DI2-029.5000T
DSC1001DI2-032.0000T

DSC1001DI2-066.6600T
DSC1001DI2-033.3333T
DSC1001DI2-036.8182T
DSC1001DI2-037.1250T
DSC1001DI5-002.4576T
DSC1001DI2-038.4000T
DSC1001DI2-040.0000T
DSC1001DI2-048.0000T
DSC1001DI2-049.0909T
DSC1001DI2-050.0000T
DSC1001DI2-072.0000T
DSC1001DI2-074.1758T
DSC1001DI2-074.2500T
DSC1001DI2-080.0000T
DSC1001DI2-100.0000T
DSC1001DI2-125.0000T
DSC1001DI2-128.0000T
DSC1001DI4-010.0000T
DSC1001DI4-010.0503T
DSC1001DI4-010.0587T
DSC1001DI4-059.7800T
DSC1001DI4-060.0700T
DSC1001DI4-066.4860T
DSC1001DI4-066.5800T
DSC1001DI5-002.0480T
DSC1001DI2-047.3885T
DSC1001DI1-038.4000T
DSC1001DI2-026.6000T
DSC1001DI1-066.0000T
DSC1001DI5-008.0000T
DSC1001DI5-047.3885T
DSC1001DI5-013.3333T
DSC1001DI5-022.5792T
DSC1001DI5-030.0000T
DSC1001DI2-024.5454T
DSC1001DI5-033.0000T
DSC1001DI1-100.0000T
DSC1001DI1-033.0000T
DSC1001DI1-072.0000T
DSC1001DI1-030.0000T
DSC1001DI1-050.0000B
DSC1001DI5-150.0000T
DSC1001DI1-032.0000T
DSC1001DI2-014.7456T
DSC1001DI2-028.6363T
DSC1001DI2-031.2500T
DSC1001DI5-003.6864T
DSC1001DI5-004.0000T
DSC1001DI5-006.0000T

DSC1001DI5-007.3728T
DSC1001DI5-008.0174T
DSC1001DI5-008.1920T
DSC1001DI5-010.0000T
DSC1001DI5-012.0000T
DSC1001DI5-016.0000T
DSC1001DI5-019.2000T
DSC1001DI5-020.0000T
DSC1001DI5-024.0000T
DSC1001DI5-024.5760T
DSC1001DI5-025.0000T
DSC1001DI5-026.0000T
DSC1001DI5-027.0000T
DSC1001DI5-028.6363T
DSC1001DI5-029.4912T
DSC1001DI5-032.0000T
DSC1001DI5-033.3330T
DSC1001DI5-001.8432T
DSC1001DI2-018.0000T
DSC1001DI5-044.0000T
DSC1001DI5-048.0000T
DSC1001DI5-050.0000T
DSC1001DI5-060.0000T
DSC1001DI5-075.0000T
DSC1001DI5-080.0000T
DSC1001DI5-100.0000T
DSC1001DI5-125.0000T
DSC1001DI1-074.2500T
DSC1001DL5-032.0000T
DSC1001DI1-054.0000T
DSC1001DI2-006.7800T
DSC1001DI2-054.0000T
DSC1001DI5-047.3385T
DSC1001DI5-038.4000T
DSC1001DI1-060.0000T
DSC1001DI2-030.0000T
DSC1001DI2-001.8432T
DSC1001DI5-033.3333T
DSC1001DI2-066.0000T
DSC1001DI5-133.3330T
DSC1001DI5-018.4320T
DSC1001DI1-018.4320T
DSC1001DI2-004.0000T
DSC1001DI1-004.9152T
DSC1001DI2-045.1584T
DSC1001DI2-049.1520T
DSC1001DI2-011.0592T
DSC1001DI2-032.7680T
DSC1001DI1-016.6666T

DSC1001DI5-087.0655T
DSC1001DI1-045.1584T
DSC1001DI5-025.6000T
DSC1001DI1-045.5840T
DSC1001DI1-013.3300T
DSC1001DI2-003.0720T
DSC1001DI2-057.2727T
DSC1001DI2-096.0000T
DSC1001DI2-023.0000T
DSC1001DI5-054.0000T
DSC1001DI1-029.4912T
DSC1001DI5-013.5288T
DSC1001DI1-007.3728T
DSC1001DI1-080.0000T
DSC1001DI1-002.0000T
DSC1001DI2-064.0000T
DSC1001DI3-024.0000T
DSC1001DI5-032.7680T
DSC1001DI1-011.0592T
DSC1001DI3-012.0000T
DSC1001DI2-033.0000T
DSC1001DI5-011.0592T
DSC1001DI2-133.0000T
DSC1001DI2-002.0970T
DSC1001DI3-100.0000T
DSC1001DI3-133.0000T
DSC1001DI1-064.0000T
DSC1001DI5-019.6800T
DSC1001DI1-025.0008T
DSC1001DI5-090.0000T
DSC1001DI5-014.3181T
DSC1001DI1-116.6666T
DSC1001DI2-066.6670T
DSC1001DI5-009.2160T
DSC1001DI2-060.0000T
DSC1001DI5-005.0196T
DSC1001DI5-037.4000T
DSC1001DI1-028.6363T
DSC1001DI3-012.2880T
DSC1001DI3-040.0000T
DSC1001DI2-070.0000T
DSC1001DI3-060.0000T
DSC1001DI5-057.5580T
DSC1001DI1-036.0000T
DSC1001DI1-038.0000T
DSC1001DI5-030.7200T
DSC1001DI3-027.0000T
DSC1001DI2-014.3181T
DSC1001DI5-040.0000T

DSC1001DI1-069.1200T
DSC1001DI5-032.4000T
DSC1001DI5-041.1420T
DSC1001DI5-014.7456T
DSC1001DI1-014.7456TV08
DSC1001DI1-020.0000TV09
DSC1001AI1-012.2880T
DSC1001AI2-006.0000T
DSC1001AI1-025.0000T
DSC1001AI2-008.0000T
DSC1001AI2-012.0000T
DSC1001AI2-012.2880T
DSC1001AI2-016.0000T
DSC1001AI2-016.3840T
DSC1001AI2-125.0000T
DSC1001AI2-024.0000T
DSC1001AI2-024.5760T
DSC1001AI2-025.0000T
DSC1001AI2-025.0007T
DSC1001AI2-026.0000T
DSC1001AI2-032.0000T
DSC1001AI2-014.3180T
DSC1001AI2-050.0000T
DSC1001AI2-054.0000T
DSC1001AI5-150.0000T
DSC1001AI2-066.0000T
DSC1001AI2-098.3040T
DSC1001AI2-100.0000T
DSC1001AI2-120.0000T
DSC1001AI2-133.0000T
DSC1001AI5-002.4576T
DSC1001AI5-008.0000T
DSC1001AI5-011.0592T
DSC1001AI5-012.0000T
DSC1001AI5-016.0000T
DSC1001AI3-029.4912T
DSC1001AI5-018.4320T
DSC1001AI5-020.0000T
DSC1001AI5-024.5760T
DSC1001AI5-025.0000T
DSC1001AI5-027.0000T
DSC1001AI5-029.4912T
DSC1001AI5-033.3330T
DSC1001AI5-048.0000T
DSC1001AI5-080.0000T
DSC1001AI5-100.0000T
DSC1001AI5-125.0000T
DSC1001AI5-125.0060T
DSC1001AI2-066.6600T

DSC1001AI1-120.0000T
DSC1001AI2-027.0016T
DSC1001AI2-066.6670T
DSC1001AI1-055.3330T
DSC1001AI5-032.0000T
DSC1001AI2-096.0000T
DSC1001AI5-033.0000T
DSC1001AI2-001.0000T
DSC1001AI2-064.0000T
DSC1001AI2-048.0000T
DSC1001AI1-050.0000T
DSC1001AI2-010.0000T
DSC1001AI2-027.0000T
DSC1001AI2-011.7000T
DSC1001AI2-012.3667T
DSC1001AI5-040.0000T
DSC1001AI5-024.0000T
DSC1001AI1-033.0000T
DSC1001AI2-040.0000T
DSC1001AI1-049.1520T
DSC1001AI5-012.2880T
DSC1001AI1-016.0000T
DSC1001AI1-001.0000T
DSC1001AI5-066.0000T
DSC1001AI1-066.0000T
DSC1001AI1-020.0000T
DSC1001AI1-013.1072T
DSC1001AI1-024.5760T
DSC1001AI1-030.0000T
DSC1001AI5-050.0000T
DSC1001AI1-008.0000T
DSC1001AI1-032.7680T
DSC1001AI2-002.0480T
DSC1001AI1-033.3333T
DSC1001AI2-065.5360T
DSC1001AI2-032.7680T
DSC1001AI1-003.5700T
DSC1001AI5-028.6363T
DSC1001AI2-075.0000T
DSC1001AI2-150.0000T
DSC1001AI1-007.3728T
DSC1001AI1-004.9152T
DSC1001AI1-012.0000T
DSC1001AI2-033.3330T
DSC1001AI5-016.3840T
DSC1001AI5-010.0000T
DSC1001AI5-106.2500T
DSC1001AI1-014.3182T
DSC1001AI3-025.0000T

DSC1001AI3-030.0000T
DSC1001AI1-033.3330T
DSC1001AI1-024.5450T
DSC1001AI5-001.7000T
DSC1001AI5-014.7456T
DSC1001AI2-029.4912T
DSC1001AI3-100.0000T
DSC1001AI1-075.0000T
DSC1001AI2-129.6000T
DSC1001AI3-040.0000T
DSC1001AI2-066.6666T
DSC1001AI1-029.4912T
DSC1001AI5-002.0480T
DSC1001AI1-026.0000T
DSC1001AI1-016.3840T
DSC1001AI1-032.0000T
DSC1001AI5-003.6864T
DSC1001CI2-015.3600
DSC1001CI1-012.8000
DSC1001CI3-048.0000
DSC1001CI3-114.2850
DSC1001CI2-062.5000
DSC1001CI5-075.0000
DSC1001CI3-148.5000
DSC1001CI5-045.1584
DSC1001CI5-049.1520
DSC1001CI1-038.4000
DSC1001CI3-033.3333
DSC1001CI3-125.0063
DSC1001CI5-045.1850
DSC1001CI2-010.0000
DSC1001CI1-029.4912
DSC1001CI5-005.0000
DSC1001CI5-045.1854
DSC1001CI2-009.6000
DSC1001CI1-033.3300
DSC1001CI5-017.1776
DSC1001CI2-029.4912
DSC1001CI2-003.1250
DSC1001CI2-001.8432
DSC1001CI1-090.0000
DSC1001BI3-022.5792
DSC1001BI3-024.5760
DSC1001BI2-048.4610
DSC1001BI5-024.5760
DSC1001BI5-150.0000
DSC1001BI2-027.1200
DSC1001BI2-060.0000
DSC1001BI3-012.7281

DSC1001BI1-002.0480
DSC1001BI2-011.2896
DSC1001BI1-004.8000
DSC1001BI1-007.3728
DSC1001DI2-036.0000
DSC1001DI2-024.0004
DSC1001DI2-033.3330
DSC1001DI1-028.6360
DSC1001DI2-019.6608
DSC1001DI5-038.8800
DSC1001DI2-001.2000
DSC1001DI2-085.0000
DSC1001DI1-044.0000
DSC1001DI1-150.0000
DSC1001DI2-006.1400
DSC1001DI1-040.0000
DSC1001DI3-025.0000
DSC1001DI1-028.6364
DSC1001DI3-020.0032
DSC1001DI5-110.0000
DSC1001DI2-022.1184
DSC1001AI5-060.0000
DSC1001AI3-125.0063
DSC1001AI3-050.0000
DSC1001AI1-003.6864
DSC1001AI1-125.0000
DSC1001AI1-080.0000
DSC1001AI2-003.4000
DSC1001AI1-020.4800
DSC1001AI1-100.0000
DSC1001AI5-133.3330
DSC1001AI5-030.0000
DSC1001CE1-004.8500
DSC1001CE3-032.0000
DSC1001CE3-064.0000
DSC1001CE1-002.0800
DSC1001CE1-016.0000
DSC1001CE1-120.0000
DSC1001CL2-080.0000
DSC1001CE1-003.5000
DSC1001CL2-120.0000
DSC1001CE2-075.0000
DSC1001CE3-024.0000
DSC1001CL2-066.6666
DSC1001CL2-060.0000
DSC1001CL3-006.1440
DSC1001CL1-027.0000
DSC1001CL2-066.0000
DSC1001CL2-133.0000

DSC1001CL1-018.4320
DSC1001CE5-020.9715
DSC1001BE1-033.3330
DSC1001BE1-020.0000
DSC1001BL5-027.0000
DSC1001BL1-040.0000
DSC1001BL2-040.0000
DSC1001BE1-080.0000
DSC1001BL5-049.7000
DSC1001DL3-125.0000
DSC1001DL1-007.3728
DSC1001DL2-011.2896
DSC1001AE1-026.5939
DSC1001AE1-007.5000
DSC1001AE2-075.0000
DSC1001AL5-020.0000
DSC1001CE1-004.8500T
DSC1001CE3-032.0000T
DSC1001CE3-064.0000T
DSC1001CE1-002.0800T
DSC1001CE1-016.0000T
DSC1001CE1-120.0000T
DSC1001CL2-080.0000T
DSC1001CE1-003.5000T
DSC1001CL2-120.0000T
DSC1001CE2-075.0000T
DSC1001CE3-024.0000T
DSC1001CL2-066.6666T
DSC1001CL2-060.0000T
DSC1001CL3-006.1440T
DSC1001CL1-027.0000T
DSC1001CL2-066.0000T
DSC1001CL2-133.0000T
DSC1001CL1-018.4320T
DSC1001CE5-020.9715T
DSC1001BE1-040.0000T
DSC1001BE1-033.3330T
DSC1001BE1-020.0000T
DSC1001BL5-027.0000T
DSC1001BL1-040.0000T
DSC1001BL2-040.0000T
DSC1001BE1-080.0000T
DSC1001BL5-049.7000T
DSC1001DE5-018.4320T
DSC1001DL3-125.0000T
DSC1001DL1-007.3728T
DSC1001DL2-011.2896T
DSC1001AE1-026.5939T
DSC1001AE1-007.5000T

DSC1001AE2-075.0000T
DSC1001AL5-020.0000T
DSC1001CI2-015.3600T
DSC1001CI3-048.0000T
DSC1001CI3-114.2850T
DSC1001CI2-062.5000T
DSC1001CI5-075.0000T
DSC1001CI3-148.5000T
DSC1001CI5-045.1584T
DSC1001CI5-049.1520T
DSC1001CI1-038.4000T
DSC1001CI3-033.3333T
DSC1001CI3-125.0063T
DSC1001CI5-045.1850T
DSC1001CI2-010.0000T
DSC1001CI1-029.4912T
DSC1001CI5-005.0000T
DSC1001CI5-045.1854T
DSC1001CI2-009.6000T
DSC1001CI1-033.3300T
DSC1001CI5-017.1776T
DSC1001CI2-029.4912T
DSC1001CI2-003.1250T
DSC1001CI2-001.8432T
DSC1001CI1-090.0000T
DSC1001BI3-022.5792T
DSC1001BI3-024.5760T
DSC1001BI2-048.4610T
DSC1001BI5-024.5760T
DSC1001BI5-150.0000T
DSC1001BI2-027.1200T
DSC1001BI2-060.0000T
DSC1001BI3-012.7281T
DSC1001BI1-002.0480T
DSC1001BI2-011.2896T
DSC1001BI1-004.8000T
DSC1001BI1-007.3728T
DSC1001DI5-133.0000T
DSC1001DI2-036.0000T
DSC1001DI2-024.0004T
DSC1001DI2-033.3330T
DSC1001DI1-028.6360T
DSC1001DI2-019.6608T
DSC1001DI5-038.8800T
DSC1001DI2-001.2000T
DSC1001DI2-085.0000T
DSC1001DI1-044.0000T
DSC1001DI1-150.0000T
DSC1001DI2-006.1400T

DSC1001DI1-040.0000T
DSC1001DI3-025.0000T
DSC1001DI1-028.6364T
DSC1001DI3-020.0032T
DSC1001DI5-110.0000T
DSC1001DI2-022.1184T
DSC1001AI5-060.0000T
DSC1001AI3-125.0063T
DSC1001AI3-050.0000T
DSC1001AI1-003.6864T
DSC1001AI1-125.0000T
DSC1001AI1-080.0000T
DSC1001AI2-003.4000T
DSC1001AI1-020.4800T
DSC1001AI1-100.0000T
DSC1001AI5-133.3330T
DSC1001AI5-030.0000T
DSC1003CI1-050.0000
DSC1003CI5-020.0000
DSC1003CI5-087.5000
DSC1003CI5-025.0000
DSC1003CI2-100.0000
DSC1003CI2-025.0000
DSC1003CI2-050.0000
DSC1003CI5-099.7200
DSC1003CI2-024.0000
DSC1003CI2-080.0000
DSC1003CI1-070.0000
DSC1003CI2-027.0000
DSC1003CI5-080.0000
DSC1003CI2-010.0000
DSC1003CI5-040.0000
DSC1003CI2-020.0000
DSC1003CI1-025.0000
DSC1003BI2-025.0000
DSC1003BI1-008.0000
DSC1003BI5-001.7000
DSC1003BI5-001.6500
DSC1003BI1-100.0000
DSC1003BI5-040.0000
DSC1003DI2-024.5760
DSC1003DI2-100.0000
DSC1003DI5-024.5760
DSC1003DI2-027.1200
DSC1003DI2-013.5288
DSC1003DI2-024.5670
DSC1003DI5-025.0000
DSC1003DI1-012.0000
DSC1003DI2-050.0000

DSC1003DI1-052.0000
DSC1003DI2-024.0000
DSC1003DI2-033.3333
DSC1003AI2-025.0000
DSC1003AI2-075.0000
DSC1003AI3-100.0000
DSC1003AI5-003.6864
DSC1003AI3-012.0000
DSC1003AI2-125.0000
DSC1003CL2-066.0000
DSC1003CL2-025.0000
DSC1003CL2-027.0000
DSC1003CL5-050.0000
DSC1003CL2-024.0000
DSC1003CL2-050.0000
DSC1003CL1-020.0000
DSC1003BE1-025.0000
DSC1003BL1-010.0000
DSC1003BE1-024.0000
DSC1003BL3-030.0000
DSC1003BL3-008.1920
DSC1003BL3-020.0000
DSC1003BL3-032.7680
DSC1003BL3-013.8420
DSC1003BL3-025.0000
DSC1003BL3-010.2400
DSC1003BL3-018.4320
DSC1003DE1-040.0000
DSC1003DL2-008.0000
DSC1003DL5-020.0000
DSC1003DL5-100.0000
DSC1003DL5-125.0000
DSC1003DL5-148.5000
DSC1003DL1-125.0000
DSC1003DL2-025.0000
DSC1003DL5-025.0000
DSC1003DL2-070.0000
DSC1003DL2-100.0000
DSC1003DE1-024.0000
DSC1003DL2-080.0000
DSC1003DL1-027.0000
DSC1003DL5-019.2000
DSC1003DL1-033.3333
DSC1003DL1-024.5454
DSC1003DL2-033.3333
DSC1003DL1-025.0000
DSC1003DL1-016.0000
DSC1003DL1-050.0000
DSC1003DL1-048.0000

DSC1003DL2-024.0000
DSC1003AE5-100.0000
DSC1003AL5-025.0000
DSC1003AE1-022.1184
DSC1003AE5-025.0000
DSC1003AE3-007.3728
DSC1003AL2-005.0000
DSC1003CL1-048.0000T
DSC1003CL1-095.0000T
DSC1003CL2-025.0000T
DSC1003CL2-027.0000T
DSC1003CL5-050.0000T
DSC1003CL2-024.0000T
DSC1003CL2-050.0000T
DSC1003CL1-020.0000T
DSC1003BE1-025.0000T
DSC1003BL1-010.0000T
DSC1003BE1-024.0000T
DSC1003BL3-030.0000T
DSC1003BL3-008.1920T
DSC1003BL3-020.0000T
DSC1003BL3-032.7680T
DSC1003BL3-013.8420T
DSC1003BL3-025.0000T
DSC1003BL3-010.2400T
DSC1003BL3-018.4320T
DSC1003DL5-100.0000T
DSC1003DL2-008.0000T
DSC1003DL2-050.0000T
DSC1003DL2-090.0000T
DSC1003DL2-148.5000T
DSC1003DL5-020.0000T
DSC1003DL5-125.0000T
DSC1003DL2-070.0000T
DSC1003DL5-148.5000T
DSC1003DL2-100.0000T
DSC1003DE1-050.0000T
DSC1003DL1-125.0000T
DSC1003DL2-025.0000T
DSC1003DL5-025.0000T
DSC1003DL2-080.0000T
DSC1003DL1-027.0000T
DSC1003DL5-019.2000T
DSC1003DL1-033.3333T
DSC1003DL1-024.5454T
DSC1003DL2-033.3333T
DSC1003DL1-025.0000T
DSC1003DL1-016.0000T
DSC1003DL1-050.0000T

DSC1003DL1-048.0000T
DSC1003DL2-024.0000T
DSC1003AE1-050.0000T
DSC1003AE5-100.0000T
DSC1003AL5-025.0000T
DSC1003AE1-022.1184T
DSC1003AE5-025.0000T
DSC1003AE3-007.3728T
DSC1003AL2-005.0000T
DSC1003CI5-020.0000T
DSC1003CI1-050.0000T
DSC1003CI5-025.0000T
DSC1003CI2-025.0000T
DSC1003CI2-050.0000T
DSC1003CI5-099.7200T
DSC1003CI2-024.0000T
DSC1003CI2-080.0000T
DSC1003CI1-070.0000T
DSC1003CI2-027.0000T
DSC1003CI5-080.0000T
DSC1003CI2-010.0000T
DSC1003CI5-040.0000T
DSC1003CI2-020.0000T
DSC1003CI1-025.0000T
DSC1003BI1-060.0000T
DSC1003BI2-025.0000T
DSC1003BI1-008.0000T
DSC1003BI5-001.7000T
DSC1003BI5-001.6500T
DSC1003BI1-100.0000T
DSC1003BI5-040.0000T
DSC1003DI2-024.5760T
DSC1003DI2-100.0000T
DSC1003DI2-027.1200T
DSC1003DI2-013.5288T
DSC1003DI2-024.5670T
DSC1003DI5-025.0000T
DSC1003DI1-012.0000T
DSC1003DI2-050.0000T
DSC1003DI1-052.0000T
DSC1003DI2-024.0000T
DSC1003DI2-033.3333T
DSC1003AI2-050.0000T
DSC1003AI2-075.0000T
DSC1003AI3-100.0000T
DSC1003AI5-003.6864T
DSC1003AI3-012.0000T
DSC1003AI2-125.0000T
DSC1003CI2-008.0000

DSC1003CI3-125.0063
DSC1003CI2-033.0000
DSC1003CI2-040.0000
DSC1003BI1-050.0000
DSC1003BI2-050.0000
DSC1003DI5-050.0000
DSC1003DI2-025.0000
DSC1003AI5-125.0000
DSC1003AI3-125.0063
DSC1003AI1-081.3600
DSC1003CL3-133.3330
DSC1003DL3-020.0000
DSC1003DL3-025.0000
DSC1003CL2-066.0000T
DSC1003CL3-133.3330T
DSC1003DL3-020.0000T
DSC1003DL3-025.0000T
DSC1003CI2-008.0000T
DSC1003CI3-125.0063T
DSC1003CI2-033.0000T
DSC1003CI2-040.0000T
DSC1003BI1-050.0000T
DSC1003BI2-050.0000T
DSC1003DI5-050.0000T
DSC1003DI2-025.0000T
DSC1003AI5-125.0000T
DSC1003AI3-125.0063T
DSC1003AI1-081.3600T
DSC1004DC1-020.0000
DSC1004CI5-081.0000
DSC1004CI2-027.0000
DSC1004CI5-050.0000
DSC1004CI5-016.0000
DSC1004CI2-098.3040
DSC1004CI2-024.5760
DSC1004CI5-121.5000
DSC1004CI2-060.0000
DSC1004CI1-016.0000
DSC1004CI5-100.0000
DSC1004CI5-025.0000
DSC1004CI5-026.6000
DSC1004BI2-033.0000
DSC1004BI2-100.0000
DSC1004BI2-010.0000
DSC1004BI5-016.0000
DSC1004BI5-121.5000
DSC1004BI5-005.0000
DSC1004DI1-024.0000
DSC1004DI2-025.0000

DSC1004DI2-012.0000
DSC1004DI2-010.0000
DSC1004DI2-016.0000
DSC1004DI2-100.0000
DSC1004DI2-048.0000
DSC1004DI2-060.0000
DSC1004DI2-072.0000
DSC1004DI2-086.4000
DSC1004DI5-025.0000
DSC1004DI5-066.4860
DSC1004DI5-066.5800
DSC1004DI1-006.7800
DSC1004DI2-133.0000
DSC1004DI1-050.0000
DSC1004DI2-050.0000
DSC1004DI5-024.0000
DSC1004DI5-016.0000
DSC1004DI1-026.0000
DSC1004DI2-076.0000
DSC1004AI2-001.0000
DSC1004AI5-099.7200
DSC1004AI1-012.0000
DSC1004AI1-004.9152
DSC1004AI1-007.3728
DSC1004CE1-050.0000
DSC1004CE2-072.0000
DSC1004CE1-033.3333
DSC1004CL5-016.0000
DSC1004CL2-027.0000
DSC1004CE1-025.6000
DSC1004CL2-003.2768
DSC1004CL2-030.0000
DSC1004BL2-025.0000
DSC1004BL2-024.0000
DSC1004DL5-040.0000
DSC1004DL1-027.0000
DSC1004DL1-025.0000
DSC1004DL1-033.0000
DSC1004DL2-072.0000
DSC1004DL5-025.0000
DSC1004DE1-026.0000
DSC1004DE2-025.0000
DSC1004DL2-025.0000
DSC1004AL2-001.0000
DSC1004AL1-001.0000
DSC1004AE2-024.0000
DSC1004CE1-033.3333T
DSC1004CL5-016.0000T
DSC1004CL2-027.0000T

DSC1004CE1-025.6000T
DSC1004CL2-003.2768T
DSC1004CL2-030.0000T
DSC1004BL2-025.0000T
DSC1004BL2-024.0000T
DSC1004DL5-040.0000T
DSC1004DL1-027.0000T
DSC1004DL1-025.0000T
DSC1004DL1-033.0000T
DSC1004DL2-072.0000T
DSC1004DL5-025.0000T
DSC1004DE1-026.0000T
DSC1004DE2-025.0000T
DSC1004DL2-025.0000T
DSC1004AL1-001.0000T
DSC1004AL2-001.0000T
DSC1004AE2-024.0000T
DSC1004DC1-050.0000T
DSC1004DC1-020.0000T
DSC1004CI2-027.0000T
DSC1004CI2-033.0000T
DSC1004CI2-054.0000T
DSC1004CI5-050.0000T
DSC1004CI5-125.0000T
DSC1004CI5-016.0000T
DSC1004CI2-098.3040T
DSC1004CI2-024.5760T
DSC1004CI5-121.5000T
DSC1004CI2-060.0000T
DSC1004CI1-016.0000T
DSC1004CI5-100.0000T
DSC1004CI5-025.0000T
DSC1004CI5-026.6000T
DSC1004BI2-010.0000T
DSC1004BI5-016.0000T
DSC1004BI5-121.5000T
DSC1004BI5-005.0000T
DSC1004DI2-025.0000T
DSC1004DI2-012.0000T
DSC1004DI2-010.0000T
DSC1004DI2-016.0000T
DSC1004DI1-024.0000T
DSC1004DI2-072.0000T
DSC1004DI5-010.0000T
DSC1004DI5-066.4860T
DSC1004DI5-066.5800T
DSC1004DI1-006.7800T
DSC1004DI2-133.0000T
DSC1004DI1-050.0000T

DSC1004DI2-050.0000T
DSC1004DI5-024.0000T
DSC1004DI5-016.0000T
DSC1004DI1-026.0000T
DSC1004DI2-076.0000T
DSC1004AI2-040.0000T
DSC1004AI2-001.0000T
DSC1004AI5-099.7200T
DSC1004AI1-012.0000T
DSC1004AI1-004.9152T
DSC1004AI1-007.3728T
DSC1004CI1-063.2200
DSC1004BI2-025.0000
DSC1004AI1-081.3600
DSC1004AI1-090.0000
DSC1004CE5-020.9715
DSC1004CE5-020.9715T
DSC1004CI1-063.2200T
DSC1004BI2-025.0000T
DSC1004AI1-081.3600T
DSC1004AI1-090.0000T

1.8V-3.3V Low-Power Precision CMOS Oscillators

Features

- Frequency Range: 1 MHz to 150 MHz
- Exceptional Stability over Temperature
 - ± 10 ppm, ± 20 ppm, ± 25 ppm, ± 50 ppm
- Operating Voltage
 - 1.7 to 3.6V
- Operating Temperature Range
 - Ext. Industrial -40°C to 105°C
 - Industrial -40°C to 85°C
 - Commercial -20°C to 70°C
- Low Operating and Standby Current
 - 6 mA Operating (1 MHz)
 - 15 μA Standby (Max.)
- Ultra Miniature Footprint
 - 2.5 mm x 2.0 mm x 0.85 mm
 - 3.2 mm x 2.5 mm x 0.85 mm
 - 5.0 mm x 3.2 mm x 0.85 mm
 - 7.0 mm x 5.0 mm x 0.85 mm
- MIL-STD 883 Shock and Vibration Resistant
- Pb Free, RoHS, Reach SVHC Compliant
- AEC-Q100 Reliability Qualified

Applications

- Mobile Applications
- Consumer Electronics
- Portable Electronics
- DVR, CCTV, Surveillance Cameras
- Low Profile Applications
- Industrial Applications

Benefits

- Pin for Pin “Drop-In” Replacement for Industry Standard Oscillators
- Semiconductor Level Reliability, Significantly Higher than Quartz
- Short Mass Production Lead Times
- Longer Battery Life/Reduced Power Consumption
- Compact Plastic Package
- Cost Effective

General Description

The DSC1001/3/4 is a silicon MEMS based CMOS family of oscillators that offers excellent jitter and stability performance over a wide range of supply voltages and temperatures. The device operates from 1 MHz to 150 MHz with supply voltages between 1.8 to 3.3 volts and temperature ranges up to -40°C to 105°C .

The DSC1001/3/4 incorporate an all silicon resonator that is extremely robust and nearly immune to stress related fractures, common to crystal based oscillators. Without sacrificing the performance and stability required of today’s systems, a crystal-less design allows for a higher level of reliability, making the DSC1001/3/4 ideal for rugged, industrial, and portable applications where stress, shock, and vibration can damage quartz crystal based systems.

Available in industry standard packages, the DSC1001/3/4 can be “dropped-in” to the same PCB footprint as standard crystal oscillators.

The DSC1003 and DSC1004 have the same functionality and performance as the DSC1001, but feature higher output drives of 25 pF and 40 pF, respectively.

Package Types

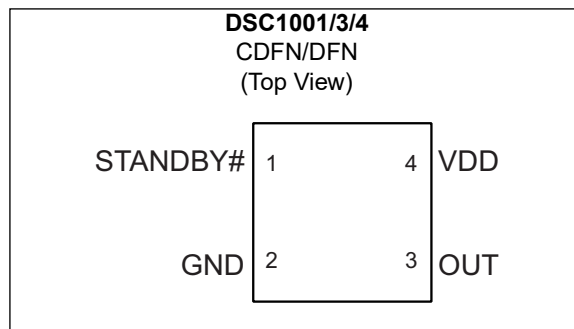

DSC1001/3/4

Block Diagram

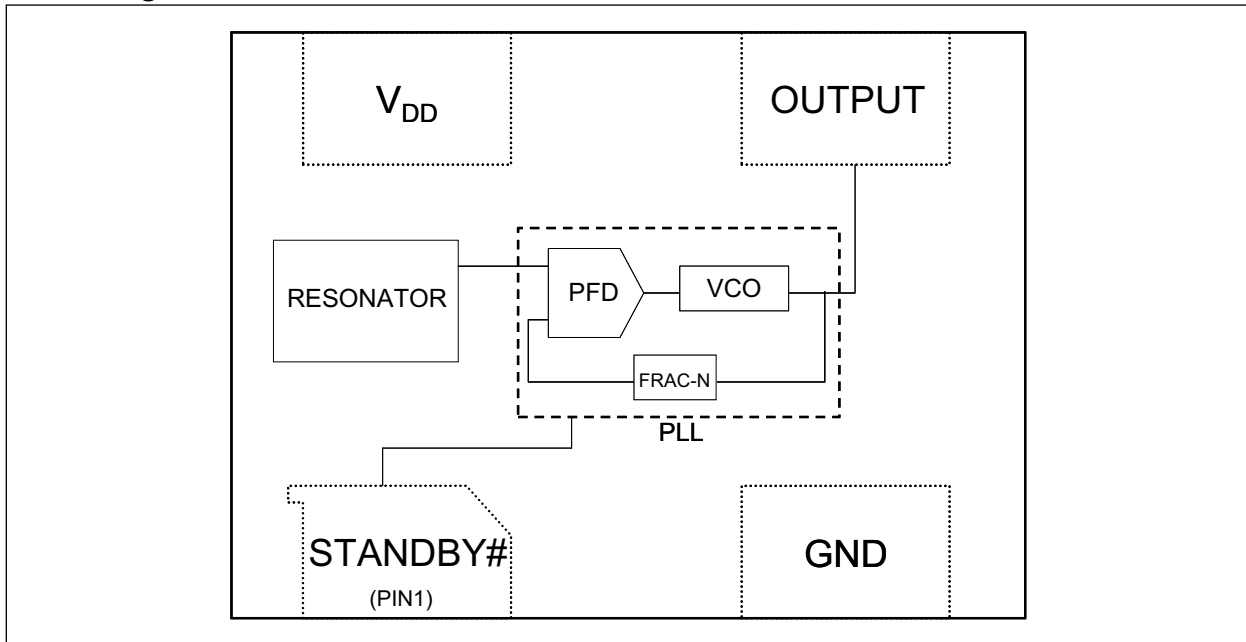

1.0 ELECTRICAL CHARACTERISTICS

Absolute Maximum Ratings †

Input Voltage (V_{IN}) -0.3V to $V_{DD} + 0.3V$
 ESD Protection 4 kV HBM, $\pm 200V$ MM, 1.5 kV CDM

Recommended Operating Conditions

Supply Voltage (V_{DD}) +1.7V to +3.6V
 Output Load (Z_L) $R > 10$ k Ω , $C \leq 15$ pF

† **Notice:** Stresses above those listed under “Absolute Maximum Ratings” may cause permanent damage to the device. This is a stress rating only and functional operation of the device at those or any other conditions above those indicated in the operational sections of this specification is not intended. Exposure to maximum rating conditions for extended periods may affect device reliability.

TABLE 1-1: DC CHARACTERISTICS

Electrical Characteristics: $V_{DD} = 1.8$ to 3.3V; $T_A = +85^\circ C$ unless otherwise specified.

Parameters	Sym.	Min.	Typ.	Max.	Units	Conditions
Frequency	F_0	1	—	150	MHz	Single Frequency
Frequency Tolerance	Δf	—	—	± 10	ppm	Includes frequency variations due to initial tolerance, temperature and power supply voltage
		—	—	± 20		
		—	—	± 25		
		—	—	± 50		
Aging	Δf	—	—	± 5	ppm	1 year @ +25°C
Supply Current, Standby	I_{DD}	—	—	15	μA	$T = +25^\circ C$
Output Startup Time (Note 1)	t_{SU}	—	1.0	1.3	ms	$T = +25^\circ C$
Output Disable Time	t_{DA}	—	20	100	ns	—
Output Duty Cycle	SYM	45	—	55	%	—
Input Logic Level High	V_{IH}	$0.75 \times V_{DD}$	—	—	V	—
Input Logic Level Low	V_{IL}	—	—	$0.25 \times V_{DD}$	V	—
$V_{DD} = 1.8V$						
Supply Current, No Load	I_{DD}	—	6.0	6.3	mA	1 MHz
		—	6.5	7.1		27 MHz
		—	7.2	8.5		70 MHz
		—	8.3	11.9		150 MHz
Output Logic Level High	V_{OH}	$0.8 \times V_{DD}$	—	—	V	-6 mA, DSC1004, $C_L = 40$ pF
		$0.8 \times V_{DD}$	—	—		-6 mA, DSC1003, $C_L = 25$ pF
		$0.8 \times V_{DD}$	—	—		-4 mA, DSC1001, $C_L = 15$ pF
Output Logic Level Low	V_{OL}	—	—	$0.2 \times V_{DD}$	V	6 mA, DSC1004, $C_L = 40$ pF
		—	—	$0.2 \times V_{DD}$		6 mA, DSC1003, $C_L = 25$ pF
		—	—	$0.2 \times V_{DD}$		4 mA, DSC1001, $C_L = 15$ pF

Note 1: t_{SU} is time to stable output frequency after V_{DD} is applied. t_{SU} and t_{EN} (after EN is asserted) are identical values.

2: Measured over 50k clock cycles.

DSC1001/3/4

TABLE 1-1: DC CHARACTERISTICS (CONTINUED)

Electrical Characteristics: $V_{DD} = 1.8$ to $3.3V$; $T_A = +85^\circ C$ unless otherwise specified.

Parameters	Sym.	Min.	Typ.	Max.	Units	Conditions
Output Transition Rise Time	t_R	—	1.4	3.0	ns	DSC1001, $C_L = 15$ pF
		—	1.5	3.0		DSC1003, $C_L = 25$ pF
		—	1.8	3.0		DSC1004, $C_2 = 40$ pF
Output Transition Fall Time	t_F	—	1.0	3.0	ns	DSC1001, $C_L = 15$ pF
		—	1.1	3.0		DSC1003, $C_L = 25$ pF
		—	1.2	3.0		DSC1004, $C_2 = 40$ pF
Jitter, Max. Cycle-to-Cycle	J_{CC}	—	60	—	ps	$f = 100$ MHz (Note 2)
Period Jitter	J_P	—	10	15	ps _{RMS}	$f = 100$ MHz (Note 2)
$V_{DD} = 2.5V$						
Supply Current, No Load	I_{DD}	—	6.0	6.4	mA	1 MHz
		—	6.7	7.5		27 MHz
		—	7.7	9.4		70 MHz
		—	9.6	13.9		150 MHz
Output Logic Level High	V_{OH}	$0.9 \times V_{DD}$	—	—	V	–6 mA, DSC1004, $C_L = 40$ pF
		$0.8 \times V_{DD}$	—	—		–6 mA, DSC1003, $C_L = 25$ pF
		$0.8 \times V_{DD}$	—	—		–4 mA, DSC1001, $C_L = 15$ pF
Output Logic Level Low	V_{OL}	—	—	$0.1 \times V_{DD}$	V	6 mA, DSC1004, $C_L = 40$ pF
		—	—	$0.2 \times V_{DD}$		6 mA, DSC1003, $C_L = 25$ pF
		—	—	$0.2 \times V_{DD}$		4 mA, DSC1001, $C_L = 15$ pF
Output Transition Rise Time	t_R	—	1.0	2.0	ns	DSC1001, $C_L = 15$ pF
		—	1.1	2.0		DSC1003, $C_L = 25$ pF
		—	1.2	2.0		DSC1004, $C_2 = 40$ pF
Output Transition Fall Time	t_F	—	0.9	2.0	ns	DSC1001, $C_L = 15$ pF
		—	1.0	2.0		DSC1003, $C_L = 25$ pF
		—	1.1	2.0		DSC1004, $C_2 = 40$ pF

Note 1: t_{SU} is time to stable output frequency after V_{DD} is applied. t_{SU} and t_{EN} (after EN is asserted) are identical values.

2: Measured over 50k clock cycles.

TABLE 1-1: DC CHARACTERISTICS (CONTINUED)

Electrical Characteristics: $V_{DD} = 1.8$ to $3.3V$; $T_A = +85^\circ C$ unless otherwise specified.

Parameters	Sym.	Min.	Typ.	Max.	Units	Conditions
Jitter, Max. Cycle-to-Cycle	J_{CC}	—	50	—	ps	$f = 100$ MHz (Note 2)
Period Jitter	J_P	—	5	10	ps_{RMS}	$f = 100$ MHz (Note 2)
$V_{DD} = 3.3V$						
Supply Current, No Load	I_{DD}	—	6.0	6.5	mA	1 MHz
		—	6.8	8.0		27 MHz
		—	8.2	10.5		70 MHz
		—	10.8	16.6		150 MHz
$C_L = 0$ pF, $R_L = \infty$, $T = +25^\circ C$						
Output Logic Level High	V_{OH}	$0.9 \times V_{DD}$	—	—	V	-8 mA, DSC1004, $C_L = 40$ pF
		$0.9 \times V_{DD}$	—	—		-6 mA, DSC1003, $C_L = 25$ pF
		$0.8 \times V_{DD}$	—	—		-4 mA, DSC1001, $C_L = 15$ pF
Output Logic Level Low	V_{OL}	—	—	$0.1 \times V_{DD}$	V	8 mA, DSC1004, $C_L = 40$ pF
		—	—	$0.1 \times V_{DD}$		6 mA, DSC1003, $C_L = 25$ pF
		—	—	$0.2 \times V_{DD}$		4 mA, DSC1001, $C_L = 15$ pF
Output Transition Rise Time	t_R	—	1.0	2.0	ns	DSC1001, $C_L = 15$ pF
		—	1.1	2.0		DSC1003, $C_L = 25$ pF
		—	1.2	2.0		DSC1004, $C_2 = 40$ pF
$T = +25^\circ C$, 20% to 80%						
Output Transition Fall Time	t_F	—	0.9	2.0	ns	DSC1001, $C_L = 15$ pF
		—	1.0	2.0		DSC1003, $C_L = 25$ pF
		—	1.1	2.0		DSC1004, $C_2 = 40$ pF
$T = +25^\circ C$, 20% to 80%						
Jitter, Max. Cycle-to-Cycle	J_{CC}	—	50	—	ps	$f = 100$ MHz (Note 2)
Period Jitter	J_P	—	5	10	ps_{RMS}	$f = 100$ MHz (Note 2)

Note 1: t_{SU} is time to stable output frequency after V_{DD} is applied. t_{SU} and t_{EN} (after EN is asserted) are identical values.

2: Measured over 50k clock cycles.

DSC1001/3/4

TEMPERATURE SPECIFICATIONS (Note 1)

Parameters	Sym.	Min.	Typ.	Max.	Units	Conditions
Temperature Ranges						
Operating Temperature Range (T)	T _A	-40	—	+105	°C	Ordering Option L
		-40	—	+85	°C	Ordering Option I
		-20	—	+70	°C	Ordering Option E
Junction Operating Temperature	T _J	—	—	+150	°C	—
Storage Temperature Range	T _A	-55	—	+150	°C	—
Soldering Temperature Range	T _S	—	—	+260	°C	40 sec. max

Note 1: The maximum allowable power dissipation is a function of ambient temperature, the maximum allowable junction temperature and the thermal resistance from junction to air (i.e., T_A, T_J, θ_{JA}). Exceeding the maximum allowable power dissipation will cause the device operating junction temperature to exceed the maximum +150°C rating. Sustained junction temperatures above +150°C can impact the device reliability.

2.0 PIN DESCRIPTIONS

The descriptions of the pins are listed in [Table 2-1](#) and [Table 2-2](#).

TABLE 2-1: CDFN PACKAGE PIN FUNCTION TABLE

Pin Number	Symbol	Description
1	STANDBY#	Standby input (Section 4.1 “Standby Function”)
2	GND	Power supply ground
3	OUT	Oscillator output
4	VDD	Positive power supply

TABLE 2-2: DFN PACKAGE PIN FUNCTION TABLE

Pin Number	Symbol	Description
1	STANDBY#	Standby input (Section 4.1 “Standby Function”)
2	GND	Power supply ground
3	OUT	Oscillator output
4	VDD	Positive power supply
Center Pad	NC	Tie to GND or do not connect.

DSC1001/3/4

3.0 NOMINAL PERFORMANCE CHARACTERISTICS

Note: The graphs and tables provided following this note are a statistical summary based on a limited number of samples and are provided for informational purposes only. The performance characteristics listed herein are not tested or guaranteed. In some graphs or tables, the data presented may be outside the specified operating range (e.g., outside specified power supply range) and therefore outside the warranted range.

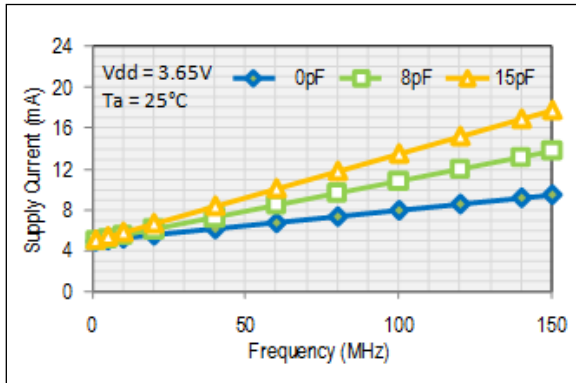

FIGURE 3-1: Supply Current.

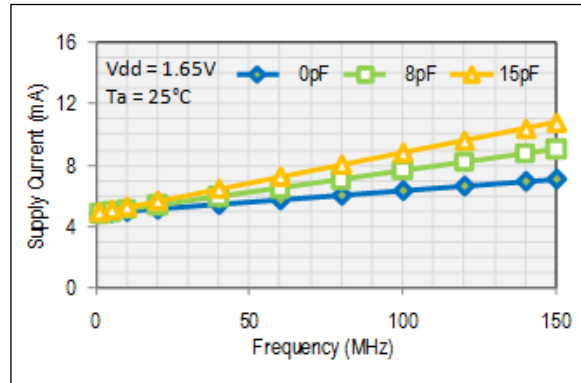

FIGURE 3-4: Supply Current.

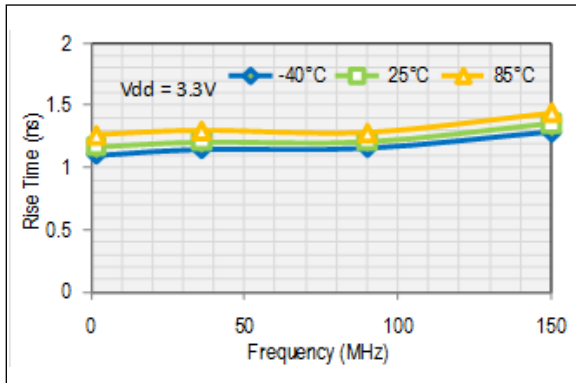

FIGURE 3-2: Rise Time.

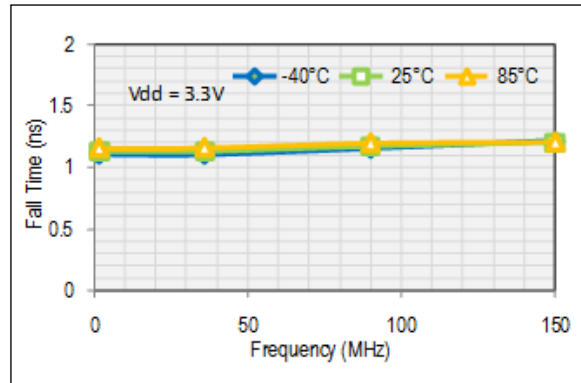

FIGURE 3-5: Fall Time.

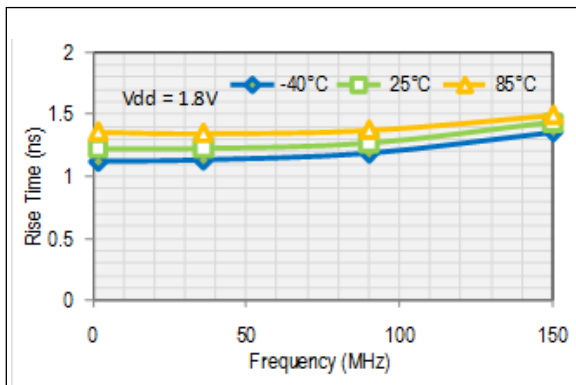

FIGURE 3-3: Rise Time.

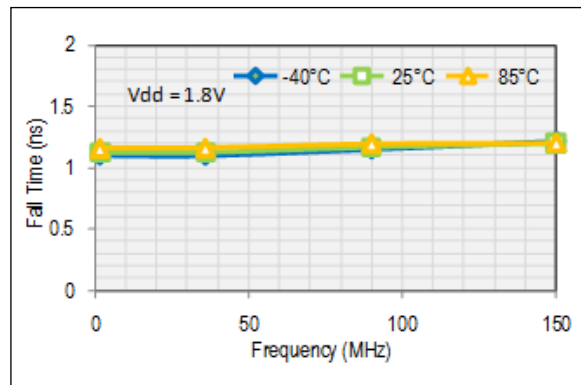

FIGURE 3-6: Fall Time.

4.0 OUTPUT WAVEFORM

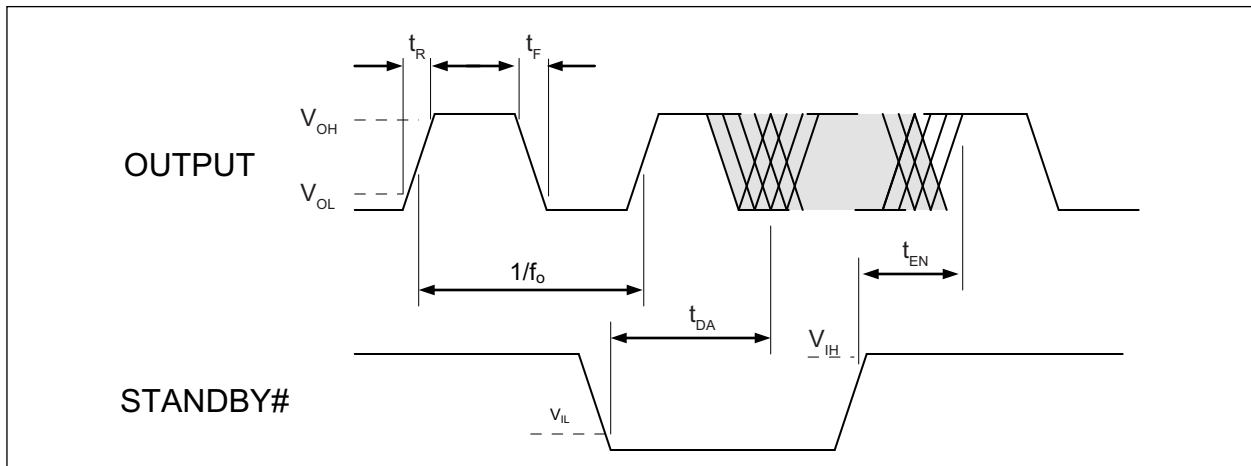

FIGURE 4-1: Output Waveform.

4.1 Standby Function

Standby# (Pin 1)	Output (Pin 3)
High Level	Output ON
Open (no connect)	Output ON
Low Level	High Impedance

DSC1001/3/4

5.0 TEST CIRCUIT

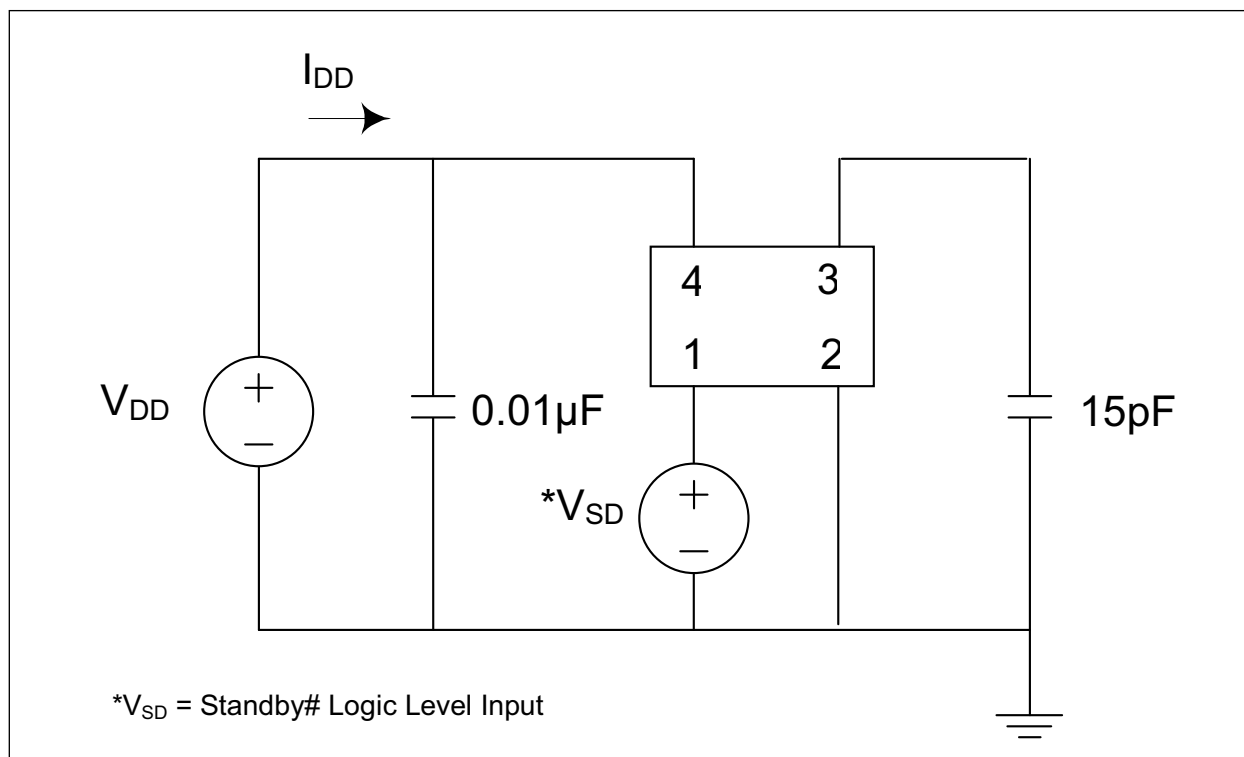

FIGURE 5-1: DSC1001/3/4 Test Circuit.

6.0 BOARD LAYOUT (RECOMMENDED)

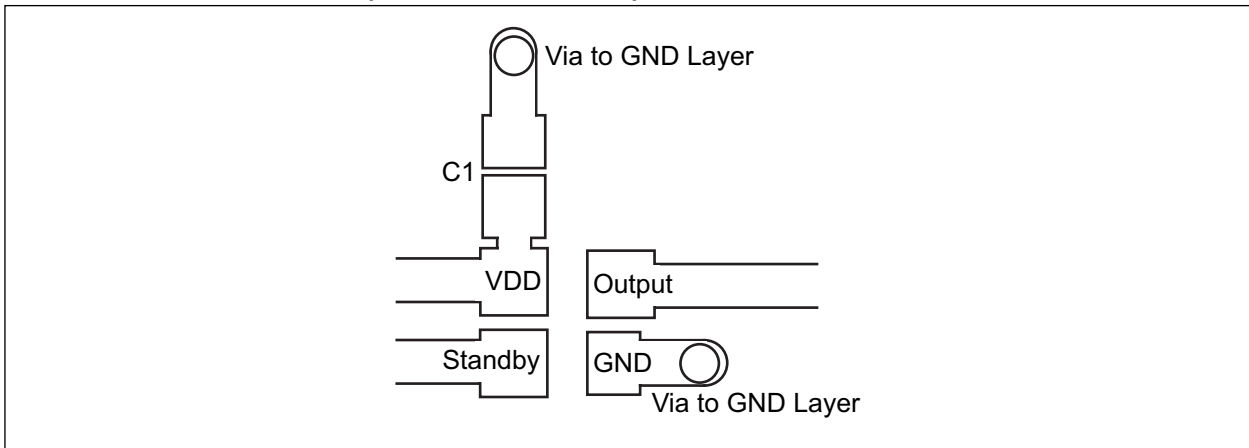

FIGURE 6-1: Recommended Board Layout for DSC1001/3/4.

DSC1001/3/4

7.0 SOLDER REFLOW PROFILE

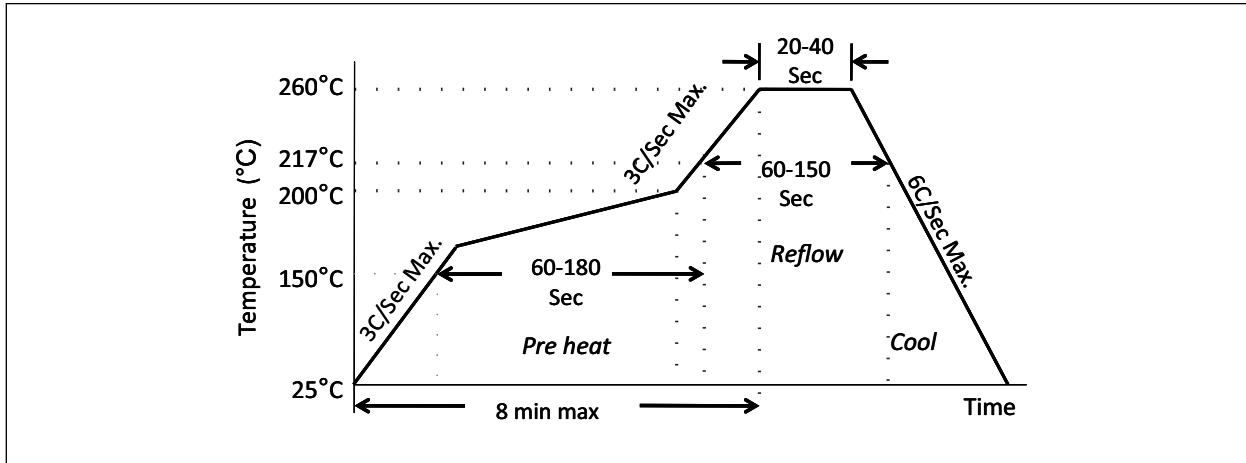

FIGURE 7-1: Solder Reflow Profile.

MSL 1 @ 260°C refer to JSTD-020C	
Ramp-Up Rate (200°C to Peak Temp)	3°C/sec. max.
Preheat Time 150°C to 200°C	60 to 180 sec.
Time maintained above 217°C	60 to 150 sec.
Peak Temperature	255°C to 260°C
Time within 5°C of Actual Peak	20 to 40 sec.
Ramp-Down Rate	6°C/sec. max.
Time 25°C to Peak Temperature	8 minutes max.

8.0 PACKAGING INFORMATION

8.1 Package Marking Information

4-Lead CDFN/DFN*

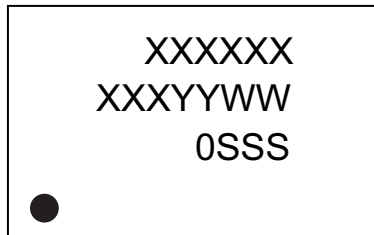

Example

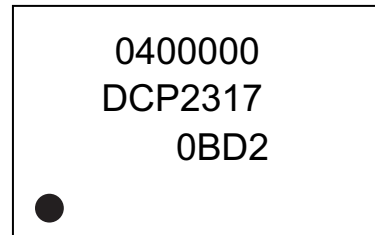

Legend:	XX...X	Product code, customer-specific information, or frequency in MHz without printed decimal point
	Y	Year code (last digit of calendar year)
	YY	Year code (last 2 digits of calendar year)
	WW	Week code (week of January 1 is week '01')
	SSS	Alphanumeric traceability code
	(e3)	Pb-free JEDEC® designator for Matte Tin (Sn)
	* (e3)	This package is Pb-free. The Pb-free JEDEC designator ((e3)) can be found on the outer packaging for this package.
	•, ▲, ▼	Pin one index is identified by a dot, delta up, or delta down (triangle mark).
Note:	In the event the full Microchip part number cannot be marked on one line, it will be carried over to the next line, thus limiting the number of available characters for customer-specific information. Package may or may not include the corporate logo.	
	Underbar (¯) and/or Overbar (¯) symbol may not be to scale.	

DSC1001/3/4

4-Lead DFN 7.0 mm x 5.0 mm Package Outline & Recommended Land Pattern

TITLE

4 LEAD DFN 7.0x5.0mm PACKAGE OUTLINE & RECOMMENDED LAND PATTERN

DRAWING #	DFN75-4LD-PL-1	UNIT	MM
-----------	----------------	------	----

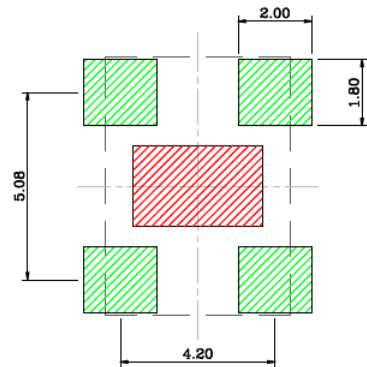
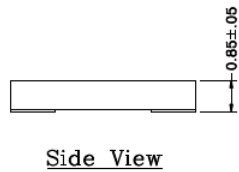
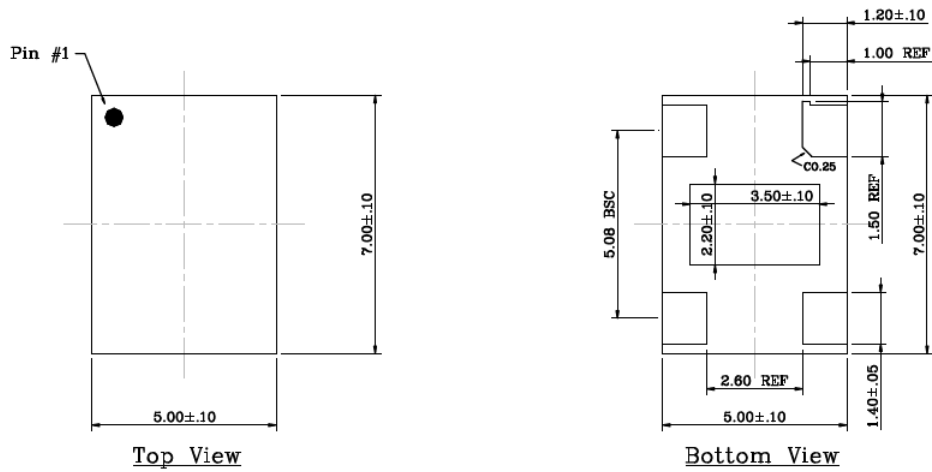

Recommended Land Pattern

NOTE:

1. Green shaded rectangles in Recommended Land Pattern are solder stencil opening.
2. Red shaded rectangle in Recommended Land Pattern is keep out area.

Note: For the most current package drawings, please see the Microchip Packaging Specification located at <http://www.microchip.com/packaging>.

4-Lead CDFN 5.0 mm x 3.2 mm Package Outline & Recommended Land Pattern

TITLE

4 LEAD CDFN 5.0x3.2mm COL PACKAGE OUTLINE & RECOMMENDED LAND PATTERN

DRAWING #	CDFN5032-4LD-PL-1	UNIT	MM
-----------	-------------------	------	----

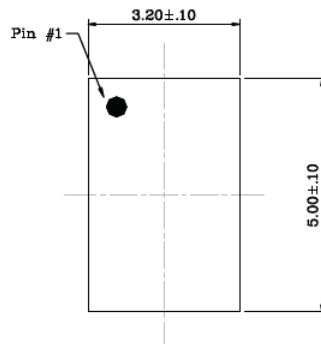

Top View

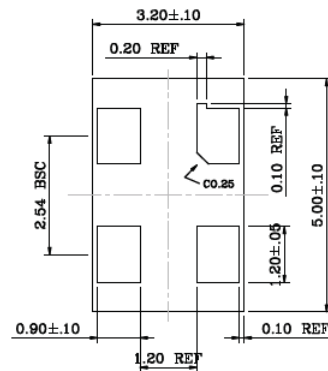

Bottom View

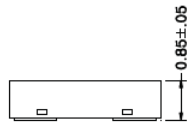

Side View

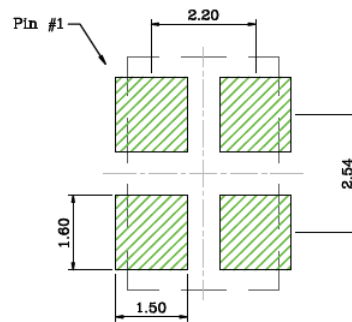

Recommended Land Pattern

NOTE:

- Green shaded rectangles in Recommended Land Pattern are solder stencil opening.

Note: For the most current package drawings, please see the Microchip Packaging Specification located at <http://www.microchip.com/packaging>.

DSC1001/3/4

4-Lead CDFN 3.2 mm x 2.5 mm Package Outline & Recommended Land Pattern

TITLE

4 LEAD CDFN 3.2x2.5mm COL PACKAGE OUTLINE & RECOMMENDED LAND PATTERN

DRAWING #	CDFN3225-4LD-PL-1	UNIT	MM
-----------	-------------------	------	----

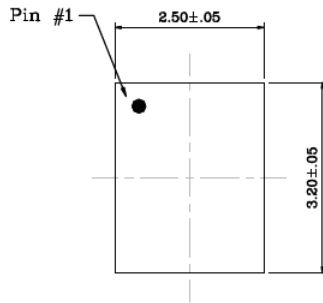

Top View

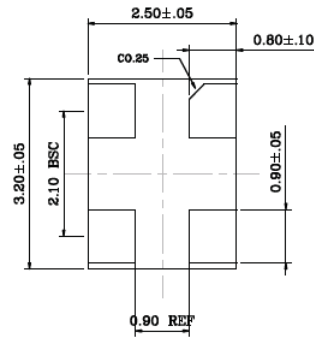

Bottom View

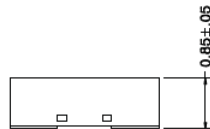

Side View

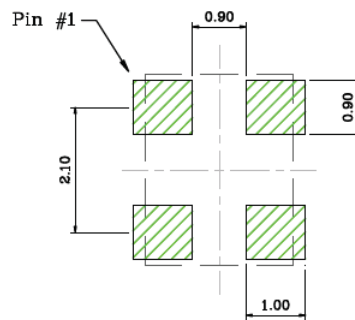

Recommended Land Pattern

NOTE:

1. Green shaded rectangles in Recommended Land Pattern are solder stencil opening.

Note: For the most current package drawings, please see the Microchip Packaging Specification located at <http://www.microchip.com/packaging>.

4-Lead CDFN 2.5 mm x 2.0 mm Package Outline & Recommended Land Pattern

TITLE

4 LEAD CDFN 2.5x2.0mm COL PACKAGE OUTLINE & RECOMMENDED LAND PATTERN

DRAWING #	CDFN2520-4LD-PL-1	UNIT	MM
-----------	-------------------	------	----

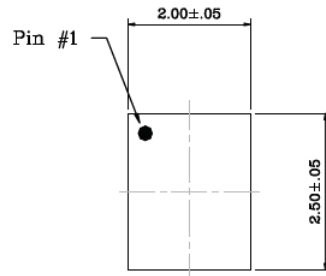

Top View

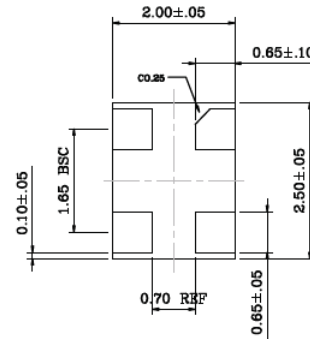

Bottom View



Side View

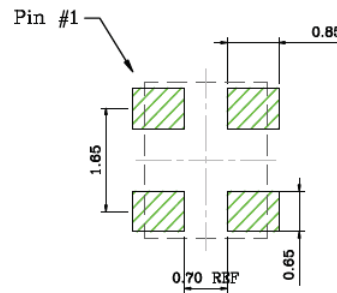

Recommended Land Pattern

NOTE:

- Green shaded rectangles in Recommended Land Pattern are solder stencil opening.

Note: For the most current package drawings, please see the Microchip Packaging Specification located at <http://www.microchip.com/packaging>.

DSC1001/3/4

NOTES:

APPENDIX A: REVISION HISTORY

Revision A (September 2017)

- Converted Micrel data sheet DSC1001 to Microchip format data sheet DS20005529A.
- Minor text changes throughout.
- Added [Table 2-2](#) for DFN package.
- Combined Micrel data sheet DSC1003 and DSC1004 into this data sheet.
 - Updated [Section 1.0 “Electrical Characteristics”](#) to reflect this change.
 - Updated [General Description](#) and [Features](#) to reflect this change.

Revision B (November 2017)

- Updated V_{OH} and V_{OL} values in [Table 1-1](#).

Revision C (July 2023)

- Updated the [Package Marking Information](#) drawing.

DSC1001/3/4

NOTES:

PRODUCT IDENTIFICATION SYSTEM

To order or obtain information, e.g., on pricing or delivery, contact your local Microchip representative or sales office.

PART NO.		X	X	X	-XXX.XXXX	X																																					
Device	Package	Temperature Range	Stability	Frequency	Package																																						
<p>Device: DSC1001/3/4: 1.8V - 3.3V Low-Power Precision CMOS Oscillator</p> <p>Package:</p> <table> <tr><td>A</td><td>=</td><td>4-Lead 7.0 mm x 5.0 mm DFN</td></tr> <tr><td>B</td><td>=</td><td>4-Lead 5.0 mm x 3.2 mm CDFN</td></tr> <tr><td>C</td><td>=</td><td>4-Lead 3.2 mm x 2.5 mm CDFN</td></tr> <tr><td>D</td><td>=</td><td>4-Lead 2.5 mm x 2.0 mm CDFN</td></tr> </table> <p>Temperature Range:</p> <table> <tr><td>E</td><td>=</td><td>-20°C to +70°C (Extended Commercial)</td></tr> <tr><td>I</td><td>=</td><td>-40°C to +85°C (Industrial)</td></tr> <tr><td>L</td><td>=</td><td>-40°C to +105°C (Extended Industrial)</td></tr> </table> <p>Stability:</p> <table> <tr><td>1</td><td>=</td><td>±50ppm</td></tr> <tr><td>2</td><td>=</td><td>±25ppm</td></tr> <tr><td>3</td><td>=</td><td>±20 ppm</td></tr> <tr><td>5</td><td>=</td><td>±10 ppm</td></tr> </table> <p>Frequency: xxx.xxxx = 1 MHz to 150 MHz (user-defined)</p> <p>Packing Option:</p> <table> <tr><td><blank>=</td><td>110/Tube</td></tr> <tr><td>T</td><td>= 1,000/Reel</td></tr> </table>							A	=	4-Lead 7.0 mm x 5.0 mm DFN	B	=	4-Lead 5.0 mm x 3.2 mm CDFN	C	=	4-Lead 3.2 mm x 2.5 mm CDFN	D	=	4-Lead 2.5 mm x 2.0 mm CDFN	E	=	-20°C to +70°C (Extended Commercial)	I	=	-40°C to +85°C (Industrial)	L	=	-40°C to +105°C (Extended Industrial)	1	=	±50ppm	2	=	±25ppm	3	=	±20 ppm	5	=	±10 ppm	<blank>=	110/Tube	T	= 1,000/Reel
A	=	4-Lead 7.0 mm x 5.0 mm DFN																																									
B	=	4-Lead 5.0 mm x 3.2 mm CDFN																																									
C	=	4-Lead 3.2 mm x 2.5 mm CDFN																																									
D	=	4-Lead 2.5 mm x 2.0 mm CDFN																																									
E	=	-20°C to +70°C (Extended Commercial)																																									
I	=	-40°C to +85°C (Industrial)																																									
L	=	-40°C to +105°C (Extended Industrial)																																									
1	=	±50ppm																																									
2	=	±25ppm																																									
3	=	±20 ppm																																									
5	=	±10 ppm																																									
<blank>=	110/Tube																																										
T	= 1,000/Reel																																										
<p>Examples:</p> <p>a) DSC1001AE1-010.0000T: 1.8V - 3.3V Low-Power Precision CMOS Oscillator, 4-Lead 7.0 mm x 5.0 mm DFN, Ext. Commercial Temperature Range, ±50 ppm, 10 MHz Output Frequency, 1,000/Reel</p> <p>b) DSC1003BL2-030.0000: 1.8V - 3.3V Low-Power Precision CMOS Oscillator, 4-Lead 5.0 mm x 3.2 mm CDFN, Ext. Industrial Temperature Range, ±25 ppm, 30 MHz Output Frequency, 110/Tube</p> <p>c) DSC1001DE5-150.0000: 1.8V - 3.3V Low-Power Precision CMOS Oscillator, 4-Lead 2.5 mm x 2.0 mm CDFN, Ext. Commercial Temperature Range, ±10 ppm, 150 MHz Output Frequency, 110/Tube</p> <p>d) DSC1004AI3-075.0000T: 1.8V - 3.3V Low-Power Precision CMOS Oscillator, 4-Lead 7.0 mm x 5.0 mm DFN, Industrial Temperature Range, ±20 ppm, 75 MHz Output Frequency, 1,000/Reel</p> <p>Note 1: Tape and Reel identifier only appears in the catalog part number description. This identifier is used for ordering purposes and is not printed on the device package. Check with your Microchip Sales Office for package availability with the Tape and Reel option.</p>																																											

DSC1001/3/4

NOTES:

Note the following details of the code protection feature on Microchip products:

- Microchip products meet the specifications contained in their particular Microchip Data Sheet.
- Microchip believes that its family of products is secure when used in the intended manner, within operating specifications, and under normal conditions.
- Microchip values and aggressively protects its intellectual property rights. Attempts to breach the code protection features of Microchip product is strictly prohibited and may violate the Digital Millennium Copyright Act.
- Neither Microchip nor any other semiconductor manufacturer can guarantee the security of its code. Code protection does not mean that we are guaranteeing the product is "unbreakable" Code protection is constantly evolving. Microchip is committed to continuously improving the code protection features of our products.

This publication and the information herein may be used only with Microchip products, including to design, test, and integrate Microchip products with your application. Use of this information in any other manner violates these terms. Information regarding device applications is provided only for your convenience and may be superseded by updates. It is your responsibility to ensure that your application meets with your specifications. Contact your local Microchip sales office for additional support or, obtain additional support at <https://www.microchip.com/en-us/support/design-help/client-support-services>.

THIS INFORMATION IS PROVIDED BY MICROCHIP "AS IS". MICROCHIP MAKES NO REPRESENTATIONS OR WARRANTIES OF ANY KIND WHETHER EXPRESS OR IMPLIED, WRITTEN OR ORAL, STATUTORY OR OTHERWISE, RELATED TO THE INFORMATION INCLUDING BUT NOT LIMITED TO ANY IMPLIED WARRANTIES OF NON-INFRINGEMENT, MERCHANTABILITY, AND FITNESS FOR A PARTICULAR PURPOSE, OR WARRANTIES RELATED TO ITS CONDITION, QUALITY, OR PERFORMANCE.

IN NO EVENT WILL MICROCHIP BE LIABLE FOR ANY INDIRECT, SPECIAL, PUNITIVE, INCIDENTAL, OR CONSEQUENTIAL LOSS, DAMAGE, COST, OR EXPENSE OF ANY KIND WHATSOEVER RELATED TO THE INFORMATION OR ITS USE, HOWEVER CAUSED, EVEN IF MICROCHIP HAS BEEN ADVISED OF THE POSSIBILITY OR THE DAMAGES ARE FORESEEABLE. TO THE FULLEST EXTENT ALLOWED BY LAW, MICROCHIP'S TOTAL LIABILITY ON ALL CLAIMS IN ANY WAY RELATED TO THE INFORMATION OR ITS USE WILL NOT EXCEED THE AMOUNT OF FEES, IF ANY, THAT YOU HAVE PAID DIRECTLY TO MICROCHIP FOR THE INFORMATION.

Use of Microchip devices in life support and/or safety applications is entirely at the buyer's risk, and the buyer agrees to defend, indemnify and hold harmless Microchip from any and all damages, claims, suits, or expenses resulting from such use. No licenses are conveyed, implicitly or otherwise, under any Microchip intellectual property rights unless otherwise stated.

For information regarding Microchip's Quality Management Systems, please visit www.microchip.com/quality.

Trademarks

The Microchip name and logo, the Microchip logo, Adaptec, AVR, AVR logo, AVR Freaks, BesTime, BitCloud, CryptoMemory, CryptoRF, dsPIC, flexPWR, HELDO, IGL00, JukeBlox, KeeLoq, Klear, LANCheck, LinkMD, maXStylus, maXTouch, MediaLB, megaAVR, Microsemi, Microsemi logo, MOST, MOST logo, MPLAB, OptoLyzer, PIC, picoPower, PICSTART, PIC32 logo, PolarFire, Prochip Designer, QTouch, SAM-BA, SenGenuity, SpyNIC, SST, SST Logo, SuperFlash, Symmetricom, SyncServer, Tachyon, TimeSource, tinyAVR, UNI/O, Vectron, and XMEGA are registered trademarks of Microchip Technology Incorporated in the U.S.A. and other countries.

AgileSwitch, APT, ClockWorks, The Embedded Control Solutions Company, EtherSynch, Flashtec, Hyper Speed Control, HyperLight Load, Libero, motorBench, mTouch, Powermite 3, Precision Edge, ProASIC, ProASIC Plus, ProASIC Plus logo, Quiet-Wire, SmartFusion, SyncWorld, Temux, TimeCesium, TimeHub, TimePictra, TimeProvider, TrueTime, and ZL are registered trademarks of Microchip Technology Incorporated in the U.S.A.

Adjacent Key Suppression, AKS, Analog-for-the-Digital Age, Any Capacitor, AnyIn, AnyOut, Augmented Switching, BlueSky, BodyCom, Clockstudio, CodeGuard, CryptoAuthentication, CryptoAutomotive, CryptoCompanion, CryptoController, dsPICDEM, dsPICDEM.net, Dynamic Average Matching, DAM, ECAN, Espresso T1S, EtherGREEN, GridTime, IdealBridge, In-Circuit Serial Programming, ICSP, INICnet, Intelligent Paralleling, IntelliMOS, Inter-Chip Connectivity, JitterBlocker, Knob-on-Display, KoD, maxCrypto, maxView, memBrain, Mindi, MiWi, MPASM, MPF, MPLAB Certified logo, MPLIB, MPLINK, MultiTRAK, NetDetach, Omniscient Code Generation, PICDEM, PICDEM.net, PICkit, PICtail, PowerSmart, PureSilicon, QMatrix, REAL ICE, Ripple Blocker, RTAX, RTG4, SAM-ICE, Serial Quad I/O, simpleMAP, SimpliPHY, SmartBuffer, SmartHLS, SMART-I.S., storClad, SQI, SuperSwitcher, SuperSwitcher II, Switchtec, SynchroPHY, Total Endurance, Trusted Time, TSHARC, USBCheck, VariSense, VectorBlox, VeriPHY, ViewSpan, WiperLock, XpressConnect, and ZENA are trademarks of Microchip Technology Incorporated in the U.S.A. and other countries.

SQTP is a service mark of Microchip Technology Incorporated in the U.S.A.

The Adaptec logo, Frequency on Demand, Silicon Storage Technology, and Symmcom are registered trademarks of Microchip Technology Inc. in other countries.

GestIC is a registered trademark of Microchip Technology Germany II GmbH & Co. KG, a subsidiary of Microchip Technology Inc., in other countries.

All other trademarks mentioned herein are property of their respective companies.

© 2017 - 2023, Microchip Technology Incorporated and its subsidiaries.

All Rights Reserved.

ISBN: 978-1-6683-2904-7



MICROCHIP

Worldwide Sales and Service

AMERICAS

Corporate Office
2355 West Chandler Blvd.
Chandler, AZ 85224-6199
Tel: 480-792-7200
Fax: 480-792-7277
Technical Support:
<http://www.microchip.com/support>
Web Address:
www.microchip.com

Atlanta

Duluth, GA
Tel: 678-957-9614
Fax: 678-957-1455

Austin, TX

Tel: 512-257-3370

Boston

Westborough, MA
Tel: 774-760-0087
Fax: 774-760-0088

Chicago

Itasca, IL
Tel: 630-285-0071
Fax: 630-285-0075

Dallas

Addison, TX
Tel: 972-818-7423
Fax: 972-818-2924

Detroit

Novi, MI
Tel: 248-848-4000

Houston, TX

Tel: 281-894-5983

Indianapolis

Noblesville, IN
Tel: 317-773-8323
Fax: 317-773-5453
Tel: 317-536-2380

Los Angeles

Mission Viejo, CA
Tel: 949-462-9523
Fax: 949-462-9608
Tel: 951-273-7800

Raleigh, NC

Tel: 919-844-7510

New York, NY

Tel: 631-435-6000

San Jose, CA

Tel: 408-735-9110
Tel: 408-436-4270

Canada - Toronto

Tel: 905-695-1980
Fax: 905-695-2078

ASIA/PACIFIC

Australia - Sydney
Tel: 61-2-9868-6733

China - Beijing
Tel: 86-10-8569-7000

China - Chengdu
Tel: 86-28-8665-5511

China - Chongqing
Tel: 86-23-8980-9588

China - Dongguan
Tel: 86-769-8702-9880

China - Guangzhou
Tel: 86-20-8755-8029

China - Hangzhou
Tel: 86-571-8792-8115

China - Hong Kong SAR
Tel: 852-2943-5100

China - Nanjing
Tel: 86-25-8473-2460

China - Qingdao
Tel: 86-532-8502-7355

China - Shanghai
Tel: 86-21-3326-8000

China - Shenyang
Tel: 86-24-2334-2829

China - Shenzhen
Tel: 86-755-8864-2200

China - Suzhou
Tel: 86-186-6233-1526

China - Wuhan
Tel: 86-27-5980-5300

China - Xian
Tel: 86-29-8833-7252

China - Xiamen
Tel: 86-592-2388138

China - Zhuhai
Tel: 86-756-3210040

ASIA/PACIFIC

India - Bangalore
Tel: 91-80-3090-4444

India - New Delhi
Tel: 91-11-4160-8631

India - Pune
Tel: 91-20-4121-0141

Japan - Osaka
Tel: 81-6-6152-7160

Japan - Tokyo
Tel: 81-3-6880-3770

Korea - Daegu
Tel: 82-53-744-4301

Korea - Seoul
Tel: 82-2-554-7200

Malaysia - Kuala Lumpur
Tel: 60-3-7651-7906

Malaysia - Penang
Tel: 60-4-227-8870

Philippines - Manila
Tel: 63-2-634-9065

Singapore
Tel: 65-6334-8870

Taiwan - Hsin Chu
Tel: 886-3-577-8366

Taiwan - Kaohsiung
Tel: 886-7-213-7830

Taiwan - Taipei
Tel: 886-2-2508-8600

Thailand - Bangkok
Tel: 66-2-694-1351

Vietnam - Ho Chi Minh
Tel: 84-28-5448-2100

EUROPE

Austria - Wels
Tel: 43-7242-2244-39
Fax: 43-7242-2244-393

Denmark - Copenhagen
Tel: 45-4485-5910
Fax: 45-4485-2829

Finland - Espoo
Tel: 358-9-4520-820

France - Paris
Tel: 33-1-69-53-63-20
Fax: 33-1-69-30-90-79

Germany - Garching
Tel: 49-8931-9700

Germany - Haan
Tel: 49-2129-3766400

Germany - Heilbronn
Tel: 49-7131-72400

Germany - Karlsruhe
Tel: 49-721-625370

Germany - Munich
Tel: 49-89-627-144-0
Fax: 49-89-627-144-44

Germany - Rosenheim
Tel: 49-8031-354-560

Israel - Ra'anana
Tel: 972-9-744-7705

Italy - Milan
Tel: 39-0331-742611
Fax: 39-0331-466781

Italy - Padova
Tel: 39-049-7625286

Netherlands - Drunen
Tel: 31-416-690399
Fax: 31-416-690340

Norway - Trondheim
Tel: 47-7288-4388

Poland - Warsaw
Tel: 48-22-3325737

Romania - Bucharest
Tel: 40-21-407-87-50

Spain - Madrid
Tel: 34-91-708-08-90
Fax: 34-91-708-08-91

Sweden - Gothenberg
Tel: 46-31-704-60-40

Sweden - Stockholm
Tel: 46-8-5090-4654

UK - Wokingham
Tel: 44-118-921-5800
Fax: 44-118-921-5820