

RA6M3 Group

AI Kit for RA6M3 Microcontroller Group
AIK-RA6M3 v1
User's Manual

Renesas RA Family
RA6M Series

All information contained in these materials, including products and product specifications, represents information on the product at the time of publication and is subject to change by Renesas Electronics Corp. without notice. Please review the latest information published by Renesas Electronics Corp. through various means, including the Renesas Electronics Corp. website (<http://www.renesas.com>).

Notice

1. Descriptions of circuits, software and other related information in this document are provided only to illustrate the operation of semiconductor products and application examples. You are fully responsible for the incorporation or any other use of the circuits, software, and information in the design of your product or system. Renesas Electronics disclaims any and all liability for any losses and damages incurred by you or third parties arising from the use of these circuits, software, or information.
 2. Renesas Electronics hereby expressly disclaims any warranties against and liability for infringement or any other claims involving patents, copyrights, or other intellectual property rights of third parties, by or arising from the use of Renesas Electronics products or technical information described in this document, including but not limited to, the product data, drawings, charts, programs, algorithms, and application examples.
 3. No license, express, implied or otherwise, is granted hereby under any patents, copyrights or other intellectual property rights of Renesas Electronics or others.
 4. You shall not alter, modify, copy, or reverse engineer any Renesas Electronics product, whether in whole or in part. Renesas Electronics disclaims any and all liability for any losses or damages incurred by you or third parties arising from such alteration, modification, copying or reverse engineering.
 5. Renesas Electronics products are classified according to the following two quality grades: "Standard" and "High Quality". The intended applications for each Renesas Electronics product depends on the product's quality grade, as indicated below.
 - "Standard": Computers; office equipment; communications equipment; test and measurement equipment; audio and visual equipment; home electronic appliances; machine tools; personal electronic equipment; industrial robots; etc.
 - "High Quality": Transportation equipment (automobiles, trains, ships, etc.); traffic control (traffic lights); large-scale communication equipment; key financial terminal systems; safety control equipment; etc.
- Unless expressly designated as a high reliability product or a product for harsh environments in a Renesas Electronics data sheet or other Renesas Electronics document, Renesas Electronics products are not intended or authorized for use in products or systems that may pose a direct threat to human life or bodily injury (artificial life support devices or systems; surgical implantations; etc.), or may cause serious property damage (space system; undersea repeaters; nuclear power control systems; aircraft control systems; key plant systems; military equipment; etc.). Renesas Electronics disclaims any and all liability for any damages or losses incurred by you or any third parties arising from the use of any Renesas Electronics product that is inconsistent with any Renesas Electronics data sheet, user's manual or other Renesas Electronics document.
6. When using Renesas Electronics products, refer to the latest product information (data sheets, user's manuals, application notes, "General Notes for Handling and Using Semiconductor Devices" in the reliability handbook, etc.), and ensure that usage conditions are within the ranges specified by Renesas Electronics with respect to maximum ratings, operating power supply voltage range, heat dissipation characteristics, installation, etc. Renesas Electronics disclaims any and all liability for any malfunctions, failure or accident arising out of the use of Renesas Electronics products outside of such specified ranges.
 7. Although Renesas Electronics endeavors to improve the quality and reliability of Renesas Electronics products, semiconductor products have specific characteristics, such as the occurrence of failure at a certain rate and malfunctions under certain use conditions. Unless designated as a high reliability product or a product for harsh environments in a Renesas Electronics data sheet or other Renesas Electronics document, Renesas Electronics products are not subject to radiation resistance design. You are responsible for implementing safety measures to guard against the possibility of bodily injury, injury or damage caused by fire, and/or danger to the public in the event of a failure or malfunction of Renesas Electronics products, such as safety design for hardware and software, including but not limited to redundancy, fire control and malfunction prevention, appropriate treatment for aging degradation or any other appropriate measures. Because the evaluation of microcomputer software alone is very difficult and impractical, you are responsible for evaluating the safety of the final products or systems manufactured by you.
 8. Please contact a Renesas Electronics sales office for details as to environmental matters such as the environmental compatibility of each Renesas Electronics product. You are responsible for carefully and sufficiently investigating applicable laws and regulations that regulate the inclusion or use of controlled substances, including without limitation, the EU RoHS Directive, and using Renesas Electronics products in compliance with all these applicable laws and regulations. Renesas Electronics disclaims any and all liability for damages or losses occurring as a result of your noncompliance with applicable laws and regulations.
 9. Renesas Electronics products and technologies shall not be used for or incorporated into any products or systems whose manufacture, use, or sale is prohibited under any applicable domestic or foreign laws or regulations. You shall comply with any applicable export control laws and regulations promulgated and administered by the governments of any countries asserting jurisdiction over the parties or transactions.
 10. It is the responsibility of the buyer or distributor of Renesas Electronics products, or any other party who distributes, disposes of, or otherwise sells or transfers the product to a third party, to notify such third party in advance of the contents and conditions set forth in this document.
 11. This document shall not be reprinted, reproduced or duplicated in any form, in whole or in part, without prior written consent of Renesas Electronics.
 12. Please contact a Renesas Electronics sales office if you have any questions regarding the information contained in this document or Renesas Electronics products.

(Note1) "Renesas Electronics" as used in this document means Renesas Electronics Corporation and also includes its directly or indirectly controlled subsidiaries.

(Note2) "Renesas Electronics product(s)" means any product developed or manufactured by or for Renesas Electronics.

(Rev.4.0-1 November 2017)

Corporate Headquarters

TOYOSU FORESIA, 3-2-24 Toyosu,
Koto-ku, Tokyo 135-0061, Japan
www.renesas.com

Trademarks

Renesas and the Renesas logo are trademarks of Renesas Electronics Corporation. All trademarks and registered trademarks are the property of their respective owners.

Contact information

For further information on a product, technology, the most up-to-date version of a document, or your nearest sales office, please visit:
www.renesas.com/contact/.

Renesas AIK-RA6M3 Disclaimer

By using this AIK-RA6M3, the User accepts the following terms, which are in addition to, and control in the event of disagreement, with Renesas' General Terms and Conditions available at <https://www.renesas.com/en-us/legal/disclaimer.html>.

The AIK-RA6M3 is not guaranteed to be error free, and the entire risk as to the results and performance of the AIK-RA6M3 is assumed by the User. The AIK-RA6M3 is provided by Renesas on an "as is" basis without warranty of any kind whether express or implied, including but not limited to the implied warranties of good workmanship, fitness for a particular purpose, title, merchantability, and non-infringement of intellectual property rights. Renesas expressly disclaims any implied warranty.

Renesas does not consider the AIK-RA6M3 to be a finished product and therefore the AIK-RA6M3 may not comply with some requirements applicable to finished products, including, but not limited to recycling, restricted substances and electromagnetic compatibility regulations. Refer to Certifications section, for information about certifications and compliance information for the AIK-RA6M3. It is the kit User's responsibility to make sure the kit meets any local requirements applicable to their region.

Renesas or its affiliates shall in no event be liable for any loss of profit, loss of data, loss of contract, loss of business, damage to reputation or goodwill, any economic loss, any reprogramming or recall costs (whether the foregoing losses are direct or indirect) nor shall Renesas or its affiliates be liable for any other direct or indirect special, incidental or consequential damages arising out of or in relation to the use of this AIK-RA6M3, even if Renesas or its affiliates have been advised of the possibility of such damages.

Renesas has used reasonable care in preparing the information included in this document, but Renesas does not warrant that such information is error free nor does Renesas guarantee an exact match for every application or parameter to part numbers designated by other vendors listed herein. The information provided in this document is intended solely to enable the use of Renesas products. No express or implied license to any intellectual property right is granted by this document or in connection with the sale of Renesas products. Renesas reserves the right to make changes to specifications and product descriptions at any time without notice. Renesas assumes no liability for any damages incurred by you resulting from errors in or omissions from the information included herein. Renesas cannot verify, and assumes no liability for, the accuracy of information available on another company's website.

Precautions

This AI Kit is only intended for use in a laboratory environment under ambient temperature and humidity conditions. A safe separation distance should be used between this and any sensitive equipment. Its use outside the laboratory, classroom, study area, or similar such area invalidates conformity with the protection requirements of the Electromagnetic Compatibility Directive and could lead to prosecution.

The product generates, uses, and can radiate radio frequency energy and may cause harmful interference to radio communications. There is no guarantee that interference will not occur in a particular installation. If this equipment causes harmful interference to radio or television reception, which can be determined by turning the equipment off or on, you are encouraged to try to correct the interference by one or more of the following measures:

- Ensure attached cables do not lie across the equipment.
- Reorient the receiving antenna.
- Increase the distance between the equipment and the receiver.
- Connect the equipment into an outlet on a circuit different from that which the receiver is connected.
- Power down the equipment when not in use.
- Consult the dealer or an experienced radio/TV technician for help.

Note: It is recommended that wherever possible shielded interface cables are used.

The product is potentially susceptible to certain EMC phenomena. To mitigate against them it is recommended that the following measures be undertaken:

- The user is advised that mobile phones should not be used within 10 m of the product when in use.
- The user is advised to take ESD precautions when handling the equipment.

The AI Kit does not represent an ideal reference design for an end product and does not fulfill the regulatory standards for an end product.

Renesas RA Family

AIK-RA6M3 v1
Contents

1. Kit Overview	3
1.1 Assumptions and Advisory Notes.....	5
2. Kit Contents	6
3. Ordering Information.....	6
4. Getting Started with Embedded Software Development Using the AIK-RA6M3.....	6
4.1 Installing the Flexible Software Package and Development Tools	6
4.1.1 Useful Tips.....	6
4.1.2 Quick Setup Guide for RA MCUs	7
5. Hardware Details	8
5.1 Kit Architecture	8
5.1.1 System Block Diagram	9
5.2 General Features.....	9
5.2.1 Jumper Settings.....	9
5.2.2 Power Requirements.....	9
5.2.3 MCU Boot Mode	11
5.2.4 Debug Interface	11
5.2.5 USB Full Speed	13
5.2.6 PMOD 1	13
5.2.7 PMOD 2.....	14
5.2.8 PMOD 3.....	15
5.2.9 PMOD 4.....	15
5.2.10 PMOD 5.....	16
5.2.11 PMOD 6.....	17
5.2.12 LEDs.....	18
5.2.13 Switches	18
5.3 Special Features Access.....	20
5.3.1 Ethernet	20
5.3.2 MICS.....	20
5.3.3 CAN/CAN-FD	21
5.3.4 Camera Module Socket.....	21
6. Certifications.....	23
6.1 EMC/EMI Standards.....	23
6.2 Material Selection, Waste, Recycling and Disposal Standards	23

6.3	Safety Standards	23
7.	Design and Manufacturing Information	23
8.	Website and Support	24
	Revision History	25

Figures

Figure 1.	AIK-RA6M3 Top Side	4
Figure 2.	AIK-RA6M3 Bottom Side	4
Figure 3.	Kit Contents	6
Figure 4.	AIK- RA6M3 Board	8
Figure 5.	AIK-RA6M3 Block Diagram	9
Figure 6.	Power Supply Options	10
Figure 7.	AIK-RA6M3 Debug Interface	11
Figure 8.	USB Full Speed Connector	13
Figure 9.	PMOD 1	14
Figure 10.	PMOD 2	15
Figure 11.	PMOD 3	15
Figure 12.	PMOD 4	16
Figure 13.	PMOD 5	17
Figure 14.	PMOD 6	17
Figure 15.	Power and User LEDs	18
Figure 16.	S2 + S3 User Switches	18
Figure 17.	Reset and User Switches	19
Figure 18.	Ethernet Connector	20
Figure 19.	MEMS MICs	21
Figure 20.	CAN Connector	21
Figure 21.	Camera Module	22

Tables

Table 1.	Default Jumper Settings	9
Table 2.	Debug USB Connector (J10)	11
Table 3.	JTAG/SWD Connector (J12)	12
Table 4.	USB Full Speed Connector (J11)	13
Table 5.	PMOD 1 Connector (J7)	14
Table 6.	PMOD 2 Connector (J4)	14
Table 7.	PMOD 3 Connector (J1)	15
Table 8.	PMOD 4 Connector (J2)	16
Table 9.	PMOD 5 Connector (J5)	16
Table 10.	PMOD 6 Connector (J8)	17
Table 11.	AIK-RA6M3 LED Functions	18

Table 12. AIK-RA6M3 Switches	18
Table 13. Ethernet Port Assignments	20
Table 14. Ethernet Components	20
Table 15. MICs Port Assignments	20
Table 16. CAN Port Assignments	21
Table 17. Camera Module Socket	21
Table 18. AIK-RA6M3 Design Package Contents	23

1. Kit Overview

The AIK-RA6M3 enables developers to get started with initial firmware development. For more information on the AIK-RA6M3, see www.renesas.com/AIK-RA6M3.

The kit includes breakout pin headers for direct access to the RA6M3 microcontroller I/O pins. On-board support is included for several of the most commonly used peripherals, as well as interfaces for several common ecosystem standards.

- Renesas RA6M3 Microcontroller Group
 - R7FA6M3AH3CFC
 - 176-pin LQFP package
 - 120 MHz Arm® Cortex® M4 core with FPU
 - 640 KB on-chip SRAM
 - 2 MB on-chip code flash memory
 - 64 KB on-chip data flash memory
- Connectivity
 - One USB micro AB full speed connector for the Main MCU
 - SEGGER J-Link® On-board (OB) interface for debugging and programming of the RA6M3 MCU. A 10 pin JTAG/SWD interface are also provided for connecting optional external debuggers and programmers.
 - Six PMOD connectors, allowing use of appropriate PMOD compliant peripheral plug-in modules for rapid prototyping
 - One Auxiliary Port connector
 - One CAN interface
 - One RJ-45 RMII Ethernet interface
- Multiple clock sources
 - Main MCU oscillator crystals, providing precision 24.000 MHz and 32,768 Hz reference clocks
 - Additional low-precision clocks are available internal to the Main MCU
- MCU reset push button switch
- Two user push button switches, monitored by Main MCU firmware
- One Dip switch
- Operating voltage
 - External 5 V input through any of the USB connections
- A Blue LED indicating availability of regulated power
- One LED RGB , controlled by the Main MCU firmware
- MCU boot configuration jumper

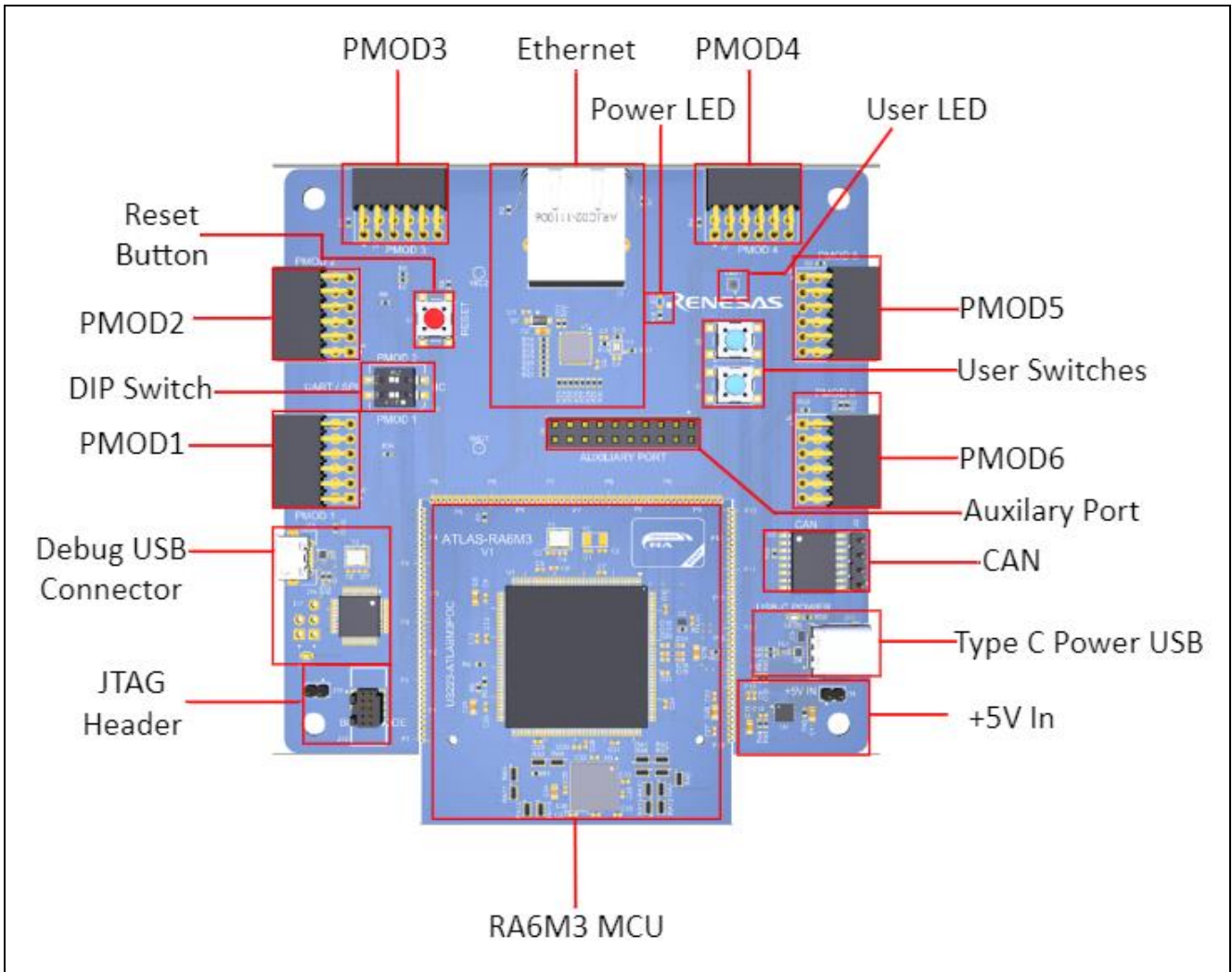

Figure 1. AIK-RA6M3 Top Side

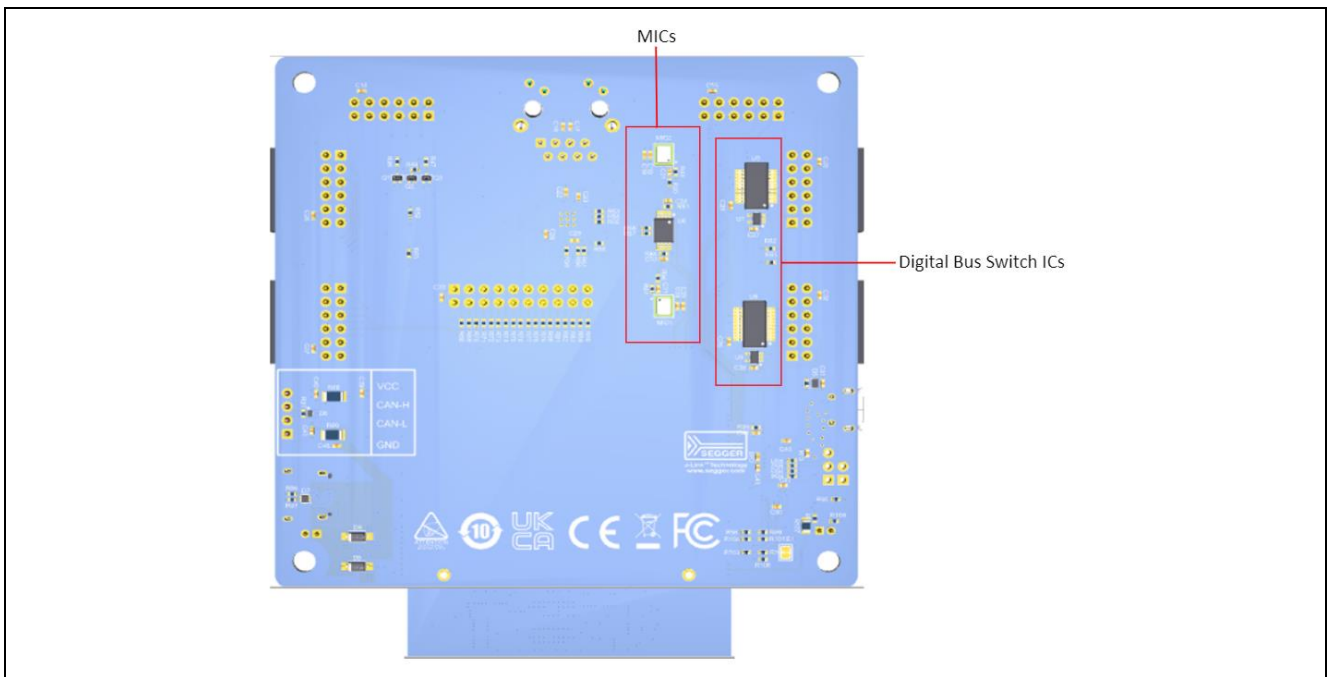

Figure 2. AIK-RA6M3 Bottom Side

1.1 Assumptions and Advisory Notes

1. Tool readiness: This document assumes that the Flexible Software Package, J-Link drivers and development tools are installed on the Windows® PC.
2. Tool experience: You have prior experience working with embedded development environments such as the e2 studio Integrated Solutions Development Environment (ISDE). You have familiarity working with common terminal emulation program (such as Tera Term).
3. Subject knowledge: You have basic knowledge about the Flexible Software Package and USB device stack and its communication protocols.
4. Note: It is recommended that you first refer to the Quick Start Guide of your Kit to become acquainted with the hardware.

2. Kit Contents

The following components are included in the Development Kit S7G2 (AIK-RA6M3):

1. AIK-RA6M3 board.
2. OV2640 Camera module
3. Renesas ICM-42670-P PMOD Board
4. Display
5. Ethernet patch cable
6. Micro USB device cable (type-A male to micro-B male)
7. Micro USB device cable (type-A male to type-C male)

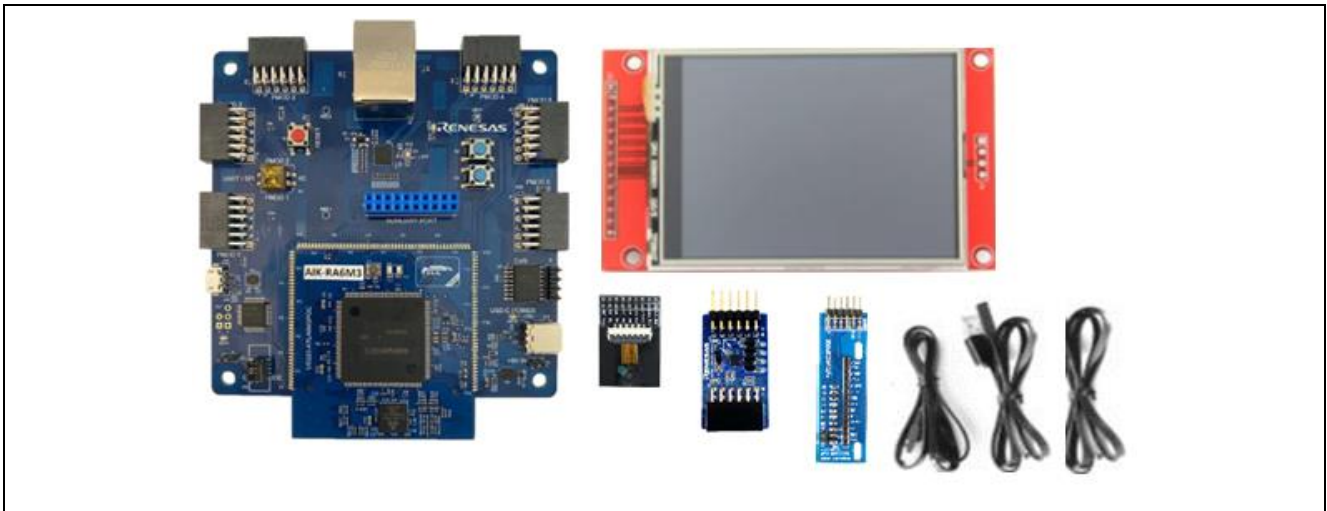

Figure 3. Kit Contents

3. Ordering Information

AIK-RA6M3 Orderable Part Number: RTK0EG0001D00001BE

4. Getting Started with Embedded Software Development Using the AIK-RA6M3

To develop and execute embedded applications for RA microcontrollers, Flexible Software Package (FSP) and development tools are required to be installed on your computer.

4.1 Installing the Flexible Software Package and Development Tools

The FSP, J-Link USB drivers and the supported development tool chains are bundled and available as single downloadable platform installer.

Visit the FSP webpage (www.renesas.com/ra/fsp) and scroll down to the Release section. Download the platform installer from the link provided there.

e² studio Platform Installer: Installs the Flexible Software Package and Eclipse-based e² studio for the RA integrated development environment (IDE) with GCC ARM embedded compiler and J-Link USB drivers. The e² studio package is also available at www.renesas.com/ra/e2studio.

4.1.1 Useful Tips

Renesas recommends new users use the “Quick Install” option provided in the installation wizard, to minimize the amount of manual configuration needed. You can always come back and install additional options later.

The platform installer includes the Flexible Software Package as well as the selected development tool. There is no need to install these packages separately.

4.1.2 Quick Setup Guide for RA MCUs

Renesas provides several example projects to demonstrate different capabilities of the AIK RA MCUs. These example projects are a good starting point for you to develop your custom applications. Example projects available for the RA boards are listed at <https://github.com/renesas/aiot-ready>.

The RA boards are pre-programmed with a quick start example project (Asset Movement Detection) that runs when the board is powered on with Renesas ICM-42670-P PMOD Board in PMOD1 and SW1.1 switched to IIC.

5. Hardware Details

5.1 Kit Architecture

AIK-RA6M3 have two functional areas:

MCU section (Daughterboard)

Peripherals section (Motherboard)

The MCU section includes the MCU, Clocks, SDRAM.

The Peripherals section includes Power Delivery, User LEDs and Pushbutton Switches, Debug Interface, USB Full Speed, PMOD, Ethernet, CAN and Camera Module peripheral groups.

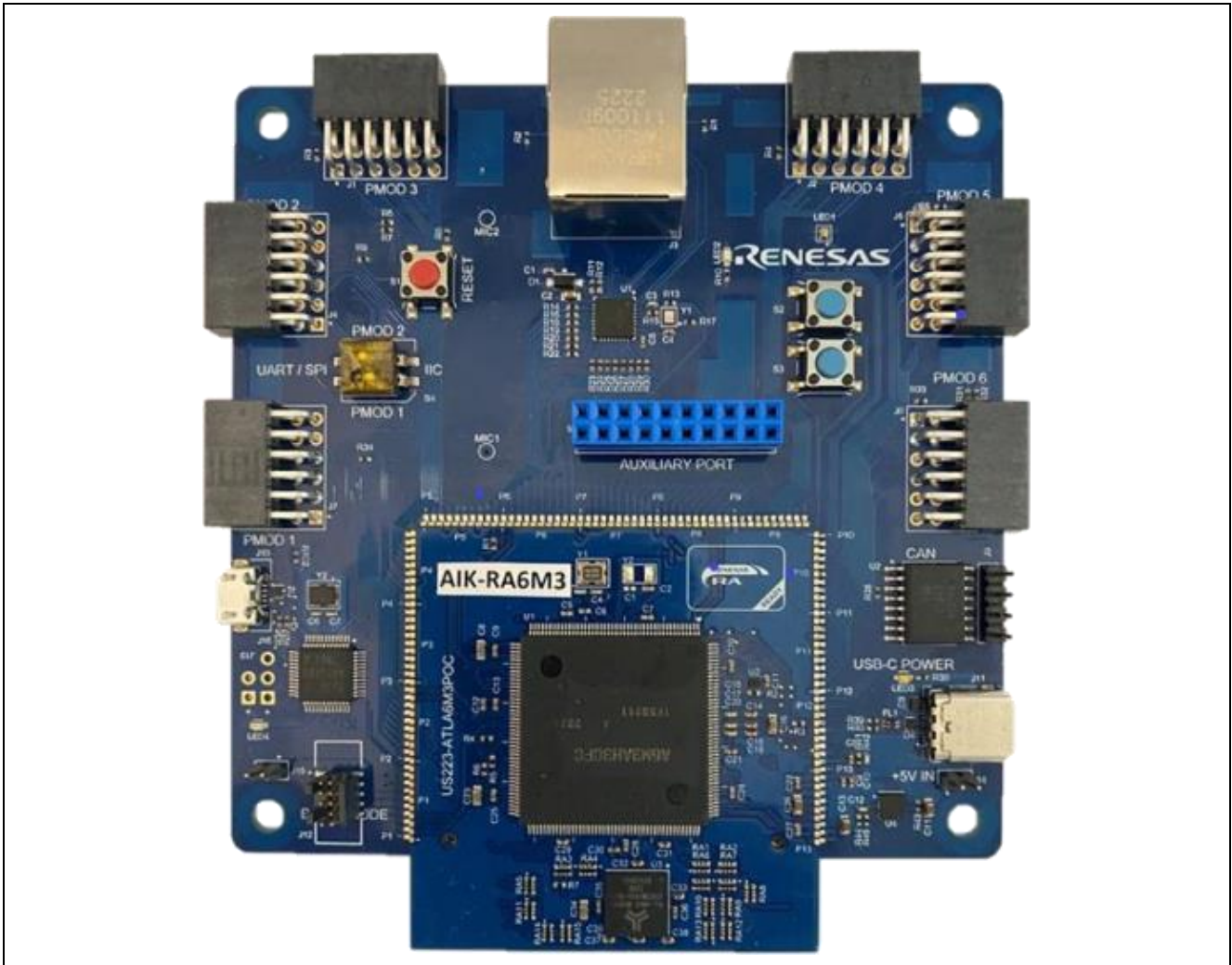

Figure 4. AIK- RA6M3 Board

5.1.1 System Block Diagram

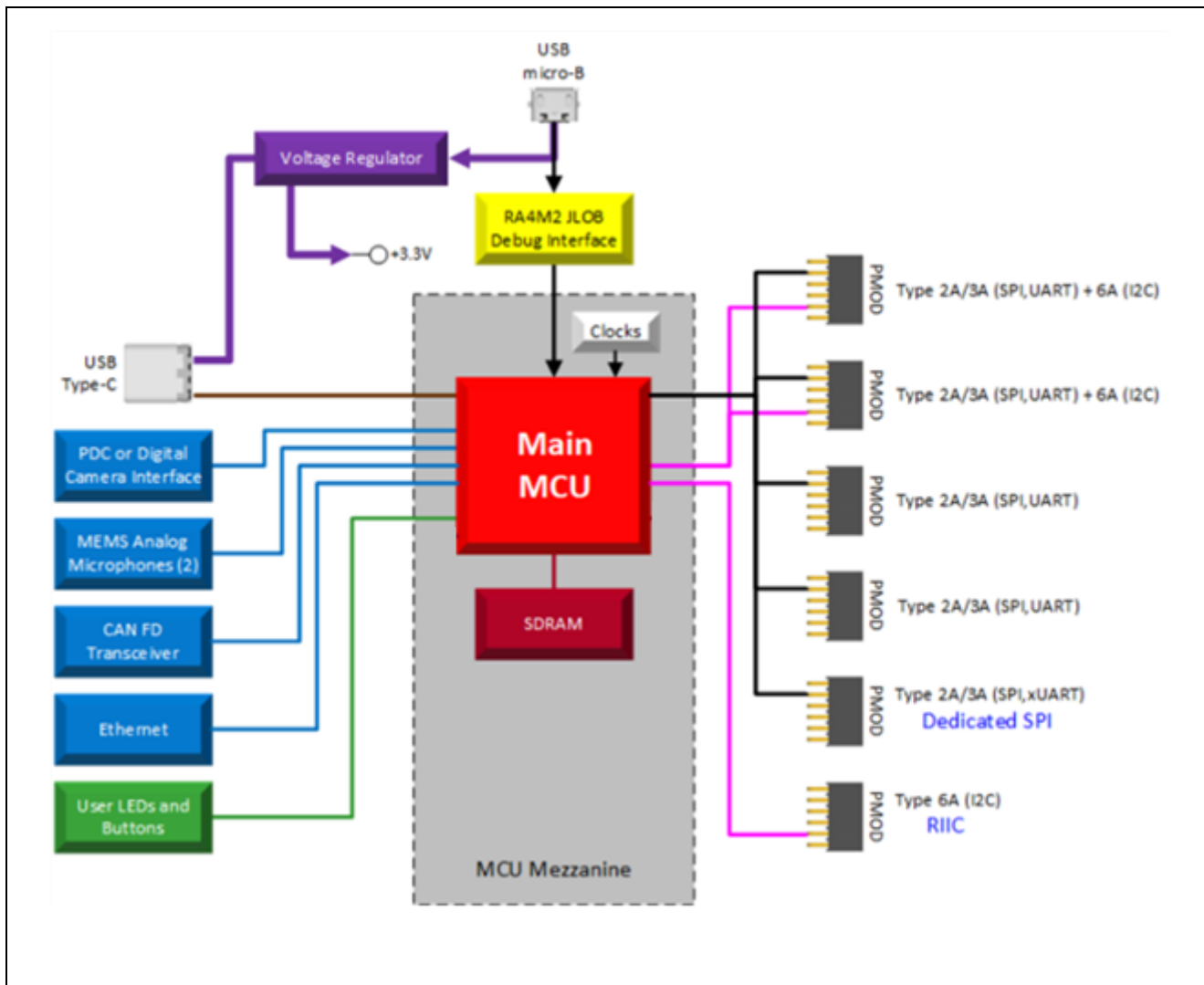

Figure 5. AIK-RA6M3 Block Diagram

5.2 General Features

5.2.1 Jumper Settings

5.2.1.1 Default Board Configuration

The following table describes the default settings for each jumper on the AIK-RA6M3.

The Circuit Group for each jumper is the designation found in the board schematic.

Table 1. Default Jumper Settings

Location	Circuit Group	Default Open/Closed	Function
J15	BOOT MODE	Open	Configures the MCU for normal boot mode

5.2.2 Power Requirements

AIK-RA6M3 is designed for +5V operation. An on-board Low Dropout Regulator (LDO) is used to convert the 5V supply to 3.3V, which is then used to power the main MCU and many of the peripheral features of the AIK-RA6M3.

5.2.2.1 Power Supply Options

AIK-RA6M3 can be powered in three different ways as described in this section.

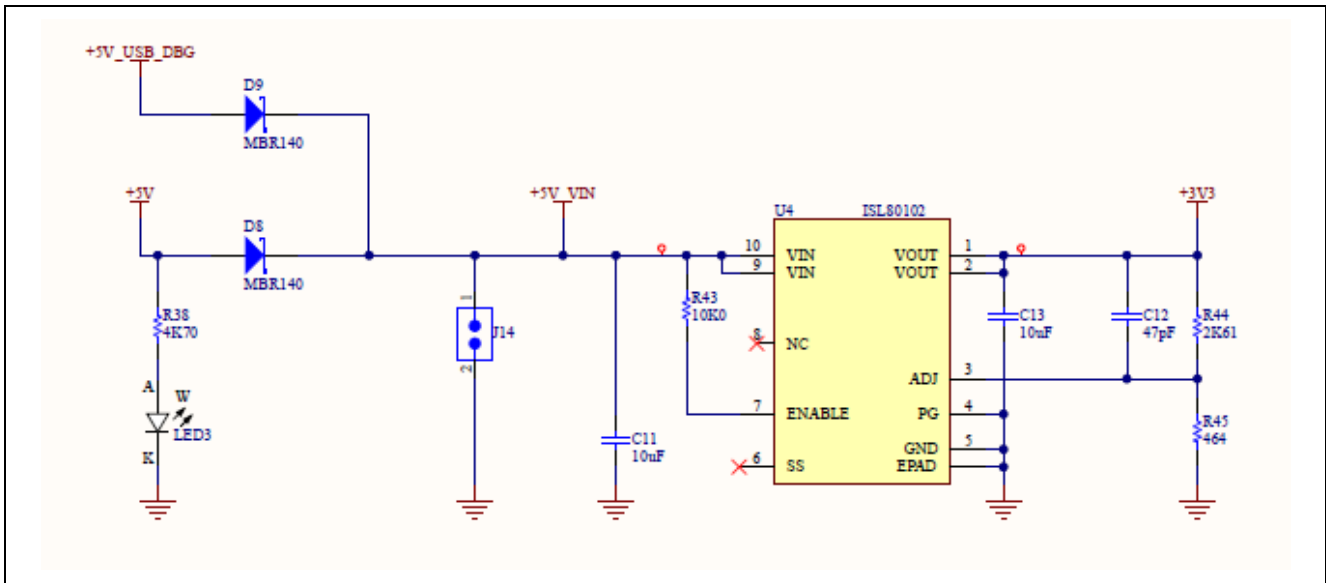

Figure 6. Power Supply Options

5.2.2.2 Option 1: Debug USB

5V may be supplied from an external USB host to the USB Debug connector (J10). Power from this source is connected to the Main System 5V Power. Reverse current protection is provided between this connector and the Main System 5V Power.

5.2.2.3 Option 2: USB C Full Speed

5V may be supplied from an external USB host to the USB C connector (J11) labelled USB C on the board. Power from this source is connected the Main System 5V Power. Reverse current protection is provided between this connector and the Main System 5V Power.

5.2.2.4 Option 3: External Power Supply

5V may be supplied from an external header (J14)

5.2.2.5 Power-up Behavior

When powered, the blue LED2 will light up. See the AIK-RA6M3 Getting Started Guide for further information on initial power up behavior.

5.2.3 MCU Boot Mode

A two-pin header (J15) is provided to select the Boot Mode of the MCU. For normal operation, or Single-Chip Mode, leave J15 open. To enter SCI Boot Mode or USB Boot Mode, place a jumper on J15.

5.2.4 Debug Interface

The AIK-RA6M3 Debug Interface has two operating modes: (1) Onboard Debug using the Renesas RA4M2 microcontroller J-Link On-Board, 2) External Debug using the JTAG connector(J12).

The J-Link OB USB Micro-B connection jack (J10) connects the Renesas RA4M2 J-Link MCU to an external USB Full Speed Host, allowing re-programming and debugging of the Main MCU firmware. This is the default debug mode for AIK-RA6M3.

The Renesas RA4M2 J-Link MCU connects to the Main MCU using the SWD interface.

Table 2. Debug USB Connector (J10)

Debug USB Connector		AIK-RA6M3
Pin	Description	Signal/Bus
1	+5VDC	+5V_JUSB
2	Data-	U3 USB_DM (U3-14)
3	Data+	U3 USB_DP (U3-15)
4	USB ID, jack internal switch, cable inserted	N.C.
5	Ground	GND

A yellow indicator LED4 provides a visual status of the state of the debug interface. When AIK-RA6M3 is powered on, and LED4 is blinking, this indicates that the RA4M2 J-Link OB is not connected to a programming host. When LED4 is on solid, this indicates that the RA4M2 J-Link OB is connected to a programming interface.

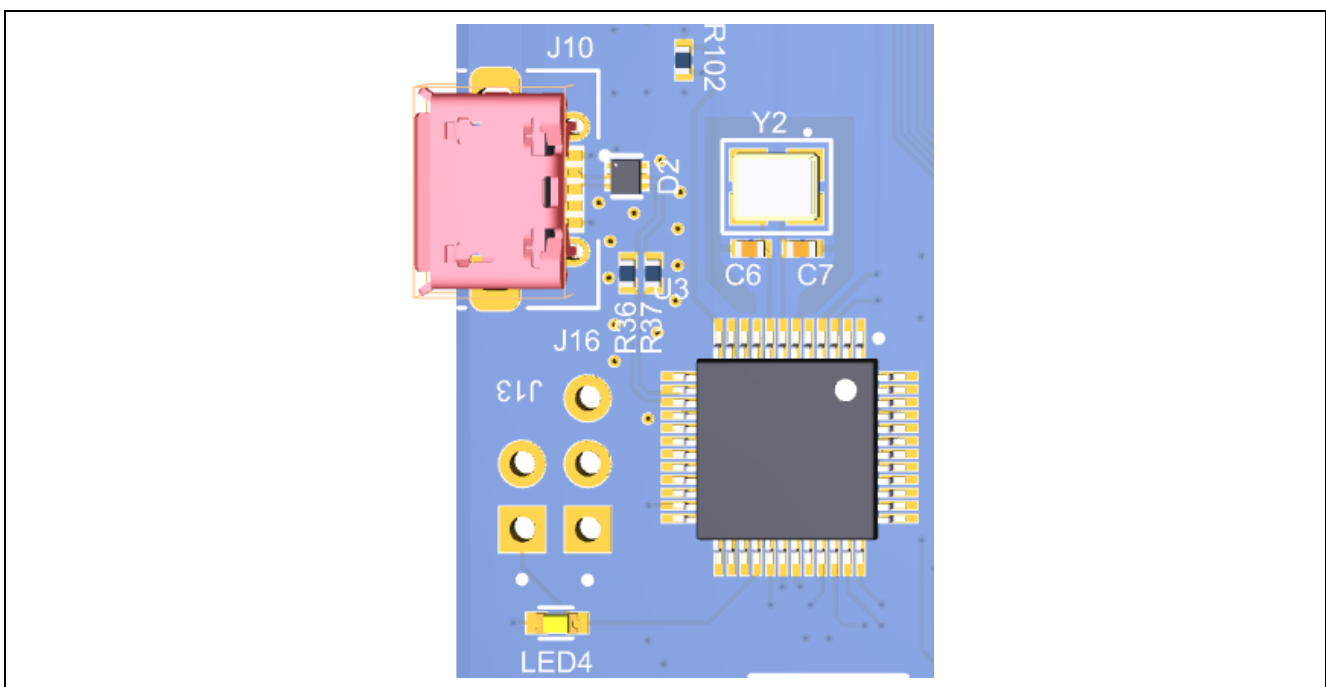

Figure 7. AIK-RA6M3 Debug Interface

5.2.4.1 External Debug

One 10-pin Cortex® Debug Connector is provided at J12, which supports JTAG and SWD. This connector may be used for external debug of the Main MCU.

Table 3. JTAG/SWD Connector (J12)

JTAG Connector			AIK-RA6M3
Pin	JTAG Pin Name	SWD Pin Name	Signal/Bus
1	VTref	VTref	+3V3
2	TMS	SWDIO	P101/ (U3-35)
3	GND	GND	GND
4	TCK	SWCLK	P102/ (U3-34)
5	GND	GND	GND
6	TDO	SWO	P100/ (U3-36)
7	Key	Key	N.C.
8	TDI	NC/EXTb	P103/ (U3-33)
9	GNDDetect	GNDDetect	GND (cut E1 to open)
10	RESET	RESET	P112 (U3-29)

The Cortex® Debug Connector is fully described in the Arm® CoreSight™ Architecture Specification.

5.2.4.2 Debug Out using Renesas RA4M2 J-Link OB

The AIK-RA6M3 Debug Interface can be configured to use the Renesas RA4M2 to debug a RA6M3 device on an external board.

A yellow indicator LED4 provides a visual status of the state of the debug interface. When AIK-RA6M3 is powered on, and LED4 is blinking, this indicates that the Renesas RA4M2 debugger is not connected to a programming host. When LED4 is on solid, this indicates that the Renesas RA4M2 is connected to a programming interface.

5.2.5 USB Full Speed

The USB C connection jack (J11) connects the Main MCU USB Full Speed interface to an external USB interface, allowing communications for testing and use of the Main MCU firmware. This connection can be configured as either a USB Device or a USB Host interface.

For a USB Device configuration, set Jumper J14 to pins 1-2, and configure the Main MCU firmware to use the USB Full Speed ports in device mode. Power from an external USB Host on this connection can be used to provide power to AIK-RA6M3.

Table 4. USB Full Speed Connector (J11)

USB Full Speed Connector		AIK-RA6M3
Pin	Description	Signal/Bus
A1	Ground	GND
A2	TX1+	N/A
A3	TX1-	N/A
A4	+5VDC	USB_VBUS 5V
A5	Configuration Detection (CC1)	CC1
A6	Data+	USB_DP
A7	Data-	USB_DM
A8	Configuration Detection (SBU1)	N/A
A9	+5VDC	N/A
A10	RX2-	N/A
A11	RX2+	USB_VBUS 5V
A12	Ground	GND
B1	Ground	GND
B2	TX2+	N/A
B3	TX2-	N/A
B4	+5VDC	USB_VBUS 5V
B5	Configuration Detection (CC2)	D7-3
B6	Data+	USB_DP
B7	Data-	USB_DM
B8	Configuration Detection (SBU)	N/A
B9	+5VDC	USB_VBUS 5V
B10	RX1-	N/A
B11	RX1+	N/A
B12	Ground	GND

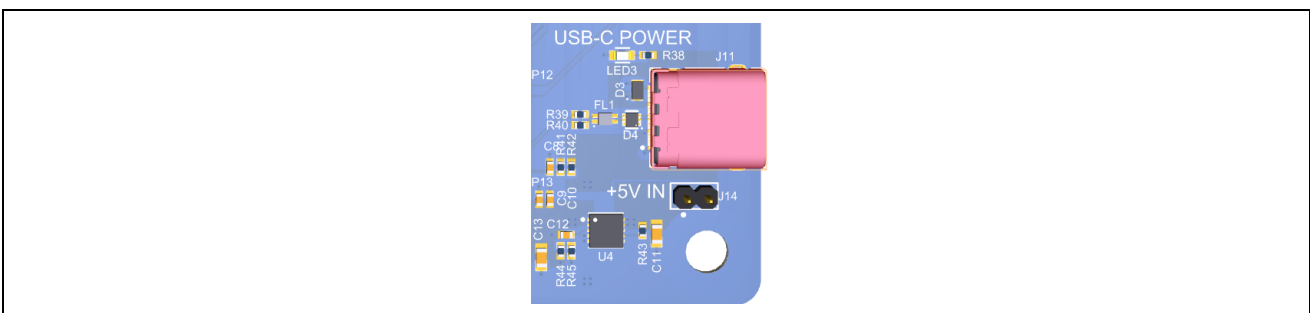

Figure 8. USB Full Speed Connector

5.2.6 PMOD 1

A 12-pin PMOD Type-2A connector is provided at PMOD 1. The Main MCU can act as the UART/SPI master, and the connected module acts as an UART/SPI slave device. The Main MCU can be used also as

IIC when changing SW4.1 DIP switch to IIC. This interface may additionally be re-configured in firmware as several other PMOD types.

This PMOD interface supports +3.3V devices. Please ensure that any PMOD device installed is compatible with a +3.3V supply.

Table 5. PMOD 1 Connector (J7)

PMOD 1 Connector AIK-RA6M3						
Pin	Description SPI	Signal/Bus SPI	Description UART	Signal/Bus UART	Description IIC	Signal/Bus IIC
1	SS	P207	CTS	P207	INT	P000
2	MOSI	P203	TXD	P203	RESET	P203
3	MISO	P202	RXD	P202	SCL	P205
4	SCK	P204	RTS	P204	SDA	P206
5	GND	VSS	GND	VSS	GND	VSS
6	VCC	+3.3V	VCC	+3.3V	VCC	+3.3V
7	GPIO3	P000	INT	P000	INT	P208
8	GPIO4	P209	RESET	P209	RESET	P209
9	GPIO1	P210	GPIO1	P210	CS2	P210
10	GPIO2	P313	GPIO2	P313	SC3	P313
11	GND	VSS	GND	VSS	GND	VSS
12	VCC	+3.3V	VCC	+3.3V	VCC	+3.3V

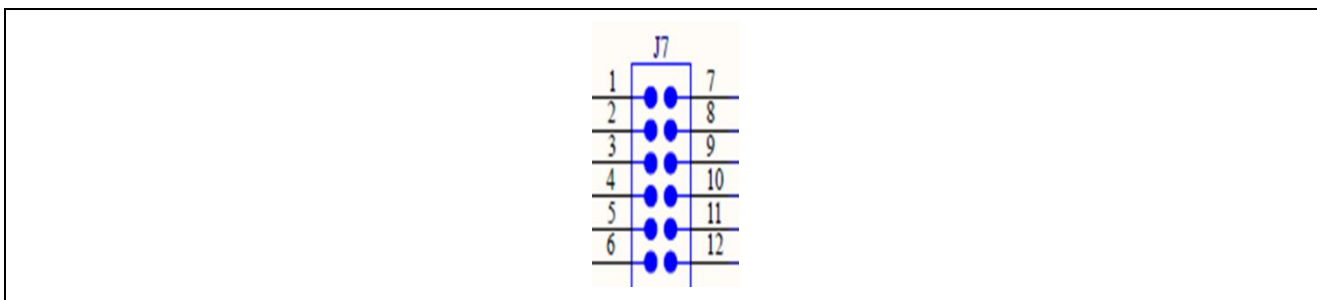

Figure 9. PMOD 1

5.2.7 PMOD 2

A 12-pin PMOD Type-2A connector is provided at PMOD 2. The Main MCU can act as the UART/SPI master, and the connected module acts as an UART/SPI slave device. The Main MCU can be used also as IIC when changing SW4 to IIC. This interface may additionally be re-configured in firmware as several other PMOD types.

This PMOD interface supports +3.3V devices. Please ensure that any PMOD device installed is compatible with a +3.3V supply.

Table 6. PMOD 2 Connector (J4)

PMOD 2 Connector AIK-RA6M3						
Pin	Description SPI	Signal/Bus SPI	Description UART	Signal/Bus UART	Description IIC	Signal/Bus IIC
1	SS	PB01	CTS	PB01	INT	P001
2	MOSI	P707	TXD	P707	RESET	P707
3	MISO	P706	RXD	P706	SCL	P205
4	SCK	PB00	RTS	PB00	SDA	P206
5	GND	VSS	GND	VSS	GND	VSS
6	VCC	+3.3V	VCC	+3.3V	VCC	+3.3V
7	GPIO3	P804	INT	P804	INT	P001
8	GPIO4	P414	RESET	P414	RESET	P314

9	GPIO1	P500	GPIO1	P500	CS2	P500
10	GPIO2	P507	GPIO2	P507	SC3	P507
11	GND	VSS	GND	VSS	GND	VSS
12	VCC	+3.3V	VCC	+3.3V	VCC	+3.3V

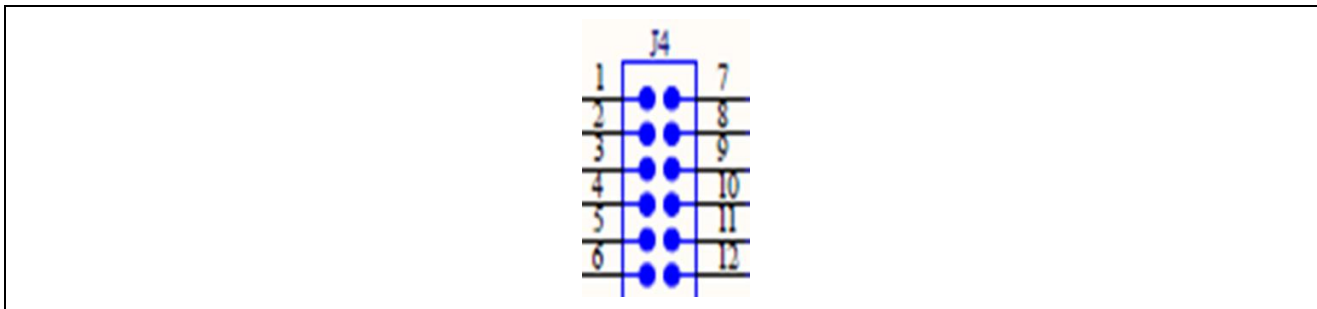

Figure 10. PMOD 2

5.2.8 PMOD 3

A 12-pin PMOD Type-2A connector is provided at PMOD 3. The Main MCU acts as the SPI master, and the connected module acts as an SPI slave device. This interface may additionally be re-configured in firmware as several other PMOD types.

This PMOD interface supports +3.3V devices. Please ensure that any PMOD device installed is compatible with a +3.3V supply.

Table 7. PMOD 3 Connector (J1)

PMOD 3 Connector		AIK-RA6M3
Pin	Description	Signal/Bus
1	SS/CTS_RTS	P606 (SS8/CTS8)
2	MOSI/TXD	PA00 (MOSI8/TXD8/SDA8)
3	MISO/RXD	P607 (MISO8/RXD8/SCL8)
4	SCK	PA01 (SCK8)
5	GND	VSS
6	VCC	+3.3V
7	INT (slave to master)	P002 (IRQ8-DS)
8	RESET (master to slave)	P508
9	GPIO1	P513
10	GPIO2	P600
11	GND	VSS
12	VCC	+3.3V

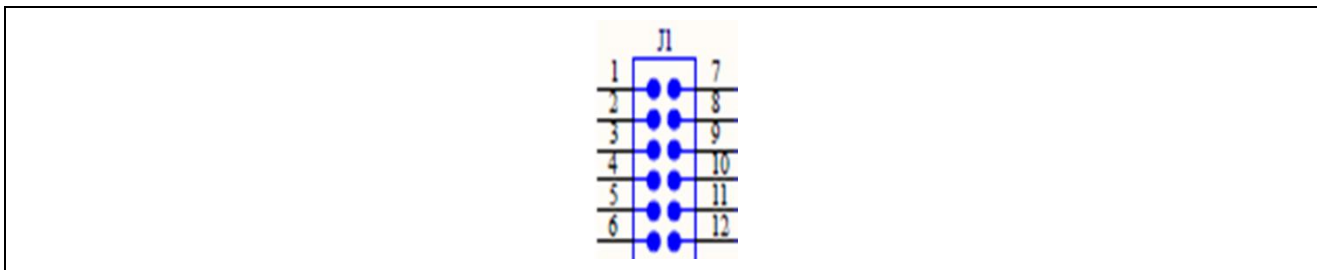

Figure 11. PMOD 3

5.2.9 PMOD 4

A 12-pin PMOD Type-2A connector is provided at PMOD 4. The Main MCU acts as the SPI master, and the connected module acts as an SPI slave device. This interface may additionally be re-configured in firmware as several other PMOD types.

This PMOD interface supports +3.3V devices. Please ensure that any PMOD device installed is compatible with a +3.3V supply.

Table 8. PMOD 4 Connector (J2)

PMOD 2 Connector		AIK-RA6M3
Pin	Description	Signal/Bus
1	SS/CTS_RTS	P504 (SS5/CTS5)
2	MOSI/TXD	P501 (MOSI5/TXD5)
3	MISO/RXD	P502 (MISO5/RXD5)
4	SCK	P503
5	GND	GND
6	VCC	+3.3V
7	INT (slave to master)	P004 (IRQ9)
8	RESET (master to slave)	P615
9	GPIO1	P802 (GPIO1)
10	GPIO2	P803 (GPIO2)
11	GND	GND
12	VCC	+3.3V

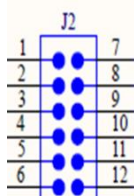

Figure 12. PMOD 4

5.2.10 PMOD 5

A 12-pin PMOD Type-2A connector is provided at PMOD 5. The Main MCU acts as the SPI master, and the connected module acts as an SPI slave device. This interface may additionally be re-configured in firmware as several other PMOD types.

This PMOD interface supports +3.3V devices. Please ensure that any PMOD device installed is compatible with a +3.3V supply.

Table 9. PMOD 5 Connector (J5)

PMOD 2 Connector		AIK-RA6M3
Pin	Description	Signal/Bus
1	SS/CTS_RTS	P806
2	MOSI/TXD	P900 (MOSI4/TXD4)
3	MISO/RXD	P315 (MISO4/RXD4)
4	SCK	P901
5	GND	GND
6	VCC	+3.3V
7	INT (slave to master)	NC
8	RESET (master to slave)	NC
9	Not Specified (GPIO)	NC
10	Not Specified (GPIO)	NC
11	GND	GND
12	VCC	+3.3V

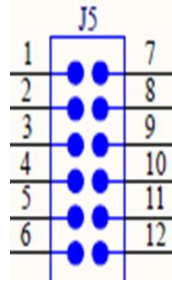

Figure 13. PMOD 5

5.2.11 PMOD 6

A 12-pin PMOD Type-2A connector is provided at PMOD 6. The Main MCU acts as the SPI master, and the connected module acts as an SPI slave device. This interface may additionally be re-configured in firmware as several other PMOD types.

This PMOD interface supports +3.3V devices. Please ensure that any PMOD device installed is compatible with a +3.3V supply.

Table 10. PMOD 6 Connector (J8)

PMOD 2 Connector		AIK-RA6M3
Pin	Description	Signal/Bus
1	INT (slave to master)	P006 (IRQ11)
2	RESET	P905
3	SCL	P400
4	SDA	P401
5	GND	GND
6	VCC	+3.3V
7	GPIO1	PA08
8	GPIO2	PA09
9	GPIO3	PA10
10	GPIO4	P805
11	GND	GND
12	VCC	+3.3V

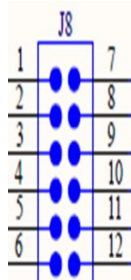

Figure 14. PMOD 6

5.2.12 LEDs

There are 5 LEDs provided on the AIK-RA6M3. In addition, the Ethernet connector has built-in link status and link speed LEDs.

The behavior of the LEDs on the AIK-RA6M3 is described in the following table.

Table 11. AIK-RA6M3 LED Functions

Designator	Color	Function	MCU Control Port
LED1	Blue	User LED	P908
LED1	Green	User LED	P907
LED1	Red	User LED	P906
LED2	Blue	Power on indicator	+3.3V
LED3	White	Power on indicator	+5V
LED4	Yellow	J-Link OB Status	J-Link OB MCU

The User LEDs may be isolated from the Main MCU, so the associated ports can be used for other purposes.

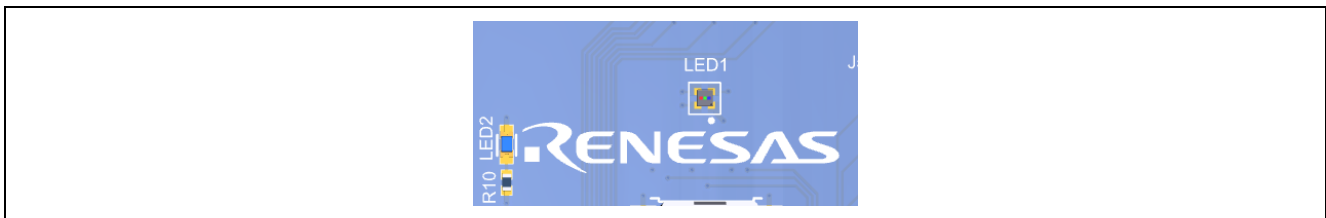

Figure 15. Power and User LEDs

5.2.13 Switches

Three miniature, momentary, mechanical push-button type SMT switches are mounted on AIK-RA6M3.

Pressing the Reset switch (S1) generates a reset signal to restart the Main MCU.

Table 12. AIK-RA6M3 Switches

Designator	Function	MCU Control Port	Button Color
S1	MCU Reset Switch	RESET#	Red
S2	User Switch	P007	Blue
S3	User Switch	P003	Blue
S2 + S3	And Gate	P005	
S4	UART/SPI – IIC DIP Switch		White x2

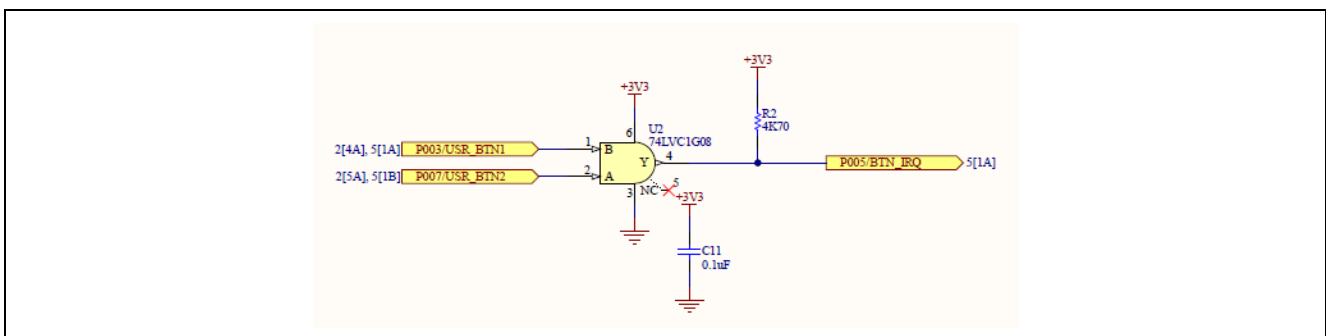

Figure 16. S2 + S3 User Switches

The User Switches S2 and S3 if pressed together can be used for interrupt operation

The DIP Switch S4 can be used to change between UART/SPI and IIC for PMOD 2

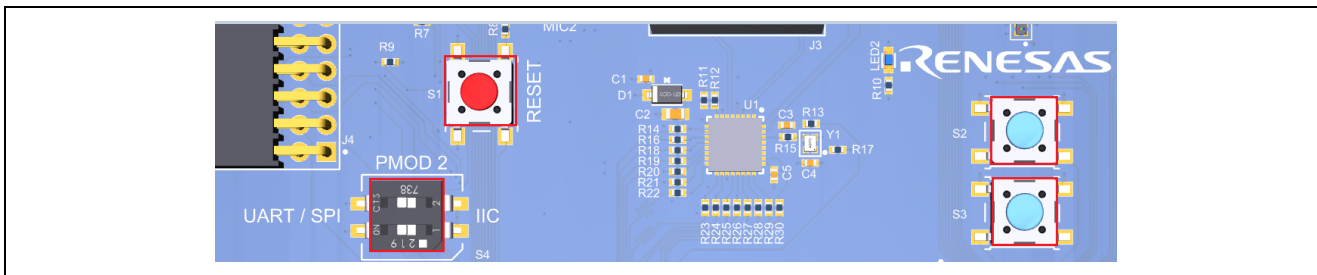

Figure 17. Reset and User Switches

5.3 Special Features Access

5.3.1 Ethernet

The Ethernet interface uses an RMII Ethernet Physical Layer Transceiver (PHY) (U1), connected to an RJ45 standard Ethernet connector (J3) with integrated magnetics and status indicators. The Ethernet clock is sourced from a precision 25 MHz clock crystal connected directly to the Ethernet PHY.

Table 13. Ethernet Port Assignments

Ethernet Signal Description	AIK-RA6M3 Port
RESET#	P010
MDC	P214
MDIO	P211
CRS_DV	P705
TXD_EN	P405
TXD0	P700
TXD1	P404
RXD1	P703
RXD0	P702
RX_ER	P704
REF50CK	P701

Table 14. Ethernet Components

Component	Manufacturer	Manufacturer Part Number
Ethernet PHY	Renesas	ICS1894-32
ARJC01 Connector	Abracon	ARJC01-111002AR
50 MHz Oscillator	Abracon	ASCO-50.000MHZ-EK-T3

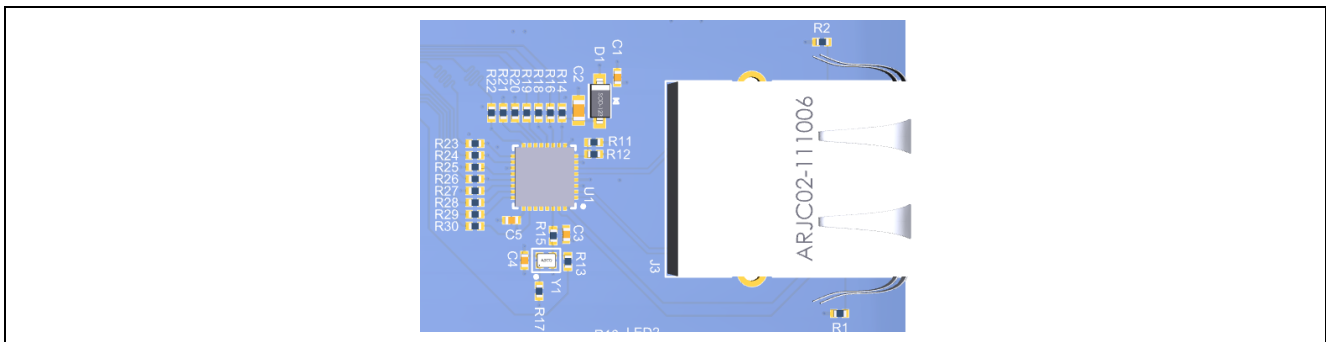

Figure 18. Ethernet Connector

5.3.2 MICS

AIK RA6M3 Includes two Analog Mems Microphones.

Table 15. MICs Port Assignments

Ethernet Signal Description	AIK-RA6M3 Port
MIC_AN1	P008
MIC_AN2	P009

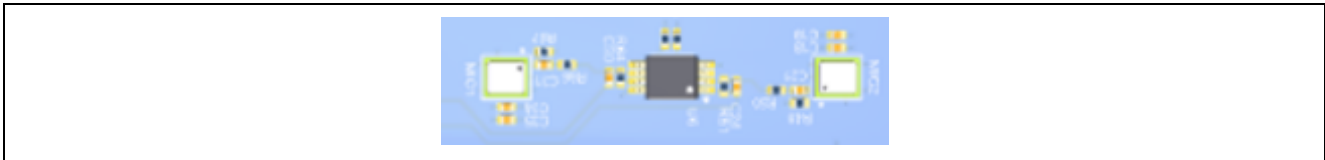

Figure 19. MEMS MICs

5.3.3 CAN/CAN-FD

At J9 we have the Controller Area Network bus interface (CAN).

Table 16. CAN Port Assignments

Pin	Description	Signal/Bus
1	VSS	+3.3V
2	CRX	P511
	CTX	P512
3	DE	P310
4	GND	GND

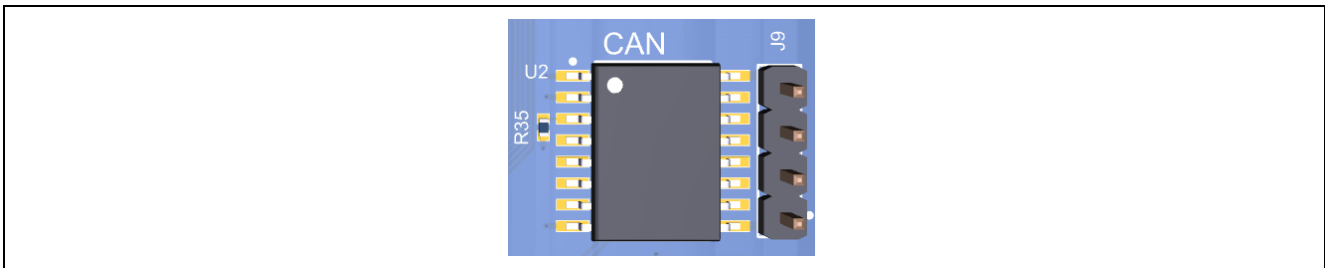

Figure 20. CAN Connector

5.3.4 Camera Module Socket

Near the center of the board A 20-pin connector is provided at J6 for the Camera Module Socket connector interface.

Table 17. Camera Module Socket

Camera Module Socket AIK-RA6M3		
Pin	Description	Signal/Bus
1	GND	GND
2	VCC	+3.3V
3	SCL	P400
4	SDA	P401
5	HSYNC	P409
6	VSYNC	P402
7	PCLK	P408
8	XCLK	P708
9	D7	P403
10	D6	P404
11	D5	P415

12	D4	P414
13	D3	P413
14	D2	P412
15	D1	P411
16	D0	P410
17	RET	P015
18	PWDN	P014
19	RET	P015
20	PWDN	P014

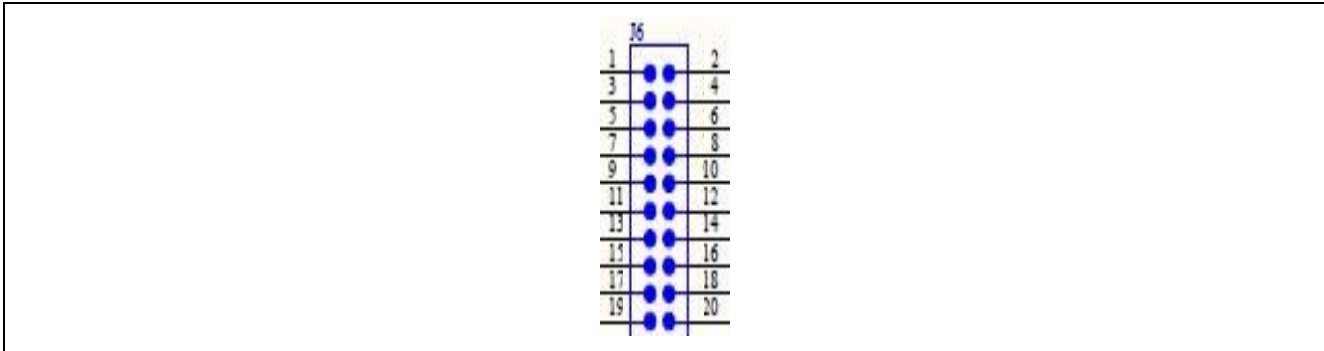

Figure 21. Camera Module

6. Certifications

6.1 EMC/EMI Standards

- FCC Notice (Class A)



This device complies with part 15 of the FCC Rules. Operation is subject to the following two conditions: (1) This device may not cause harmful interference, and (2) this device must accept any interference received, including interference that may cause undesired operation.

NOTE- This equipment has been tested and found to comply with the limits for a Class A digital device, pursuant to Part 15 of the FCC Rules. These limits are designed to provide reasonable protection against harmful interference in a residential installation. This equipment generates, uses and can radiate radio frequency energy and, if not installed and used in accordance with the instructions, may cause harmful interference to radio communications. However, there is no guarantee that interference will not occur in a particular installation. If this equipment does cause harmful interference to radio or television reception, which can be determined by turning the equipment off and on, the user is encouraged to try to correct the interference by one or more of the following measures:

- Reorient or relocate the receiving antenna.
- Increase the separation between the equipment and receiver.
- Connect the equipment into an outlet on a circuit different from that to which the receiver is connected.
- Consult the dealer or an experienced radio/television technician for help.

- Innovation, Science and Economic Development Canada ICES-003 Compliance:

CAN ICES-3 (A)/NMB-3(A)

- CE Class A (EMC)



This product is herewith confirmed to comply with the requirements set out in the Council Directives on the Approximation of the laws of the Member States relating to electromagnetic Compatibility Directive 2004/108/EEC.

Warning – This is a Class A product. In a domestic environment this product may cause radio interference in which case the user may be required to take adequate measures to correct this interference.

6.2 Material Selection, Waste, Recycling and Disposal Standards

- EU RoHS
- China SJ/T 113642014, 10-year environmental protection use period.

6.3 Safety Standards

- UL 94V-0

7. Design and Manufacturing Information

The design and manufacturing information for the EK-RA6M3 v1 kit is available in the “EK-RA6M3v1 Design Package” available on renesas.com/aik-ra6m3.

- Design package file name: aik-ra6m3-v1-designpackage.zip
- Design package contents

Table 18. AIK-RA6M3 Design Package Contents

Design Package Contents File Type	Content	File/Folder Name
-----------------------------------	---------	------------------

File (PDF)	Schematics	aik-ra6m3-v1-schematics
File (PDF)	Mechanical Drawing	aik-ra6m3-v1-mechdwg
File (PDF)	3D Drawing	aik-ra6m3-v1-3d
File (PDF)	BOM	aik-ra6m3-v1-bom
Folder	Manufacturing Files	Manufacturing Files
Folder	Design Files	Design Files-Altium

8. Website and Support

Visit the following URLs to learn about the kit and the RA family of microcontrollers, download tools and documentation, and get support.

AIK-RA6M3 Resources	www.renesas.com/aik-ra6m3
RA Product Information	www.renesas.com/ra
RA Product Support Forum	www.renesas.com/ra/forum
Renesas Support	www.renesas.com/support

Revision History

Rev.	Date	Description	
		Page	Summary
1.00	Oct.15.23	-	First release document

AIK-RA6M3 User's Manual

Publication Date: Oct.15.23

Published by: Renesas Electronics Corporation

AIK-RA6M3 v1 – User's Manual