

Type 2GT LoRa Module

Semtech LR1121 Chipset for LoRa

- Design Name: Type 2GT
- P/N: LBAA0XV2GT-001

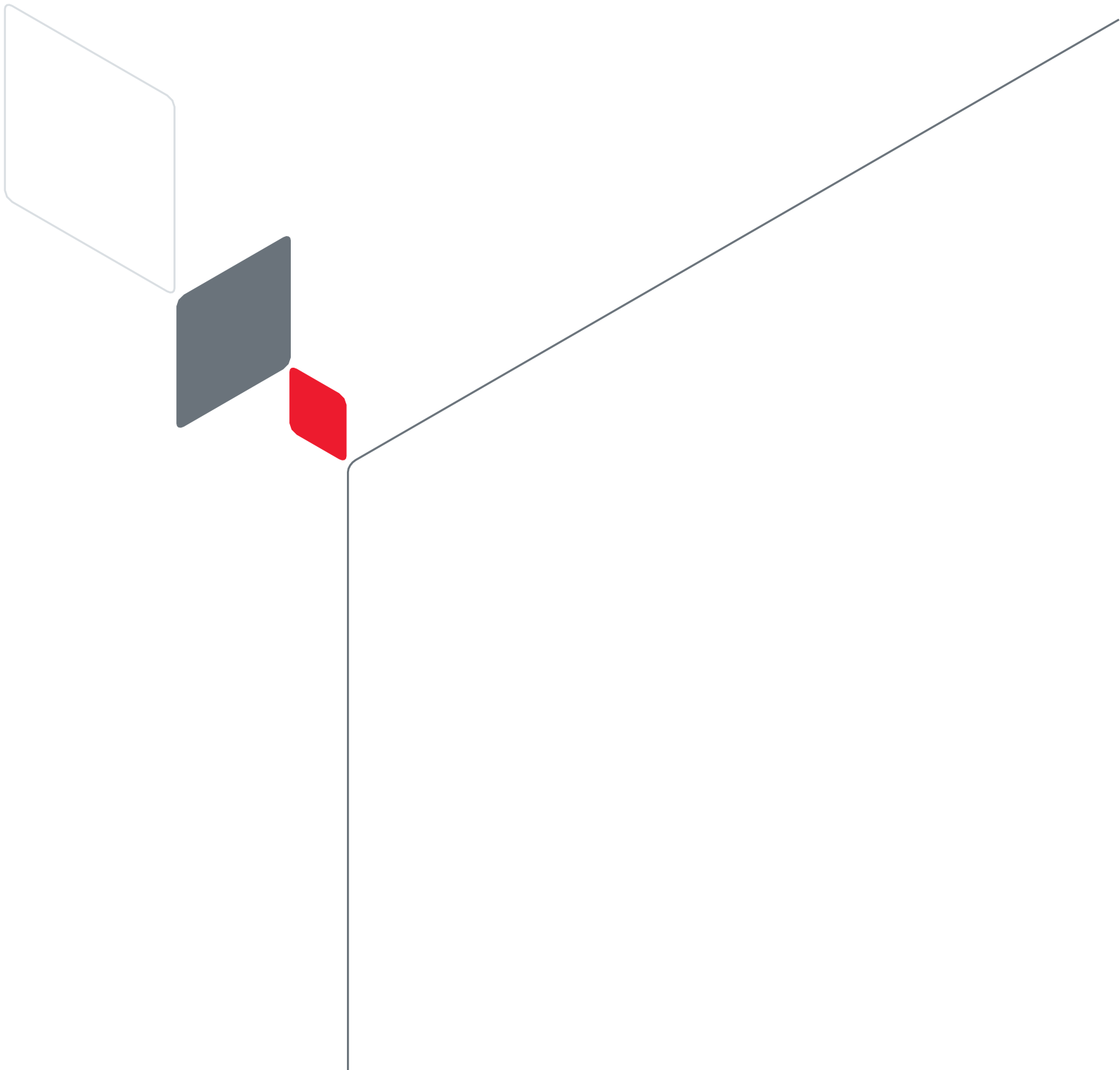

Table of Contents

1 Scope	5
2 Features & Benefits	5
2.1 Features.....	5
2.2 Benefits.....	5
3 Ordering Information	6
4 Block Diagram	7
5 Certification Information	8
5.1 Radio Certification.....	8
6 Dimensions, Markings and Terminal Configurations	9
7 Module Pin Descriptions	10
7.1 Pin Assignments	10
7.2 Pin Descriptions	11
8 Absolute Maximum Ratings	13
9 Operating Conditions	13
9.1 Operating Conditions	13
9.2 Digital I/O Requirements	13
9.3 Package Thermal Conditions	13
10 Power Sequence	13
10.1 Power-On Sequence.....	14
10.2 Power-Off Sequence.....	14
11 Host Interface Specification	15
11.1 SPI Specifications	15
12 DC/RF Characteristics	16
12.1 Sleep Current.....	16
12.2 DC/RF Characteristics for Sub-GHz.....	16
12.3 DC/RF Characteristics for S-band and 2.4G ISM band.....	17
13 Land Pattern	19
14 Reference Circuit	20
15 General Regulatory Certification for LBAA0XV2GT.....	21
15.1 Application Model Part Number.....	21
15.2 Label.....	21
15.3 Package Label	21
15.4 Country of Origin	22
16 Radio Regulatory Certification by Country for LBAA0XV2GT	22
16.1 JRL	22

16.2 FCC	22
16.3 ISED	22
16.4 CE.....	22
17 Tape and Reel Packing.....	23
17.1 Dimensions of Tape (Plastic Tape).....	23
17.2 Dimensions of Reel	24
17.3 Taping Diagrams.....	25
17.4 Leader and Tail Tape	26
17.5 Packaging (Humidity Proof Packing)	27
18 Notice	28
18.1 Storage Conditions.....	28
18.2 Handling Conditions	28
18.3 Standard PCB Design (Land Pattern and Dimensions)	28
18.4 Notice for Chip Placer	29
18.5 Soldering Conditions	29
18.6 Cleaning.....	29
18.7 Operational Environment Conditions	30
18.8 Input Power Capacity	30
19 Preconditions to Use Our Products	31
Revision History.....	33

Figures

Figure 1: Block Diagram	7
Figure 2: Dimensions, Markings, and Terminal Configurations	9
Figure 3: Pin Assignments (Top View)	10
Figure 4: Package Thermal Conditions	14
Figure 5: Land Patten	19
Figure 6: Reference Circuit	20
Figure 7: 2GT Module Label	21
Figure 8: Package Label Display	21
Figure 9: Dimensions of Tape (Plastic tape)	23
Figure 10: Dimensions of Reel (Unit: mm)	24
Figure 11: Taping Diagrams.....	25
Figure 12: Leader and Tail Tape.....	26
Figure 13: Peeling Force.....	26
Figure 14: Humidity Proof Packaging.....	27
Figure 15: Reflow soldering standard conditions (Example).....	29

Tables

Table 1: Document Conventions	4
Table 2: Ordering Information	6
Table 3: Markings	9
Table 4: Dimensions	9
Table 5: Terminal Configurations	11
Table 6: Pin Descriptions	11
Table 7: Absolute and Maximum Ratings.....	13
Table 8: Operating Conditions	13
Table 9: Digital I/O Characteristics.....	13
Table 10: SPI Timing Requirements	15
Table 11: Sleep and standby Specifications.....	16
Table 12: Sub-GHz Bands Receiver Specifications	16
Table 13: 2.4G ISM band Receiver Specifications	17
Table 14: Taping Specifications	25

About This Document

Murata's Type 2GT is a small and high-performance module based on Semtech LR1121 chipset, supporting LoRa. This datasheet describes Type 2GT module in detail.



Please be aware that an important notice concerning availability, standard warranty and use in critical applications of Murata products and disclaimers thereto appears at the end of this specification sheet.









Audience & Purpose

Intended audience includes any customer looking to integrate this module into their product, specifically RF, hardware, software, and systems engineers.

Document Conventions

Table 1 describes the document conventions.

Table 1: Document Conventions

Conventions	Description
	Warning Note Indicates very important note. Users are strongly recommended to review.
	Info Note Intended for informational purposes. Users should review.
	Menu Reference Indicates menu navigation instructions. Example: Insert → Tables → Quick Tables → Save Selection to Gallery 
	External Hyperlink This symbol indicates a hyperlink to an external document or website. Example: Embedded Artists AB  Click on the text to open the external link.
	Internal Hyperlink This symbol indicates a hyperlink within the document. Example: Scope  Click on the text to open the link.
<code>Console input/output or code snippet</code>	Console I/O or Code Snippet This text Style denotes console input/output or a code snippet.
<code># Console I/O comment // Code snippet comment</code>	Console I/O or Code Snippet Comment This text Style denotes a console input/output or code snippet comment. <ul style="list-style-type: none"> • Console I/O comment (preceded by "#") is for informational purposes only and does not denote actual console input/output. • Code Snippet comment (preceded by "//") may exist in the original code.

1 Scope

This specification applies to Geolocation module for LoRa.

2 Features & Benefits

2.1 Features

- ◆ SEMTECH LR1121 RF IC
 - LoRa Transceiver
- ◆ Low power consumption
- ◆ TCXO for maximum frequency accuracy
- ◆ Structure: Metal case + PCB (Lead Free Module)
- ◆ Weight: 0.32g
- ◆ MSL: MSL3
- ◆ LGA Surface-mount type
- ◆ RoHS compliant

Product name	LBAA0XV2GT-001
Technology	LoRa
Peripheral I/F	SPI, GPIOs
Dimensions	9.98 x 8.70 x 1.74 mm (max)
Operating Temperature	- 40 °C to 85 °C
Regulatory certification	FCC, ISED, JRL,CE

2.2 Benefits

- Allows simple RF design with minimum additional components required
- Simplifies PCB design as fewer layers are required on the final PCB
- The module's RF certification can be reused for end-product certification
- Quick time to market solution

3 Ordering Information

Table 2 shows the ordering information for Type 2GT module.

Table 2: Ordering Information

Ordering Part Number	Description
LBAA0XV2GT-001	Module order
LBAA0XV2GT-001SMP	Sample module order (If module samples are not available through distribution, contact Murata referencing this part number)
LBAA0XV2GT-001EVK	Type 2GT EVK

4 Block Diagram

The Type 2GT block diagram is presented in **Figure 1**.

Figure 1: Block Diagram

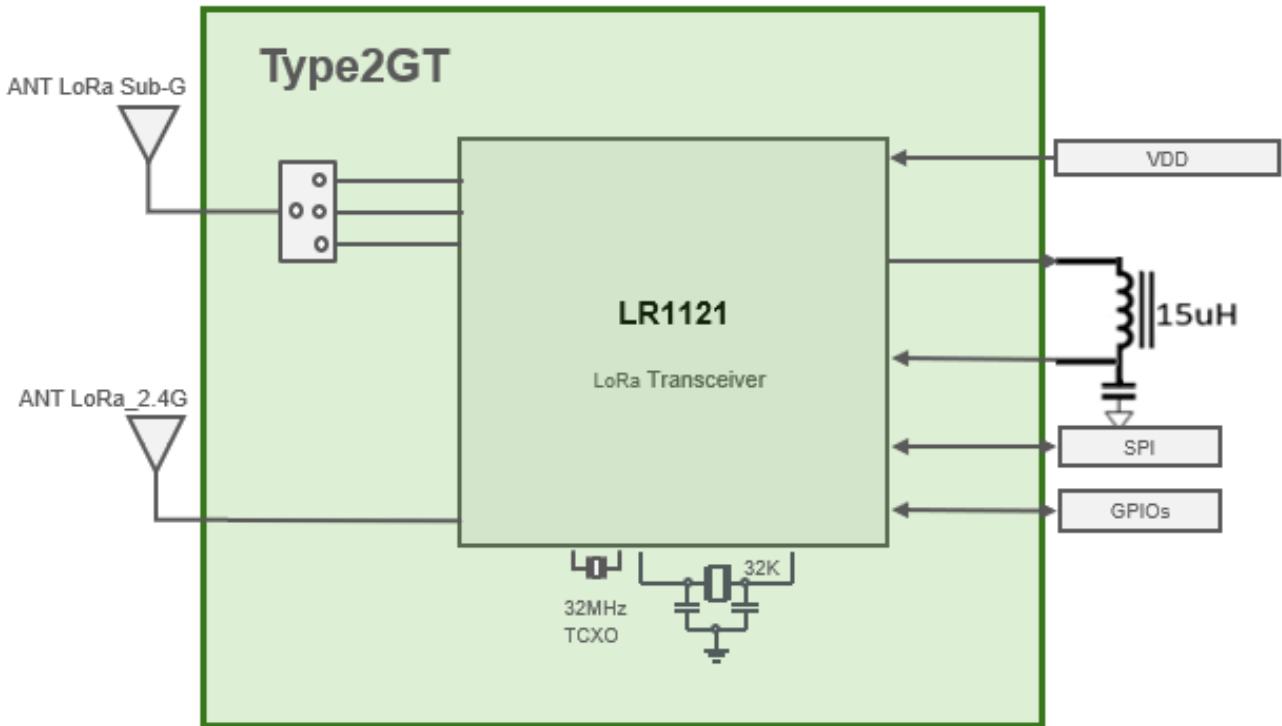

5 Certification Information

This section has information about radio certification.

5.1 Radio Certification

Target Countries	ID Number
US(FCC)	VPYLB2GT
Canada(ISED)	772C-LB2GT
Japan (JRL)	218-230222
Europe (CE)	Compliant with EN 300220-2 V3.2.1, EN 300440 V2.2.1, EN IEC 62311:2020

6 Dimensions, Markings and Terminal Configurations

This section has information on dimensions, marking, and terminal configurations for Type 2GT.

Figure 2: Dimensions, Markings, and Terminal Configurations

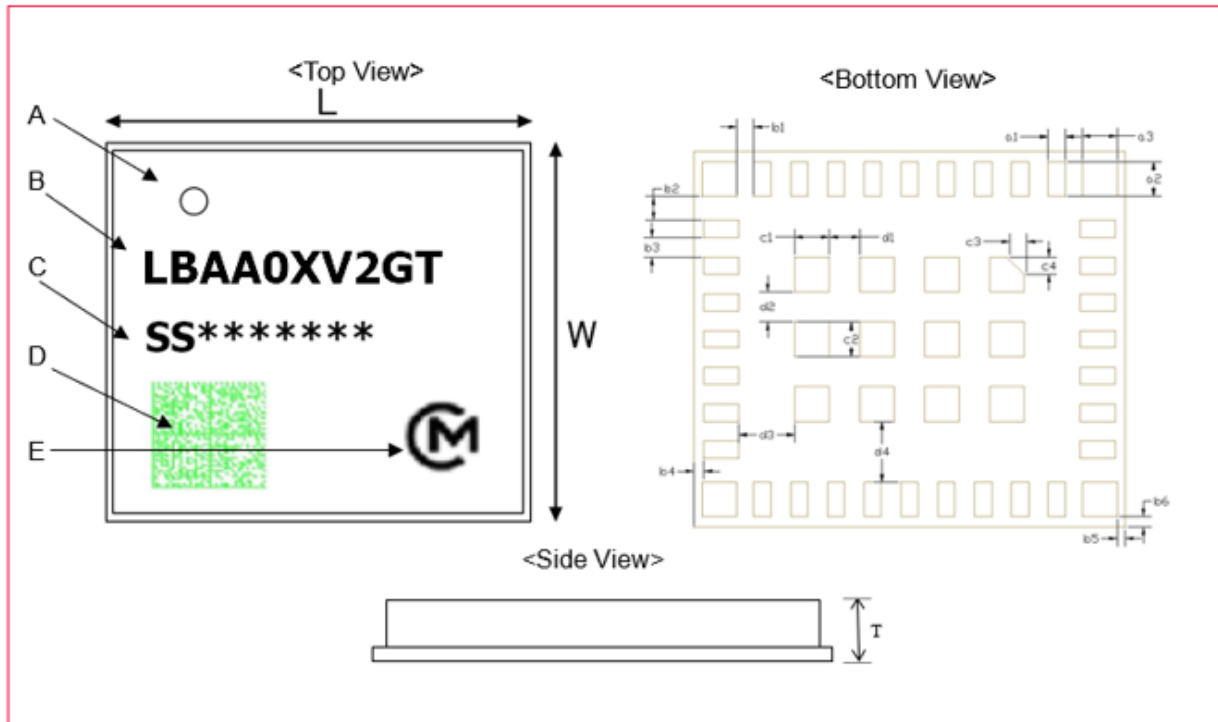

Table 3: Markings

Marking	Meaning
A	Pin 1 Marking
B	Module Type
C	Production Process Number
D	2D code
E	Murata Logo

Table 4: Dimensions

Mark	Dimensions (mm)	Mark	Dimensions (mm)	Mark	Dimensions (mm)	Mark	Dimensions (mm)
L	9.98 ± 0.1	W	8.7 ± 0.1	T	1.74 max	a1	0.4 ± 0.1
a2	0.8 ± 0.1	a3	0.8 ± 0.1	b1	0.4 ± 0.1	b2	0.55 ± 0.1
b3	0.45 ± 0.1	b4	0.24 ± 0.1	b5	0.19 ± 0.15	b6	0.25 ± 0.1
c1	0.8 ± 0.1	c2	0.8 ± 0.1	c3	0.4 ± 0.1	c4	0.4 ± 0.1
d1	0.7 ± 0.1	d2	0.7 ± 0.1	d3	1.3 ± 0.1	d4	1.4 ± 0.1

7 Module Pin Descriptions

This section has the Pin descriptions of Type 2GT and pin assignments layout descriptions.

7.1 Pin Assignments

The pin assignment layout (Top View) is shown in **Figure 3**.

Figure 3: Pin Assignments (Top View)

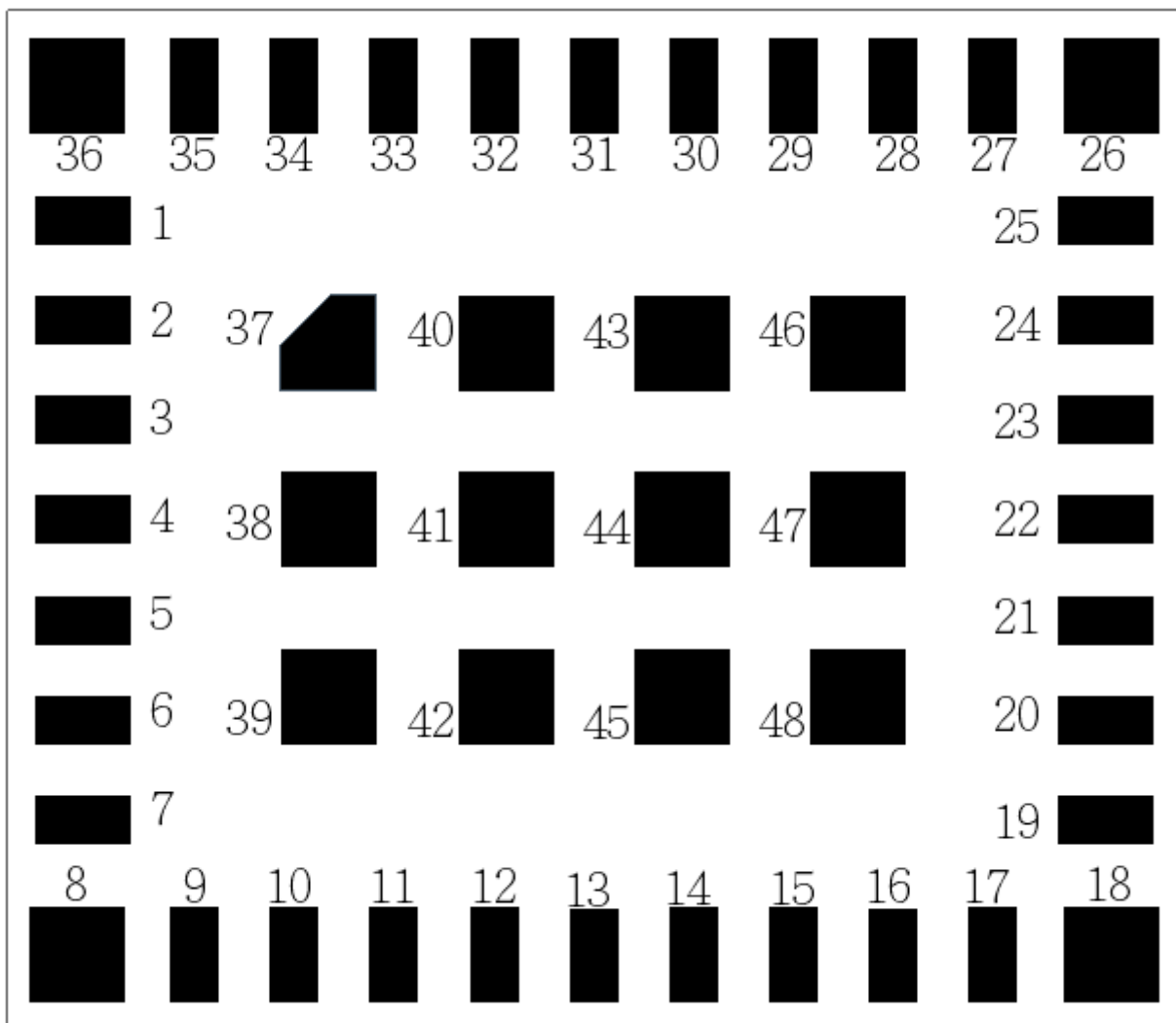

Table 5 illustrates the terminal configurations.

Table 5: Terminal Configurations

No.	Terminal Name	No.	Terminal Name	No.	Terminal Name
1	DIO9	17	NC	33	GND
2	DIO8	18	GND	34	GND
3	GND	19	ANT_LoRa_Sub_G	35	LR_NRST
4	VREG	20	GND	36	GND
5	GND	21	NC	37	GND
6	DCC_SW	22	GND	38-48	GND
7	GND	23	RFSW0		
8	GND	24	RFSW1		
9	LR_BUSY	25	RFSW2		
10	LR_NSS	26	GND		
11	LR_MISO	27	GND		
12	LR_MOSI	28	VDD		
13	LR_SCK	29	VDD		
14	GND	30	GND		
15	ANT_LoRa_2.4G	31	GND		
16	GND	32	GND		

7.2 Pin Descriptions

Table 6 describes Type 2GT Pins.

Table 6: Pin Descriptions

No.	Pin name	Type	Connection to IC Pin Name	Description
1	DIO9	I/O	LR1121:DIO9	Multi-purpose digital I/O
2	DIO8	I/O	LR1121:DIO8	Multi-purpose digital I/O
3	GND	GND	-	Ground
4	VREG	Power	LR1121: VREG	Regulated output voltage from the internal regulator LDO/ DC-DC
5	GND	GND	-	Ground
6	DCC_SW	Power	LR1121: DCC_SW	DC-DC Switcher Output
7	GND	GND	-	Ground
8	GND	GND	-	Ground
9	LR_BUSY	I/O	LR1121: DIO0/ BUSY	Used as “BUSY” indicator, indicating that the module cannot receive any commands from the host controller
10	LR_NSS	I/O	LR1121: DIO1	SPI NSS
11	LR_MISO	I/O	LR1121: DIO4	SPI MISO
12	LR_MOSI	I/O	LR1121: DIO3	SPI MOSI
13	LR_SCK	I/O	LR1121: DIO2	SPI SCK
14	GND	GND	-	Ground
15	ANT_LoRa_2.4G	RF	-	LoRa_2.4G RF port
16	GND	GND	-	Ground
17	NC	NC	-	-
18	GND	GND	-	Ground
19	ANT_LoRa_Sub_G	RF	-	LoRa_Sub_G RF port
20	GND	GND	-	Ground
21	NC	NC	-	-

No.	Pin name	Type	Connection to IC Pin Name	Description
22	GND	GND	-	Ground
23	RFSW0	I/O	LR1121: DIO5	Reserve for internal usage
24	RFSW1	I/O	LR1121: DIO6	Reserve for internal usage
25	RFSW2	I/O	LR1121: DIO7	Reserve for internal usage
26	GND	GND	-	Ground
27	GND	GND	-	Ground
28	VDD	Power	LR1121: VBAT,VBAT_RF	Power supply
29	VDD	Power	LR1121: VBAT,VBAT_RF	Power supply
30	GND	GND	-	Ground
31	GND	GND	-	Ground
32	GND	GND	-	Ground
33	GND	GND	-	Ground
34	GND	GND	-	Ground
35	LR_NRST	I	LR1121: NRESET	Module Reset
36	GND	GND	-	Ground
37	GND	GND	-	Ground
38-48	GND	GND	-	Ground

8 Absolute Maximum Ratings

The absolute maximum ratings are shown in **Table 7**.

Table 7: Absolute and Maximum Ratings

Parameter	Minimum	Maximum	Unit	
Storage Temperature	-40	+85	°C	
Supply Voltage	VDD	-0.3	3.6	V



Stresses in excess of the absolute ratings may cause permanent damage. Functional operation is not implied under these conditions. Exposure to absolute ratings for extended periods of time may adversely affect reliability. No damage assuming only one parameter is set at limit at a time with all other parameters are set within operating condition.

9 Operating Conditions

This section describes the operating conditions.

9.1 Operating Conditions

The operating conditions are shown in [Table 8](#).

Table 8: Operating Conditions

Parameter	Minimum	Typical	Maximum	Unit
Operating Temperature	-40		+85	°C
Operating Voltage	VDD	1.8	3.6	V



Operation beyond the recommended operating conditions is neither recommended nor guaranteed.

9.2 Digital I/O Requirements

[Table 9](#) shows the digital I/O characteristics of Type 2GT.

Table 9: Digital I/O Characteristics

Symbol	Parameter	Condition	Minimum	Typical	Maximum	Unit
V _{IH}	Input high voltage		0.7*VDD		VDD+0.3	V
V _{IL}	Input low voltage		-0.3		0.3* VDD	V
V _{OH}	Output high voltage	I _{max} = 2.5 mA	0.9*VDD		VDD	V
V _{OL}	Output low voltage	I _{max} = -2.5 mA	0		0.1* VDD	V

9.3 Package Thermal Conditions

The package thermal conditions are as below:

- $R\psi_{jt}$: N/A
- $R\psi_{jt} = N/A$



T_j : Junction temperature ($^{\circ}\text{C}$), T_t : Top temperature ($^{\circ}\text{C}$), P : Total Power Consumption (W)

Figure 4: Package Thermal Conditions

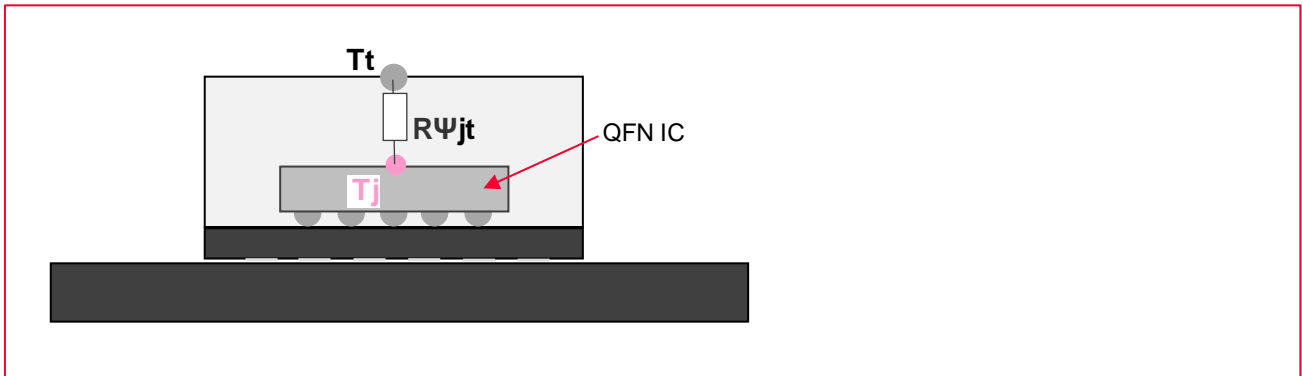

10 Power Sequence

10.1 Power-On Sequence

This section describes the power-on sequences along with their parameters.

There is no special demand on the VDD pins and other module pins.

10.2 Power-Off Sequence

This section describes the power-off sequences along with their parameters.

There is no special demand on the VDD pins and other module pins.

11 Host Interface Specification

11.1 SPI Specifications

The SPI interface gives access to the configuration register via a synchronous full-duplex protocol corresponding to CPOL = 0 and CPHA = 0 in Motorola/Freescale nomenclature. Only the slave side is implemented. A transfer is always started by a falling edge of NSS. MISO is high impedance when NSS is high. The SPI runs on the external SCK clock to allow high speed up to 16 MHz. All timings in following table are given for a max load cap of 10 pF.

Table 10: SPI Timing Requirements

Symbol	Description	Minimum	Typical	Maximum	Unit
t1	NSS falling edge to SCK setup time	31.25	-	-	ns
t2	SCK period	61.5	-	-	ns
t3	SCK high time	31.25	-	-	ns
t4	MOSI to SCK hold time	5	-	-	ns
t5	MOSI to SCK setup time	15	-	-	ns
t6	NSS falling to MISO delay	0	-	15	ns
t7	SCK falling to MISO delay	0	-	15	ns

12 DC/RF Characteristics

12.1 Sleep Current

Conditions: 25 °C, VDD = 3.3V

Table 11: Sleep and standby Specifications

Items	Condition	Contents			
		Minimum	Typical	Maximum	Unit
Current Consumption					
Sleep mode	8kB RAM retained		1.2		uA
Standby mode	HFXOSC ON, DC-DC		1.2		mA

12.2 DC/RF Characteristics for Sub-GHz

Conditions: 25 °C, VDD = 3.3V

Table 12: Sub-GHz Bands Receiver Specifications

Items	Condition	Contents			
		Minimum	Typical	Maximum	Unit
Current Consumption					
Supply current in receiver FSK mode	RxBoost OFF		6.4		mA
	RxBoost ON		8.5		mA
Supply current in receiver LoRa mode, RxBoost OFF	BW=125KHz, SF = 7		6.7		mA
	BW=125KHz, SF = 12		6.7		mA
	BW=250KHz, SF = 7		6.9		mA
	BW=250KHz, SF = 12		7		mA
	BW=500KHz, SF = 7		7.1		mA
	BW=500KHz, SF = 12		7.2		mA
Supply current in receiver LoRa mode, RxBoost ON	BW=125KHz, SF = 7		9.1		mA
	BW=125KHz, SF = 12		9		mA
	BW=250KHz, SF = 7		9.3		mA
	BW=250KHz, SF = 12		9.3		mA
	BW=500KHz, SF = 7		9.5		mA
	BW=500KHz, SF = 12		9.5		mA
Supply current in LoRa transmitter mode	LP PA 14dBm setting		28		mA
	HP PA 22dBm setting		120		mA
Tx Characteristics					
TX Output Power	LP PA 14dBm setting *1)	10.5	13.5	15.5	dBm
	HP PA 22dBm setting *2)	18	21	23	dBm
	LP PA Operating		0.5		dB

Items	Condition	Contents			
RF Output Power Stability vs Voltage Supply (1.8~3.6V)	HP PA Operating		6		dB
RF Output Power Stability vs Temperature (-40~+85°C)	LP PA Operating		1.3		dB
	HP PA Operating		1.3		dB
TX Power Range	Programmable in steps of -1dB from maximum TX power		31		steps
Rx Characteristics		Minimum	Typical	Typical	Unit
Sensitivity 2-FSK, RxBoost OFF	BRF = 4.8 kb/s, FDA = 5 kHz, BWF = 20 kHz		-117		dBm
Sensitivity 2-FSK, RxBoost ON	BRF = 4.8 kb/s, FDA = 5 kHz, BWF = 20 kHz		-118		dBm
Sensitivity LoRa, RxBoost OFF	BWL = 125 kHz, SF = 7		-125		dBm
	BWL = 125 kHz, SF = 12		-139		dBm
	BWL = 250 kHz, SF = 7		-122		dBm
	BWL = 250 kHz, SF = 12		-136		dBm
	BWL = 500 kHz, SF = 7		-118		dBm
	BWL = 500 kHz, SF = 12		-132		dBm
Sensitivity LoRa, RxBoost ON	BWL = 125 kHz, SF = 7		-127		dBm
	BWL = 125 kHz, SF = 12		-141		dBm
	BWL = 250 kHz, SF = 7		-124		dBm
	BWL = 250 kHz, SF = 12		-138		dBm
	BWL = 500 kHz, SF = 7		-120		dBm
	BWL = 500 kHz, SF = 12		-134		dBm

*1) tested with DutyCycle value=04, PAHASEL value =00

*2) tested with DutyCycle value=04, PAHASEL value =07

*3) The sensitivity in the 863.25MHz to 864.75MHz are not good as other channels. Customer needs to skip these frequency range (863.25MHz to 864.75MHz).

12.3 DC/RF Characteristics for 2.4G ISM band

Table 13: 2.4G ISM band Receiver Specifications

Items	Condition	Contents			
Current Consumption		Minimum	Typical	Maximum	Unit
Supply current in receiver FSK mode , RxBoost Off	4.8kb/s Sub-G band/2.4G band		6.9		mA
Supply current in receiver FSK mode , RxBoost On	4.8kb/s Sub-G band/2.4G band		7.7		mA
Supply current in receiver 2.4GHz LoRa mode, RxBoost Off	BW=406KHz, SF = 12		8.7		mA
	BW=812KHz, SF = 12		8		mA
Supply current in receiver 2.4GHz LoRa mode, RxBoost On	BW=406KHz, SF = 12		9.5		mA
	BW=812KHz, SF = 12		8.8		mA

Items	Condition	Contents			
Supply current in LoRa transmitter mode	+13dBm,HF PA		26		mA
Tx Characteristics		Minimum	Typical	Maximum	Unit
TX Output Power	+13dBm,HF PA		11.5		dBm
RF Output Power Stability vs Voltage Supply (1.8~3.6V)	+13dBm,HF PA		0.5		dB
TX Power Range	Programmable in steps of -1dB from maximum TX power		31		steps
Rx Characteristics *4)		Minimum	Typical	Typical	Unit
Sensitivity 2-FSK, RxBoost OFF	BRF = 4.8 kb/s, FDA = 5 kHz, BWF = 20 kHz		-112		dBm
Sensitivity in receiver 2.4GHz LoRa mode, RxBoost OFF	BW=406KHz, SF = 7		-115		dBm
	BW=812KHz, SF = 7		-112		dBm
Sensitivity in receiver 2.4GHz LoRa mode, RxBoost ON	BW=406KHz, SF = 12		-129		dBm
	BW=812KHz, SF = 12		-125		dBm

*4) The sensitivity from the 2431MHz to 2433MHz is not good as other channels. The sensitivity from the 2463MHz to 2465MHz is not good as other channels. Customer needs to skip these frequency range.

13 Land Pattern

Figure 5: Land Patten

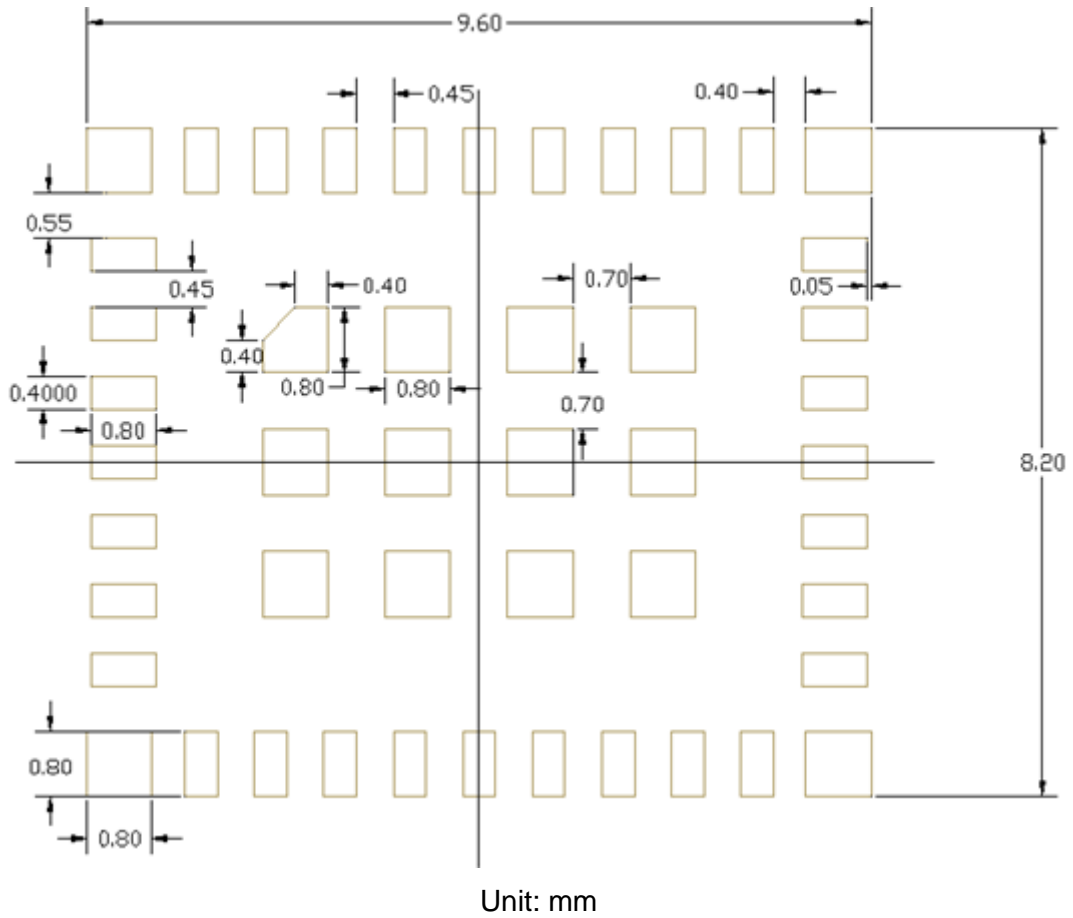

Reference Circuit

Figure 6: Reference Circuit

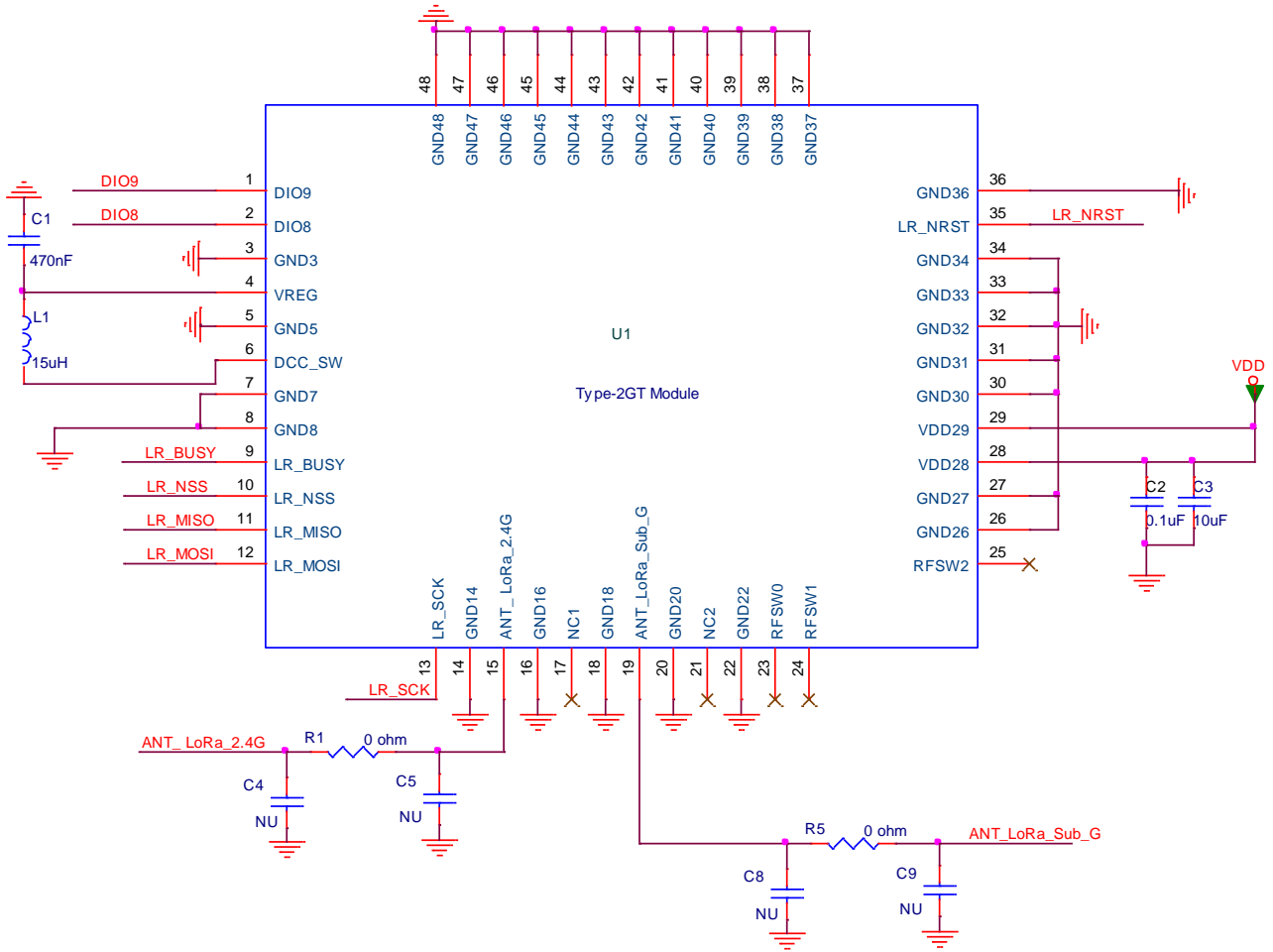

14 General Regulatory Certification for LBAA0XV2GT

This section contains the following topics:

- Application model part number
- Label
- Package Label
- Country of Origin

14.1 Application Model Part Number

Basically, we apply for “LBAA0XV2GT” in each country.

14.2 Label

Figure 7 shows the label of Type 2GT module.

Figure 7: Type 2GT Module Label



14.3 Package Label

Figure 8 shows the Radio Regulatory Certification label on the humidity package.

Figure 8: Package Label Display



14.4 Country of Origin

China

SHENZHEN MURATA TECHNOLOGY CO., LTD.

Some countries have applied for two countries, China and Japan, in preparation for future factory changes, but the production site in the delivery specifications is the above-mentioned factory in China.

15 Radio Regulatory Certification by Country for LBAA0XV2GT

This section includes the following regulatory certifications:

- JRL
- FCC
- ISED
- CE

15.1 JRL

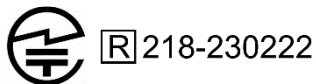

15.2 FCC

FCC ID : VPYLB2GT

15.3 ISED

IC : 772C-LB2GT

15.4 CE

Compliant with EN 300220-2 V3.2.1, EN 300440 V2.2.1, EN IEC 62311:2020

16 Tape and Reel Packing

This section provides the general specifications for tape and reel packing.

16.1 Dimensions of Tape (Plastic Tape)

The dimension of the tape is as follows:

- The corner and ridge radiuses (R) of inside cavity are 0.3 mm maximum.
- Cumulative tolerance of 10 pitches of the sprocket hole is ± 0.15 mm
- Measuring of cavity positioning is based on cavity center in accordance with JIS/IES standard.

Figure 9 is a graphical representation of the tape dimension (plastic tape).

Figure 9: Dimensions of Tape (Plastic tape)

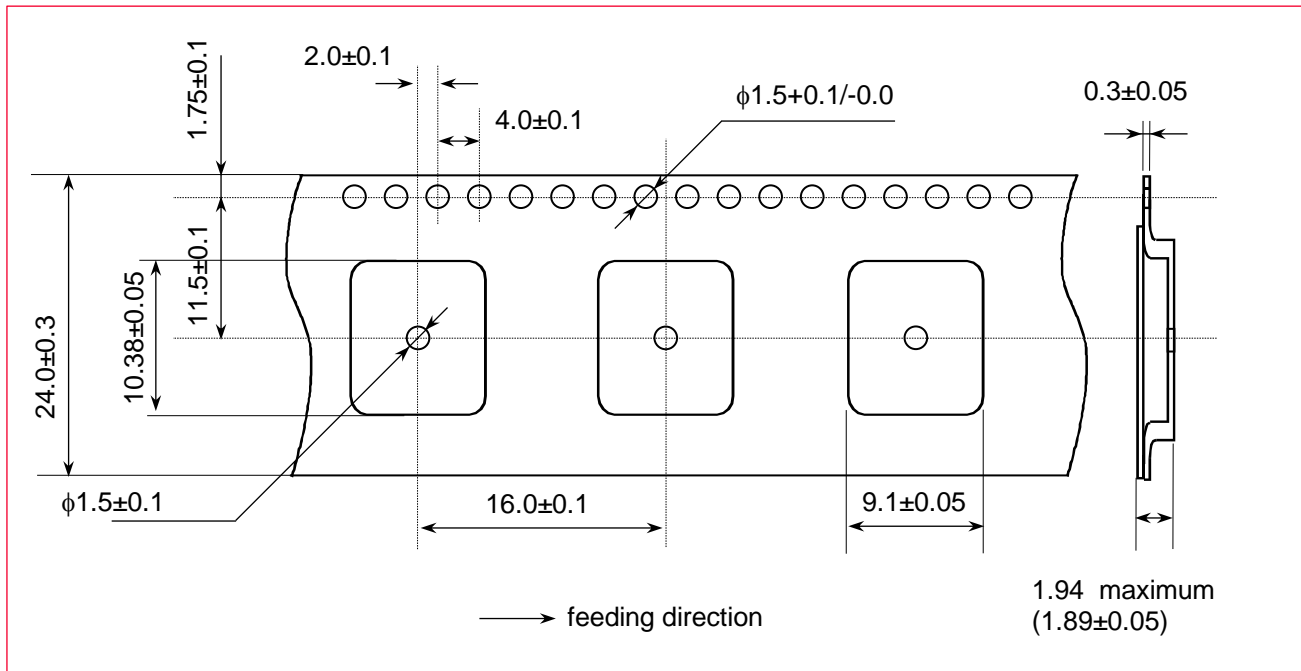

16.2 Dimensions of Reel

Figure 10 shows the reel dimensions.

Figure 10: Dimensions of Reel (Unit: mm)

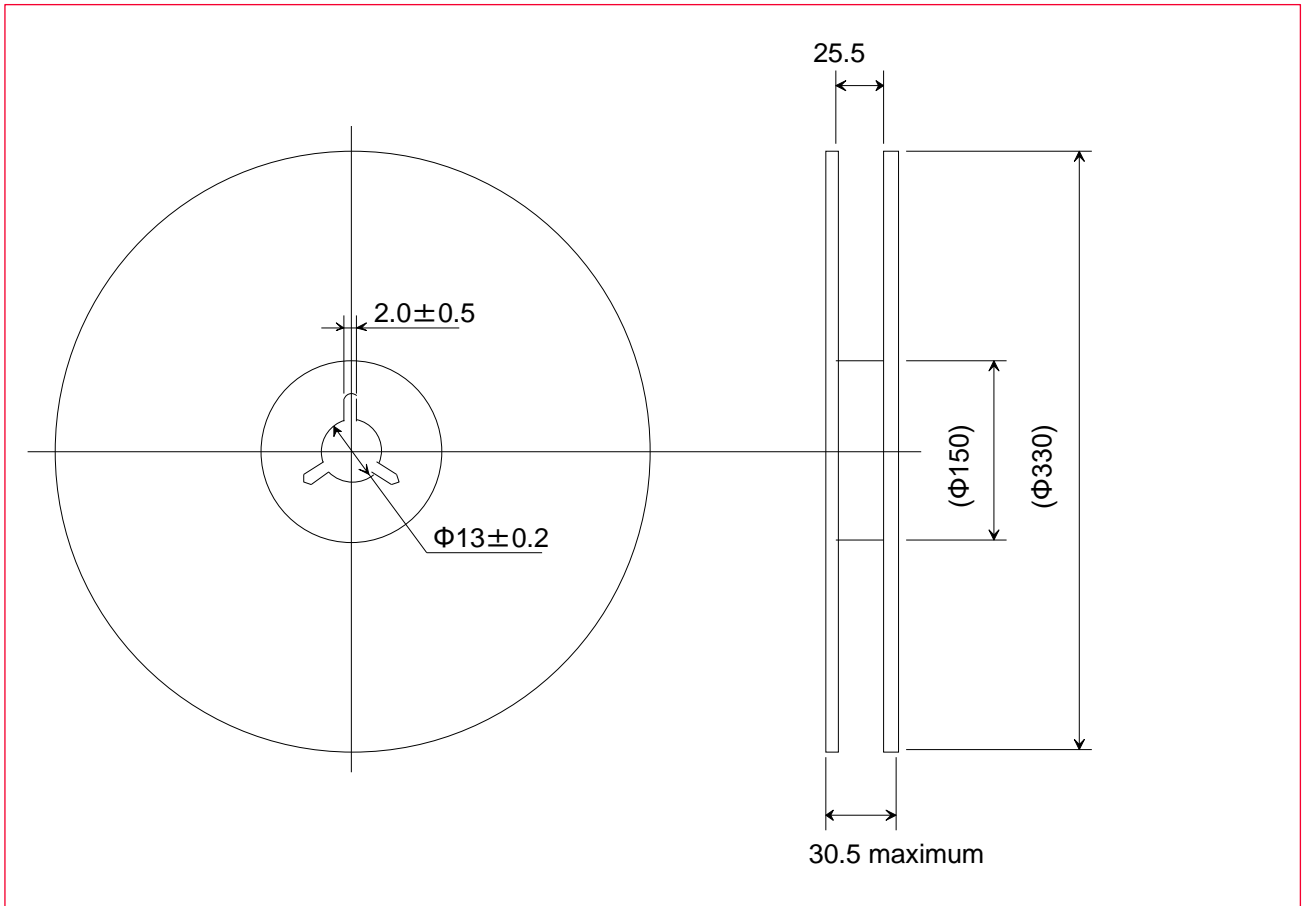

16.3 Taping Diagrams

Figure 11 shows the tapings diagrams.

Figure 11: Taping Diagrams

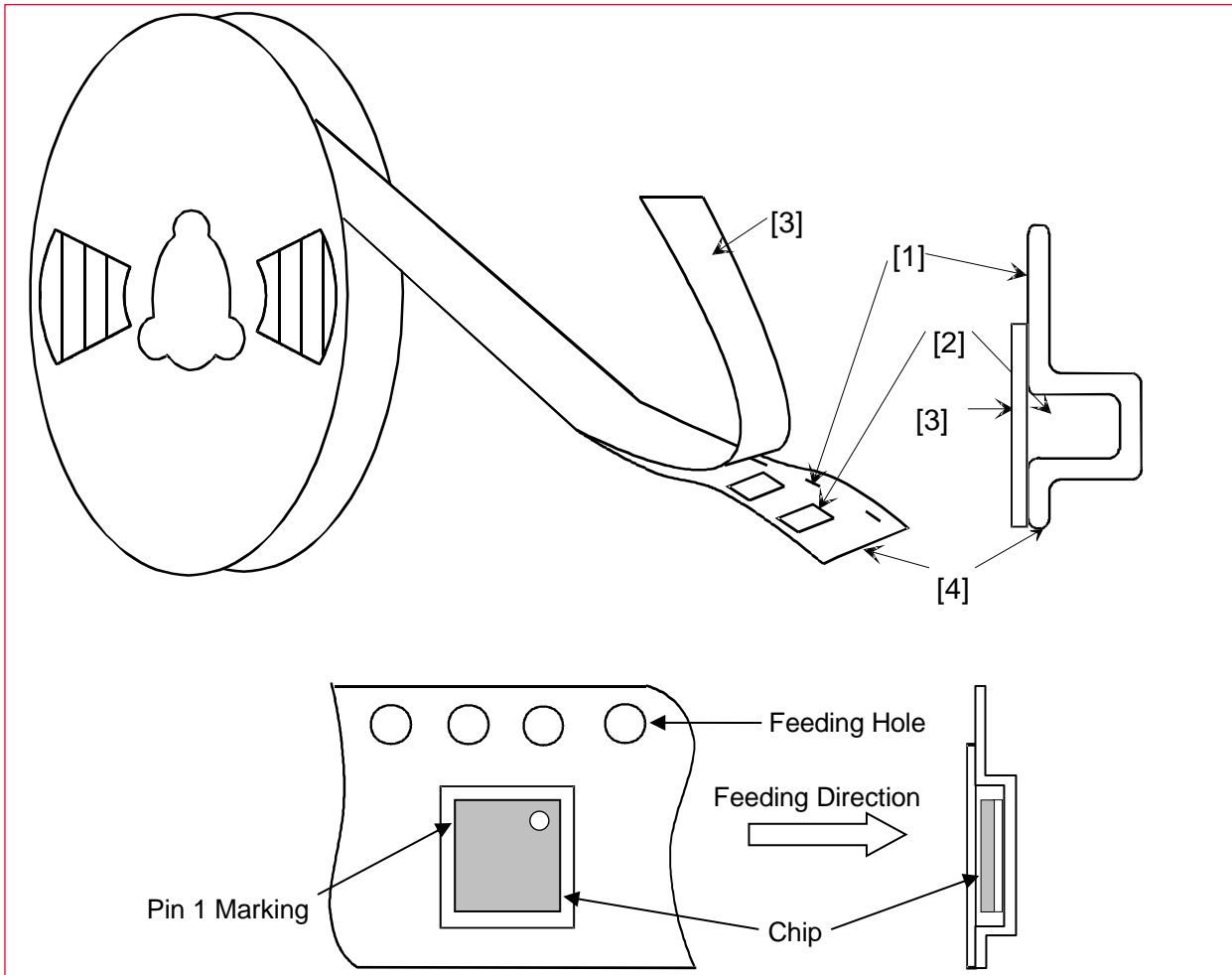

Table 14: Taping Specifications

Mark	Description
1	Feeding hole. As specified in Dimensions of Tape (Plastic tape) ☞.
2	Hole for Chip. As specified in Dimensions of Tape (Plastic tape) ☞.
3	Cover tape. 62 μm in thickness.
4	Base tape. As specified in Dimensions of Tape (Plastic tape) ☞.

16.4 Leader and Tail Tape

The leader and tail tape are shown in [Figure 12](#).

Figure 12: Leader and Tail Tape

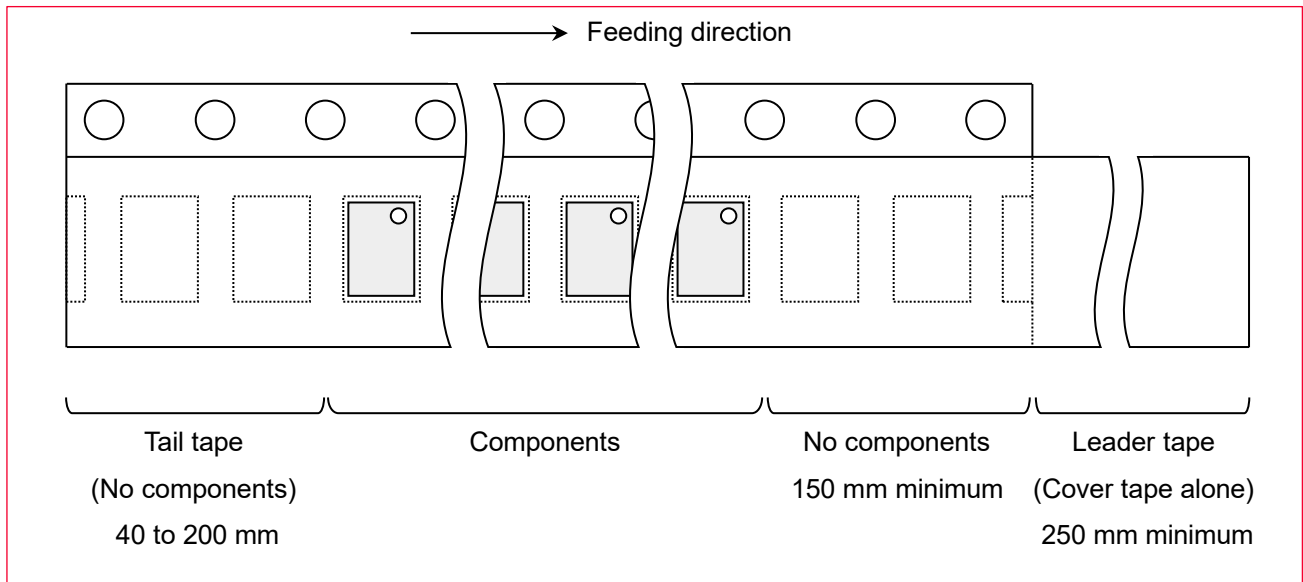

- The tape for chips is wound clockwise, the feeding holes to the right side as the tape is pulled toward the user.
- The cover tape and base tape are not adhered at no components area for 250 mm minimum
- Tear off strength against pulling of cover tape: 5 N minimum
- Packaging unit: 800 pcs. / Reel
- Tape material:
 - Base tape: Plastic
 - Reel: Plastic
 - Cover tape, cavity tape and reel are made the anti-static processing.
- Peeling off force: 1.3 N maximum in the direction of peeling as shown in [Figure 13](#).

Figure 13: Peeling Force

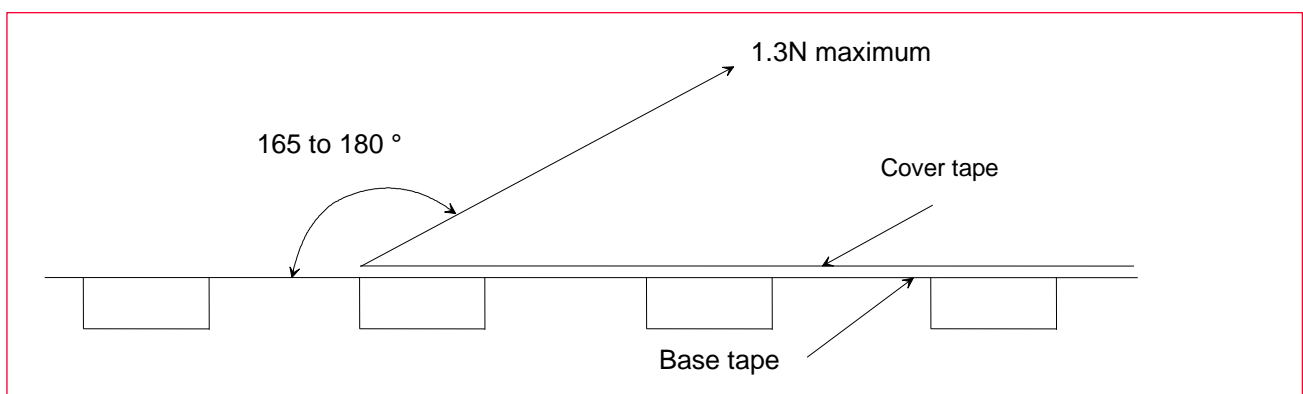

16.5 Packaging (Humidity Proof Packing)

Figure 14 shows the humidity proof packaging.

Figure 14: Humidity Proof Packaging

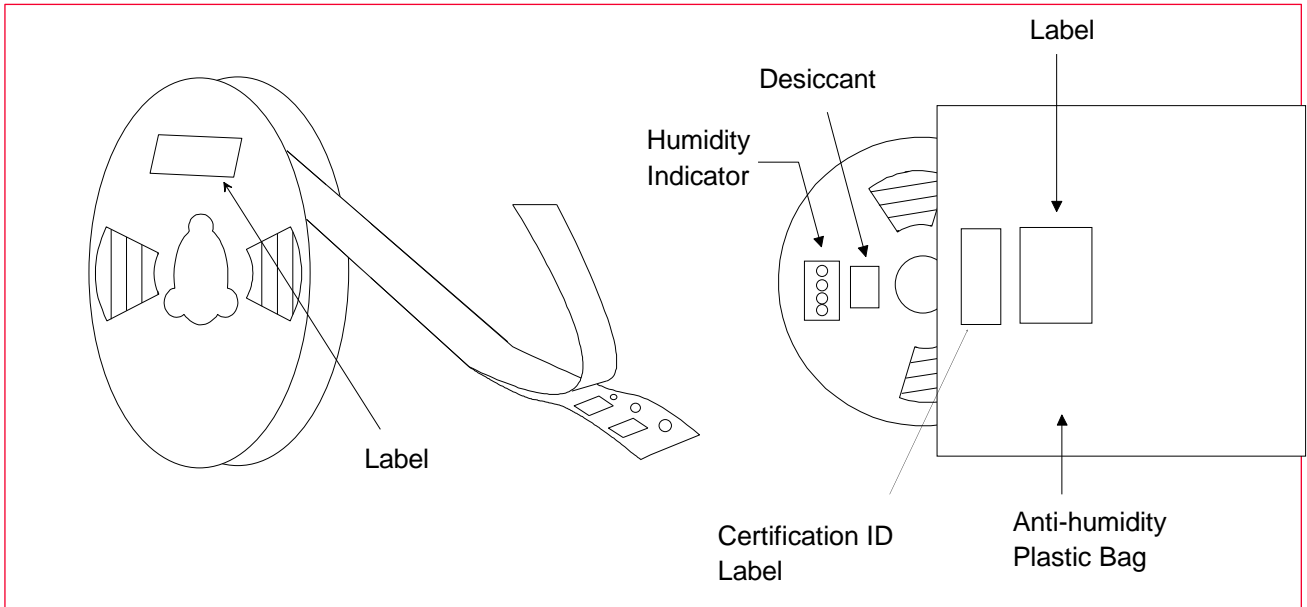

Tape and reel must be sealed with the anti-humidity plastic bag. The bag contains the desiccant and the humidity indicator.

17 Notice

17.1 Storage Conditions

- Please use this product within 6 months after receipt.
- The product shall be stored without opening the packing under the ambient temperature from 5 to 35 °C and humidity from 20 ~ 70 %RH (Packing materials may be deformed at the temperature over 40 °C).
- The product left more than 6 months after reception; it needs to be confirmed the solderability before used.
- The product *must* be stored in noncorrosive gas (Cl₂, NH₃, SO₂, NO_x, etc.).
- Any excess mechanical shock including, but not limited to, sticking the packing materials by sharp object and dropping the product, *must* not be applied in order not to damage the packing materials.
- This product is applicable to MSL3 (Based on JEDEC Standard J-STD-020)
 - After the packing opened, the product *must* be stored at ≤30 °C / <60 %RH and the product *should* be used within 168 hours after opening.
 - When the color of the indicator in the packing changed, the product shall be baked before soldering.
- Baking condition: 125 +5/-0 °C, 24 hours, 1 time
- The products must be baked on the heat-resistant tray because the material (Base Tape, Reel Tape and Cover Tape) is not heat-resistant.

17.2 Handling Conditions

- Be careful in handling or transporting products because excessive stress or mechanical shock may break products.
- Handle with care if products may have cracks or damages on their terminals. If there is any such damage, the characteristics of products may change. *Do not touch* products with bare hands that may result in poor solder ability and destroy by static electrical charge.

17.3 Standard PCB Design (Land Pattern and Dimensions)

- All the ground terminals should be connected to the ground patterns. Furthermore, the ground pattern should be provided between IN and OUT terminals. Please refer to the specifications for the standard land dimensions.
- The recommended land pattern and dimensions is as Murata's standard. The characteristics of products may vary depending on the pattern drawing method, grounding method, land dimensions, land forming method of the NC terminals and the PCB material and thickness. Therefore, be sure to verify the characteristics in the actual set. When using non-standard lands, contact Murata beforehand.

17.4 Notice for Chip Placer

When placing products on the PCB, products may be stressed and broken by uneven forces from a worn-out chucking locating claw or a suction nozzle. To prevent products from damages, be sure to follow the specifications for the maintenance of the chip placer being used. For the positioning of products on the PCB, be aware that mechanical chucking may damage products.

17.5 Soldering Conditions

The recommendation conditions of soldering are as in the following figure.

Soldering must be carried out by the above-mentioned conditions to prevent products from damage. Set up the highest temperature of reflow within 260 °C. Contact Murata before use if concerning other soldering conditions.

Figure 15: Reflow soldering standard conditions (Example)

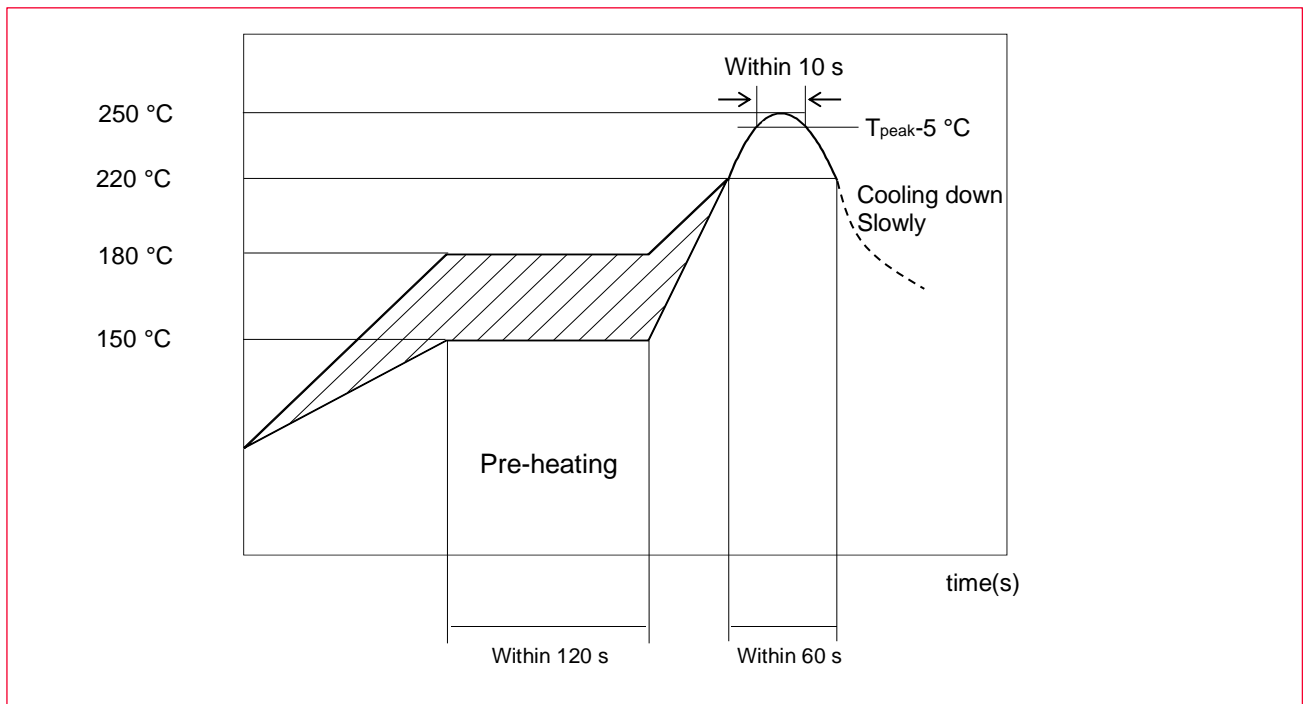

Please use the reflow within 2 times.

Use rosin type flux or weakly active flux with a chlorine content of 0.2 wt % or less.

17.6 Cleaning

Since this Product is Moisture Sensitive, any cleaning is not recommended. If any cleaning process is done the customer is responsible for any issues or failures caused by the cleaning process.

17.7 Operational Environment Conditions

Products are designed to work for electronic products under normal environmental conditions (ambient temperature, humidity, and pressure). Therefore, products have no problems to be used under the similar conditions to the above-mentioned. However, if products are used under the following circumstances, it may damage products and leakage of electricity and abnormal temperature may occur.

- In an atmosphere containing corrosive gas (Cl₂, NH₃, SO_x, NO_x etc.).
- In an atmosphere containing combustible and volatile gases.
- Dusty place.
- Direct sunlight place.
- Water splashing place.
- Humid place where water condenses.
- Freezing place.



If there are possibilities for products to be used under the preceding clause, consult with Murata before actual use.



Do not apply static electricity or excessive voltage while assembling and measuring, as it might be a cause of degradation or destruction to apply static electricity to products.

17.8 Input Power Capacity

Products shall be used in the input power capacity as specified in this specification.

Inform Murata beforehand, in case that the components are used beyond such input power capacity range.

18 Preconditions to Use Our Products



PLEASE READ THIS NOTICE BEFORE USING OUR PRODUCTS.

Please make sure that your product has been evaluated and confirmed from the aspect of the fitness for the specifications of our product when our product is mounted to your product.

All the items and parameters in this product specification/datasheet/catalog have been prescribed on the premise that our product is used for the purpose, under the condition and in the environment specified in this specification. You are requested not to use our product deviating from the condition and the environment specified in this specification.

Please note that the only warranty that we provide regarding the products is its conformance to the specifications provided herein. Accordingly, we shall not be responsible for any defects in products or equipment incorporating such products, which are caused under the conditions other than those specified in this specification.

WE HEREBY DISCLAIM ALL OTHER WARRANTIES REGARDING THE PRODUCTS, EXPRESS OR IMPLIED, INCLUDING WITHOUT LIMITATION ANY WARRANTY OF FITNESS FOR A PARTICULAR PURPOSE, THAT THEY ARE DEFECT-FREE, OR AGAINST INFRINGEMENT OF INTELLECTUAL PROPERTY RIGHTS.

You agree that you will use any and all software or program code (including but not limited to hcd, firmware, nvram, and blob) we may provide or to be embedded into our product ("Software") provided that you use the Software bundled with our product. YOU AGREE THAT THE SOFTWARE SHALL BE PROVIDED TO YOU "AS IS" BASIS, MURATA MAKES NO REPRESENTATIONS OR WARRANTIES THAT THE SOFTWARE IS ERROR-FREE OR WILL OPERATE WITHOUT INTERRUPTION. AND MORE, MURATA MAKES NO REPRESENTATIONS OR WARRANTIES OF ANY KIND WHETHER EXPRESS OR IMPLIED WITH RESPECT TO THE SOFTWARE. MURATA EXPRESSLY DISCLAIM ANY AND ALL WARRANTIES OR CONDITIONS OF MERCHANTABILITY, FITNESS FOR A PARTICULAR PURPOSE NOR THE WARRANTY OF TITLE OR NON-INFRINGEMENT OF INTELLECTUAL PROPERTY RIGHTS.

You shall indemnify and hold harmless us, our affiliates, and our licensor from and against any and all claims, costs, expenses and liabilities (including attorney's fees), which arise in connection with the using the Software.

The product shall not be used in any application listed below which requires especially high reliability for the prevention of such defect as may directly cause damage to the third party's life, body or property. You acknowledge and agree that, if you use our products in such applications, we will not be responsible for any failure to meet such requirements. Furthermore, YOU AGREE TO INDEMNIFY AND DEFEND US AND OUR AFFILIATES AGAINST ALL CLAIMS, DAMAGES, COSTS, AND EXPENSES THAT MAY BE INCURRED, INCLUDING WITHOUT LIMITATION, ATTORNEY FEES AND COSTS, DUE TO THE USE OF OUR PRODUCTS AND THE SOFTWARE IN SUCH APPLICATIONS.

- Aircraft equipment.
- Aerospace equipment.
- Undersea equipment.
- Power plant control equipment.
- Medical equipment.
- Traffic signal equipment.

- Burning / explosion control equipment.
- Disaster prevention / crime prevention equipment.
- Transportation equipment (vehicles, trains, ships, elevator, etc.).
- Application of similar complexity and/ or reliability requirements to the applications listed in the above.

We expressly prohibit you from analyzing, breaking, reverse-engineering, remodeling altering, and reproducing our product. Our product cannot be used for the product which is prohibited from being manufactured, used, and sold by the regulations and laws in the world.

We do not warrant or represent that any license, either express or implied, is granted under any our patent right, copyright, mask work right, or our other intellectual property right relating to any combination, machine, or process in which our products or services are used. Information provided by us regarding third-party products or services does not constitute a license from us to use such products or services or a warranty or endorsement thereof. Use of such information may require a license from a third party under the patents or other intellectual property of the third party, or a license from us under our patents or other intellectual property.

Please do not use our products, our technical information and other data provided by us for the purpose of developing of mass-destruction weapons and the purpose of military use.

Moreover, you must comply with "foreign exchange and foreign trade law", the "U.S. export administration regulations", etc.

Please note that we may discontinue the manufacture of our products, due to reasons such as end of supply of materials and/or components from our suppliers.

By signing on specification sheet or approval sheet, you acknowledge that you are the legal representative for your company and that you understand and accept the validity of the contents herein. When you are not able to return the signed version of specification sheet or approval sheet within 30 days from receiving date of specification sheet or approval sheet, it shall be deemed to be your consent on the content of specification sheet or approval sheet. Customer acknowledges that engineering samples may deviate from specifications and may contain defects due to their development status. We reject any liability or product warranty for engineering samples. In particular we disclaim liability for damages caused by

- The use of the engineering sample other than for evaluation purposes, particularly the installation or integration in the product to be sold by you,
- Deviation or lapse in function of engineering sample,
- Improper use of engineering samples.

We disclaim any liability for consequential and incidental damages.

If you can't agree with the above contents, please contact sales.

Revision History

Revision Code	Date	Changed Item	Comment
-	2023.03.21	First version	
A	2023.5.22	1.Updated the DC/RF characters. 2.Added the ref design.	
B	2023.12.28	1. Updated the certification ID 2. Updated the DC/RF characters. 3. Added packing information.	



Copyright © Murata Manufacturing Co., Ltd. All rights reserved. The information and content in this document are provided “as-is” with no warranties of any kind and are for informational purpose only. Data and information have been carefully checked and are believed to be accurate; however, no liability or responsibility for any errors, omissions, or inaccuracies is assumed.

Specifications are subject to change without notice.