

Terminal blocks with screw connection for junction boxes, type *WKI*

selos BITOS

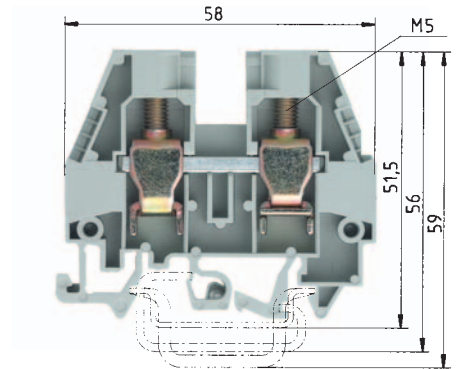
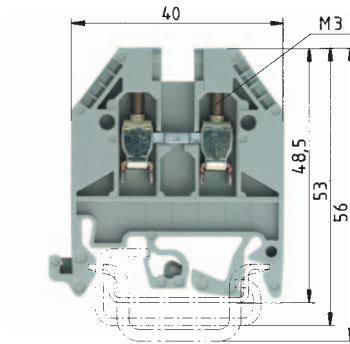

WK 4/U

fine-stranded	solid	V	A
0.5 – 4 mm ²	0.5 – 6 mm ²	800 V/8 kV/3	32
No. 22-10 AWG		600 V	30/35
No. 20-10 AWG		600 V	40
6 mm			9 mm

WKI 10/U

fine-stranded	solid/stranded	V	A
1 – 10 mm ²	1.5 – 16 mm ²	400 V/6 kV/3	57
No. 16-6 AWG		600 V	65/65
No. 16-6 AWG		600 V	70
10 mm			18 mm

EN 60 947-7-1/DIN VDE 0611 T1

UL ratings field/factory wiring

CSA ratings

Width Wire strip length

Approvals

	Type	Part No.	Std. Pack	Type	Part No.	Std. Pack
Feed-through block	gray	WK 4/U	57.504.0055.0 100	WKI 10/U	57.510.1155.0 50	
Feed-through block	blue	WK 4/U BLAU	57.504.0055.6 100	WKI 10/U BLAU	57.510.1155.6 50	
Accessories						
1. Mounting rail TS 35, DIN rail 7.5 mm high L = 2 m		35 x 27 x 7.5 EN 60715	98.300.0000.0 1	35 x 27 x 7.5 EN 60715	98.300.0000.0 1	
Mounting rail TS 35, DIN rail 15 mm high L = 2 m		35 x 27 x 15 EN 60715	98.360.0000.0 1	35 x 27 x 15 EN 60715	98.360.0000.0 1	
2. End clamp for TS 35, with screw 8 mm wide		9708/2 S35	Z5.522.8553.0 100	9708/2 S35	Z5.522.8553.0 100	
End clamp for TS 35, without screws 8 mm wide		WEF 1/35	Z5.523.9353.0 100	WEF 1/35	Z5.523.9353.0 100	
3. End plate 1.5 mm thick gray		AP 2,5-4	07.311.0155.0 10			
1.5 mm thick blue		AP 2,5-4 BLAU	07.311.0155.6 10			
1.5 mm thick green						
End plate 2 mm thick gray				API 10-16	07.311.9455.0 10	
2 mm thick blue				API 10-16 BLAU	07.311.9455.6 10	
2 mm thick green						
4. Partition plate gray		TW 2,5-4	07.311.1155.0 10			
blue		TW 2,5-4 BLAU	07.311.1155.6 10			
5. Cross connector with screws (jumper bar) 2 pole		IVB WK 4-2	Z7.281.1227.0 10	IVB WKN 10-2	Z7.283.2227.0 10	
insulated 3 pole		IVB WK 4-3	Z7.281.1327.0 10	IVB WKN 10-3	Z7.283.2327.0 10	
4 pole		IVB WK 4-4	Z7.281.1427.0 10	IVB WKN 10-4	Z7.283.2427.0 10	
5 pole		IVB WK 4-5	Z7.281.1527.0 10	IVB WKN 10-5	Z7.283.2527.0 10	
6 pole		IVB WK 4-6	Z7.281.1627.0 10	IVB WKN 10-6	Z7.283.2627.0 10	
6. Partition plate with marking facility yellow		TS 4 GELB	07.311.2153.8 10	TS 10 GELB	07.311.2353.8 10	
7. Cover with marking facility yellow		AD VB 4 GELB	04.326.2153.8 10	AD VB 10 GELB	04.342.1056.8 10	
8. Cover with warning symbol over 4 blocks yellow		AB VB 6/4 GELB	04.343.4856.8 10			
Cover with warning symbol for 1 block yellow				ADI 10/1 GELB	04.325.8553.8 10	
9. Busbar						
E-Cu 10 x 3 mm, tin-plated, I _N = 140 A L = 1 m						
E-Cu 10 x 3 mm, unplated, I _N = 140 A L = 1 m						
10. Connector clamp for busbar						
16 mm ² 8.5 mm wide						
35 mm ² 17 mm wide						
11. Busbar support 4 mm wide						
Busbar support 8 mm wide						
Marking accessories see page 230-237						

Terminal blocks with screw connection for junction boxes, type *WKI*

setos

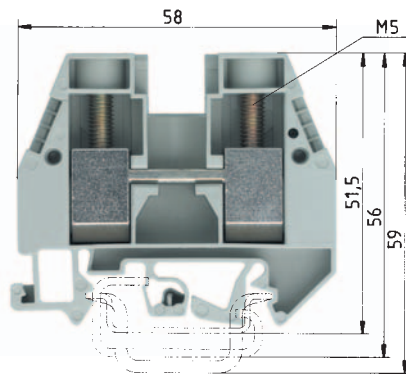
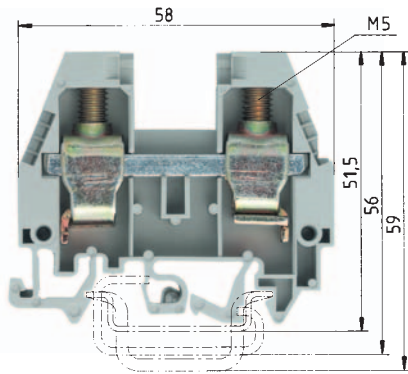

WKI 16/U

fine-stranded	solid/stranded	V	A
1 – 16 mm ²	15 – 25 mm ²	400 V/6 kV/3	76
No. 12-4 AWG		600 V	65/90
No. 14-4 AWG		600 V	95
12 mm			16 mm



WKI 35/U

fine-stranded	stranded	V	A
16 – 35 mm ²	16 – 50 mm ²	400 V/6 kV/3	125
No. 10-2 AWG		600 V	95/95
No. 10-2 AWG		600 V	110
16 mm			13 mm



Type	Part No.	Std. Pack	Type	Part No.	Std. Pack
WKI 16/U	57.516.1155.0	50	WKI 35/U	57.535.1155.0	20
WKI 16/U BLAU	57.516.1155.6	50	WKI 35/U BLAU	57.535.1155.6	20
35 x 27 x 7,5 EN 60715	98.300.0000.0	1	35 x 27 x 7,5 EN 60715	98.300.0000.0	1
35 x 27 x 15 EN 60715	98.360.0000.0	1	35 x 27 x 15 EN 60715	98.360.0000.0	1
9708/2 S 35	Z5.522.8553.0	100	9708/2 S 35	Z5.522.8553.0	100
API 10-16	07.311.9455.0	10	API 35	07.311.8855.0	10
API 10-16 BLAU	07.311.9455.6	10	API 35 BLAU	07.311.8855.6	10
IVB WKI 16-2	Z7.284.9227.0	10	IVB WKI 35-2	Z7.285.4227.0	5
IVB WKI 16-3	Z7.284.9327.0	10	IVB WKI 35-3	Z7.285.4327.0	5
IVB WKI 16-4	Z7.284.9427.0	10	IVB WKI 35-4	Z7.285.4427.0	5
IVB WKI 16-5	Z7.284.9527.0	10	IVB WKI 35-5	Z7.285.4527.0	5
IVB WKI 16-6	Z7.284.9627.0	10	IVB WKI 35-6	Z7.285.4627.0	5
TS 16 GELB	07.311.2453.8	10	TS 35 GELB	07.311.8653.8	10
AD VB 16 GELB	04.326.2453.8	10			
ADI 16/1 GELB	04.325.8653.8	10	ADI 35/1 GELB	04.325.8753.8	10

Neutral disconnect blocks with screw connection for junction boxes, type WKI

selos BIT

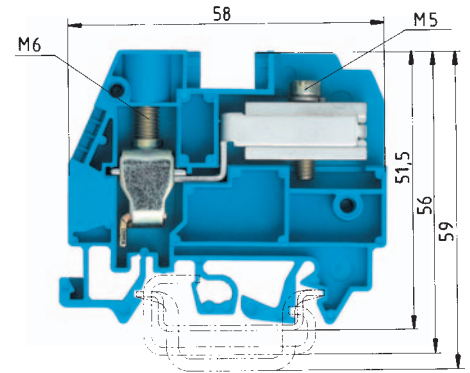
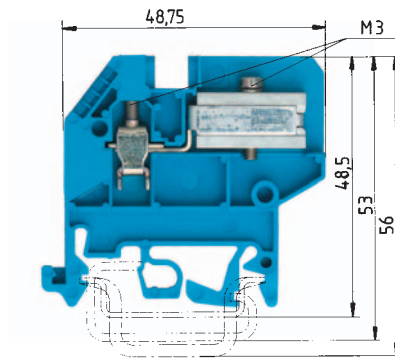

***) for use in grounded networks

Current carrying capability:
 fine-stranded: 4 mm² 25 A
 solid: 6 mm² 30 A

Current carrying capability:
 fine-stranded: 10 mm² 45 A
 stranded: 16 mm² 50 A

WKN 4 ETK/U

fine-stranded solid V A
 0.5 – 4 mm² 0.5 – 6 mm² 400 V/6 kV/3***)

WKI 10 ETK/U

fine-stranded solid/stranded V A
 1 – 10 mm² 1 – 16 mm² 400 V/6 kV/3***)

EN 60 947-7-1/DIN VDE 0611 T1

UL ratings

CSA ratings

Width

Approvals

Wire strip length

No. 20-10 AWG600 V

25

6 mm

9 mm



No. 16-6 AWG

600 V 45

10 mm

13 mm



	Type	Part No.	Std. Pack	Type	Part No.	Std. Pack
Neutral-disconnect block	blue	WKN 4 ETK/U	57.504.8155.0 100	WKI 10 ETK/U	57.510.8255.0 50	
Connector clamp for Cu busbar	blue					
	unplated					
Accessories						
1. Mounting rail TS 35, DIN rail 7.5mm high L = 2 m	35 x 27 x 7,5 EN 60715	98.300.0000.0	1	35 x 27 x 7,5 EN 60715	98.300.0000.0	1
Mounting rail TS 35, DIN rail 15mm high L = 2 m	35 x 27 x 15 EN 60715	98.360.0000.0	1	35 x 27 x 15 EN 60715	98.360.0000.0	1
2. End clamp for TS 35, with screw 8 mm wide	9708/2 S35	Z5.522.8553.0	100	9708/2 S35	Z5.522.8553.0	100
End clamp for TS 35, without screws 8 mm wide	WEF 1/35	Z5.523.9353.0	100	WEF 1/35	Z5.523.9353.0	100
3. End plate 1.5 mm thick gray						
	1.5 mm thick blue	APN 4 ETK	07.311.1155.0 10	API 10-16 ETK/1	07.312.1955.0 10	
	1.5 mm thick green					
End plate 2 mm thick gray						
	2 mm thick blue					
	2 mm thick green					
4. Partition plate gray						
	blue					
5. Cross connector with screws (jumper bar) 2 pole						
insulated 3 pole						
	4 pole					
	5 pole					
	6 pole					
6. Partition plate with marking facility yellow						
7. Cover with marking facility yellow						
8. Cover with warning symbol over 4 blocks yellow						
Cover with warning symbol for 1 block yellow						
9. Busbar						
E-Cu 10 x 3 mm, unplated, I _N = 140 L = 1 m	9813 M	98.290.0000.0	1	9813 M	98.290.0000.0	1
E-Cu 10 x 3 mm, tin-plated, I _N = 140 A L = 1 m	9813 M SN	98.290.1000.0	1	9813 M SN	98.290.1000.0	1
10. Connector clamp for busbar						
16 mm ² 8.5 mm wide	WAK 16/2 BLAU	30.494.3021.6	100	WAK 16/2 BLAU	30.494.3021.6	100
35 mm ² 17 mm wide	WAK 35/2	30.494.4121.0	50	WAK 35/2	30.494.4121.0	50
11. Busbar support 4 mm wide	WKI SH/U	01.108.3255.0	10	WKI SH/U	01.108.3255.0	10
Busbar support 8 mm wide	WKIF SH/E/35	Z1.108.8453.0	100	WKIF SH/E/35	Z1.108.8453.0	100
Marking accessories see page 230-237						

Connector clamp for Cu busbar (10 x 3 mm), type WAK

selos

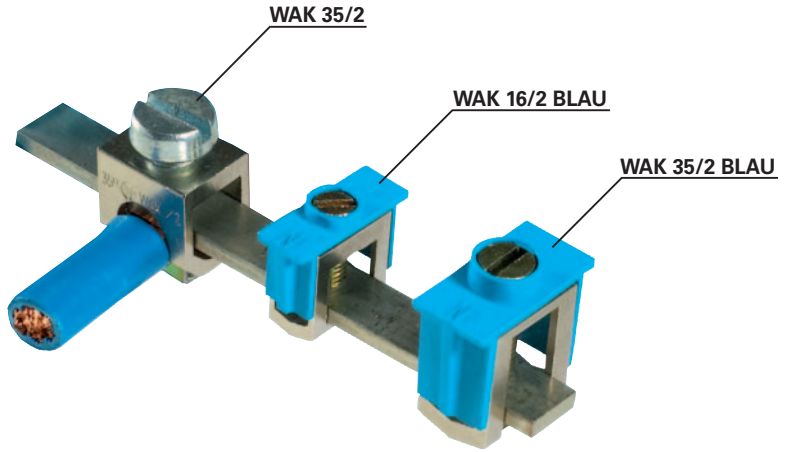
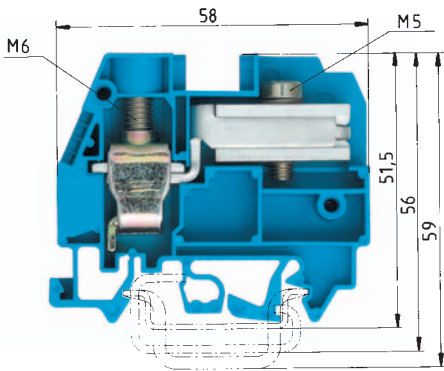

Current carrying capability:
 fine-stranded: 16 mm² 62 A
 stranded: 25 mm² 67 A

EN 60 998-2-1 CCA/CH

EN 60 998-2-1 CCA/CH

WKI 16 ETK/U

fine-stranded solid/stranded V A
 1 – 16 mm² 1 – 25 mm² 400 V/6 kV/3***)

WAK 16/2

fine-stranded stranded V A
 1.5 – 16 mm² 10 – 16 mm² 76

WAK 35/2

fine-stranded stranded V A
 16 – 35 mm² 16 – 35 mm² 125

No. 14-4 AWG 600 V 65
 12 mm 15 mm

8.4 mm 16 mm

17 mm 14 mm



Type	Part No.	Std. Pack	Type	Part No.	Std. Pack	Type	Part No.	Std. Pack
WKI 16 ETK/U	57.516.8255.0	50	WAK 16/2 BLAU	30.494.3021.6	100	WAK 35/2 BLAU	30.494.4021.0	50
						WAK 35/2	30.494.4121.0	50
35 x 27 x 7,5 EN 60715	98.300.0000.0	1						
35 x 27 x 15 EN 60715	98.360.0000.0	1						
9708/2 S35	Z5.522.8553.0	100						
API 10-16 ETK/1	07.312.1955.0	10						
9813 M	98.290.0000.0	1	9813 M	98.290.0000.0	1	9813 M	98.290.0000.0	1
9813 M SN	98.290.1000.0	1	9813 M SN	98.290.1000.0	1	9813 M SN	98.290.1000.0	1
WAK 16/2 BLAU	30.494.3021.6	100						
WAK 35/2	30.494.4121.0	50						
WKI SH/U	01.108.3255.0	10	WKI SH/U	01.108.3255.0	10	WKI SH/U	01.108.3255.0	10
WKIF SH/E/35	Z1.108.8453.0	100	WKIF SH/E/35	Z1.108.8453.0	100	WKIF SH/E/35	Z1.108.8453.0	100

Ground blocks with screw connection for junction boxes, type **WKI SL**

selos BIT

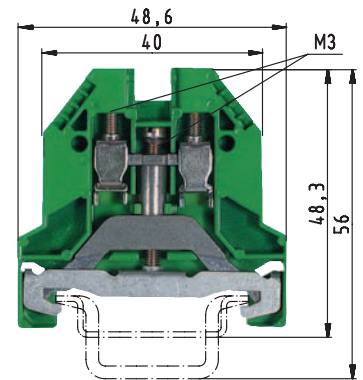
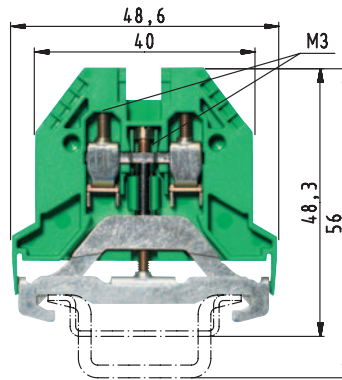

*) Ratings of adjacent feed-through block same series and size

EN 60 947-7-2/DIN VDE 0611 T3
UL ratings
CSA ratings
Width
Approvals

Wire strip length

WK 2,5 SL/35

fine-stranded solid V A
0.5 – 2.5 mm² 0.5 – 4 mm² 500 V/6 kV/3*)
No. 22-12 AWG
No. 24-12 AWG
5 mm 9 mm

WK 4 SL/35

fine-stranded solid V A
0.5 – 4 mm² 0.5 – 6 mm² 800 V/8 kV/3*)
No. 22-10 AWG
No. 22-10 AWG
6 mm 9 mm

			Type	Part No.	Std. Pack	Type	Part No.	Std. Pack
Ground block	with U-foot	green/yellow	WK 2,5 SL/35	56.503.9055.0	100			
Ground block	for TS 35	green/yellow				WK 4 SL/35	56.504.9055.0	100
Accessories								
1. Mounting rail TS 35, DIN rail 7.5 mm high	L = 2 m		35 x 27 x 7,5 EN 60715	98.300.0000.0	1	35 x 27 x 7,5 EN 60715	98.300.0000.0	1
Mounting rail TS 35, DIN rail 15 mm high	L = 2 m		35 x 27 x 15 EN 60715	98.360.0000.0	1	35 x 27 x 15 EN 60715	98.360.0000.0	1
2. End clamp for TS 35, with screw	8 mm wide					9708/2 S35	Z5.522.8553.0	100
End clamp for TS 35, without screws	8 mm wide					WEF 1/35	Z5.523.9353.0	100
3. End plate	1.5 mm thick	gray						
	1.5 mm thick	blue						
	1.5 mm thick	green	AP 2,5-4 SL	07.311.7155.0	10	AP 2,5-4 SL	07.311.7155.0	10
End plate	2 mm thick	gray						
	2 mm thick	blue						
	2 mm thick	green						
4. Partition plate		gray						
		blue						
5. Cross connector with screws (jumper bar)	2 pole							
insulated	3 pole							
	4 pole							
	5 pole							
	6 pole							
6. Partition plate with marking facility		yellow						
7. Cover with marking facility		yellow	AD VB 2,5 GELB	04.326.2053.8	10	AD VB4 GELB	04.326.2153.8	10
8. Cover with warning symbol over 4 blocks		yellow	AD VB 5/4 GELB	04.343.4756.8	10	AD VB 6/4 GELB	04.343.4856.8	10
Cover with warning symbol for 1 block		yellow						
9. Busbar								
E-Cu 10 x 3 mm, tin-plated, I _N = 140	L = 1 m							
E-Cu 10 x 3 mm, unplated, I _N = 140 A	L = 1 m							
10. Connector clamp for busbar								
	16 mm ²	8.5 mm wide						
	35 mm ²	17 mm wide						
11. Busbar support		4 mm wide						
Busbar support		8 mm wide						
Marking accessories see page 230-237								

Ground blocks with screw connection for junction boxes, type **WKI SL**

setos

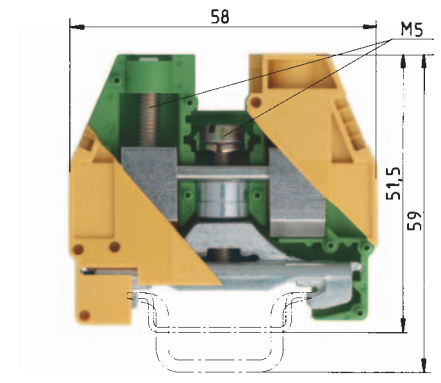
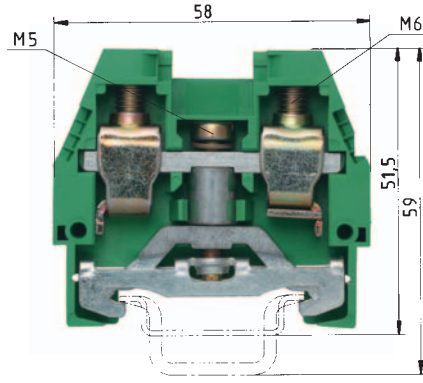
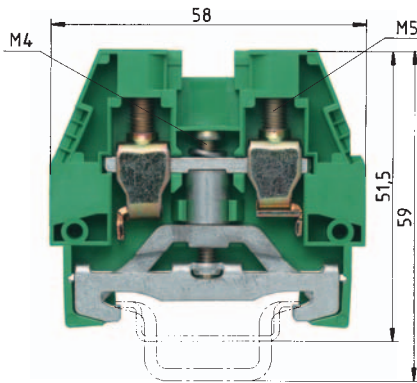

enclosed design

WKI 10 SL/35

fine-stranded solid/stranded V A
 1 – 10 mm² 1.5 – 16 mm² 800 V/8 kV/3*)
 No. 16-6 AWG 600 V*)
 No. 16-6 AWG
 10 mm 18 mm



WKI 16 SL/35

fine-stranded solid/stranded V A
 1 – 16 mm² 1.5 – 25 mm² 400 V/6 kV/3*)
 No. 12-4 AWG 600 V*)
 12 mm 16 mm



WKI 35 SL/35

fine-stranded stranded V A
 16 – 35 mm² 16 – 50 mm² 400 V/6 kV/3*)
 No. 10-2 AWG
 16 mm 13 mm



Type	Part No.	Std. Pack	Type	Part No.	Std. Pack	Type	Part No.	Std. Pack
WKI 10 SL/35	56.510.9255.0	50	WKI 16 SL/35	56.516.9255.0	50	WKI 35 SL/35	56.535.9255.0	20
35 x 27 x 7,5 EN 60715	98.300.0000.0	1	35 x 27 x 7,5 EN 60715	98.300.0000.0	1	35 x 27 x 7,5 EN 60715	98.300.0000.0	1
35 x 27 x 15 EN 60715	98.360.0000.0	1	35 x 27 x 15 EN 60715	98.360.0000.0	1	35 x 27 x 15 EN 60715	98.360.0000.0	1
9708/2 S35	Z5.522.8553.0	100	9708/2 S35	Z5.522.8553.0	100	9708/2 S35	Z5.522.8553.0	100
WEF 1/35	Z5.523.9353.0	100						
API 10-16 SL	07.311.9555.0	10	API 10-16 SL	07.311.9555.0	10			
AD VB 10 GELB	04.326.2353.8	10	AD VB 16 GELB	04.326.2453.8	10	AD VB 10 GELB	04.326.2353.8	10
AD 10/1 GELB	04.325.8553.8	10	AD 16/1 GELB	04.325.8653.8	10	AD 35/1 GELB	04.325.8753.8	10

PEN assembly block with screw connection for junction boxes, type WKI...

selos BITOS

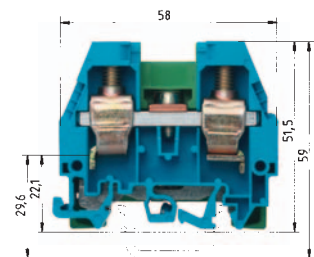
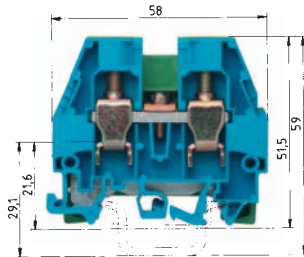

WKI 10 PEN/35

	fine-stranded	solid/stranded	V	A
	1 – 10 mm ²	1.5 – 16 mm ²	400 V/6 kV/3	57
No. 16-6 AWG			600 V	65/65
No. 16-6 AWG			600 V	70
Width	20 mm		18 mm	
Wire strip length	20 mm			

WKI 16 PEN/35

	fine-stranded	solid/stranded	V	A
	1 – 16 mm ²	1.5 – 25 mm ²	400 V/6 kV/3	76
No. 12-4 AWG			600 V	65/65
No. 14-4 AWG			600 V	95
Width	24 mm		16 mm	
Wire strip length	24 mm			

EN 60 947-7-1, EN 60 947-7-2

UL ratings

CSA ratings

Width

Approvals

Wire strip length

PEN assembly block		Type	Part No.	Std. Pack	Type	Part No.	Std. Pack
green/yellow – blue		WKI 10 PEN/35	56.510.9455.0	20	WKI 16 PEN/35	56.516.9455.0	20
Accessories							
1. Mounting rail TS 35, DIN rail 7.5 mm high	L = 2 m	35 x 27 x 7,5 EN 60715	98.300.0000.0	1	35 x 27 x 7,5 EN 60715	98.300.0000.0	1
Mounting rail TS 35, DIN rail 15 mm high	L = 2 m	35 x 27 x 15 EN 60715	98.360.0000.0	1	35 x 27 x 15 EN 60715	98.360.0000.0	1
2. End clamp for TS 35, with screw	8 mm wide	9708/2 S35	Z5.522.8553.0	100	9708/2 S35	Z5.522.8553.0	100
End clamp for TS 35, without screws	8 mm wide	WEF 1/35	Z5.523.9353.0	100			
3. End plate	1.5 mm thick						
	1.5 mm thick	API 10-16 BLAU	07.311.9455.6	10	API 10-16 BLAU	07.311.9455.6	10
	1.5 mm thick						
End plate	2 mm thick						
	2 mm thick						
	2 mm thick						
4. Partition plate	gray						
	blue						
5. Cross connector with screws (jumper bar)	2 pole						
insulated	3 pole						
	4 pole						
	5 pole						
	6 pole						
6. Partition plate with marking facility	yellow	TS 10 GELB	07.311.2353.8	10	TS 16 GELB	07.311.2453.8	10
7. Cover with marking facility	yellow	AD VB 10 GELB	04.326.2353.8	10	AD VB 16 GELB	04.326.2453.8	10
8. Cover with warning symbol over 4 blocks	yellow						
Cover with warning symbol for 1 block	yellow	ADI 10/1 GELB	04.325.8553.8	10	AD 16/1 GELB	04.325.8653.8	10
9. Busbar							
	E-Cu 10 x 3 mm, tin-plated, I _N = 140	L = 1 m					
	E-Cu 10 x 3 mm, unplated, I _N = 140 A	L = 1 m					
10. Connector clamp for busbar							
	16 mm ²	8.5 mm wide					
	35 mm ²	17 mm wide					
11. Busbar support	4 mm wide						
Busbar support	8 mm wide						
Marking accessories see page 230-237							

PEN assembly block with screw connection for junction boxes, type WKI...

setos

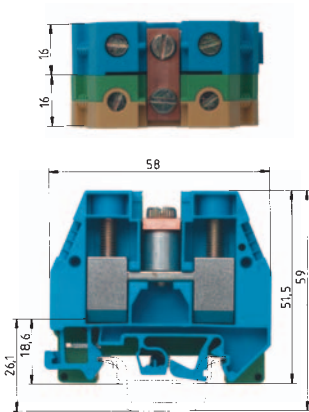

WKI 35 PEN/35

	fine-stranded	stranded	V	A
	16 – 35 mm ²	16 – 50 mm ²	400 V/6 kV/3	125
No. 10-2 AWG			600 V	95/95
No. 10-2 AWG			600 V	110
32 mm				13 mm

Type	Part No.	Std. Pack
WKI 35 PEN/35	56.535.9455.0	10
35 x 27 x 7,5 EN 60715	98.300.0000.0	1
35 x 27 x 15 EN 60715	98.360.0000.0	1
9708/2 S35	Z5.522.8553.0	100
API 35 BLAU	07.311.8855.6	10
TS 35 GELB	07.311.8653.8	10
AD 35/1 GELB	04.325.8753.8	10

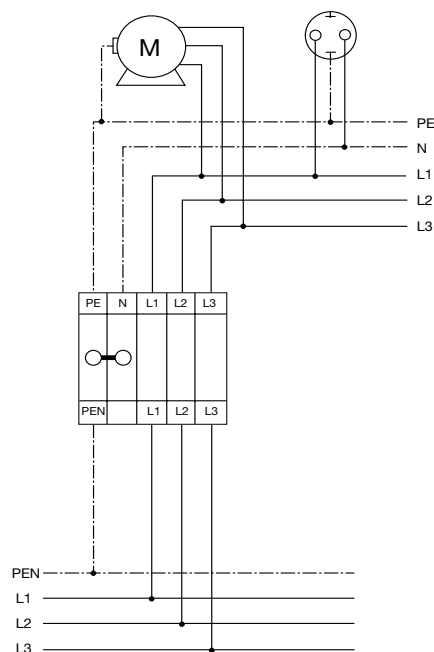

PEN assembly block for junction box IEC 947-7-2 EN 60947-7-2

Electrical power is often supplied to the plant in a 4 conductor three phase system (L1, L2, L3, and Ground). However, the electrical equipment in the plant may require a 5 conductor three phase system (L1, L2, L3, N, and Ground). Therefore, it is important to have a connection system to accommodate both possibilities.

The Wieland **WKI ... PEN/35** system accomplishes this task. The PEN assembly terminal block consists of a ground terminal which is grounded to the DIN rail and a neutral terminal (color coded blue) which is electrically isolated from the DIN rail. The two terminals are commoned via a cross connector (jumper bar) thereby, tying the neutral terminal to ground.

When using the PEN assembly terminal block system, the DIN mounting rail only acts as a grounding bus. Therefore, copper mounting rail is not required and standard zinc plated steel DIN can be used for grounding purposes.

These assemblies have the same symmetry as the corresponding feed-through terminals of the WKI series and fit the height required for junction boxes per DIN 43871 when using DIN rail size 35 x 27 x 7.5.