

# 30 Series - Subminiature D.I.L. Relays 1.25 A

30

- Low level switching capability
- Sensitive DC coil, 200mW
- Relay technology: RT III

## 30.22



- Low consumption
- P.C.B. mounting

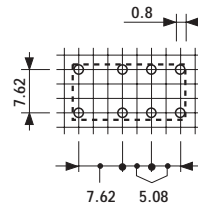
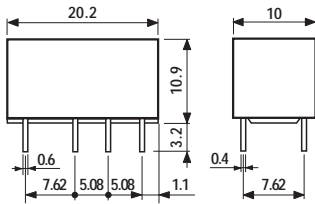
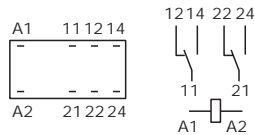

Copper side view

Contact specifications		
Contact configuration		2 CO
Rated current/Maximum peak current	A	1.25/2
Rated voltage/Maximum switching voltage V AC		125/250
Rated load in AC1	VA	125
Rated load in AC15 (230 VAC)	VA	25
Single phase motor rating (230 VAC)	kW	—
Breaking capacity in DC1: 30/110/220V	A	2/0.3/—
Minimum switching load	mW (V/mA)	10 (0.1/1)
Standard contact material		AgNi+Au
Coil specifications		
Nominal voltage (U <sub>N</sub> )	V AC (50/60 Hz)	—
	V DC	5 - 6 - 9 - 12 - 24 - 48
Rated power AC/DC	VA (50 Hz)/W	—/0.2
Operating range	AC (50 Hz)	—
	DC	see table page 5
Holding voltage	AC/DC	—/0.35 U <sub>N</sub>
Must drop-out voltage	AC/DC	—/0.05 U <sub>N</sub>
Technical data		
Mechanical life AC/DC	cycles	—/10 · 10 <sup>6</sup>
Electrical life at rated load AC1	cycles	100 · 10 <sup>3</sup>
Operate/release time (bounce included)	ms	15/10
Insulation according to EN 61810-5		1.2 kV/2
Insulation between coil and contacts (1.2/50µs)	kV	1.5
Dielectric strength between open contacts V AC		750
Ambient temperature range	°C	-40...+85
Environmental protection		RT III
<b>Approvals:</b> (according to type)		—

## ORDERING INFORMATION

Example: a 30 series P.C.B. relay with 2 CO contacts, with coil rated at 12 V sensitive DC.

3	0	.	2	.	2	.	7	.	0	1	2	.	0	0	.	1	0
---	---	---	---	---	---	---	---	---	---	---	---	---	---	---	---	---	---

**A:** Contact material  
0 = Standard  
AgNi + Au (5µm)

**B:** Contact circuit  
0 = CO

**C:** Options  
1 = None

**D:** Special versions  
0 = Wash tight (RT III)

**Series** ————

**Type** ————  
2 = P.C.B.

**No. of poles** ————  
2 = 2 pole, 1.25 A

**Coil version** ————  
7 = Sensitive DC

**Coil voltage** ————  
see coil specifications

## TECHNICAL DATA

### INSULATION

INSULATION according to EN 61810-5	insulation rated voltage	V	125
	rated impulse withstand voltage	kV	1.2
	pollution degree		2
	overvoltage category		I

### OTHER DATA

VIBRATION RESISTANCE (10...55Hz): NO/NC	g/g	10/10
POWER LOST TO THE ENVIRONMENT	without contact current	W
	with rated current	W
RECOMMENDED DISTANCE between RELAYS mounted on P.C.B.s	mm	≥5

## COIL SPECIFICATIONS

### DC VERSION DATA (0.2 W sensitive)

Nominal voltage $U_N$	Coil code	Operating range		Resistance $R$	Rated coil consumption $I$ at $U_N$
		$U_{min}$	$U_{max}$		
V		V	V	$\Omega$	mA
5	7.005	3.7	7.5	125	40
6	7.006	4.5	9	180	33
9	7.009	6.7	13.5	405	22
12	7.012	8.4	18	720	16
24	7.024	16.8	36	2880	8.3
48	7.048	36	72	11520	4.1

### R 30 DC

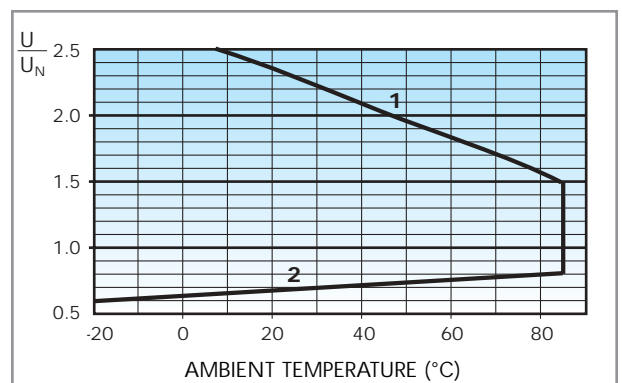

Operating range vs ambient temperature.

**1** - Max coil voltage permitted.

**2** - Min pick-up voltage with coil at ambient temperature.

**34**

- Ultra-slim, 5 mm wide
- Sensitive DC coil, 170mW
- 6/8 mm distance/creepage
- 6kV (1.2/50 μs) between coil and contacts

### 34.51



- 5 mm wide
- P.C.B. mounting

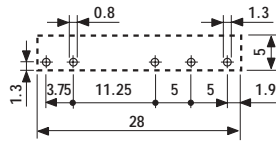
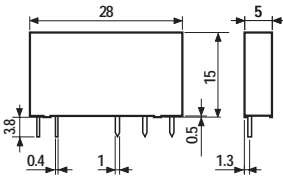
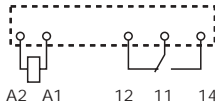

Copper side view

\* for 400 V applications, requirements for pollution degree 2 are met.

Contact specifications		
Contact configuration		1 CO
Rated current/Maximum peak current	A	6/10
Rated voltage/Maximum switching voltage	V AC	250/400*
Rated load in AC1	VA	1,500
Rated load in AC15 (230 VAC)	VA	300
Single phase motor rating (230 VAC)	kW	—
Breaking capacity in DC1: 30/110/220V	A	6/0.2/0.12
Minimum switching load	mW (V/mA)	500 (12/10)
Standard contact material		AgNi
Coil specifications		
Nominal voltage (U <sub>N</sub> )	V AC (50/60 Hz)	—
	V DC	5 · 12 · 24 · 48 · 60
Rated power AC/DC	VA (50 Hz)/W	—/0.17
Operating range	AC (50 Hz)	—
	DC	(0.7 ... 1.5)U <sub>N</sub>
Holding voltage	AC/DC	—/0.4 U <sub>N</sub>
Must drop-out voltage	AC/DC	—/0.05 U <sub>N</sub>
Technical data		
Mechanical life AC/DC	cycles	—/10 · 10 <sup>6</sup>
Electrical life at rated load AC1	cycles	60 · 10 <sup>3</sup>
Operate/release time (bounce included)	ms	7/8
Insulation according to EN 61810-5		4 kV/3
Insulation between coil and contacts (1.2/50μs)	kV	6 (8 mm)
Dielectric strength between open contacts	V AC	1,000
Ambient temperature range	°C	-40...+85
Environmental protection		RT II
<b>Approvals:</b> (according to type)		GOST

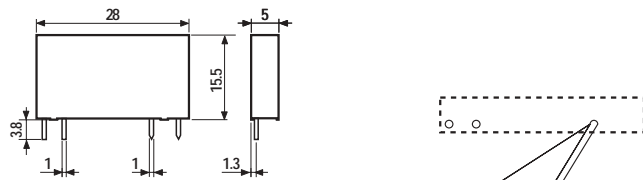

## ORDERING INFORMATION

### 34 ELECTROMECHANICAL RELAY

Example: a 34 series slim electromechanical relay, 1 CO - 6 A, with 24 V sensitive DC coil.

	<b>3</b>	<b>4</b>	.	<b>5</b>	.	<b>1</b>	.	<b>7</b>	.	<b>0</b>	<b>2</b>	<b>4</b>	.	<b>A</b>	<b>B</b>	<b>C</b>	<b>D</b>	
<b>Series</b>	_____			_____			_____			_____			_____		_____		_____	
<b>Type</b>	_____			_____			_____			_____			_____		_____		_____	
5 = Electromechanical type																		
<b>No. of poles</b>	_____			_____			_____			_____			_____		_____		_____	
1 = 1 pole, 6 A																		
<b>Coil version</b>	_____			_____			_____			_____			_____		_____		_____	
7 = Sensitive DC																		
<b>Coil voltage</b>	_____			_____			_____			_____			_____		_____		_____	
see coil specifications																		

<b>A: Contact material</b>	0 = Standard AgNi
	4 = AgSnO <sub>2</sub>
	5 = AgNi + Au
<b>B: Contact circuit</b>	0 = CO
<b>D: Special versions</b>	0 = Flux proof (RT II)
<b>C: Options</b>	1 = None

### SOLID STATE RELAY

Example: a 34 series SSR relay, 2 A, with 24 V DC supply.

	<b>3</b>	<b>4</b>	.	<b>8</b>	.	<b>1</b>	.	<b>7</b>	.	<b>0</b>	<b>2</b>	<b>4</b>	.	<b>9</b>	<b>0</b>	<b>2</b>	<b>4</b>	
<b>Series</b>	_____			_____			_____			_____			_____		_____		_____	
<b>Type</b>	_____			_____			_____			_____			_____		_____		_____	
8 = SSR type																		
<b>Output</b>	_____			_____			_____			_____			_____		_____		_____	
1 = 1 NO																		
<b>Input circuit</b>	_____			_____			_____			_____			_____		_____		_____	
see input specifications																		

<b>Output circuit</b>	9024 = 2 A - 24 VDC
	7048 = 100 mA - 48 VDC

## SOLID STATE RELAY

### OTHER DATA

POWER LOST TO THE ENVIRONMENT	without contact current	W	0.17
	with rated current	W	0.4

## INPUT SPECIFICATION

### DC VERSION DATA

Nominal voltage U <sub>N</sub>	Input code	Operating range		Release voltage	Control current I at U <sub>N</sub>
		U <sub>min</sub>	U <sub>max</sub>		
V		V	V	V	mA
24	7.024	16	30	10	7
60	7.060	35	72	20	3

## ELECTROMECHANICAL RELAY

### TECHNICAL DATA

34

#### INSULATION

INSULATION according to EN 61810-5	insulation rated voltage	V	250
	rated impulse withstand voltage	kV	4
	pollution degree		3
	overvoltage category		III

#### IMMUNITY

CONDUCTED DISTURBANCE IMMUNITY	BURST (according to EN 61000-4-4)	level 4 (4 kV)
	SURGE (according to EN 61000-4-5)	level 3 (2 kV)

#### OTHER DATA

VIBRATION RESISTANCE (10...55Hz): NO/NC	g/g	10/5	
POWER LOST TO THE ENVIRONMENT	without contact current	W	0.2
	with rated current	W	0.5
RECOMMENDED DISTANCE between RELAYS mounted on P.C.B.s	mm	≥5	

## CONTACT SPECIFICATIONS

### F 34

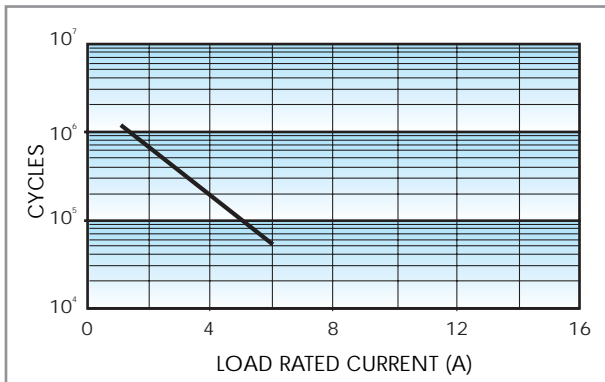

Electrical life vs AC1 load.

### H 34

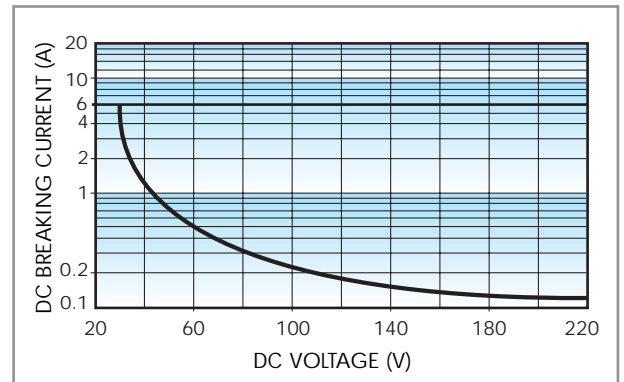

Breaking capacity in DC1 load.

- When switching a resistive load (DC1) having voltage and current values under the curve the expected electrical life is  $\geq 100 \cdot 10^3$  cycles.
  - In case of DC13 loads the connection of a diode in parallel with the load will permit the same electrical life as for a DC1 load.
- Note:** the release time of load will be increase.

## COIL SPECIFICATIONS

#### DC VERSION DATA

Nominal voltage $U_N$ V	Coil code	Operating range		Resistance R $\Omega$	Rated coil consumption I at $U_N$ mA
		$U_{min}$ V	$U_{max}$ V		
5	7.005	3.5	7.5	130	38.4
12	7.012	8.4	18	840	14.2
24	7.024	16.8	36	3,350	7.1
48	7.048	33.6	72	12,300	3.9
60	7.060	42	90	19,700	3

### R 34 DC

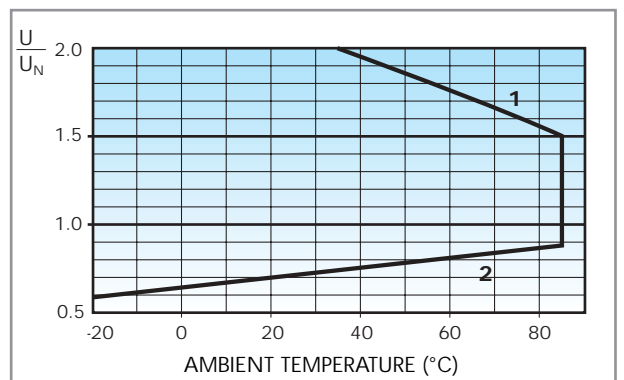

Operating range vs ambient temperature.





- 1 - Max coil voltage permitted.
- 2 - Min pick-up voltage with coil at ambient temperature.

- P.C.B. mount
- Sugar cube
- DC coil
- Sealed

36

### 36.11

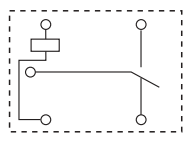
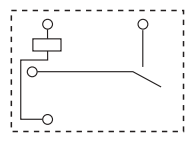
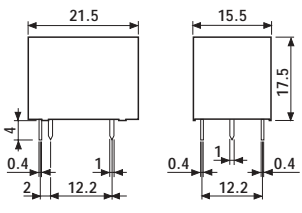
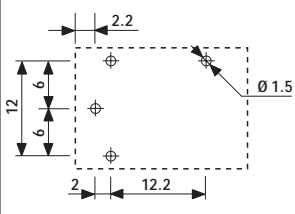
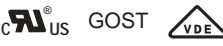
### 36.11...0300

		
	- Sugar cube - 1 CO - P.C.B. mounting	- Sugar cube - 1 NO - P.C.B. mounting
		
		
	Copper side view	Copper side view
<b>Contact specifications</b>		
Contact configuration	1 CO	1 NO
Rated current/Maximum peak current	A 10/15	A 10/15
Rated voltage/Maximum switching voltage	V AC 250/250	V AC 250/250
Rated load in AC1	VA 2,500	VA 2,500
Rated load in AC15 (230 VAC)	VA 500	VA 500
Single phase motor rating (230 VAC)	kW 0.37	kW 0.37
Breaking capacity in DC1: 30/110/220V	A 10/0.2/0.12	A 10/0.2/0.12
Minimum switching load	mW (V/mA) 500 (5/100)	mW (V/mA) 500 (5/100)
Standard contact material	AgCdO	AgCdO
<b>Coil specifications</b>		
Nominal voltage (U <sub>N</sub> )	V AC (50/60 Hz) — V DC 3 · 5 · 6 · 9 · 12 · 24 · 48	V AC (50/60 Hz) — V DC 3 · 5 · 6 · 9 · 12 · 24 · 48
Rated power AC/sens. DC	VA (50 Hz)/W —/0.36	VA (50 Hz)/W —/0.36
Operating range	AC (50 Hz) — DC (0.75...1.5)U <sub>N</sub>	AC (50 Hz) — DC (0.75...1.5)U <sub>N</sub>
Holding voltage	AC/DC —/0.4 U <sub>N</sub>	AC/DC —/0.4 U <sub>N</sub>
Must drop-out voltage	AC/DC —/0.1 U <sub>N</sub>	AC/DC —/0.1 U <sub>N</sub>
<b>Technical data</b>		
Mechanical life AC/DC	cycles —/10 · 10 <sup>6</sup>	cycles —/10 · 10 <sup>6</sup>
Electrical life at rated load AC1	cycles 100 · 10 <sup>3</sup>	cycles 100 · 10 <sup>3</sup>
Operate/release time (bounce included)	ms 10/5	ms 10/5
Insulation according to EN 61810-5	2.5 kV/2	2.5 kV/2
Insulation between coil and contacts (1.2/50µs)	kV 4	kV 4
Dielectric strength between open contacts	V AC 1,000	V AC 1,000
Ambient temperature range	°C -40...+85	°C -40...+85
Environmental protection	RT III	RT III
<b>Approvals:</b> (according to type)		



## ORDERING INFORMATION

Example: a 36 series miniature P.C.B. relay, 1 CO - 10 A contacts, with 12 V DC coil.

<b>3</b>	<b>6</b>	<b>1</b>	<b>1</b>	<b>9</b>	<b>0</b>	<b>1</b>	<b>2</b>	<b>A</b>	<b>B</b>	<b>C</b>	<b>D</b>
<b>Series</b>		<b>Type</b>		<b>No. of poles</b>		<b>Coil version</b>		<b>A: Contact material</b>		<b>D: Special versions</b>	
1 = P.C.B.		1 = P.C.B.		1 = 1 pole, 10 A		9 = DC		0 = Standard AgCdO		0 = Wash tight (RT III)	
<b>Coil voltage</b>		<b>Coil version</b>		<b>Coil voltage</b>		<b>Coil version</b>		<b>B: Contact circuit</b>		<b>C: Options</b>	
see coil specifications		9 = DC		see coil specifications		9 = DC		0 = CO 3 = NO		0 = None	

## TECHNICAL DATA

### INSULATION

INSULATION according to EN 61810-5	insulation rated voltage	V	250
	rated impulse withstand voltage	kV	2.5
	pollution degree		2
	overvoltage category		II

## CONTACT SPECIFICATIONS

### F 36

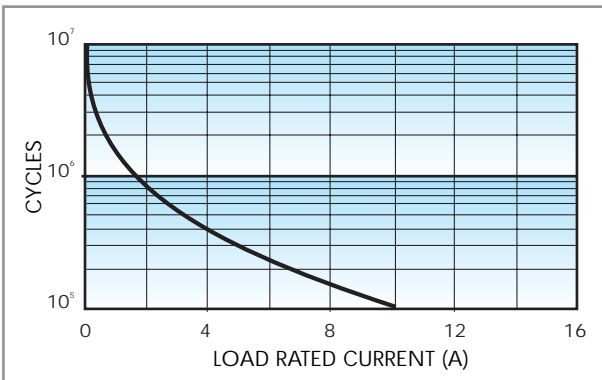

Electrical life vs AC1 load.

### H 36

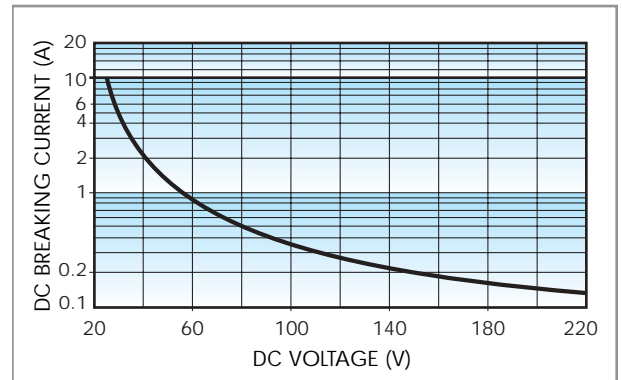

Breaking capacity in DC1 load.

- When switching a resistive load (DC1) having voltage and current values under the curve the expected electrical life is  $\geq 100 \cdot 10^3$  cycles.
  - In case of DC13 loads the connection of a diode in parallel with the load will permit the same electrical life as for a DC1 load.
- Note:** the release time of load will be increase.

## COIL SPECIFICATIONS

### DC VERSION DATA

Nominal voltage $U_N$ V	Coil code	Operating range		Resistance R $\Omega$	Rated coil consumption I at $U_N$ mA
		$U_{min}$ V	$U_{max}$ V		
3	9.003	2.2	4.5	25	120
5	9.005	3.7	7.5	70	72
6	9.006	4.5	9	100	60
9	9.009	6.7	13.5	225	40
12	9.012	9	18	400	30
24	9.024	18	36	1,600	15
48	9.048	36	72	6,400	7.5

### R 36

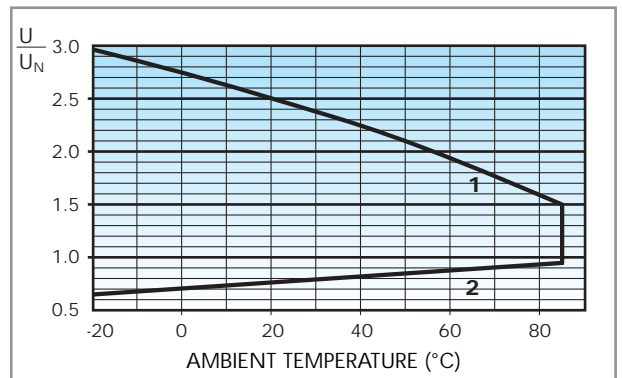

Operating range vs ambient temperature.

- 1 - Max coil voltage permitted.
- 2 - Min pick-up voltage with coil at ambient temperature.

- P.C.B. or plug-in mount
- AC, DC, sensitive DC or single bistable coil versions available
- 8 mm, 6 kV (1.2/50 μs) between coil and contacts
- Ambient temperature +85°C
- Sockets and accessories: see 95, 99 and 86 series
- RT III (wash tight) version available

40

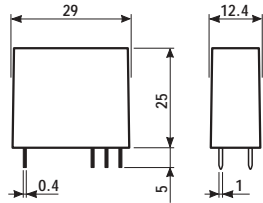

\* for 400 V applications, requirements for pollution degree 2 are met.

### 40.31

### 40.51

### 40.52



- 1 pole, 10 A
- 3.5 mm pinning
- P.C.B. / for use with 95 series sockets

- 1 pole, 10 A
- 5 mm pinning
- P.C.B. / for use with 95 series sockets

- 2 pole, 8 A
- 5 mm pinning
- P.C.B. / for use with 95 series sockets

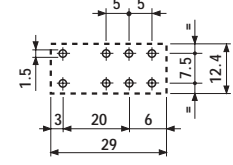
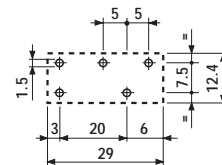
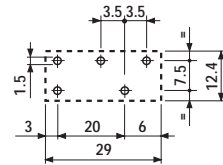
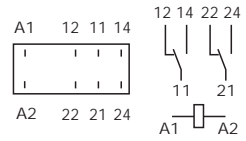
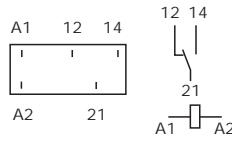
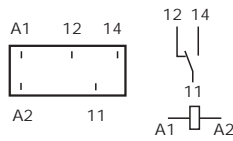

Copper side view

Copper side view

Copper side view

Contact specifications				
Contact configuration		1 CO	1 CO	2 CO
Rated current/Maximum peak current	A	10/20	10/20	8/15
Rated voltage/Maximum switching voltage	V AC	250/400*	250/400*	250/250
Rated load in AC1	VA	2,500	2,500	2,000
Rated load in AC15 (230 VAC)	VA	500	500	400
Single phase motor rating (230 VAC)	kW	0.37	0.37	0.3
Breaking capacity in DC1: 30/110/220V	A	10/0.3/0.12	10/0.3/0.12	8/0.3/0.12
Minimum switching load	mW (V/mA)	300 (5/5)	300 (5/5)	300 (5/5)
Standard contact material		AgNi	AgNi	AgNi
Coil specifications				
Nominal voltage (U <sub>N</sub> )	V AC (50/60 Hz)	6 · 12 · 24 · 48 · 60 · 110 · 120 · 230 · 240		
	V DC	5 · 6 · 7 · 9 · 12 · 14 · 18 · 21 · 24 · 28 · 36 · 48 · 60 · 90 · 110		
Rated power AC/DC/sens. DC	VA (50 Hz)/W/W	1.2/0.65/0.5	1.2/0.65/0.5	1.2/0.65/0.5
Operating range	AC (50 Hz)	(0.8...1.1)U <sub>N</sub>		
	DC/sens. DC	(0.73...1.5)U <sub>N</sub> /(0.73...1.75)U <sub>N</sub>		
Holding voltage	AC/DC	0.8 U <sub>N</sub> / 0.4 U <sub>N</sub>		
Must drop-out voltage	AC/DC	0.2 U <sub>N</sub> / 0.1 U <sub>N</sub>		
Technical data				
Mechanical life AC/DC	cycles	10 · 10 <sup>6</sup> /20 · 10 <sup>6</sup>		
Electrical life at rated load AC1	cycles	200 · 10 <sup>3</sup>		
Operate/release time (bounce included)	ms	10/10 · (15/12 sens.)		
Insulation according to EN 61810-5		3.6 kV/3		
Insulation between coil and contacts (1.2/50μs)	kV	6 (8mm)		
Dielectric strength between open contacts	V AC	1,000		
Ambient temperature range	°C	-40...+85		
Environmental protection		RT I		

**Approvals:** (according to type)



- P.C.B. or plug-in mount
- AC, DC, sensitive DC or single bistable coil versions available
- 8 mm, 6 kV (1.2/50 μs) between coil and contacts
- Ambient temperature +85°C
- Sockets and accessories: see 95, 99 and 86 series
- RT III (wash tight) version available

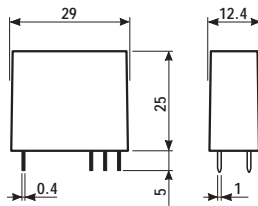

- \* for 400 V applications, requirements for pollution degree 2 are met.
- \*\* with the AgSnO<sub>2</sub> material the maximum peak current is 100 A · 5 ms.

	40.61	40.xx.6
	<ul style="list-style-type: none"> <li>- 1 pole, 16 A</li> <li>- 5 mm pinning</li> <li>- P.C.B. / for use with 95 series sockets</li> </ul>	<ul style="list-style-type: none"> <li>- Bistable version (1 coil)</li> <li>- P.C.B. / for use with 95 series sockets</li> </ul>
	<p style="text-align: center;">Copper side view</p>	<p>Bistable version (1 coil) types:</p> <p style="text-align: center;">40.31.6... 40.51.6... 40.52.6... 40.61.6...</p> <p style="text-align: center;">For wiring diagrams see page 16</p> <p style="text-align: center;">Copper side view</p>
<b>Contact specifications</b>		
Contact configuration	1 CO	
Rated current/Maximum peak current      A	16/30**	
Rated voltage/Maximum switching voltage V AC	250/400*	See relays
Rated load in AC1                              VA	4,000	40.31
Rated load in AC15 (230 VAC)              VA	750	40.51
Single phase motor rating (230 VAC)      kW	0.55	40.52
Breaking capacity in DC1: 30/110/220V    A	16/0.3/0.12	40.61
Minimum switching load                      mW (V/mA)	500 (10/5)	
Standard contact material	AgCdO	
<b>Coil specifications</b>		
Nominal voltage (U <sub>N</sub> )                      V AC (50/60 Hz)	6 · 12 · 24 · 48 · 60 · 110 · 120 · 230 · 240	5 · 6 · 12 · 24 · 48 · 110
	V DC	***See below
Rated power AC/DC/sens. DC              VA (50 Hz)/W/W	1.2/0.65/0.5	1.0/1.0/—
Operating range                              AC (50 Hz)	(0.8...1.1)U <sub>N</sub>	(0.8...1.1)U <sub>N</sub>
	DC/sens. DC	(0.73...1.5)U <sub>N</sub> /(0.8...1.5)U <sub>N</sub>
Holding voltage                              AC/DC	0.8 U <sub>N</sub> /0.4 U <sub>N</sub>	—
Must drop-out voltage                      AC/DC	0.2 U <sub>N</sub> /0.1 U <sub>N</sub>	—
<b>Technical data</b>		
Mechanical life AC/DC                      cycles	10 · 10 <sup>6</sup> /20 · 10 <sup>6</sup>	See relays
Electrical life at rated load AC1           cycles	100 · 10 <sup>3</sup>	40.31
Operate/release time (bounce included)   ms	10/10 · (15/12 sens.)	40.51
Insulation according to EN 61810-5	3.6 kV/3	40.52
Insulation between coil and contacts (1.2/50μs) kV	6 (8mm)	40.61
Dielectric strength between open contacts V AC	1,000	
Ambient temperature range                °C	-40...+85	Min. impulse duration ≥ 20 ms
Environmental protection	RT I	
<b>Approvals:</b> (according to type)		

\*\*\* Nominal voltage (U<sub>N</sub>):  
5 · 6 · 7 · 9 · 12 · 14 · 18 · 21 ·  
24 · 28 · 36 · 48 · 60 · 90 ·  
110 V DC



## CONTACT SPECIFICATIONS

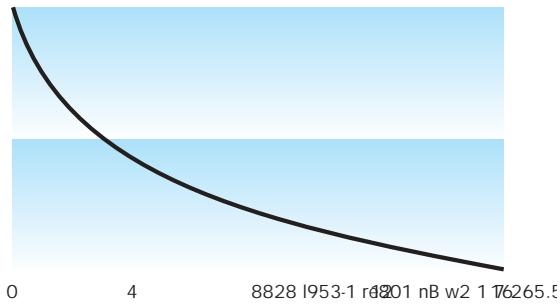

Electrical life vs AC1 load.

- 1** - Type 40.52 (8 A)
- 2** - Type 40.31 - 40.51 (10 A)
- Type 40.61 (16 A)

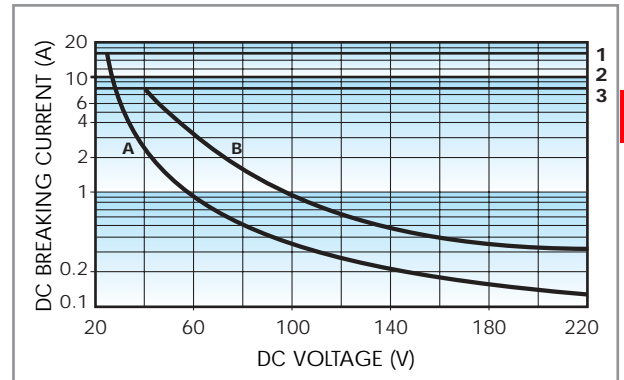

Breaking capacity for DC1 load.

- 1** - Type 40.61
- 2** - Type 40.31 - 40.51
- 3** - Type 40.52
- A** - Load applied to 1 contact
- B** - Load applied to 2 contacts in series

- When switching a resistive load (DC1) having voltage and current values under the curve the expected electrical life is  $\geq 100 \cdot 10^3$  cycles.
  - In case of DC13 loads the connection of a diode in parallel with the load will permit the same electrical life as for a DC1 load.
- Note:** the release time of load will be increase.

## COIL SPECIFICATIONS

### R 40 DC

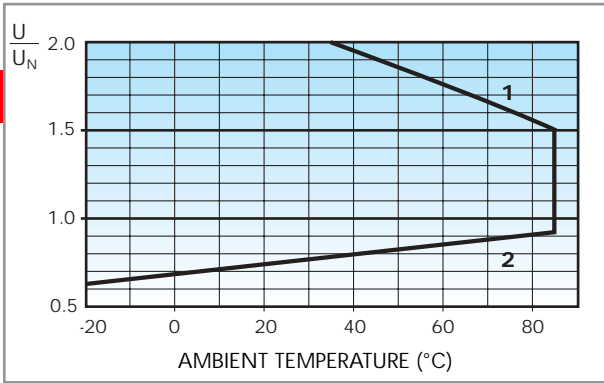

### R 40 sens. DC

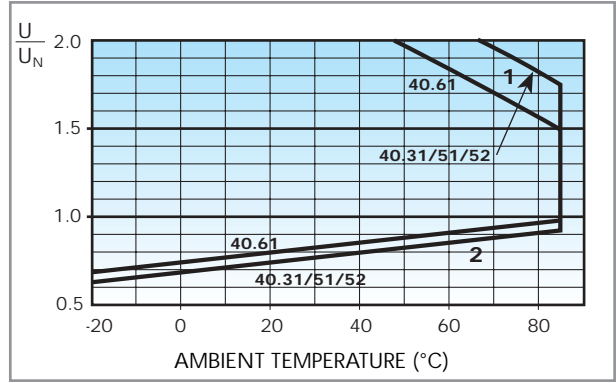

### R 40 AC

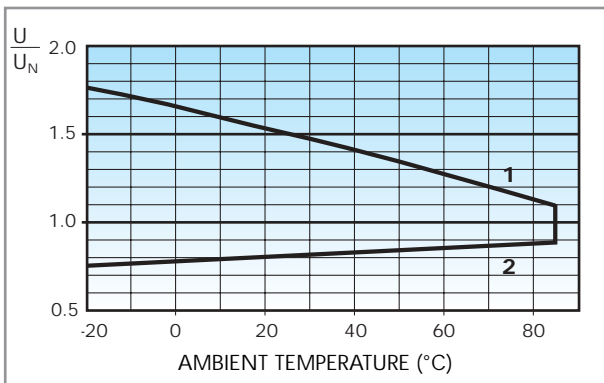

Operating range vs ambient temperature.

- 1 - Max coil voltage permitted.
- 2 - Min pick-up voltage with coil at ambient temperature.

### Wiring Diagram for 40 Series bistable coil version

#### AC Operation

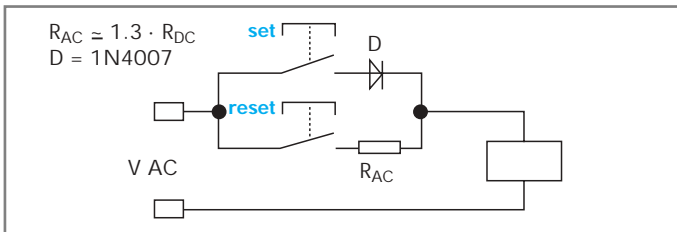

#### DC Operation

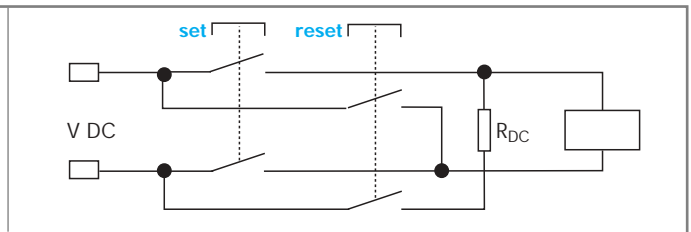

On momentary closure of the SET switch the relay is magnetised through the diode and the relay contacts transfer to the set position and remain in this position.

On momentary closure of the RESET switch the relay is demagnetised through limiting resistor ( $R_{AC}$ ) and the contacts return to the reset position.

On momentary closure of the SET switch the relay is magnetised and the relay contacts transfer to the set position and remain in this position. On momentary closure of the RESET switch the relay is demagnetised through limiting resistor ( $R_{DC}$ ) and the contacts return to the reset position.

**Notes:** The minimum SET or RESET impulse time is 20 ms. The maximum time can be continuous. In practice, always ensure that the SET and RESET contacts cannot be operated simultaneously.



95.05

Approvals  
(according to type):



095.01

- RATED VALUES: 10 A - 250 V  
*with a current >10 A, the contact terminal must be connected in parallel (21 with 11, 24 with 14, 22 with 12)*
- INSULATION:  $\geq 6$  kV (1.2/50 $\mu$ s) between coil and contacts
- PROTECTION CATEGORY: IP 20
- AMBIENT TEMPERATURE: (-40...+70) °C
- SCREW TORQUE: 0.5 Nm
- WIRE STRIP LENGTH: 8 mm
- MAX WIRE SIZE:

	solid wire	stranded wire
mm <sup>2</sup>	1x6 / 2x2.5	1x4 / 2x2.5
AWG	1x10 / 2x14	1x12 / 2x14

Relay type	40.31		40.51, 40.52, 40.61	
	BLUE	BLACK	BLUE	BLACK
Colour	BLUE	BLACK	BLUE	BLACK
<b>Clamp terminal socket:</b> panel or 35 mm rail (EN 50022) mount, retaining clip 095.01 supplied with socket packaging code SPA	95.03	95.03.0	95.05	95.05.0
Plastic retaining and release clip	095.01	095.01.0	095.01	095.01.0
Metal retaining clip	095.71			
8-way jumper link for 95.03 and 95.05 sockets	095.18	095.18.0	095.18	095.18.0
Identification tag	095.00.4			
Modules (see table below)	99.02			
Timer modules	86.10, 86.20			

40

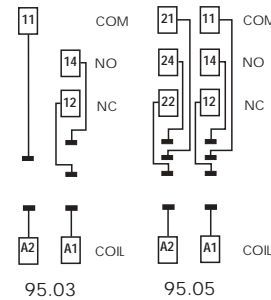
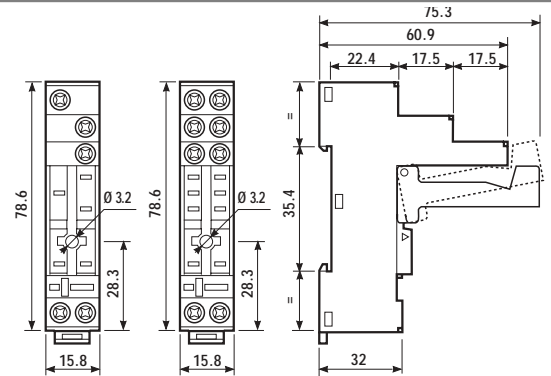

095.18

- RATED VALUES: 10 A - 250 V

<b>8-way jumper link</b> for 95.03, and 95.05 sockets	095.18
---	--------

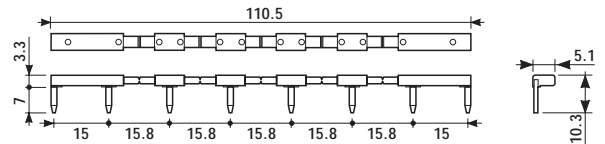

99.02

99.02 modules for 95.03 and 95.05 sockets		BLUE
Diode** (+A1)	(6...220) V DC	99.02.3.000.00
LED	(6...24) V DC/AC	99.02.0.024.59
LED	(28...60) V DC/AC	99.02.0.060.59
LED	(110...240) V DC/AC	99.02.0.230.59
LED + Diode** (+A1)	(6...24) V DC	99.02.9.024.99
LED + Diode** (+A1)	(28...60) V DC	99.02.9.060.99
LED + Diode** (+A1)	(110...220) V DC	99.02.9.220.99
LED + Varistor	(6...24) V DC/AC	99.02.0.024.98
LED + Varistor	(28...60) V DC/AC	99.02.0.060.98
LED + Varistor	(110...240) V DC/AC	99.02.0.230.98
RC	(6...24) V DC/AC	99.02.0.024.09
RC	(28...60) V DC/AC	99.02.0.060.09
RC	(110...240) V DC/AC	99.02.0.230.09
Residual current bypass (62 k $\Omega$ /1W)	(110...240) V AC	99.02.8.230.07

\*\*For DC supply, apply the positive to terminal A1. Modules in Black housing are available on request.

40



95.63



95.65



95.75

Approvals  
(according to type):



- RATED VALUES: 10 A · 250 V  
with a current > 10 A, the contact terminal must be connected in parallel (21 with 11, 24 with 14, 22 with 12)
- INSULATION: ≥ 6 kV (1.2/50µs)  
between coil and contacts  
(Types 95.63/75 only)
- PROTECTION CATEGORY: IP 20
- AMBIENT TEMPERATURE: (-40...+70) °C
- SCREW TORQUE: 0.5 Nm
- WIRE STRIP LENGTH: 7 mm
- MAX WIRE SIZE:

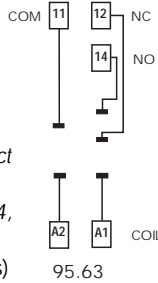
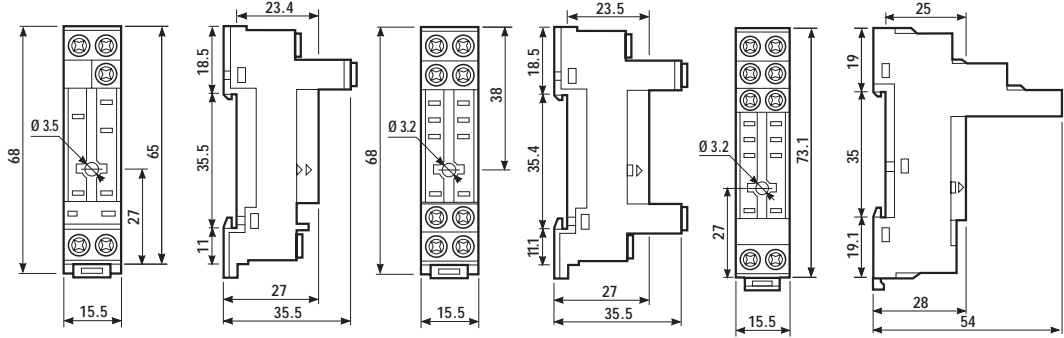

95.63

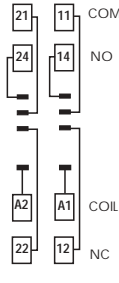

95.65

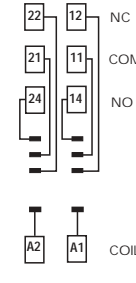

95.75

Relay type	40.31		40.51, 40.52, 40.61			
Colour	BLUE	BLACK	BLUE	BLACK	BLUE	BLACK
Clamp terminal socket: panel or 35 mm rail (EN 50022) mount retaining clip 095.71 supplied with socket packaging code SMA	95.63	95.63.0	95.65	95.65.0	95.75	95.75.0
Metal retaining clip	095.71					
8-way jumper link for 95.63 and 95.75 sockets	095.08	095.08.0	095.08	095.08.0	095.08	095.08.0
Modules (see table below)	99.01		—		99.01	



095.08

- RATED VALUES: 10 A · 250 V

<b>8-way jumper link</b> for 95.63, 95.65 and 95.75 sockets	095.08
---	--------

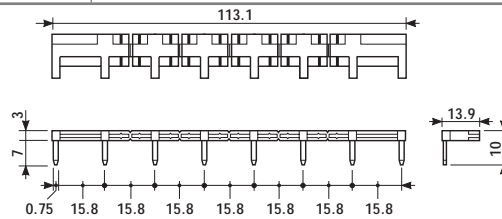

99.01

99.01 modules for 95.63 and 95.75 sockets		BLUE
Diode** (+A1)	(6...220) V DC	99.01.3.000.00
LED	(6...24) V DC/AC	99.01.0.024.59
LED	(28...60) V DC/AC	99.01.0.060.59
LED	(110...240) V DC/AC	99.01.0.230.59
LED + Diode** (+A1)	(6...24) V DC	99.01.9.024.99
LED + Diode** (+A1)	(28...60) V DC	99.01.9.060.99
LED + Diode** (+A1)	(110...220) V DC	99.01.9.220.99
LED + Varistor	(6...24) V DC/AC	99.01.0.024.98
LED + Varistor	(28...60) V DC/AC	99.01.0.060.98
LED + Varistor	(110...240) V DC/AC	99.01.0.230.98
RC	(6...24) V DC/AC	99.01.0.024.09
RC	(28...60) V DC/AC	99.01.0.060.09
RC	(110...240) V DC/AC	99.01.0.230.09
Residual current bypass (62 kΩ/1W)	(110...240) V AC	99.01.8.230.07

\*\*For DC supply, apply the positive to terminal A1. Modules in Black housing are available on request. Green LED is standard. Red LED available on request.





Relay type	40.31		40.51, 40.52, 40.61	
	BLUE	BLACK	BLUE	BLACK
<b>P.C.B. socket</b>	95.13	95.13.0	95.15	95.15.0
retaining clip 095.51 supplied with socket packaging code SMA				
Metal retaining clip	095.51			
Plastic retaining clip	095.52			

40

Approvals  
(according to type):



- RATED VALUES: 10 A - 250 V
- INSULATION:  $\geq 6$  kV (1.2/50 $\mu$ s) between coil and contacts
- PROTECTION CATEGORY: IP 20
- AMBIENT TEMPERATURE: (-40...+70) °C

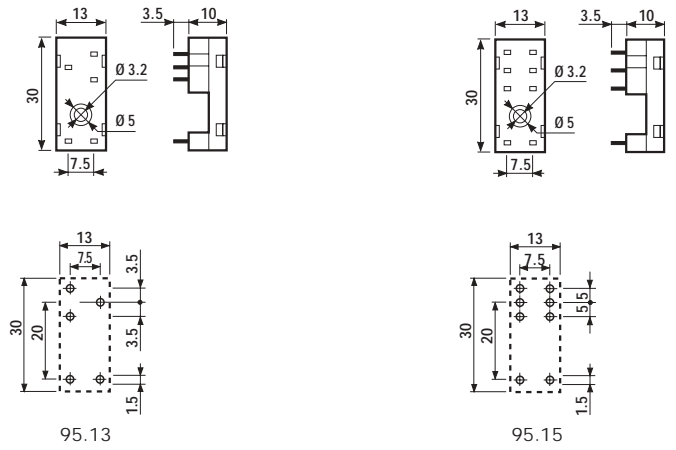

Copper side view

## PACKAGING CODES

**How to code and identify retaining clip and packaging options for sockets.**

Code options according to the last three letters:

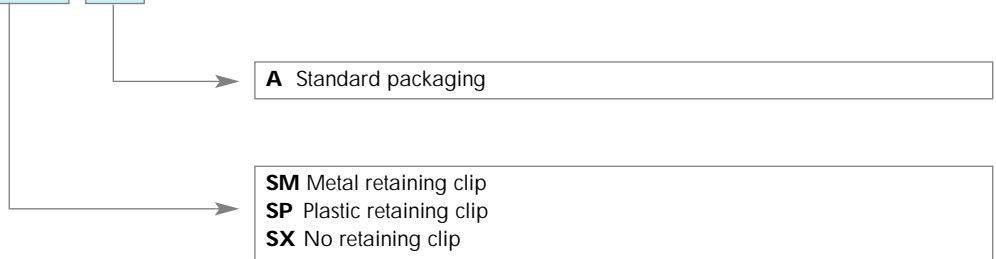

- Low-profile, only 15.7 mm high
- DC coil versions 0.4 W
- 8 mm, 6 kV(1.2/50 μs) between coil and contacts
- Ambient temperature +85°C
- Sockets and accessories: see 95 and 99 series

41

### 41.31

### 41.52

### 41.61



- |  |   |  |
|--|---|--|
| <ul style="list-style-type: none"> <li>- 1 pole, 12 A</li> <li>- low profile, 3.5 mm pinning</li> <li>- P.C.B. / for use with 95 series sockets</li> </ul> | <ul style="list-style-type: none"> <li>- 2 pole, 8 A</li> <li>- low profile, 5 mm pinning</li> <li>- P.C.B. / for use with 95 series sockets</li> </ul> | <ul style="list-style-type: none"> <li>- 1 pole, 16 A</li> <li>- low profile, 5 mm pinning</li> <li>- P.C.B. / for use with 95 series sockets</li> </ul> |
|--|---|--|

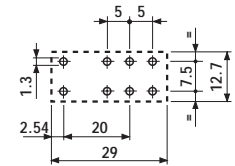
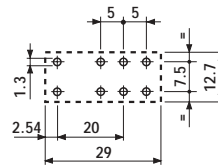
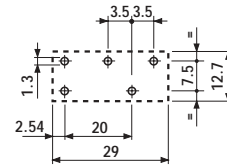
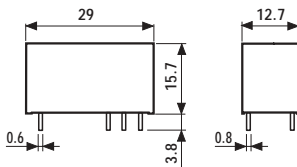
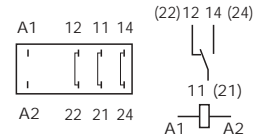
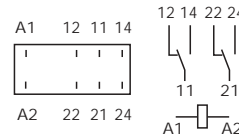
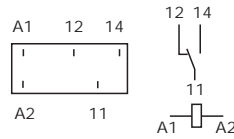

\* for 400 V applications, requirements for pollution degree 2 are met.

Contact specifications				
Contact configuration		1 CO	2 CO	1 CO
Rated current/Maximum peak current	A	12/25	8/15	16/30
Rated voltage/Maximum switching voltage	V AC	250/400*	250/400*	250/400*
Rated load in AC1	VA	3,000	2,000	4,000
Rated load in AC15 (230 VAC)	VA	600	400	750
Single phase motor rating (230 VAC)	kW	0.5	0.3	0.5
Breaking capacity in DC1: 30/110/220V	A	12/0.3/0.12	8/0.3/0.12	16/0.3/0.12
Minimum switching load	mW (V/mA)	300 (5/5)	300 (5/5)	300 (5/5)
Standard contact material		AgNi	AgNi	AgNi
Coil specifications				
Nominal voltage (U <sub>N</sub> )	V AC (50/60 Hz)	—	—	—
	V DC	12 · 24 · 48 · 60 · 110	12 · 24 · 48 · 60 · 110	12 · 24 · 48 · 60 · 110
Rated power AC/DC	VA (50 Hz)/W	—/0.4	—/0.4	—/0.4
Operating range	AC (50 Hz)	—	—	—
	DC	(0.7...1.5)U <sub>N</sub>	(0.7...1.5)U <sub>N</sub>	(0.7...1.5)U <sub>N</sub>
Holding voltage	AC/DC	—/0.4U <sub>N</sub>	—/0.4 U <sub>N</sub>	—/0.4 U <sub>N</sub>
Must drop-out voltage	AC/DC	—/0.1U <sub>N</sub>	—/0.1 U <sub>N</sub>	—/0.1 U <sub>N</sub>
Technical data				
Mechanical life AC/DC	cycles	—/30 · 10 <sup>6</sup>	—/30 · 10 <sup>6</sup>	—/30 · 10 <sup>6</sup>
Electrical life at rated load AC1	cycles	150 · 10 <sup>3</sup>	80 · 10 <sup>3</sup>	70 · 10 <sup>3</sup>
Operate/release time (bounce included)	ms	7/8	7/8	7/8
Insulation according to EN 61810-5		3.6kV/3	3.6kV/3	3.6kV/3
Insulation between coil and contacts (1.2/50μs)	kV	6 (8mm)	6 (8mm)	6 (8mm)
Dielectric strength between open contacts	V AC	1,000	1,000	1,000
Ambient temperature range	°C	-40...+85	-40...+85	-40...+85
Environmental protection		RT II	RT II	RT II

**Approvals:** (according to type)



## ORDERING INFORMATION

Example: a 41 series low-profile P.C.B. relay with 2 CO contacts, with coil rated 24 V DC.

4

1

.

5

.

2

.

9

.

0

2

4

.

0

0

.

1

0

**Series** —————

**Type** —————  
 3 = P.C.B. - 3.5 mm pinning  
 5 = P.C.B. - 5 mm pinning  
 6 = P.C.B. - 5 mm pinning

**No. of poles** —————  
 1 = 1 pole for  
     41.31, 12 A  
     41.61, 16 A  
 2 = 2 pole for  
     41.52, 8 A

**Coil version** —————  
 9 = DC

**Coil voltage** —————  
 see coil specifications

**A: Contact material**  
 0 = Standard AgNi

**B: Contact circuit** —————  
 0 = CO

**C: Options**  
 1 = None

**D: Special versions**  
 0 = Flux proof (RT II)  
 1 = Wash tight (RT III)

## TECHNICAL DATA

### INSULATION

INSULATION according to EN 61810-5	insulation rated voltage	V	250
	rated impulse withstand voltage	kV	3.6
	pollution degree		3
	overvoltage category		III

### OTHER DATA

VIBRATION RESISTANCE (10...55Hz): NO/NC	g/g	20/5		
POWER LOST TO THE ENVIRONMENT	without contact current	W		
	with rated current	W	1.7 (41.31)	1.2 (41.52)      1.8 (41.61)
RECOMMENDED DISTANCE between RELAYS mounted on P.C.B.s	mm	≥5		

## CONTACT SPECIFICATIONS

### F 41

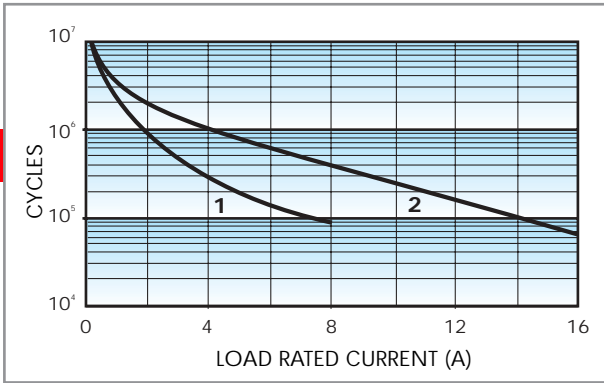

Contact life vs AC1 load.

- 1** - Type 41.52 (8 A) at 360 cycles/h.
- 2** - Type 41.31 (12 A) at 360 cycles/h.
- Type 41.61 (16 A) at 360 cycles/h.

### H 41

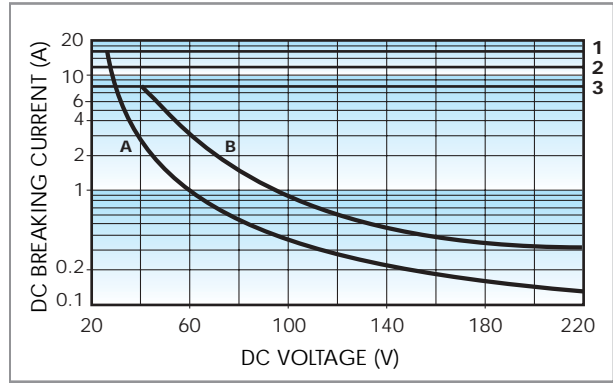

Breaking capacity for DC1 load.

- 1** - Type 41.61
- 2** - Type 41.31
- 3** - Type 41.52
- A** - Load applied to 1 contact
- B** - Load applied to 2 contacts in series

- When switching a resistive load (DC1) having voltage and current values under the curve the expected electrical life is  $\geq 100 \cdot 10^3$  cycles.
  - In case of DC13 loads the connection of a diode in parallel with the load will permit the same electrical life as for a DC1 load.
- Note:** the release time of load will be increase.

## COIL SPECIFICATIONS

### DC VERSION DATA

Nominal voltage $U_N$ V	Coil code	Operating range		Resistance R $\Omega$	Rated coil consumption I at $U_N$ mA
		$U_{min}$ V	$U_{max}$ V		
12	9.012	8.4	18	360	33.3
24	9.024	16.8	36	1,440	19.7
48	9.048	33.6	72	5,520	8.7
60	9.060	42	90	7,340	8.1
110	9.110	77	165	26,600	4.1

### R 41 DC

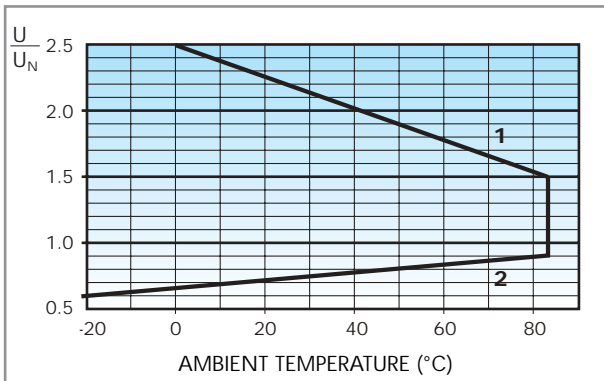

Operating range vs ambient temperature.

- 1** - Max coil voltage permitted.
- 2** - Min pick-up voltage with coil at ambient temperature.



Relay type	41.31		41.52, 41.61	
Colour	BLUE	BLACK	BLUE	BLACK
<b>P.C.B. socket</b>	95.13	95.13.0	95.15	95.15.0
retaining clip 095.41 supplied with socket packaging code SNA				
Metal retaining clip	095.41			
Plastic retaining clip	095.42			

Approvals  
(according to type):



- RATED VALUES: 10 A - 250 V
- INSULATION:  $\geq 6$  kV (1.2/50 $\mu$ s) between coil and contacts
- PROTECTION CATEGORY: IP 20
- AMBIENT TEMPERATURE: (-40...+70) °C

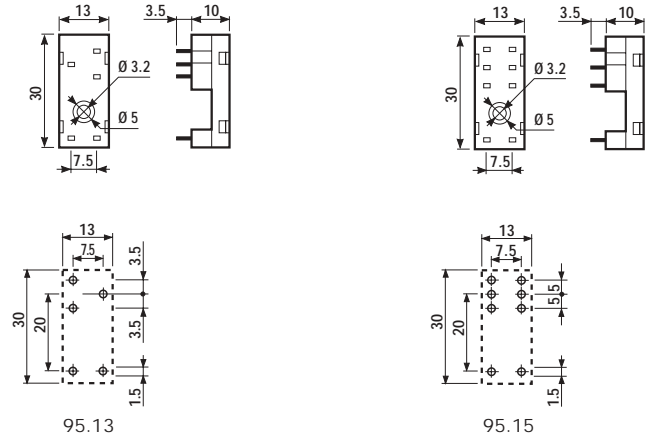

Copper side view

## PACKAGING CODES

How to code and identify retaining clip and packaging options for sockets.

Code options according to the last three letters:

**9 5 1 3 S N A**

**A** Standard packaging

**SN** Low profile metal retaining clip  
**SL** Low profile plastic retaining clip  
**SX** No retaining clip

- 1 pole 10A
- 15.4 mm high
- Very low coil consumption, only 0.25 W
- 10 mm, 6 kV (1.2/50 μs) between coil and contacts
- Ambient temperature +85°C
- Sockets: see Type 95.23

43

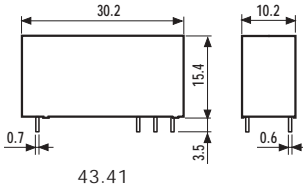

43.41

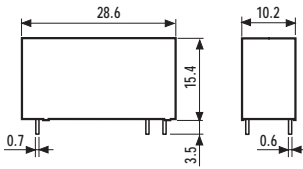

43.41-0300

\* for 400 V applications, requirements for pollution degree 2 are met.

### 43.41

### 43.41...0300



- 1 CO
- 3.2 mm pinning
- P.C.B. mounting or sockets 95 series

- 1 NO
- 5 mm pinning
- P.C.B. mounting

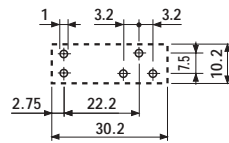
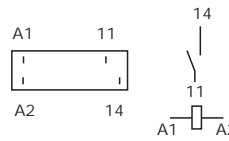
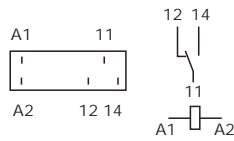

Copper side view

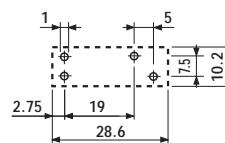

Copper side view

Contact specifications			
Contact configuration		1 CO	1 NO
Rated current/Maximum peak current	A	10/15	10/15
Rated voltage/Maximum switching voltage	V AC	250/400*	250/400*
Rated load in AC1	VA	2,500	2,500
Rated load in AC15 (230 VAC)	VA	500	500
Single phase motor rating (230 VAC)	kW	—	—
Breaking capacity in DC1: 30/110/220V	A	10/0.3/0.12	10/0.3/0.12
Minimum switching load	mW (V/mA)	300 (5/5)	300 (5/5)
Standard contact material		AgCdO	AgCdO
Coil specifications			
Nominal voltage (U <sub>N</sub> )	V AC (50/60 Hz)	—	—
	V DC	3 - 6 - 9 - 12 - 18 - 24 - 36 - 48	3 - 6 - 9 - 12 - 18 - 24 - 36 - 48
Rated power AC/DC	VA (50 Hz)/W	—/0.25	—/0.25
Operating range	AC (50 Hz)	—	—
	DC	(0.7...1.5)U <sub>N</sub>	(0.7...1.5)U <sub>N</sub>
Holding voltage	AC/DC	—/0.4 U <sub>N</sub>	—/0.4 U <sub>N</sub>
Must drop-out voltage	AC/DC	—/0.05 U <sub>N</sub>	—/0.05 U <sub>N</sub>
Technical data			
Mechanical life AC/DC	cycles	—/10 · 10 <sup>6</sup>	—/10 · 10 <sup>6</sup>
Electrical life at rated load AC1	cycles	100 · 10 <sup>3</sup>	100 · 10 <sup>3</sup>
Operate/release time (bounce included)	ms	11/8	11/8
Insulation according to EN 61810-5		3.6 kV/3	3.6 kV/3
Insulation between coil and contacts (1.2/50μs)	kV	6 (10mm)	6 (10mm)
Dielectric strength between open contacts	V AC	1,000	1,000
Ambient temperature range	°C	−40...+85	−40...+85
Environmental protection		RT II	RT II
<b>Approvals:</b> (according to type)		GOST	GOST

## ORDERING INFORMATION

Example: a 43 series low-profile P.C.B. relay with 1 CO contact, with coil rated 24 V DC.

	<b>4</b>	<b>3</b>	.	<b>4</b>	<b>1</b>	.	<b>7</b>	.	<b>0</b>	<b>2</b>	<b>4</b>	.	<b>2</b>	<b>0</b>	<b>0</b>	<b>0</b>
<b>Series</b>																
<b>Type</b> 4 = P.C.B. - 3.2 mm pinning																
<b>No. of poles</b> 1 = 1 pole, 10 A																
<b>Coil version</b> 7 = Sensitive DC																
<b>Coil voltage</b> see coil specifications																
												<b>A: Contact material</b> 2 = Standard AgCdO 4 = AgSnO <sub>2</sub> 5 = AgNi + Au				
												<b>B: Contact circuit</b> 0 = CO 3 = NO				
														<b>D: Special versions</b> 0 = Flux proof (RT II) 1 = Wash tight (RT III)		
														<b>C: Options</b> 0 = None		

Only combinations in the same row are possible

Preferred versions

	coil version	A	B	C	D
43.41	sens. DC	2	0	0	0

All versions

	coil version	A	B	C	D
43.41	sens. DC	2 - 4 - 5	0 - 3	0	0 - 1

## TECHNICAL DATA

### INSULATION

INSULATION according to EN 61810-5	insulation rated voltage	V	250
	rated impulse withstand voltage	kV	3.6
	pollution degree		3
	overvoltage category		III

### OTHER DATA

VIBRATION RESISTANCE (10...55Hz): NO/NC	g/g	10/10
POWER LOST TO THE ENVIRONMENT	without contact current	W
	with rated current	W
RECOMMENDED DISTANCE between RELAYS mounted on P.C.B.s	mm	!5

## CONTACT SPECIFICATIONS

### F 43

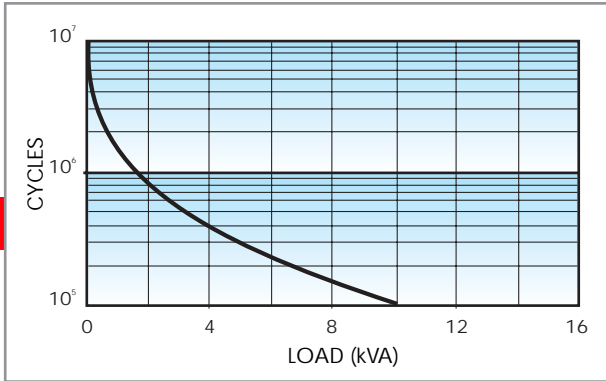

Electrical life vs AC1 load.

### H 43

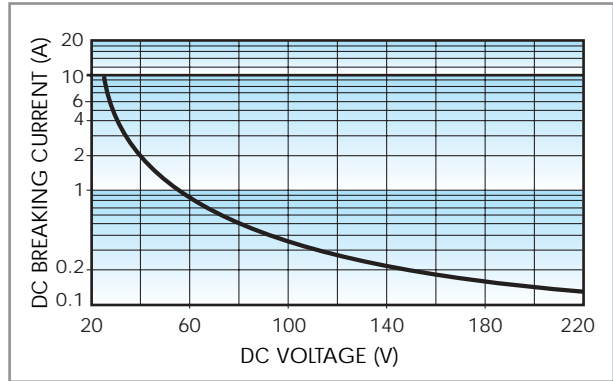

Breaking capacity in DC1 load.

- When switching a resistive load (DC1) having voltage and current values under the curve the expected electrical life is ! 100·10<sup>3</sup> cycles.
  - In case of DC13 loads the connection of a diode in parallel with the load will permit the same electrical life as for a DC1 load.
- Note:** the release time of load will be increase.

## COIL SPECIFICATIONS

### DC VERSION DATA

Nominal voltage $U_N$ V	Coil code	Operating range		Resistance R $\Omega$	Rated coil consumption I at $U_N$ mA
		$U_{min}$ V	$U_{max}$ V		
3	7.003	2.2	4.5	36	83.5
6	7.006	4.2	9	150	40
9	7.009	6.5	13.5	324	27.7
12	7.012	8.4	18	580	20.7
18	7.018	13	27	1,296	13.8
24	7.024	16.8	36	2,200	10.9
36	7.036	25.2	54	5,184	6.9
48	7.048	33.6	72	9,200	5.2

### R 43 DC

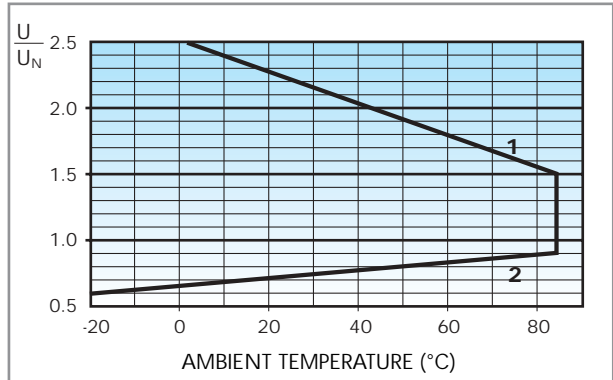

Operating range vs ambient temperature.

- 1 - Max coil voltage permitted.
- 2 - Min pick-up voltage with coil at ambient temperature.





<b>Relay type</b>	<b>43.41</b>	
Colour	BLUE	BLACK
<b>P.C.B. socket</b> (only for CO version)	95.23	95.23.0
retaining clip 095.43 supplied with socket packaging code SNA		
Metal retaining clip	095.43	

Approvals  
(according to type):



- RATED VALUES: 10 A - 250 V
- INSULATION: ! 6 kV (1.2/50µs) between coil and contacts
- PROTECTION CATEGORY: IP 20
- AMBIENT TEMPERATURE: (-40...+70)°C

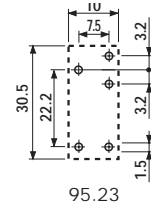
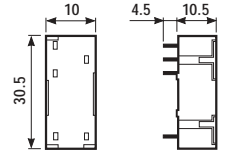

Copper side view

43

## PACKAGING CODES

How to code and identify retaining clip and packaging options for sockets.

Code options according to the last three letters:

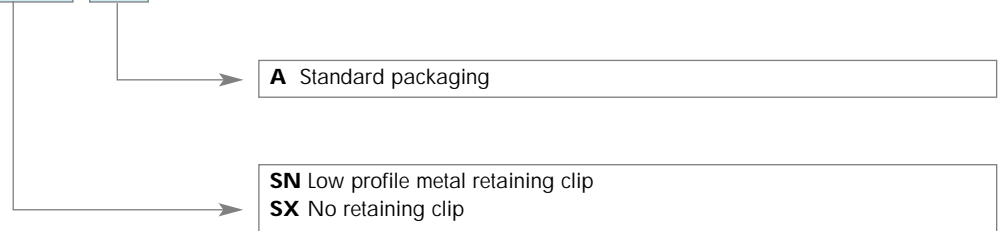

- DC and sensitive DC available
- 8 mm, 6 kV (1.2/50 μs) between coil and contacts
- Ambient temperature +85°C
- Sockets and accessories: see 95, 99 and 86 series

44

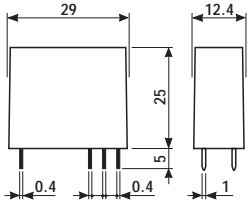

\* for 400 V applications, requirements for pollution degree 2 are met.

### 44.52

### 44.62

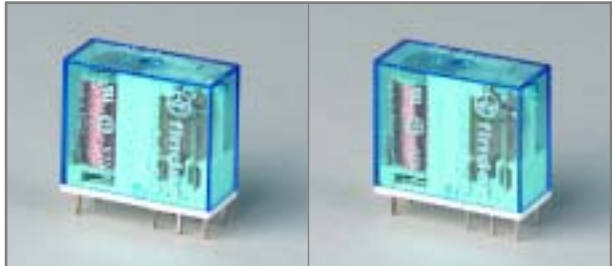

- |   |  |
|---|--|
| <ul style="list-style-type: none"> <li>- 2 pole, 6 A</li> <li>- 5 mm pinning</li> <li>- P.C.B./ for use with 95 series sockets</li> </ul> | <ul style="list-style-type: none"> <li>- 2 pole, 10 A</li> <li>- 5 mm pinning</li> <li>- P.C.B./ for use with 95 series sockets</li> </ul> |
|---|--|

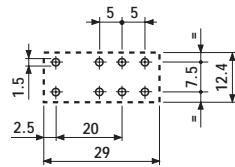
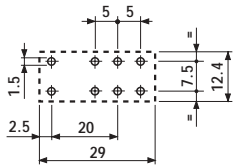
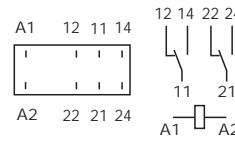
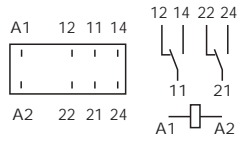

Copper side view

Copper side view

Contact specifications			
Contact configuration		2 CO	2 CO
Rated current/Maximum peak current	A	6/10	10/20
Rated voltage/Maximum switching voltage	V AC	250/400*	250/400*
Rated load in AC1	VA	1,500	2,500
Rated load in AC15 (230 VAC)	VA	250	500
Single phase motor rating (230 VAC)	kW	0.185	0.37
Breaking capacity in DC1: 30/110/220V	A	6/0.3/0.13	10/0.3/0.13
Minimum switching load	mW (V/mA)	300 (5/5)	300 (5/5)
Standard contact material		AgNi	AgNi
Coil specifications			
Nominal voltage (U <sub>N</sub> )	V AC (50/60 Hz)	—	—
	V DC	6 · 9 · 12 · 14 · 24 · 28 · 48 · 60 · 110	
Rated power AC/DC/sens. DC	VA (50 Hz)/W	—/0.65/0.5	—/0.65/0.5
Operating range	AC (50 Hz)	—	—
	DC/sens. DC	(0.73...1.5)U <sub>N</sub> /(0.73...1.7)U <sub>N</sub> (0.73...1.5)U <sub>N</sub> /(0.8...1.7)U <sub>N</sub>	
Holding voltage	AC/DC	—/0.4 U <sub>N</sub>	—/0.4 U <sub>N</sub>
Must drop-out voltage	AC/DC	—/0.1 U <sub>N</sub>	—/0.1 U <sub>N</sub>
Technical data			
Mechanical life AC/DC	cycles	—/20 · 10 <sup>6</sup>	—/20 · 10 <sup>6</sup>
Electrical life at rated load AC1	cycles	150 · 10 <sup>3</sup>	100 · 10 <sup>3</sup>
Operate/release time (bounce included)	ms	10/12 · (15/12 sens)	10/12 · (15/12 sens)
Insulation according to EN 61810-5		3.6 kV/3	3.6 kV/3
Insulation between coil and contacts (1.2/50μs)	kV	6 (8mm)	6 (8mm)
Dielectric strength between open contacts	V AC	1,000	1,000
Ambient temperature range	°C	-40...+85	-40...+85
Environmental protection		RT II	RT II
Approvals: (according to type)			
		GOST          RINA	

## ORDERING INFORMATION

Example: a 44 series P.C.B. relay with 2 CO 10 A contacts, coil rated 24 V DC.

4

4

.

6

.

2

.

9

.

0

2

4

.

A

0

.

B

0

.

C

0

.

D

0

**Series** —————

**Type** —————

5 = P.C.B. - 5 mm pinning  
6 = P.C.B. - 5 mm pinning

**No. of poles** —————

2 = 2 pole for  
44.52, 6 A  
44.62, 10 A

**Coil version** —————

7 = Sensitive DC  
9 = DC

**Coil voltage** —————

see coil specifications

**A: Contact material**  
0 = Standard AgNi  
4 = AgSnO<sub>2</sub>  
for 44.62 only

**B: Contact circuit**  
0 = CO

**C: Options**  
0 = None

**D: Special versions**  
0 = Flux proof (RT II)

**Only combinations in the same row are possible**

Preferred versions

	coil version	A	B	C	D
44.52	DC - sens. DC	0	0	0	0
44.62	DC - sens. DC	0	0	0	0

All versions

	coil version	A	B	C	D
44.62	DC - sens. DC	0 - 4	0	0	0

## TECHNICAL DATA

### INSULATION

INSULATION according to EN 61810-5	insulation rated voltage	V	250
	rated impulse withstand voltage	kV	3.6
	pollution degree		3
	overvoltage category		III

### IMMUNITY

CONDUCTED DISTURBANCE IMMUNITY	BURST (according to EN 61000-4-4) level 4 (4kV)
	SURGE (according to EN 61000-4-5) level 3 (2kV)

### OTHER DATA

VIBRATION RESISTANCE (10...55Hz): NO/NC	g/g	3/3
POWER LOST TO THE ENVIRONMENT	without contact current	W
	with rated current	W
		0.6
		1.2 (44.52)      2.7 (44.62)
RECOMMENDED DISTANCE between RELAYS mounted on P.C.B.s	mm	≥5

## CONTACT SPECIFICATIONS

### F 44

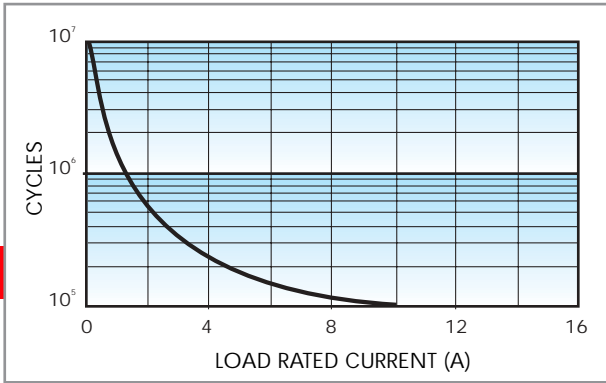

Electrical life vs AC1 load.

### H 44

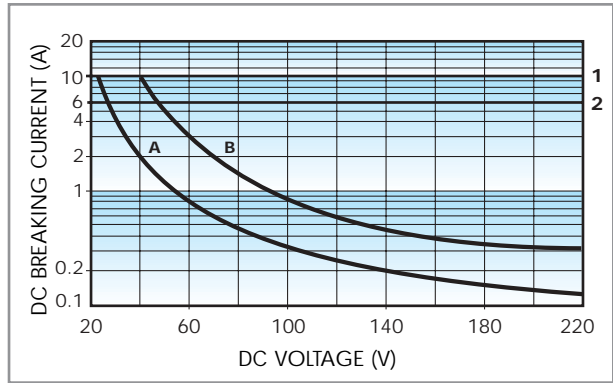

Breaking capacity for DC1 load.

- 1** - Type 44.62
- 2** - Type 44.52
- A** - Load applied to 1 contact
- B** - Load applied to 2 contacts in series

- When switching a resistive load (DC1) having voltage and current values under the curve the expected electrical life is  $\geq 100 \cdot 10^3$  cycles.
- In case of DC13 loads the connection of a diode in parallel with the load will permit the same electrical life as for a DC1 load.
- Note:** the release time of load will be increase.

## COIL SPECIFICATIONS

### DC VERSION DATA (0.65 W standard)

Nominal voltage $U_N$ V	Coil code	Operating range		Resistance R $\Omega$	Rated coil consumption I at $U_N$ mA
		$U_{min}$ V	$U_{max}$ V		
6	9.006	4.4	9	55	109
9	9.009	6.6	13.5	125	72
12	9.012	8.8	18	220	55
14	9.014	10.2	21	300	47
24	9.024	17.5	36	900	27
28	9.028	20.5	42	1,200	23
48	9.048	35	72	3,500	14
60	9.060	43.8	90	5,500	11
110	9.110	80.3	165	18,000	6.2

### DC VERSION DATA (0.5 W sensitive)

Nominal voltage $U_N$ V	Coil code	Operating range		Resistance R $\Omega$	Rated coil consumption I at $U_N$ mA
		$U_{min}^*$ V	$U_{max}$ V		
6	7.006	4.4	10.2	75	80
9	7.009	6.6	15.3	160	56
12	7.012	8.8	20.4	300	40
14	7.014	10.2	23.8	400	35
24	7.024	17.5	40.8	1,200	20
28	7.028	20.5	47.6	1,600	17.5
48	7.048	35	81.6	4,800	10
60	7.060	43.8	102	7,200	8.4
110	7.110	80.3	187	23,500	4.7

\* $U_{min} = 0.8 U_N$  for 44.62

### R 44 DC

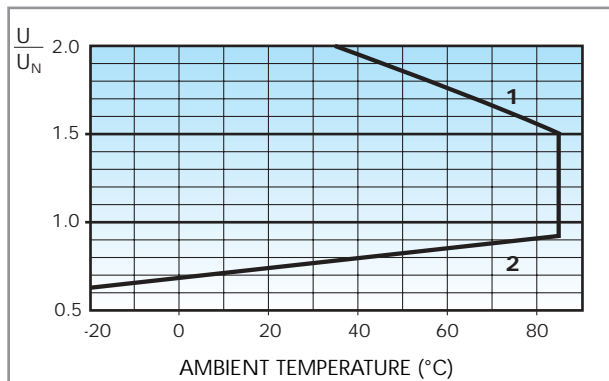

- Operating range (DC version) vs ambient temperature.
- 1** - Max coil voltage permitted.
  - 2** - Min pick-up voltage with coil at ambient temperature.

### R 44 sens. DC

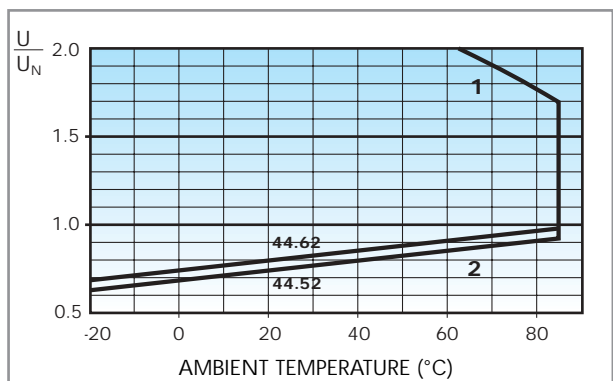

- Operating range (sensitive DC version) vs ambient temperature.
- 1** - Max coil voltage permitted.
  - 2** - Min pick-up voltage with coil at ambient temperature.



95.05

Approvals  
(according to type):



095.01

- RATED VALUES: 10 A - 250 V
- INSULATION:  $\geq 6$  kV (1.2/50 $\mu$ s) between coil and contacts
- PROTECTION CATEGORY: IP 20
- AMBIENT TEMPERATURE: (-40...+70) °C
- SCREW TORQUE: 0.5 Nm
- WIRE STRIP LENGTH: 8 mm
- MAX WIRE SIZE:

	solid wire	stranded wire
mm <sup>2</sup>	1x6 / 2x2.5	1x4 / 2x2.5
AWG	1x10 / 2x14	1x12 / 2x14

Relay type	44.52, 44.62	
Colour	BLUE	BLACK
Clamp terminal socket: panel or 35 mm rail (EN 50022) mount retaining clip 095.01 supplied with socket packaging code SPA	95.05	95.05.0
Retaining and release clip	095.01	095.01.0
Metal retaining clip	095.71	
8-way jumper link for 95.03 and 95.05 sockets	095.18	095.18.0
Identification tag	095.00.4	
Modules (see table below)	99.02	
Timer modules	86.10, 86.20	

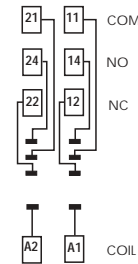
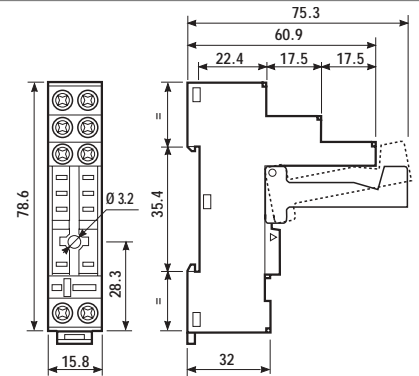

095.18

- RATED VALUES: 10 A - 250 V

<b>8-way jumper link for 95.03, and 95.05 sockets</b>	095.18
---	--------

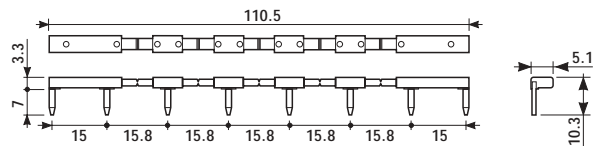

99.02

99.02 modules for 95.03 and 95.05 sockets		BLUE
Diode** (+A1)	(6...220) V DC	99.02.3.000.00
LED	(6...24) V DC/AC	99.02.0.024.59
LED	(28...60) V DC/AC	99.02.0.060.59
LED	(110...240) V DC/AC	99.02.0.230.59
LED + Diode** (+A1)	(6...24) V DC	99.02.9.024.99
LED + Diode** (+A1)	(28...60) V DC	99.02.9.060.99
LED + Diode** (+A1)	(110...220) V DC	99.02.9.220.99
LED + Varistor	(6...24) V DC/AC	99.02.0.024.98
LED + Varistor	(28...60) V DC/AC	99.02.0.060.98
LED + Varistor	(110...240) V DC/AC	99.02.0.230.98
RC	(6...24) V DC/AC	99.02.0.024.09
RC	(28...60) V DC/AC	99.02.0.060.09
RC	(110...240) V DC/AC	99.02.0.230.09
No - remanence (62 k $\Omega$ /1W)	(110...240) V AC	99.02.8.230.07

\*\*For DC supply, apply the positive to terminal A1.

Modules in Black housing are available on request.



Relay type	44.52, 44.62			
Colour	BLUE	BLACK	BLUE	BLACK
Clamp terminal socket: panel or 35 mm rail (EN 50022) mount retaining clip 095.71 supplied with socket packaging code SMA	95.65	95.65.0	95.75	95.75.0
Metal retaining clip	095.71			
8-way jumper link for 95.65 and 95.75 sockets	095.08	095.08.0	095.08	095.08.0
Modules (see table below)	—			99.01

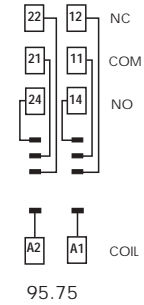
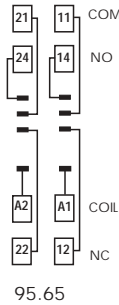
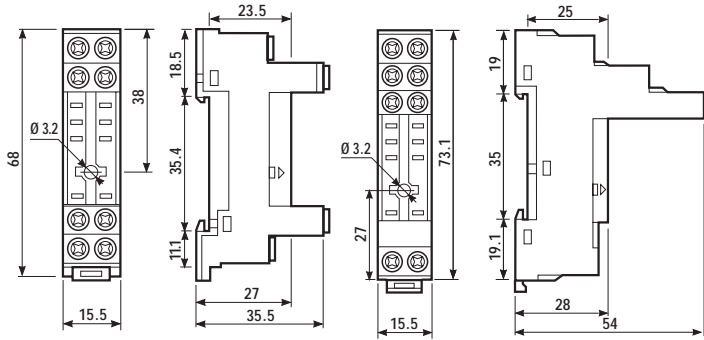

44

Approvals (according to type):



- RATED VALUES: 10 A - 250 V
- INSULATION:  $\geq 6$  kV (1.2/50 $\mu$ s) between coil and contacts (Type 95.75 only)
- PROTECTION CATEGORY: IP 20
- AMBIENT TEMPERATURE: (-40...+70) °C
- SCREW TORQUE: 0.5 Nm
- WIRE STRIP LENGTH: 7 mm
- MAX WIRE SIZE:

	solid wire	stranded wire
mm <sup>2</sup>	1x6 / 2x2.5	1x4 / 2x2.5
AWG	1x10 / 2x14	1x12 / 2x14



8-way jumper link for 95.65 and 95.75 sockets	095.08
---	--------

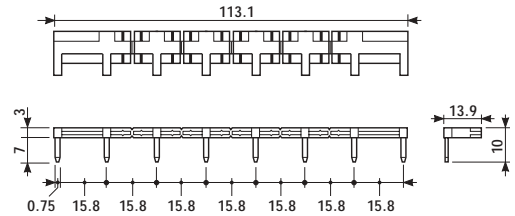

- RATED VALUES: 10 A - 250 V



99.01 modules for 95.63 and 95.75 sockets		BLUE
Diode** (+A1)	(6...220) V DC	99.01.3.000.00
LED	(6...24) V DC/AC	99.01.0.024.59
LED	(28...60) V DC/AC	99.01.0.060.59
LED	(110...240) V DC/AC	99.01.0.230.59
LED + Diode** (+A1)	(6...24) V DC	99.01.9.024.99
LED + Diode** (+A1)	(28...60) V DC	99.01.9.060.99
LED + Diode** (+A1)	(110...220) V DC	99.01.9.220.99
LED + Varistor	(6...24) V DC/AC	99.01.0.024.98
LED + Varistor	(28...60) V DC/AC	99.01.0.060.98
LED + Varistor	(110...240) V DC/AC	99.01.0.230.98
RC	(6...24) V DC/AC	99.01.0.024.09
RC	(28...60) V DC/AC	99.01.0.060.09
RC	(110...240) V DC/AC	99.01.0.230.09
No - remanence (62 k $\Omega$ /1W)	(110...240) V AC	99.01.8.230.07

\*\*For DC supply, apply the positive to terminal A1. Modules in Black housing are available on request. Green LED is standard. Red LED available on request.



95.15

Approvals  
(according to type):



- RATED VALUES: 10 A - 250 V
- INSULATION:  $\geq 6$  kV (1.2/50 $\mu$ s) between coil and contacts
- PROTECTION CATEGORY: IP 20
- AMBIENT TEMPERATURE: (-40...+70) $^{\circ}$ C

<b>Relay type</b>	<b>44.52, 44.62</b>	
Colour	BLUE	BLACK
<b>P.C.B. socket</b>	95.15	95.15.0
retaining clip 095.51 supplied with socket with packaging code SMA		
Retaining clip		095.51
Plastic retaining clip		095.52

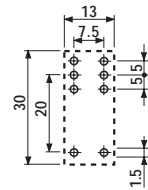
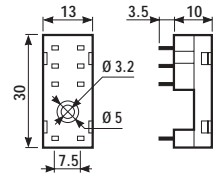

95.15

Copper side view

## PACKAGING CODES

How to code and identify retaining clip and packaging options for sockets.

Code options according to the last three letters:



**A** Standard packaging

**SM** Metal retaining clip  
**SP** Plastic retaining clip  
**SX** No retaining clip

## 45.71

- Miniature P.C.B. Faston 250 connect relay
- Sensitive DC coil
- 8 mm, 6 kV (1.2/50 μs) between coil and contacts
- Ambient temperature +125°C
- NO contact or NC contact version



- 1 NO or 1 NC
- Max ambient temperature +125°C
- P.C.B. mounting + Faston 250

45

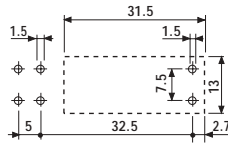
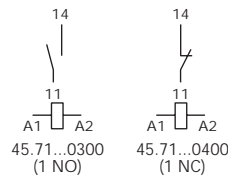
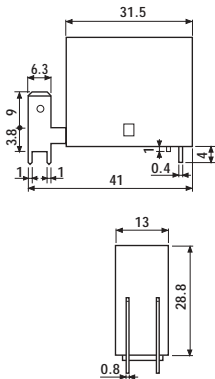

Copper side view

\* for 400 V applications, requirements for pollution degree 2 are met.

Contact specifications		
Contact configuration		1 NO /1 NC
Rated current/Maximum peak current	A	16/30
Rated voltage/Maximum switching voltage	V AC	250/400*
Rated load in AC1	VA	4,000
Rated load in AC15 (230 VAC)	VA	750
Single phase motor rating (230 VAC)	kW	0.55
Breaking capacity in DC1: 30/110/220V	A	16/0.3/0.13
Minimum switching load	mW (V/mA)	500 (10/5)
Standard contact material		AgCdO
Coil specifications		
Nominal voltage (U <sub>N</sub> )	V AC (50/60 Hz)	—
	V DC	6 · 12 · 24 · 48 · 60
Rated power AC/DC	VA (50 Hz)/W	—/0.36
Operating range	AC (50 Hz)	—
	DC	(0.7...1.2)U <sub>N</sub>
Holding voltage	AC/DC	—/0.4 U <sub>N</sub>
Must drop-out voltage	AC/DC	—/0.1 U <sub>N</sub>
Technical data		
Mechanical life AC/DC	cycles	—/30 · 10 <sup>6</sup>
Electrical life at rated load AC1	cycles	100 · 10 <sup>3</sup>
Operate/release time (bounce included)	ms	8/3
Insulation according to EN 61810-5		3.6 kV/3
Insulation between coil and contacts (1.2/50μs)	kV	6 (8mm)
Dielectric strength between open contacts	V AC	1,000
Ambient temperature range	°C	-40...+125
Environmental protection		RT II
<b>Approvals:</b> (according to type)		GOST



## ORDERING INFORMATION

Example: a 45 series for P.C.B. relay + Faston 250, 1 NO contact, coil rated 12 V DC.

<b>4</b>	<b>5</b>	<b>7</b>	<b>1</b>	<b>7</b>	<b>0</b>	<b>1</b>	<b>2</b>	<b>0</b>	<b>3</b>	<b>0</b>	<b>0</b>	
<b>Series</b>		<b>Type</b>			<b>A: Contact material</b>				<b>B: Contact circuit</b>		<b>C: Options</b>	
7 = P.C.B. - Faston 250		1 = 1 pole, 16 A			0 = Standard AgCdO				3 = NO		0 = Flux proof (RT II)	
<b>No. of poles</b>		<b>Coil version</b>			<b>B: Contact circuit</b>				4 = NC		<b>C: Options</b>	
1 = 1 pole, 16 A		7 = Sensitive DC									0 = None	
<b>Coil voltage</b>		see coil specifications										

## TECHNICAL DATA

### INSULATION

INSULATION according to EN 61810-5	insulation rated voltage	V	250
	rated impulse withstand voltage	kV	3.6
	pollution degree		3
	overvoltage category		III

### OTHER DATA

VIBRATION RESISTANCE (10...55Hz): NO/NC	g/g	10/10	
POWER LOST TO THE ENVIRONMENT	without contact current	W	0.4
	with rated current	W	1.8
RECOMMENDED DISTANCE between RELAYS mounted on P.C.B.s	mm	≥5	

## CONTACT SPECIFICATIONS

### F 45

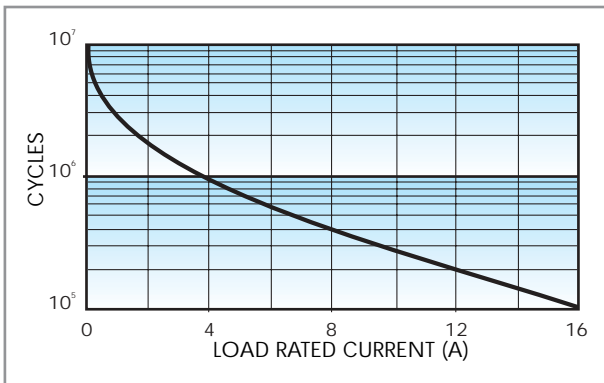

Electrical life AC1 load (+85°C).

### H 45

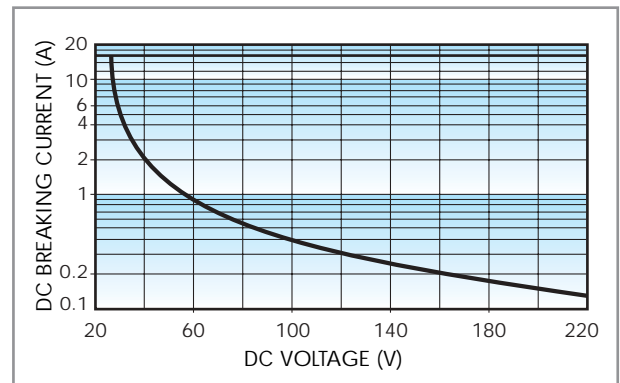

Breaking capacity for DC1 load.

- When switching a resistive load (DC1) having voltage and current values under the curve the expected electrical life is  $\geq 100 \cdot 10^3$  cycles.
  - In case of DC13 loads the connection of a diode in parallel with the load will permit the same electrical life as for a DC1 load.
- Note:** the release time of load will be increase.

## COIL SPECIFICATIONS

### DC VERSION DATA (0.36 W sensitive)

Nominal voltage $U_N$ V	Coil code	Operating range		Resistance R $\Omega$	Rated coil consumption I at $U_N$ mA
		$U_{min}$ V	$U_{max}$ V		
6	7.006	4.2	7.2	100	60
12	7.012	8.4	14.4	400	30
24	7.024	16.8	28.8	1,600	15
48	7.048	33.6	57.6	6,400	7.5
60	7.060	42	72	10,000	6

45

### R 45 DC

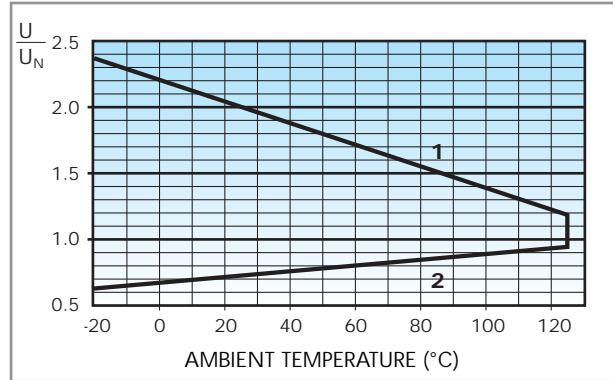

Operating range vs ambient temperature.

1 - Max coil voltage permitted.

2 - Min pick-up voltage with coil at ambient temperature.

- Plug-in or P.C.B. versions
- AC or DC coils
- Lockable test button and mechanical flag indicator as standard on 2 and 4 CO relays types
- Sockets and accessories: see 94, 99 and 86 series
- RT III (wash tight) version available

	55.12	55.13	55.14
	- 2 pole - P.C.B. mounting	- 3 pole - P.C.B. mounting	- 4 pole - P.C.B. mounting
	 Copper side view h = 35.8 mm	 Copper side view h = 35.8 mm	 Copper side view h = 35.8 mm
<b>Contact specifications</b>			
Contact configuration	2 CO	3 CO	4 CO
Rated current/Maximum peak current A	10/20	10/20	5/10
Rated voltage/Maximum switching voltage V AC	250/400	250/400	250/250
Rated load in AC1 VA	2,500	2,500	1,250
Rated load in AC15 (230 VAC) VA	500	500	250
Single phase motor rating (230 VAC) kW	0.37	0.37	0.125
Breaking capacity in DC1: 30/110/220V A	10/0.25/0.12	10/0.25/0.12	5/0.25/0.12
Minimum switching load mW (V/mA)	300 (5/5)	300 (5/5)	300 (5/5)
Standard contact material	AgNi	AgNi	AgNi
<b>Coil specifications</b>			
Nominal voltage (U <sub>N</sub> ) V AC (50/60 Hz)	6 - 12 - 24 - 48 - 60 - 110 - 120 - 230 - 240		
V DC	6 - 12 - 24 - 48 - 60 - 110		
Rated power AC/DC VA (50 Hz)/W	1.5/1	1.5/1	1.5/1
Operating range AC (50 Hz)	(0.8...1.1)U <sub>N</sub>	(0.8...1.1)U <sub>N</sub>	(0.8...1.1)U <sub>N</sub>
DC	(0.8...1.1)U <sub>N</sub>	(0.8...1.1)U <sub>N</sub>	(0.8...1.1)U <sub>N</sub>
Holding voltage AC/DC	0.8 U <sub>N</sub> /0.5 U <sub>N</sub>	0.8 U <sub>N</sub> /0.5 U <sub>N</sub>	0.8 U <sub>N</sub> /0.5 U <sub>N</sub>
Must drop-out voltage AC/DC	0.2 U <sub>N</sub> /0.1 U <sub>N</sub>	0.2 U <sub>N</sub> /0.1 U <sub>N</sub>	0.2 U <sub>N</sub> /0.1 U <sub>N</sub>
<b>Technical data</b>			
Mechanical life AC/DC cycles	20 · 10 <sup>6</sup> /50 · 10 <sup>6</sup>	20 · 10 <sup>6</sup> /50 · 10 <sup>6</sup>	20 · 10 <sup>6</sup> /50 · 10 <sup>6</sup>
Electrical life at rated load AC1 cycles	200 · 10 <sup>3</sup>	200 · 10 <sup>3</sup>	150 · 10 <sup>3</sup>
Operate/release time (bounce included) ms	10/15	10/15	10/15
Insulation according to EN 61810-5	3.6 kV/2	3.6 kV/2	3.6 kV/2
Insulation between coil and contacts (1.2/50µs) kV	3.6	3.6	3.6
Dielectric strength between open contacts V AC	1,000	1,000	1,000
Ambient temperature range °C	-40...+70	-40...+70	-40...+70
Environmental protection	RT I	RT I	RT I
<b>Approvals:</b> (according to type)			



## ORDERING INFORMATION

Example: a 55 series plug-in relay, 4 CO contacts, coil rated 12 V DC with a lockable test button and mechanical indicator.

	<b>5</b>	<b>5</b>	<b>.</b>	<b>3</b>	<b>.</b>	<b>4</b>	<b>.</b>	<b>9</b>	<b>.</b>	<b>0</b>	<b>1</b>	<b>2</b>	<b>.</b>	<b>0</b>	<b>A</b>	<b>0</b>	<b>B</b>	<b>0</b>	<b>C</b>	<b>4</b>	<b>D</b>	<b>0</b>
--	----------	----------	----------	----------	----------	----------	----------	----------	----------	----------	----------	----------	----------	----------	----------	----------	----------	----------	----------	----------	----------	----------

**Series**

**Type**  
1 = P.C.B.  
3 = Plug-in

**No. of poles**  
2 = 2 pole, 10 A  
3 = 3 pole, 10 A  
4 = 4 pole, 5 A

**Coil version**  
8 = AC (50/60 Hz)  
9 = DC

**Coil voltage**  
see coil specifications

**A: Contact material**  
0 = Standard AgNi  
2 = AgCdO  
5 = AgNi + 5µm Au

**B: Contact circuit**  
0 = CO

**D: Special versions**  
0 = Standard  
1 = Wash tight (RT III)  
for 55.12, 55.13 and 55.14 only  
6 = Rear flange mount

**C: Options**  
0 = None  
1 = Lockable test button  
2 = Mechanical indicator  
3 = LED (AC)  
4 = Lockable test button + mechanical indicator  
5 = Lockable test button + LED (AC)  
54 = Lockable test button + LED (AC)  
+ mechanical indicator  
6 = LED + diode (positive to pin A2/14,  
DC non standard polarity)  
7 = Lockable test button + LED + diode (positive  
to pin A2/14, DC non standard polarity)  
74 = Lockable test button + LED + diode (positive  
to pin A2/14, DC non standard polarity)  
+ mechanical indicator  
8 = LED + diode (positive to pin A1/13,  
DC standard polarity)  
9 = Lockable test button + LED + diode (positive  
to pin A1/13, DC standard polarity)  
94 = Lockable test button + LED + diode (positive  
to pin A1/13, DC standard polarity)  
+ mechanical indicator

**Only combinations in the same row are possible**

Preferred versions

	coil version	A	B	C	D
55.32/34	AC/DC	0	0	4	0
55.12/13/14	AC/DC	0	0	0	0
55.33	AC/DC	0	0	0	0

All versions

	coil version	A	B	C	D
55.32/34	AC/DC	0 - 2 - 5	0	0	0 - 6
	AC	0 - 2 - 5	0	2 - 3 - 4 - 5	0 - 6
	AC	0 - 2 - 5	0	54	/
	DC	0 - 2 - 5	0	2 - 4 - 6 - 7 - 8 - 9	0 - 6
	DC	0 - 2 - 5	0	74 - 94	/
55.33	AC/DC	0 - 2 - 5	0	0	0 - 6
	AC	0 - 2 - 5	0	1 - 3 - 5	0 - 6
	DC	0 - 2 - 5	0	1 - 6 - 7 - 8 - 9	0 - 6
55.12/13/14	AC/DC	0 - 2 - 5	0	0	0 - 1

## POSSIBLE OPTIONS

AC
DC - Non standard polarity
DC - Standard polarity

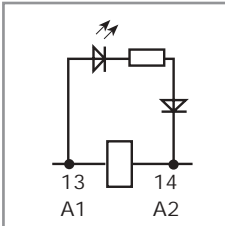

Option = 0030  
0050  
0054

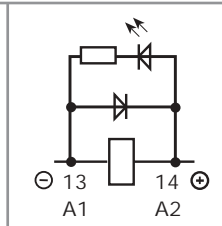

Option = 0060  
0070  
0074

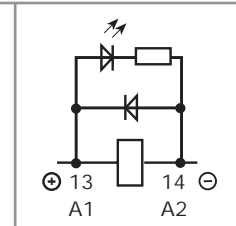

Option = 0080  
0090  
0094

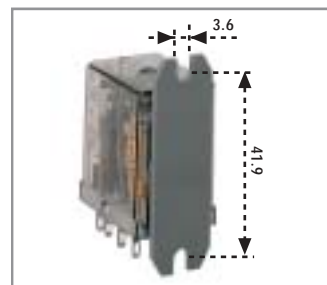

Option = 0006  
REAR FLANGE MOUNT



**LOCKABLE TEST BUTTON AND MECHANICAL FLAG INDICATOR (0040)**

The dual-purpose Finder test button can be used in two ways:

**Case 1)** The plastic pip (located directly above the test button) remains intact. In this case, when the test button is pushed, the contacts operate. When the test button is released the contacts return to their former state.

**Case 2)** The plastic pip is broken-off (using an appropriate cutting tool). In this case, (in addition to the above function), when the test button is pushed and rotated, the contacts are latched in the operating state, and remain so until the test button is rotated back to its former position.

In both cases ensure that the test button actuation is swift and decisive.

## TECHNICAL DATA

### INSULATION

INSULATION according to EN 61810-5	insulation rated voltage	V	250
	rated impulse withstand voltage	kV	3.6
	pollution degree		2
	overvoltage category		III

### IMMUNITY

CONDUCTED DISTURBANCE IMMUNITY	BURST (according to EN 61000-4-4) level 4 (4 kV)
	SURGE (according to EN 61000-4-5) level 4 (4 kV)

### OTHER DATA

VIBRATION RESISTANCE (10...55Hz): NO/NC	g/g	6/6			
POWER LOST TO THE ENVIRONMENT		2 CO	3 CO	4 CO	
	without contact current	W	1	1	1
	with rated current	W	3	4	2.6
RECOMMENDED DISTANCE between RELAYS mounted on P.C.B.s	mm	≥5			

55

## CONTACT SPECIFICATIONS

### F 55

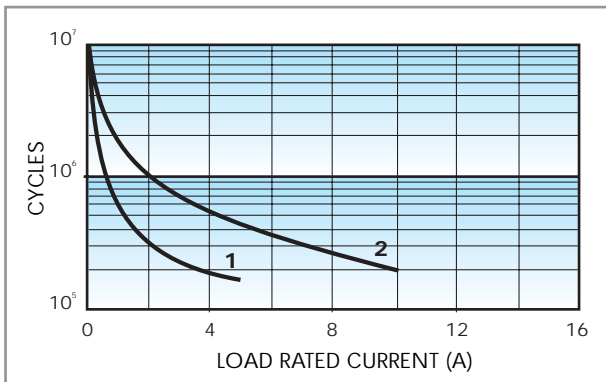

Electrical life vs AC1 load.  
**1** = 4 CO relay type (5 A).  
**2** = 2 · 3 CO relay type (10 A).

### H 55

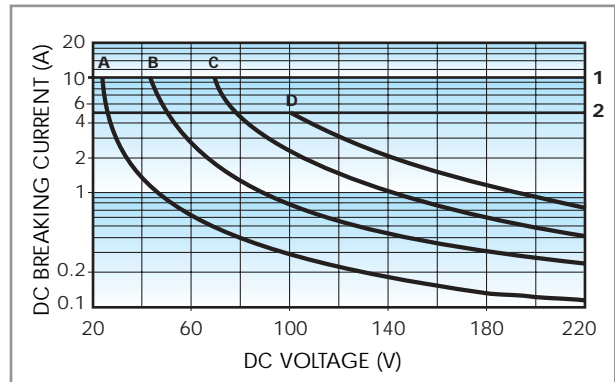

Breaking capacity for DC1 load.  
**1** = 2 · 3 CO type.  
**2** = 4 CO type.  
**A** = Load applied to 1 contact  
**B** = Load applied to 2 contacts in series  
**C** = Load applied to 3 contacts in series  
**D** = Load applied to 4 contacts in series

- When switching a resistive load (DC1) having voltage and current values under the curve the expected electrical life is  $\geq 100 \cdot 10^3$  cycles.
  - In case of DC13 loads the connection of a diode in parallel with the load will permit the same electrical life as for a DC1 load.
- Note:** the release time of load will be increase.

## COIL SPECIFICATIONS

### AC VERSION DATA

Nominal voltage $U_N$ V	Coil code	Operating range		Resistance R $\Omega$	Rated coil consumption I at $U_N$ (50Hz) mA
		$U_{min}$ V	$U_{max}$ V		
6	8.006	4.8	6.6	12	200
12	8.012	9.6	13.2	50	97
24	8.024	19.2	26.4	190	53
48	8.048	38.4	52.8	770	25
60	8.060	48	66	1,200	21
110	8.110	88	121	4,000	12.5
120	8.120	96	132	4,700	12
230	8.230	184	253	17,000	6
240	8.240	192	264	19,100	5.3

### DC VERSION DATA

Nominal voltage $U_N$ V	Coil code	Operating range		Resistance R $\Omega$	Rated coil consumption I at $U_N$ mA
		$U_{min}$ V	$U_{max}$ V		
6	9.006	4.8	6.6	40	150
12	9.012	9.6	13.2	140	86
24	9.024	19.2	26.4	600	40
48	9.048	38.4	52.8	2,400	20
60	9.060	48	66	4,000	15
110	9.110	88	121	12,500	8.8

### R 55 AC

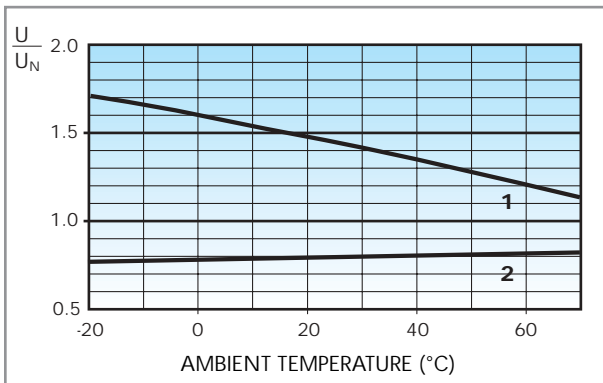

Operating range (AC type) vs ambient temperature.  
**1** - Max coil voltage permitted.  
**2** - Min pick-up voltage with coil at ambient temperature.

### R 55 DC

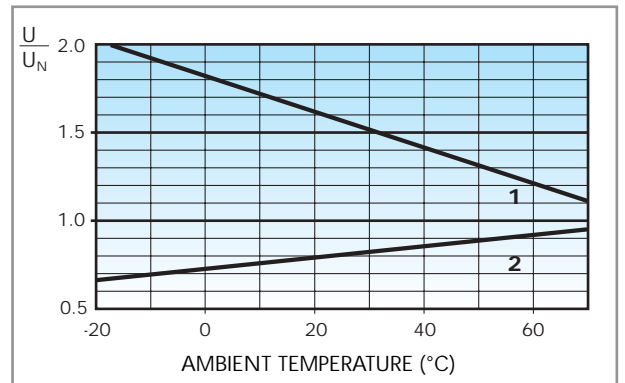

Operating range (DC type) vs ambient temperature.  
**1** - Max coil voltage permitted.  
**2** - Min pick-up voltage with coil at ambient temperature.



94.04

Approvals  
(according to type):



Relay type	55.32		55.33		55.32, 55.34	
	BLUE	BLACK	BLUE	BLACK	BLUE	BLACK
Colour	BLUE	BLACK	BLUE	BLACK	BLUE	BLACK
Clamp terminal socket: panel or 35 mm rail (EN 50022) mount retaining clip 094.71 supplied with socket packaging code SMA	94.02	94.02.0	94.03	94.03.0	94.04	94.04.0
Metal retaining clip	094.71					
Plastic retaining and release clip	094.01					
6-way jumper link for 94.02, 94.03 and 94.04 sockets	094.06	094.06.0	094.06	094.06.0	094.06	094.06.0
Identification tag	094.00.4					
Modules (see table below)	99.02					
Timer modules	86.10, 86.20					
Sheet of marker tags for retaining and release clip 094.01	060.72					

- RATED VALUES: 10 A - 250 V
- DIELECTRIC STRENGTH: ≥ 2 kV AC
- PROTECTION CATEGORY: IP 20
- AMBIENT TEMPERATURE: (-40...+70)°C
- SCREW TORQUE: 0.5 Nm
- WIRE STRIP LENGTH: 8 mm
- MAX WIRE SIZE:

55

	solid wire	stranded wire
mm <sup>2</sup>	1x6 / 2x2.5	1x4 / 2x2.5
AWG	1x10 / 2x14	1x12 / 2x14

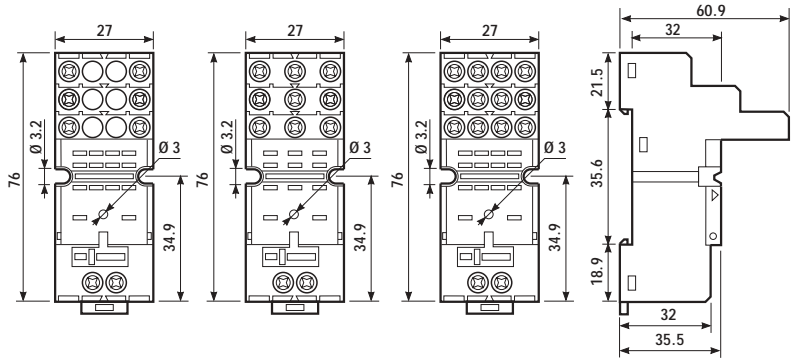

094.01

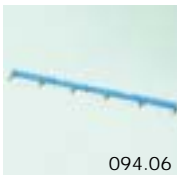
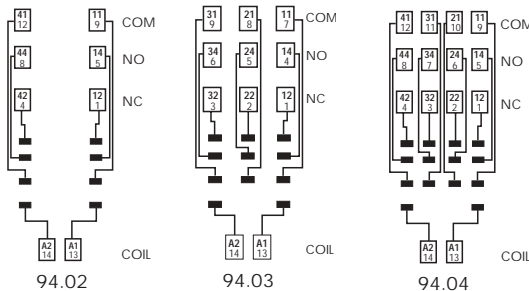

094.06

6-way jumper link for 94.02, 94.03 and 94.04 sockets	094.06
--	--------

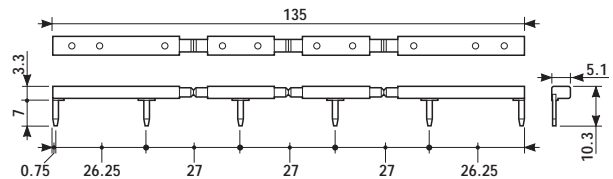

- RATED VALUES: 10 A - 250 V



99.02

99.02 modules for 94.02, 94.03 and 94.04 sockets		BLUE
Diode** (+A1)	(6...220) V DC	99.02.3.000.00
Diode (inverted polarity)	(6...220) V DC	99.02.2.000.00
LED	(6...24) V DC/AC	99.02.0.024.59
LED	(28...60) V DC/AC	99.02.0.060.59
LED	(110...240) V DC/AC	99.02.0.230.59
LED + Diode** (+A1)	(6...24) V DC	99.02.9.024.99
LED + Diode** (+A1)	(28...60) V DC	99.02.9.060.99
LED + Diode** (+A1)	(110...220) V DC	99.02.9.220.99
LED + Diode (inverted polarity)	(6...24) V DC	99.02.9.024.79
LED + Diode (inverted polarity)	(28...60) V DC	99.02.9.060.79
LED + Diode (inverted polarity)	(110...220) V DC	99.02.9.220.79
LED + Varistor	(6...24) V DC/AC	99.02.0.024.98
LED + Varistor	(28...60) V DC/AC	99.02.0.060.98
LED + Varistor	(110...240) V DC/AC	99.02.0.230.98
RC circuit	(6...24) V DC/AC	99.02.0.024.09
RC circuit	(28...60) V DC/AC	99.02.0.060.09
RC circuit	(110...240) V DC/AC	99.02.0.230.09
No - remanence (62 kΩ/1W)	(110...240) V AC	99.02.8.230.07

\*\*For DC supply, apply the positive to terminal A1. Modules in Black housing are available on request.



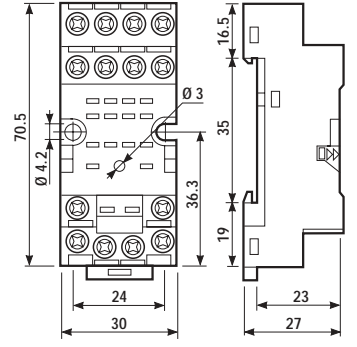
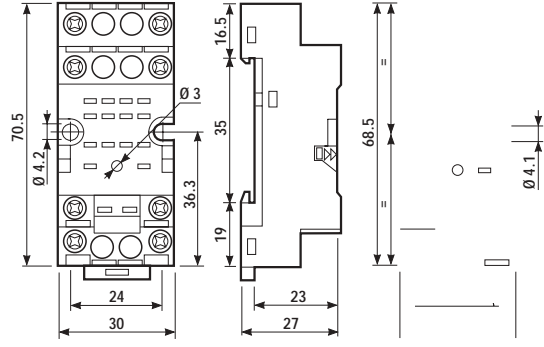



94.84.1

Approvals  
(according to type):



- RATED VALUES: 10 A - 250 V
- DIELECTRIC STRENGTH:  $\geq 2$  kV AC
- PROTECTION CATEGORY: IP 20
- AMBIENT TEMPERATURE: (-40...+70)°C
- SCREW TORQUE: 0.5 Nm
- WIRE STRIP LENGTH: 7 mm
- MAX WIRE SIZE:

55

	solid wire	stranded wire
mm <sup>2</sup>	1x6 / 2x2.5	1x4 / 2x2.5
AWG	1x10 / 2x14	1x12 / 2x14

Relay type	55.32, 55.34	
Colour	BLUE	BLACK
<b>Clamp terminal socket:</b> panel or 35 mm rail (EN 50022) mount retaining clip 094.71 supplied with socket packaging code SMA	94.84.1	94.84.10
Retaining clip	094.71	
Plastic retaining and release clip	094.91	
Identification tag	094.80.2	
Modules (see table below)	99.80	

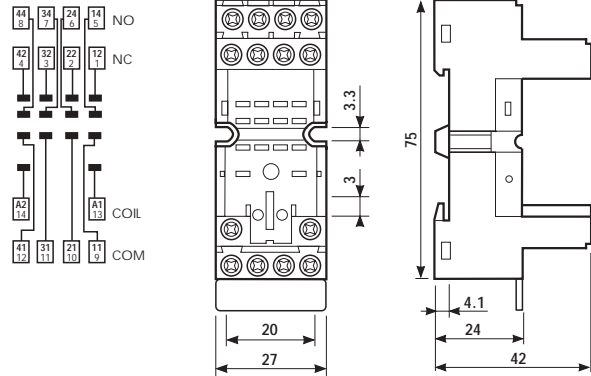

99.80

99.80 modules for 94.84.1 sockets		BLUE
Diode** (+A1)	(6...220) V DC	99.80.3.000.00
LED	(6...24) V DC/AC	99.80.0.024.59
LED	(28...60) V DC/AC	99.80.0.060.59
LED	(110...240) V DC/AC	99.80.0.230.59
LED + Diode** (+A1)	(6...24) V DC	99.80.9.024.99
LED + Diode** (+A1)	(28...60) V DC	99.80.9.060.99
LED + Diode** (+A1)	(110...220) V DC	99.80.9.220.99
LED + Varistor	(6...24) V DC/AC	99.80.0.024.98
LED + Varistor	(28...60) V DC/AC	99.80.0.060.98
LED + Varistor	(110...240) V DC/AC	99.80.0.230.98
RC circuit	(6...24) V DC/AC	99.80.0.024.09
RC circuit	(28...60) V DC/AC	99.80.0.060.09
RC circuit	(110...240) V DC/AC	99.80.0.230.09
No - remanence (62 kΩ/1W)	(110...240) V AC	99.80.8.230.07

\*\*For DC supply, apply the positive to terminal A1. Modules in Black housing are available on request. Green LED is standard. Red LED available on request.



94.14

Approvals  
(according to type):



- RATED VALUES: 10 A - 250 V
- DIELECTRIC STRENGTH:  $\geq 2$  kV AC
- AMBIENT TEMPERATURE: (-40...+70)°C

Relay type	55.32		55.33		55.32, 55.34	
Colour	BLUE	BLACK	BLUE	BLACK	BLUE	BLACK
<b>P.C.B. socket</b>	94.12	94.12.0	94.13	94.13.0	94.14	94.14.0
retaining clip 094.51 supplied with socket packaging code SMA						
Metal retaining clip	094.51					

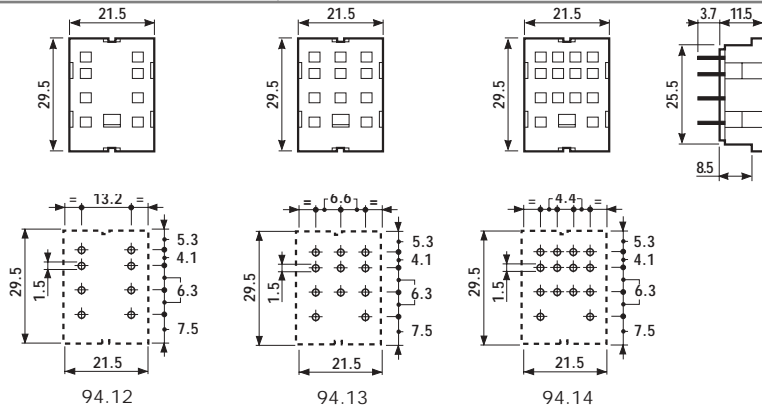

Copper side view





- Plug-in or P.C.B. versions
- AC or DC coils
- Lockable test button and mechanical flag indicator as standard on 2 CO relay type
- Sockets and accessories: see 96, and 99 series

## 56.32

## 56.32 - 0300

## 56.34

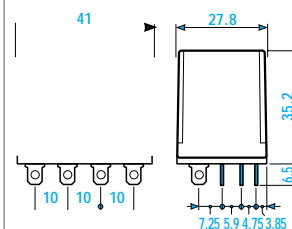
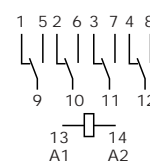
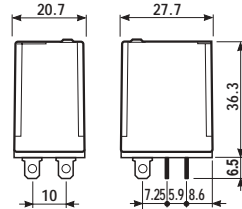
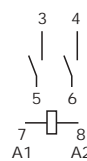
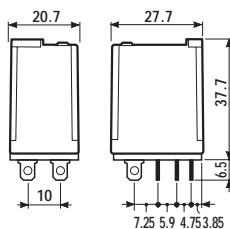
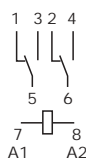

\* for 400 V applications, requirements for pollution degree 2 are met.

Contact specifications		56.32	56.32 - 0300	56.34
Contact configuration		2 CO	2 NO 1.5 mm	4 CO
Rated current/Maximum peak current	A	12/20	12/20	12/20
Rated voltage/Maximum switching voltage	V AC	250/400*	250/400*	250/400*
Rated load in AC1	VA	3,000	3,000	3,000
Rated load in AC15 (230 VAC)	VA	500	500	500
Single phase motor rating (230 VAC)	kW	0.55	0.55	0.55
Breaking capacity in DC1: 30/110/220V	A	12/0.25/0.12	12/0.6/0.3	12/0.25/0.12
Minimum switching load	mW (V/mA)	500 (10/5)	500 (10/5)	500 (10/5)
Standard contact material		AgNi	AgNi	AgNi
Coil specifications		56.32	56.32 - 0300	56.34
Nominal voltage (U <sub>N</sub> )	V AC (50/60 Hz)	6 - 12 - 24 - 48 - 60 - 110 - 120 - 230 - 240		
	V DC	6 - 12 - 24 - 48 - 60 - 110	—	6 - 12 - 24 - 48 - 60 - 110
Rated power AC/DC	VA (50 Hz)/W	1.5/1	1.5/—	2/1.3
Operating range	AC (50 Hz)	(0.8...1.1)U <sub>N</sub>	(0.8...1.1)U <sub>N</sub>	(0.8...1.1)U <sub>N</sub>
	DC	(0.85...1.1)U <sub>N</sub>	—	(0.85...1.1)U <sub>N</sub>
Holding voltage	AC/DC	0.8 U <sub>N</sub> /0.6 U <sub>N</sub>	0.8 U <sub>N</sub> /—	0.8 U <sub>N</sub> /0.6 U <sub>N</sub>
Must drop-out voltage	AC/DC	0.2 U <sub>N</sub> /0.1 U <sub>N</sub>	0.2 U <sub>N</sub> /—	0.2 U <sub>N</sub> /0.1 U <sub>N</sub>
Technical data		56.32	56.32 - 0300	56.34
Mechanical life AC/DC	cycles	20 · 10 <sup>6</sup> /50 · 10 <sup>6</sup>	20 · 10 <sup>6</sup> /—	20 · 10 <sup>6</sup> /50 · 10 <sup>6</sup>
Electrical life at rated load AC1	cycles	200 · 10 <sup>3</sup>	200 · 10 <sup>3</sup>	150 · 10 <sup>3</sup>
Operate/release time (bounce included)	ms	10/15	20/—	15/15
Insulation according to EN 61810-5		4 kV/3	4 kV/3	4 kV/3
Insulation between coil and contacts (1.2/50μs)	kV	4	4	4
Dielectric strength between open contacts	V AC	1,000	2,000	1,000
Ambient temperature range	°C	-40...+70	-40...+70	-40...+70
Environmental protection		RT I	RT I	RT I
Approvals: (according to type)				

- Plug-in or P.C.B. versions
- AC or DC coils
- Lockable test button and mechanical flag indicator as standard on 2 CO relay type
- Sockets and accessories: see 96, and 99 series

### 56.42

### 56.42 - 0300

### 56.44



- 2 pole  
- P.C.B. mounting

- 2 NO (1.5 mm gap)  
- P.C.B. mounting

- 4 pole  
- P.C.B. mounting

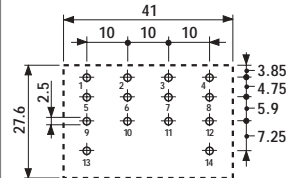
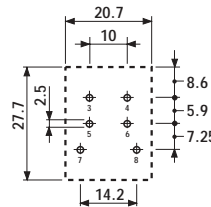
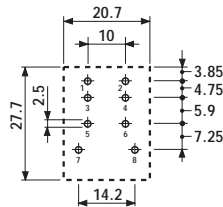
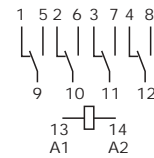
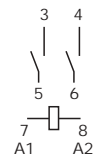
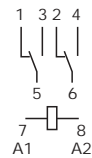

Copper side view  
h = 37.7 mm

Copper side view  
h = 36.3 mm

Copper side view  
h = 35.2 mm

\* for 400 V applications, requirements for pollution degree 2 are met.

Contact specifications				
Contact configuration		2 CO	2 NO 1.5 mm	4 CO
Rated current/Maximum peak current	A	12/20	12/2	12/20
Rated voltage/Maximum switching voltage	V AC	250/400*	250/400*	250/400*
Rated load in AC1	VA	3,000	3,000	3,000
Rated load in AC15 (230 VAC)	VA	500	500	500
Single phase motor rating (230 VAC)	kW	0.55	0.55	0.55
Breaking capacity in DC1: 30/110/220V	A	12/0.25/0.12	12/0.6/0.3	12/0.25/0.12
Minimum switching load	mW (V/mA)	500 (10/5)	500 (10/5)	500 (10/5)
Coil specifications				
Nominal voltage (U <sub>N</sub> )	V AC (50/60 Hz)	6 - 12 - 24 - 48 - 60 - 110 - 120 - 230 - 240		
	V DC	6 - 12 - 24 - 48 - 60 - 110	—	6 - 12 - 24 - 48 - 60 - 110
Rated power AC/DC	VA (50 Hz)/W	1.5/1	1.5/—	2/1.3
Operating range	AC (50 Hz)	(0.8...1.1)U <sub>N</sub>		
	DC	(0.85...1.1)U <sub>N</sub>	—	(0.85...1.1)U <sub>N</sub>
Holding voltage	AC/DC	0.8 U <sub>N</sub> /0.6 U <sub>N</sub>	0.8 U <sub>N</sub> /—	0.8 U <sub>N</sub> /0.6 U <sub>N</sub>
Must drop-out voltage	AC/DC	0.2 U <sub>N</sub> /0.1 U <sub>N</sub>	0.2 U <sub>N</sub> /0.1 U <sub>N</sub>	0.2 U <sub>N</sub> /0.1 U <sub>N</sub>
Technical data				
Mechanical life AC/DC	cycles	20 · 10 <sup>6</sup> /50 · 10 <sup>6</sup>	20 · 10 <sup>6</sup> /—	20 · 10 <sup>6</sup> /50 · 10 <sup>6</sup>
Electrical life at rated load AC1	cycles	200 · 10 <sup>3</sup>	200 · 10 <sup>3</sup>	150 · 10 <sup>3</sup>
Operate/release time (bounce included)	ms	10/15	20/—	15/15
Insulation according to EN 61810-5		4 kV/3	4 kV/3	4 kV/3
Insulation between coil and contacts (1.2/50µs)	kV	4	4	4
Dielectric strength between open contacts	V AC	1,000	2,000	1,000
Ambient temperature range	°C	-40...+70	-40...+70	-40...+70
Environmental protection		RT I	RT I	RT I
Approvals: (according to type)		CE	SP	UL <sup>®</sup> US

## ORDERING INFORMATION

Example: a 56 series plug-in relay with 2 CO contacts, coil rated 12 V DC with a lockable test button and mechanical indicator.

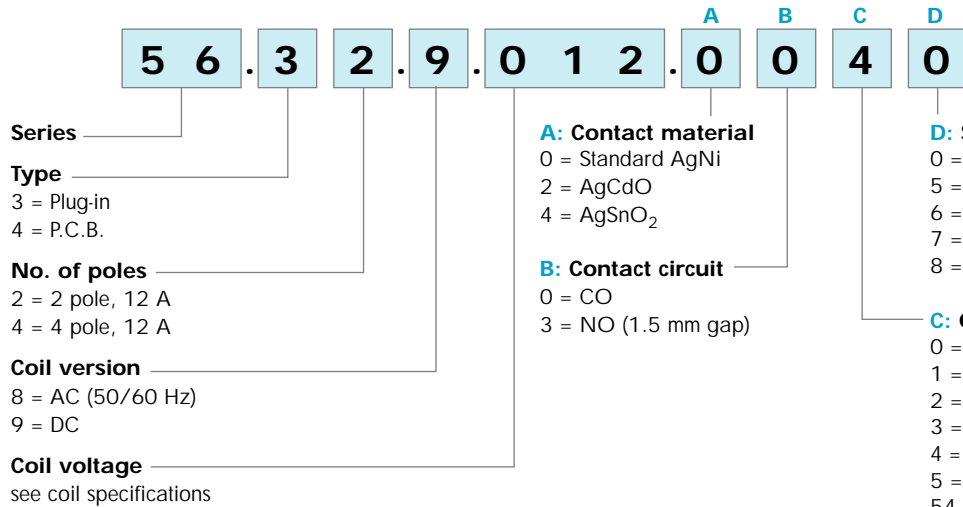

56

Only combinations in the same row are possible

Preferred versions

	coil version	A	B	C	D
56.32	AC/DC	0	0	4	0
56.34	AC/DC	0	0	0	0
56.42	AC/DC	0	0	0	0
56.44	AC/DC	0	0	0	0

All versions

	coil version	A	B	C	D
56.32	AC	0 - 2 - 4	0	0 - 2 - 3 - 4 - 5	0 - 6
	AC	0 - 2 - 4	0	54	/
	AC	0 - 2 - 4	3	0 - 3 - 5	0 - 6
	DC	0 - 2 - 4	0	0 - 2 - 4 - 6 - 7 - 8 - 9	0 - 6
	DC	0 - 2 - 4	0	74 - 94	/
56.34	AC/DC	0 - 2 - 4	0	0 - 1	0 - 5 - 6 - 7 - 8
56.42	AC/DC	0 - 2 - 4	0	0	0
	AC	0 - 2 - 4	3	0	0
56.44	AC/DC	0 - 2 - 4	0	0	0

- D: Special versions**  
 0 = Standard  
 5 = Top flange mount (56.34 only)  
 6 = Rear flange mount  
 7 = Top 35mm rail mount (56.34 only)  
 8 = Rear 35mm rail mount (56.34 only)
- C: Options**  
 0 = None  
 1 = Test button  
 2 = Mechanical indicator  
 3 = LED (AC only)  
 4 = Lockable test button + mechanical indicator  
 5 = Lockable test button + LED (AC only)  
 54 = Lockable test button + LED (AC only) + mechanical indicator  
 6 = LED (AC only) + diode (polarity positive to pin A2/8, DC non standard)  
 7 = Lockable test button + LED + diode (polarity positive to pin A2/8, DC non standard)  
 74 = Lockable test button + LED + diode (polarity positive to pin A2/8, DC non standard) + mechanical indicator  
 8 = LED + diode (polarity positive to pin 7, DC)  
 9 = Lockable test button + LED + diode (polarity positive to pin 7, DC)  
 94 = Lockable test button + LED + diode + mechanical indicator (polarity positive to pin 7, DC)

## POSSIBLE OPTIONS

AC

DC - Non standard polarity

DC - Standard polarity

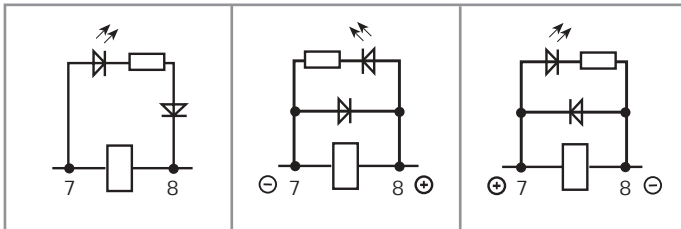

Option = 0030  
0050

Option = 0060  
0070  
0074

Option = 0080  
0090  
0094

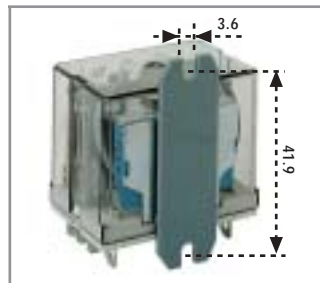

Option = 0006  
REAR FLANGE MOUNT

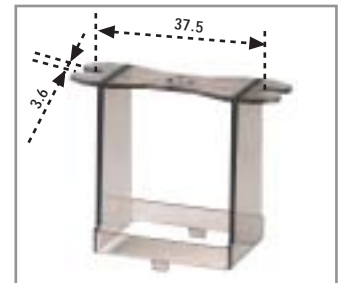

Type 056.05 - ADAPTOR WITH TOP FLANGE MOUNT (for 56.32...XX00)

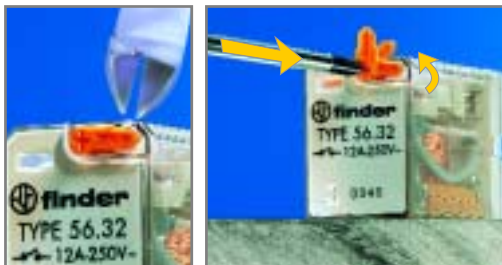

### LOCKABLE TEST BUTTON AND MECHANICAL FLAG INDICATOR (0040)

The dual-purpose Finder test button can be used in two ways:

Case 1 The plastic pip (located directly above the test button) remains intact. In this case, when the test button is pushed, the contacts operate. When the test button is released the contacts return to their former state.

Case 2 The plastic pip is broken-off (using an appropriate cutting tool). In this case, (in addition to the above function), when the test button is pushed and rotated, the contacts are latched in the operating state, and remain so until the test button is rotated back to its former position.

In both cases ensure that the test button actuation is swift and decisive.

## TECHNICAL DATA

### INSULATION

INSULATION according to EN 61810-5	insulation rated voltage	V	250
	rated impulse withstand voltage	kV	4
	pollution degree		3
	overvoltage category		III

### IMMUNITY

CONDUCTED DISTURBANCE IMMUNITY	BURST (according to EN 61000-4-4) level 4 (4 kV)
	SURGE (according to EN 61000-4-5) level 4 (4 kV)

### OTHER DATA

VIBRATION RESISTANCE (10...55Hz): NO/NC	g/g	8/8	
POWER LOST TO THE ENVIRONMENT	<b>2 CO / 2 NO</b>	<b>4 CO</b>	
	without contact current W	1	1.3
	with rated current W	3.8	6.9
RECOMMENDED DISTANCE between RELAYS mounted on P.C.B.s	mm	≥5	

## CONTACT SPECIFICATIONS

### F 56

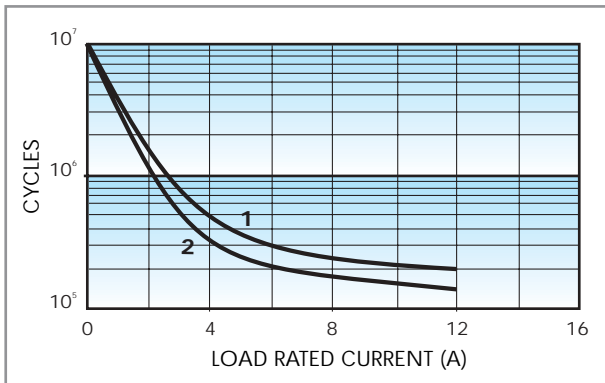

Electrical life vs AC1 load.

**1** = Types 56.32/42

**2** = Types 56.34/44

### H 56 (CO)

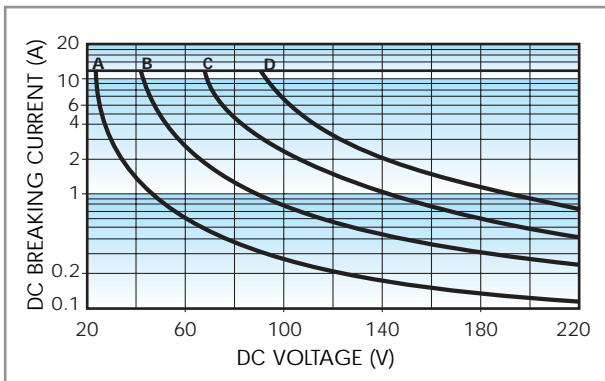

Breaking capacity for DC1 load.

**A** = Load applied to 1 contact.

**B** = Load applied to 2 contacts in series.

**C** = Load applied to 3 contacts in series.

**D** = Load applied to 4 contacts in series.

- When switching a resistive load (DC1) having voltage and current values under the curve the expected electrical life is  $\geq 100 \cdot 10^3$  cycles.

- In case of DC13 loads the connection of a diode in parallel with the load will permit the same electrical life as for a DC1 load.

**Note:** the release time of load will be increase.

### H 56 (NO)

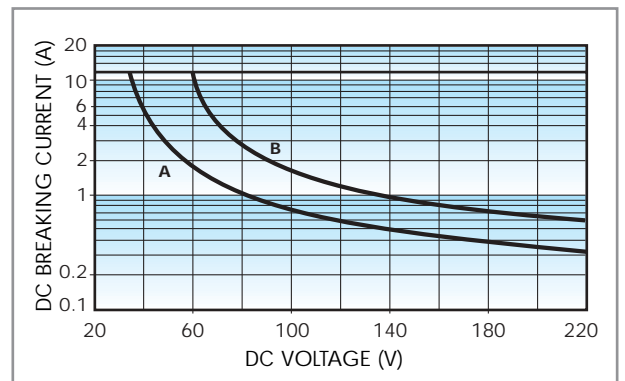

Breaking capacity for DC1 load.

**A** = Load applied to 1 contact.

**B** = Load applied to 2 contacts in series.

- When switching a resistive load (DC1) having voltage and current values under the curve the expected electrical life is  $\geq 100 \cdot 10^3$  cycles.

- In case of DC13 loads the connection of a diode in parallel with the load will permit the same electrical life as for a DC1 load.

**Note:** the release time of load will be increase.

## COIL SPECIFICATIONS

### AC VERSION DATA (2 CO, 2 NO)

Nominal voltage $U_N$ V	Coil code	Operating range		Resistance R $\Omega$	Rated coil consumption I at $U_N$ (50Hz) mA
		$U_{min}$ V	$U_{max}$ V		
6	8.006	4.8	6.6	12	200
12	8.012	9.6	13.2	50	97
24	8.024	19.2	26.4	190	53
48	8.048	38.4	52.8	770	25
60	8.060	48	66	1,200	21
110	8.110	88	121	3,940	12.5
120	8.120	96	132	4,700	12
230	8.230	184	253	17,000	6
240	8.240	192	264	19,100	5.3

### DC VERSION DATA (2 CO)

Nominal voltage $U_N$ V	Coil code	Operating range		Resistance R $\Omega$	Rated coil consumption I at $U_N$ mA
		$U_{min}$ V	$U_{max}$ V		
6	9.006	5.1	6.6	40	150
12	9.012	10.2	13.2	140	86
24	9.024	20.4	26.4	600	40
48	9.048	40.8	52.8	2,400	20
60	9.060	51	66	4,000	15
110	9.110	93.5	121	12,500	8.8

### 56 AC VERSION DATA (4 CO)

Nominal voltage $U_N$ V	Coil code	Operating range		Resistance R $\Omega$	Rated coil consumption I at $U_N$ (50Hz) mA
		$U_{min}$ V	$U_{max}$ V		
6	8.006	4.8	6.6	5.7	300
12	8.012	9.6	13.2	22	150
24	8.024	19.2	26.4	81	90
48	8.048	38.4	52.8	380	37
60	8.060	48	66	600	30
110	8.110	88	121	1,900	16.5
120	8.120	96	132	2,560	13.4
230	8.230	184	253	7,700	9
240	8.240	192	264	10,000	7.5

### DC VERSION DATA (4 CO)

Nominal voltage $U_N$ V	Coil code	Operating range		Resistance R $\Omega$	Rated coil consumption I at $U_N$ mA
		$U_{min}$ V	$U_{max}$ V		
6	9.006	5.1	6.6	32.5	185
12	9.012	10.2	13.2	123	97
24	9.024	20.4	26.4	490	49
48	9.048	40.8	52.8	1,800	27
60	9.060	51	66	3,000	20
110	9.110	93.5	121	10,400	10.5

### R 56 AC (2 co, 2 no)

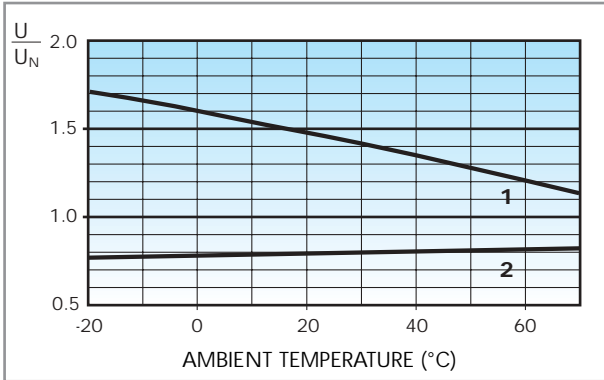

### R 56 DC (2 co)

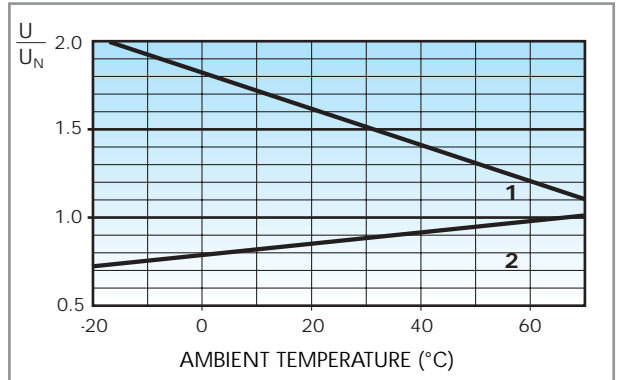

### R 56 AC (4 co)

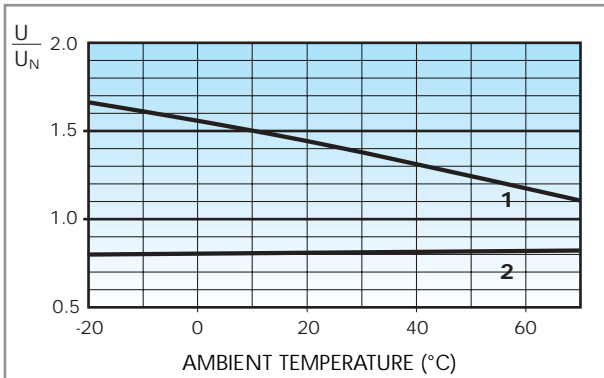

### R 56 DC (4 co)

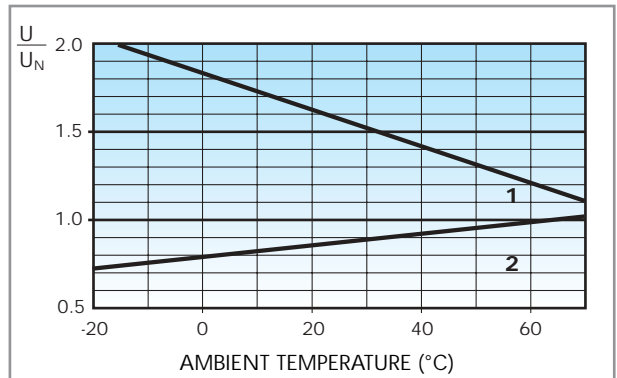

Operating range (AC type) vs ambient temperature.

**1** - Max coil voltage permitted.

**2** - Min pick-up voltage with coil at ambient temperature.

Operating range (DC type) vs ambient temperature.

**1** - Max coil voltage permitted.

**2** - Min pick-up voltage with coil at ambient temperature.





Relay type	56.32		56.34	
Colour	BLUE	BLACK	BLUE	BLACK
Screw terminal socket: panel or 35 mm rail (EN 50022) mount retaining clip 094.71/096.71 supplied with socket packaging code SMA	96.72	96.72.0	96.74	96.74.0
Retaining clip	094.71		096.71	
Modules (see table below)	99.01			

Approvals  
(according to type):



- RATED VALUES: 12 A - 250 V
- DIELECTRIC STRENGTH:  $\geq 2$  kV AC
- PROTECTION CATEGORY: IP 20
- AMBIENT TEMPERATURE: (-40...+70)°C
- SCREW TORQUE: 0.8 Nm
- WIRE STRIP LENGTH: 10 mm
- MAX WIRE SIZE:

	solid wire	stranded wire
mm <sup>2</sup>	1x4 / 2x4	1x4 / 2x2.5
AWG	1x12 / 2x12	1x12 / 2x14

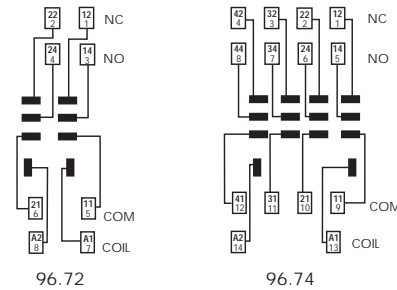
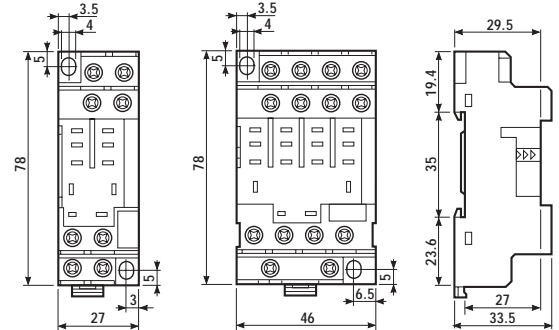

99.01 modules for 96.72 and 96.74 socket		BLUE
Diode** (+A1)	(6...220) V DC	99.01.3.000.00
Diode (inverted polarity)	(6...220) V DC	99.01.2.000.00
LED	(6...24) V DC/AC	99.01.0.024.59
LED	(28...60) V DC/AC	99.01.0.060.59
LED	(110...240) V DC/AC	99.01.0.230.59
LED + Diode** (+A1)	(6...24) V DC	99.01.9.024.99
LED + Diode** (+A1)	(28...60) V DC	99.01.9.060.99
LED + Diode** (+A1)	(110...220) V DC	99.01.9.220.99
LED + Diode (inverted polarity)	(6...24) V DC	99.01.9.024.79
LED + Diode (inverted polarity)	(28...60) V DC	99.01.9.060.79
LED + Diode (inverted polarity)	(110...220) V DC	99.01.9.220.79
LED + Varistor	(6...24) V DC/AC	99.01.0.024.98
LED + Varistor	(28...60) V DC/AC	99.01.0.060.98
LED + Varistor	(110...240) V DC/AC	99.01.0.230.98
RC circuit	(6...24) V DC/AC	99.01.0.024.09
RC circuit	(28...60) V DC/AC	99.01.0.060.09
RC circuit	(110...240) V DC/AC	99.01.0.230.09
No - remanence (62 kΩ/1W)	(110...240) V AC	99.01.8.230.07

\*\*For DC supply, apply the positive to terminal A1. Modules in Black housing are available on request. Green LED is standard. Red LED available on request.

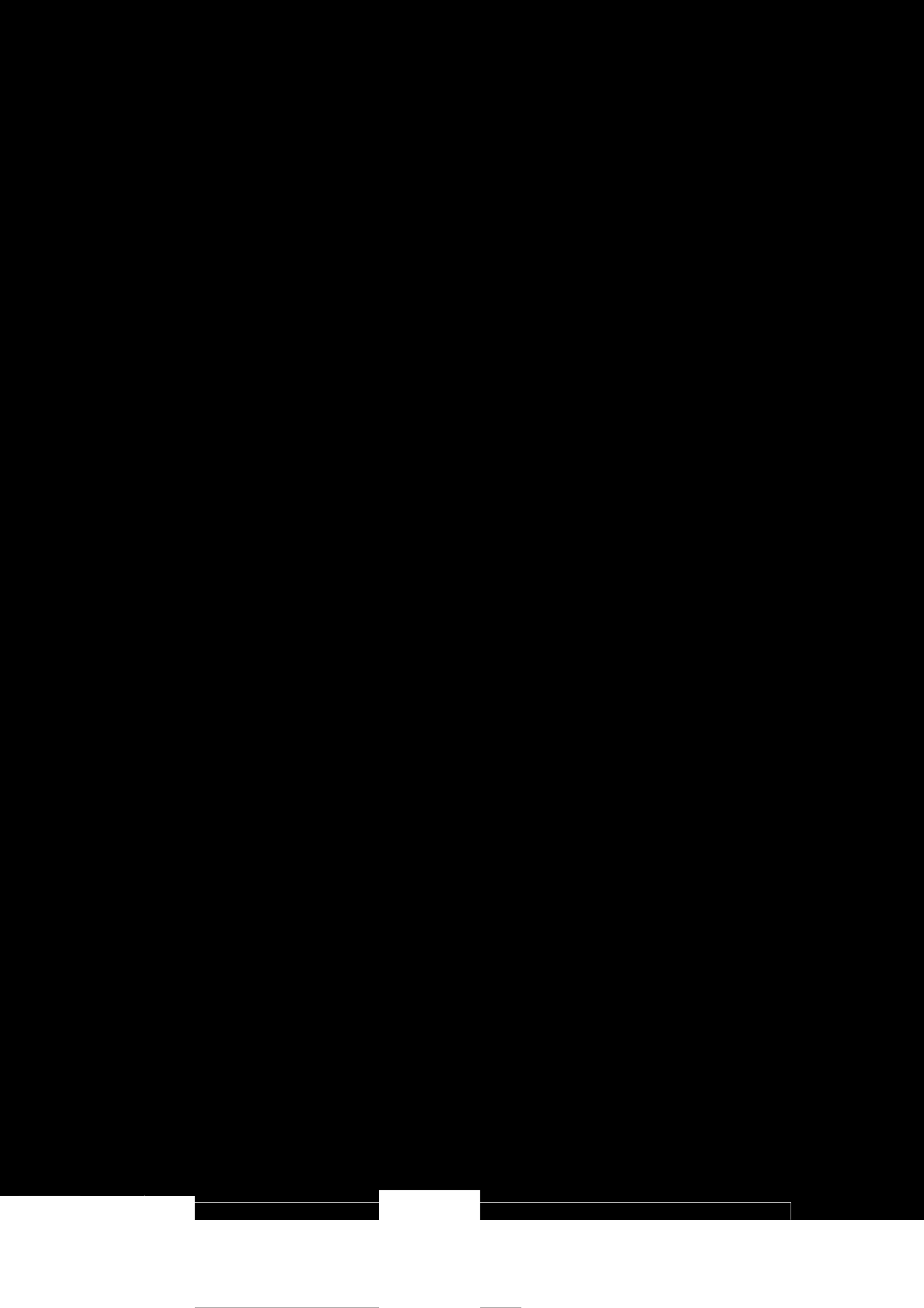

- 8 - 11 pin plug-in
- AC or DC coils
- Lockable test button with mechanical flag indicator
- Bifurcated contact option
- Sockets and accessories: see 90, 99 and 86 series

	60.12	60.12 - 0200	60.13
	<ul style="list-style-type: none"> <li>- 2 pole</li> <li>- 8 pin</li> <li>- Plug-In for use with 90 series sockets</li> </ul>	<ul style="list-style-type: none"> <li>- 2 bifurcated contacts</li> <li>- 8 pin</li> <li>- Plug-In for use with 90 series sockets</li> </ul>	<ul style="list-style-type: none"> <li>- 3 pole</li> <li>- 11 pin</li> <li>- Plug-In for use with 90 series sockets</li> </ul>
<b>Contact specifications</b>			
Contact configuration	2 CO	2 CO	3 CO
Rated current/Maximum peak current      A	10/20	6/10	10/20
Rated voltage/Maximum switching voltage V AC	250/400*	250/400*	250/400*
Rated load in AC1                                      VA	2,500	1,500	2,500
Rated load in AC15 (230 VAC)                      VA	500	250	500
Single phase motor rating (230 VAC)           kW	0.37	0.185	0.37
Breaking capacity in DC1: 30/110/220V      A	10/0.4/0.15	6/0.3/0.12	10/0.4/0.15
Minimum switching load                            mW (V/mA)	500 (10/5)	50 (5/5)	500 (10/5)
Standard contact material	AgNi	AgNi bifurcated contacts	AgNi
<b>Coil specifications</b>			
Nominal voltage (U <sub>N</sub> )	V AC (50/60 Hz)	6 - 12 - 24 - 48 - 60 - 110 - 120 - 230 - 240	
	V DC	6 - 12 - 24 - 48 - 60 - 110	
Rated power AC/DC                                  VA (50 Hz)/W	2.2/1.3	2.2/1.3	2.2/1.3
Operating range	AC (50 Hz)	(0.8...1.1)U <sub>N</sub>	(0.8...1.1)U <sub>N</sub>
	DC	(0.8...1.1)U <sub>N</sub>	(0.8...1.1)U <sub>N</sub>
Holding voltage                                      AC/DC	0.8 U <sub>N</sub> /0.5 U <sub>N</sub>	0.8 U <sub>N</sub> /0.5 U <sub>N</sub>	0.8 U <sub>N</sub> /0.5 U <sub>N</sub>
Must drop-out voltage                                AC/DC	0.2 U <sub>N</sub> /0.1 U <sub>N</sub>	0.2 U <sub>N</sub> /0.1 U <sub>N</sub>	0.2 U <sub>N</sub> /0.1 U <sub>N</sub>
<b>Technical data</b>			
Mechanical life AC/DC                            cycles	20 · 10 <sup>6</sup> /50 · 10 <sup>6</sup>	20 · 10 <sup>6</sup> /50 · 10 <sup>6</sup>	20 · 10 <sup>6</sup> /50 · 10 <sup>6</sup>
Electrical life at rated load AC1                cycles	200 · 10 <sup>3</sup>	250 · 10 <sup>3</sup>	200 · 10 <sup>3</sup>
Operate/release time (bounce included)      ms	15/15	15/15	15/15
Insulation according to EN 61810-5	3.6 kV/3	3.6 kV/3	3.6 kV/3
Insulation between coil and contacts (1.2/50µs) kV	3.6	3.6	3.6
Dielectric strength between open contacts    V AC	1,000	1,000	1,000
Ambient temperature range                      °C	-40...+70	-40...+70	-40...+70
Environmental protection	RT I	RT I	RT I
<b>Approvals:</b> (according to type)			

\* for 400 V applications, requirements for pollution degree 2 are met.

- 8 - 11 pin plug-in
- AC or DC coils
- Lockable test button with mechanical flag indicator
- Bifurcated contact option
- Sockets and accessories: see 90, 99 and 86 series

60

### 60.13 - 0200

### 60.62

### 60.63



- 3 bifurcated contacts
- 11 pin
- Plug-In for use with 90 series sockets

- 2 pole
- Faston 187 (4.8x0.8)mm with flange mount

- 3 pole
- Faston 187 (4.8x0.8)mm with flange mount

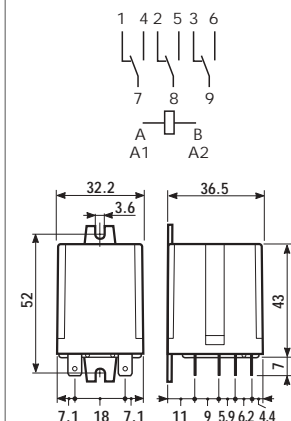
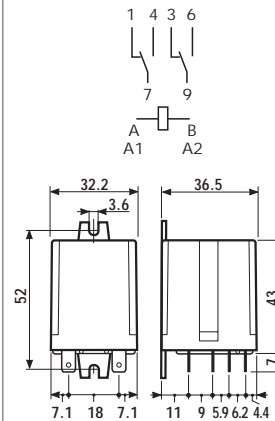
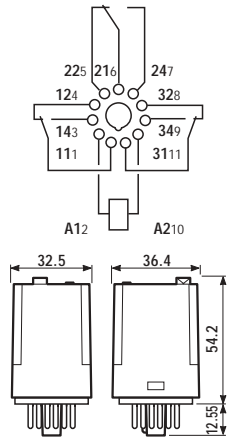

\* for 400 V applications, requirements for pollution degree 2 are met.

Contact specifications				
Contact configuration		3 CO	2 CO	3 CO
Rated current/Maximum peak current	A	6/10	10/20	10/20
Rated voltage/Maximum switching voltage	V AC	250/400*	250/400*	250/400*
Rated load in AC1	VA	1,500	2,500	2,500
Rated load in AC15 (230 VAC)	VA	250	500	500
Single phase motor rating (230 VAC)	kW	0.185	0.37	0.37
Breaking capacity in DC1: 30/110/220V	A	6/0.3/0.12	10/0.4/0.15	10/0.4/0.15
Minimum switching load	mW (V/mA)	50 (5/5)	500 (10/5)	500 (10/5)
Standard contact material		AgNi bifurcated contacts	AgNi	AgNi
Coil specifications				
Nominal voltage (U <sub>N</sub> )	V AC (50/60 Hz)	6 · 12 · 24 · 48 · 60 · 110 · 120 · 230 · 240		
	V DC	6 · 12 · 24 · 48 · 60 · 110		
Rated power AC/DC	VA (50 Hz)/W	2.2/1.3	2.2/1.3	2.2/1.3
Operating range	AC (50 Hz)	(0.8...1.1)U <sub>N</sub>	(0.8...1.1)U <sub>N</sub>	(0.8...1.1)U <sub>N</sub>
	DC	(0.8...1.1)U <sub>N</sub>	(0.8...1.1)U <sub>N</sub>	(0.8...1.1)U <sub>N</sub>
Holding voltage	AC/DC	0.8 U <sub>N</sub> /0.5 U <sub>N</sub>	0.8 U <sub>N</sub> /0.5 U <sub>N</sub>	0.8 U <sub>N</sub> /0.5 U <sub>N</sub>
Must drop-out voltage	AC/DC	0.2 U <sub>N</sub> /0.1 U <sub>N</sub>	0.2 U <sub>N</sub> /0.1 U <sub>N</sub>	0.2 U <sub>N</sub> /0.1 U <sub>N</sub>
Technical data				
Mechanical life AC/DC	cycles	20 · 10 <sup>6</sup> /50 · 10 <sup>6</sup>	20 · 10 <sup>6</sup> /50 · 10 <sup>6</sup>	20 · 10 <sup>6</sup> /50 · 10 <sup>6</sup>
Electrical life at rated load AC1	cycles	250 · 10 <sup>3</sup>	200 · 10 <sup>3</sup>	200 · 10 <sup>3</sup>
Operate/release time (bounce included)	ms	15/15	15/15	15/15
Insulation according to EN 61810-5		3.6 kV/3	3.6 kV/3	3.6 kV/3
Insulation between coil and contacts (1.2/50µs)	kV	3.6	3.6	3.6
Dielectric strength between open contacts	V AC	1,000	1,000	1,000
Ambient temperature range	°C	-40...+70	-40...+70	-40...+70
Environmental protection		RT I	RT I	RT I

**Approvals:** (according to type)



## ORDERING INFORMATION

Example: a 60 series plug-in relay, 3 CO (3PDT) with coil rated 12 V DC, test button and mechanical indicator.

	<b>6</b>	<b>0</b>	<b>.</b>	<b>1</b>	<b>.</b>	<b>3</b>	<b>.</b>	<b>9</b>	<b>.</b>	<b>0</b>	<b>1</b>	<b>2</b>	<b>.</b>	<b>0</b>	<b>A</b>	<b>B</b>	<b>C</b>	<b>D</b>	<b>0</b>
--	----------	----------	----------	----------	----------	----------	----------	----------	----------	----------	----------	----------	----------	----------	----------	----------	----------	----------	----------

**Series** —————

**Type** —————  
 1 = 8/11 pin plug-in  
 6 = Faston 187 (mm 4.8x0.8) with flange mount

**No. of poles** —————  
 2 = 2 pole  
 3 = 3 pole

**Coil version** —————  
 4 = Current sensing  
 8 = AC (50/60 Hz)  
 9 = DC

**Coil voltage** —————  
 see coil specifications

**A: Contact material**  
 0 = Standard  
 5 = AgNi + 5µm Au

**B: Contact circuit** —————  
 0 = CO  
 2 = Bifurcated contacts  
 60.12/13 · 6A only

**D: Special versions**  
 0 = Standard

**C: Options**  
 0 = None  
 1 = Test button  
 2 = Mechanical indicator  
 3 = LED (AC)  
 4 = Lockable test button + mechanical indicator  
 5 = Lockable test button + LED (AC)  
 54 = Lockable test button + LED (AC) + mechanical indicator  
 6 = LED + diode (positive to pin 2, DC)  
 7 = Lockable test button + LED + diode (positive to pin 2)  
 74 = Lockable test button + LED + diode (positive to pin 2) + mechanical indicator

**Only combinations in the same row are possible**

Preferred versions

	coil version	A	B	C	D
60.12/13	AC/DC	0	0	4	0
60.62/63	AC/DC	0	0	0	0

All versions

	coil version	A	B	C	D
60.12/13	AC	0	0	0 - 1 - 2 - 3 - 4 - 5	0
	AC	0	0	54	/
	AC	5	0 - 2	0 - 1 - 2 - 3 - 4 - 5	0
	AC	5	0 - 2	54	/
	DC	0	0	0 - 1 - 2 - 4 - 6 - 7	0
	DC	0	0	74	/
	DC	5	0 - 2	0 - 1 - 2 - 4 - 6 - 7	0
	DC	5	0 - 2	74	/
	current sensing	0	0	4	0
60.62/63	AC/DC	0 - 5	0	0	0

## POSSIBLE OPTIONS

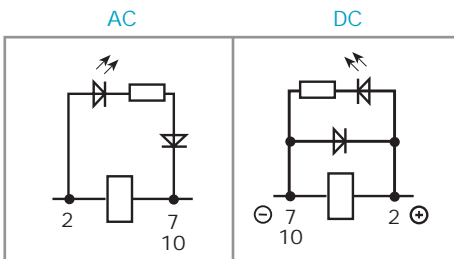

Option = 0030  
 0050  
 0054

Option = 0060  
 0070  
 0074

## ACCESSORIES

**060.72:** Sheet of marker tags see page 60.



### LOCKABLE TEST BUTTON AND MECHANICAL FLAG INDICATOR (0040)

The dual-purpose Finder test button can be used in two ways:

Case 1) The plastic pip (located directly above the test button) remains intact. In this case, when the test button is pushed, the contacts operate. When the test button is released the contacts return to their former state.

Case 2) The plastic pip is broken-off (using an appropriate cutting tool). In this case, (in addition to the above function), when the test button is pushed and rotated, the contacts are latched in the operating state, and remain so until the test button is rotated back to its former position.

In both cases ensure that the test button actuation is swift and decisive.

## TECHNICAL DATA

### INSULATION

INSULATION according to EN 61810-5	insulation rated voltage	V	250
	rated impulse withstand voltage	kV	3.6
	pollution degree		3
	overvoltage category		III

### IMMUNITY

CONDUCTED DISTURBANCE IMMUNITY	BURST (according to EN 61000-4-4) level 4 (4kV)
	SURGE (according to EN 61000-4-5) level 4 (4kV)

### OTHER DATA

VIBRATION RESISTANCE (10...55Hz): NO/NC	g/g	5/3
POWER LOST TO THE ENVIRONMENT		<b>2 CO</b>
without contact current	W	1.3
with rated current	W	2.7
		<b>3 CO</b>
		1.3
		3.4

60

## CONTACT SPECIFICATIONS

### F 60

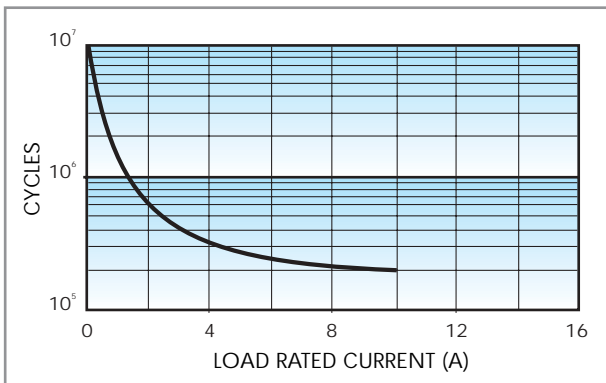

Electrical life vs AC1 load.

### H 60

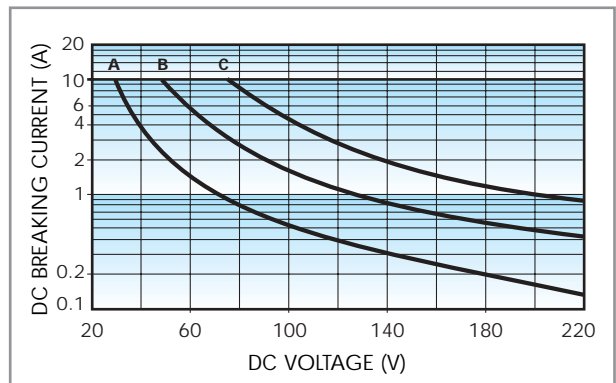

Breaking capacity for DC1 load.

- A** = Load applied to 1 contact
- B** = Load applied to 2 contacts in series
- C** = Load applied to 3 contacts in series

- When switching a resistive load (DC1) having voltage and current values under the curve the expected electrical life is  $\geq 100 \cdot 10^3$  cycles.
  - In case of DC13 loads the connection of a diode in parallel with the load will permit the same electrical life as for a DC1 load.
- Note:** the release time of load will be increase.

## COIL SPECIFICATIONS

### AC VERSION DATA

Nominal voltage $U_N$ V	Coil code	Operating range		Resistance R $\Omega$	Rated coil consumption I at $U_N$ (50Hz) mA
		$U_{min}$ V	$U_{max}$ V		
6	8.006	4.8	6.6	4.6	367
12	8.012	9.6	13.2	19	183
24	8.024	19.2	26.4	74	90
48	8.048	38.4	52.8	290	47
60	8.060	48	66	450	37
110	8.110	88	121	1,600	20
120	8.120	96	132	1,940	18.6
230	8.230	184	253	7,250	10.5
240	8.240	192	264	8,500	9.2

### DC VERSION DATA

Nominal voltage $U_N$ V	Coil code	Operating range		Resistance R $\Omega$	Rated coil consumption I at $U_N$ mA
		$U_{min}$ V	$U_{max}$ V		
6	9.006	4.8	6.6	28	214
12	9.012	9.6	13.2	110	109
24	9.024	19.2	26.4	445	53.9
48	9.048	38.4	52.8	1,770	27.1
60	9.060	48	66	2,760	21.7
110	9.110	88	121	9,420	11.7

### R 60 AC

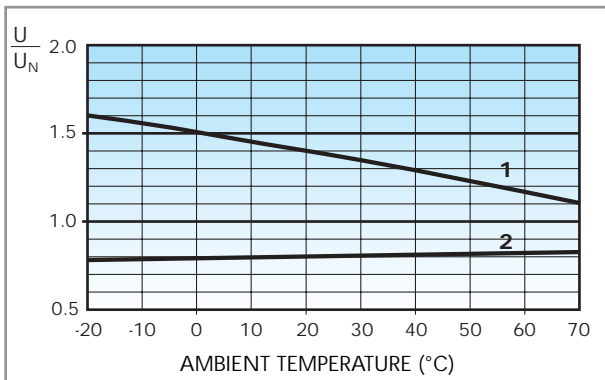

Operating range (AC version) vs ambient temperature.

- 1 - Max coil voltage permitted.
- 2 - Min pick-up voltage with coil at ambient temperature.

### R 60 DC

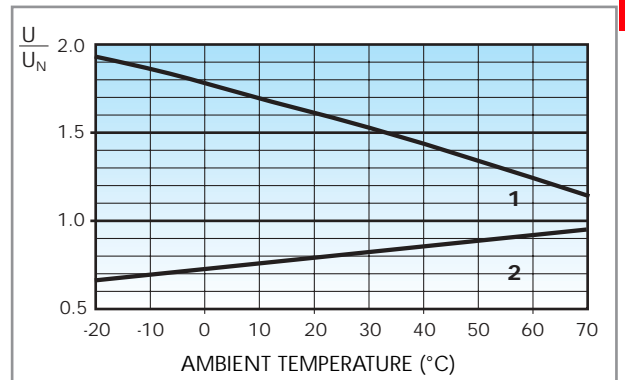

Operating range (DC version) vs ambient temperature.

- 1 - Max coil voltage permitted.
- 2 - Min pick-up voltage with coil at ambient temperature.

## CURRENT SENSING VERSION

### Wiring Diagram

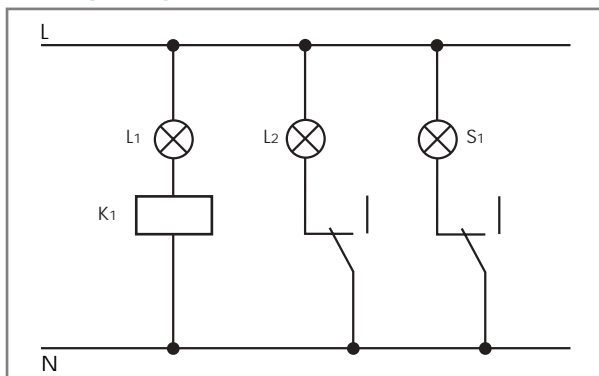

Typical application with current sensing relays.

An open circuit filament of lamp L1 is detected by the current sensing relay coil (K1) which causes the back-up safety lamp L2 to be energised, and indication of failure at the control panel via lamp S1.

Example: navigation light.

- L1 = Light
- L2 = Safety light
- S1 = Control light
- K1 = Relay

### 60 Series - CURRENT SENSING AC

Coil code	$I_{min}$ (A)	$I_N$ (A)	$I_{max}$ (A)	R ( $\Omega$ )
4251	2.1	2.5	3.0	0.05
4181	1.5	1.8	2.2	0.10
4161	1.4	1.6	1.9	0.12
4121	1.0	1.2	1.4	0.22
4101	0.85	1.0	1.2	0.32
4051	0.42	0.5	0.6	1.28
4041	0.34	0.4	0.5	2.00
4031	0.25	0.3	0.4	3.57
4021	0.17	0.2	0.25	8.0
4011	0.085	0.1	0.15	32.1

### 60 Series - CURRENT SENSING DC

Coil code	$I_{min}$ (A)	$I_N$ (A)	$I_{max}$ (A)	R ( $\Omega$ )
4202	1.7	2.0	2.4	0.15
4182	1.5	1.8	2.2	0.19
4162	1.4	1.6	1.9	0.24
4142	1.2	1.4	1.7	0.31
4122	1.0	1.2	1.4	0.42
4102	0.85	1.0	1.2	0.61
4092	0.8	0.9	1.1	0.75
4062	0.5	0.6	0.7	1.70
4032	0.25	0.3	0.4	6.70
4012	0.085	0.1	0.15	61

Other types of current sensing relays are available on request.



Approval:  
(accordin

51x9 / 5x5.2







Relay type	60.12		60.13	
Colour	BLUE	BLACK	BLUE	BLACK
<b>Clamp terminal socket:</b> panel or 35 mm rail (EN 50022) mount	90.72	90.72.0	90.73	90.73.0
Retaining clip	090.33			
Timer module	86.60			

Approvals  
(according to type):



- Double ground terminal (A2).
- RATED VALUES: 10 A - 250 V
- DIELECTRIC STRENGTH:  $\geq 2$  kV AC
- PROTECTION CATEGORY: IP 20
- AMBIENT TEMPERATURE:  $(-40...+70)^{\circ}\text{C}$
- SCREW TORQUE: 0.8 Nm
- WIRE STRIP LENGTH: 7 mm
- MAX WIRE SIZE:

	solid wire	stranded wire
mm <sup>2</sup>	1x6 / 2x4	1x6 / 2x4
AWG	1x10 / 2x12	1x10 / 2x12

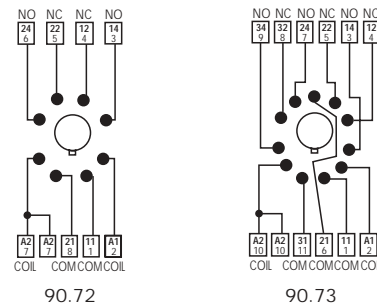
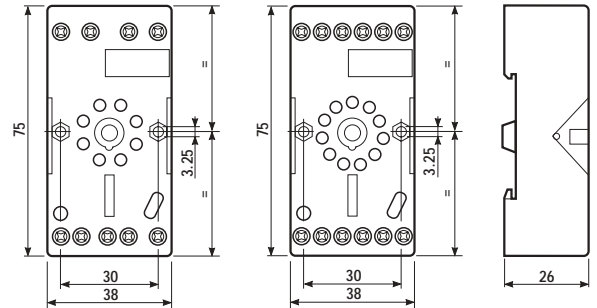

60



Relay type	60.12		60.13	
Colour	BLUE	BLACK	BLUE	BLACK
<b>Clamp terminal socket:</b> panel or 35 mm rail (EN 50022) mount	90.22	90.22.0	90.23	90.23.0
retaining clip 090.33 supplied with socket packaging code SMA				
Retaining clip	090.33			

Approvals  
(according to type):



- RATED VALUES: 10 A - 250 V
- DIELECTRIC STRENGTH:  $\geq 2$  kV AC
- PROTECTION CATEGORY: IP 20
- AMBIENT TEMPERATURE:  $(-40...+70)^{\circ}\text{C}$
- SCREW TORQUE: 0.5 Nm
- WIRE STRIP LENGTH: 7 mm
- MAX WIRE SIZE:

	solid wire	stranded wire
mm <sup>2</sup>	1x6 / 2x2.5	1x6 / 2x2.5
AWG	1x10 / 2x14	1x10 / 2x14

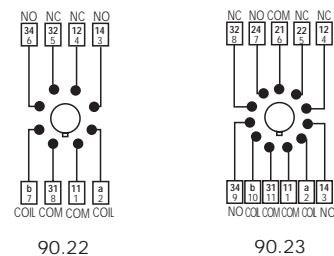
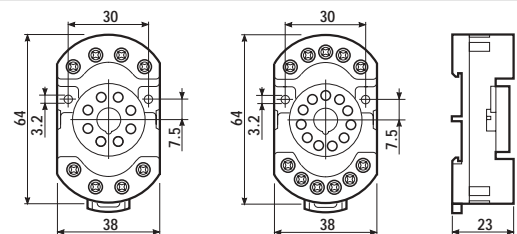



90.26

Approvals  
(according to type):

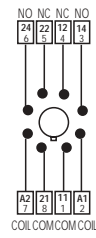
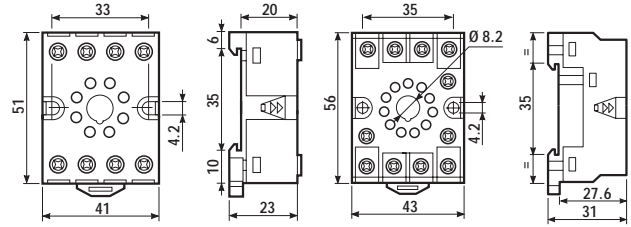

90.26

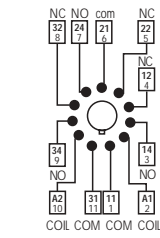

90.27



90.12

Approvals  
(according to type):

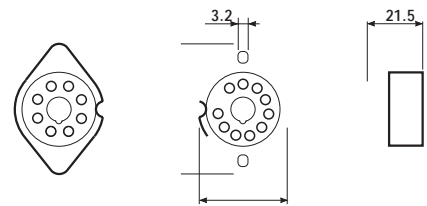

## PACKAGING CODES

How to code and identify retaining clip and packaging options for sockets.

Code options according to the last three letters:

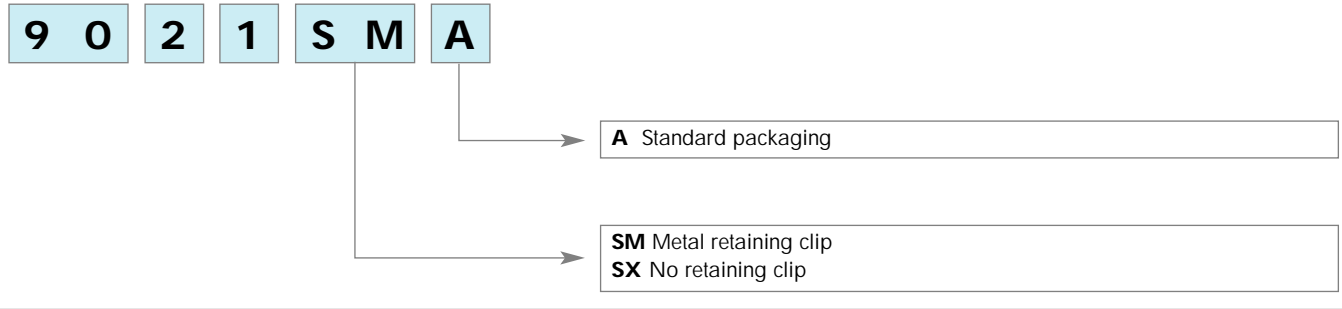

- Plug-in or P.C.B. versions
- AC or DC coils
- 3 mm gap between open contacts on NO option
- 8 mm, 6 kV (1.2/50 μs) between coil and contacts (internal distance)

62.22

62.23

62.32

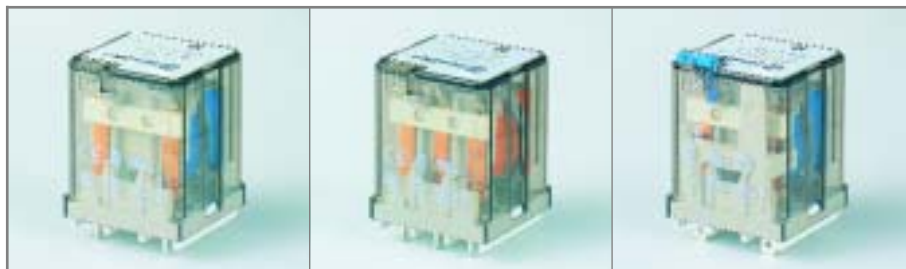

- 2 pole  
- P.C.B. mounting

- 3 pole  
- P.C.B. mounting

- 2 pole  
- Faston 187 (4.8x0.5)mm  
- Plug-in use 92 Series socket

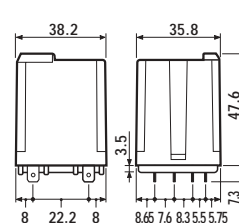
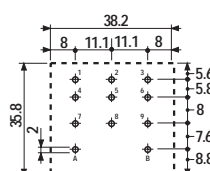
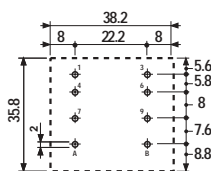
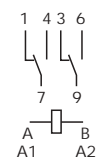
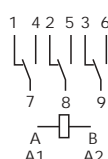
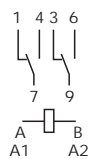

Copper side view

Copper side view

h = 49.1 mm

h = 49.1 mm

Contact specifications

Contact configuration		2 CO	3 CO	2 CO
Rated current/Maximum peak current	A	16/30	16/30	16/30
Rated voltage/Maximum switching voltage	V AC	250/400	250/400	250/400
Rated load in AC1	VA	4,000	4,000	4,000
Rated load in AC15 (230 VAC)	VA	750	750	750
Single phase motor rating (230 VAC)	kW	0.8	0.8	0.8
Breaking capacity in DC1: 30/110/220V	A	16/0.6/0.4	16/0.6/0.4	16/0.6/0.4
Minimum switching load	mW (V/mA)	1,000 (10/10)	1,000 (10/10)	1,000 (10/10)
Standard contact material		AgCdO	AgCdO	AgCdO

Coil specifications

Nominal voltage (U <sub>N</sub> )	V AC (50/60 Hz)	6 · 12 · 24 · 48 · 60 · 110 · 120 · 230 · 240		
	V DC	6 · 12 · 24 · 48 · 60 · 110		
Rated power AC/DC	VA (50 Hz)/W	2.2/1.3	2.2/1.3	2.2/1.3
Operating range	AC (50 Hz)	(0.8...1.1)U <sub>N</sub>	(0.8...1.1)U <sub>N</sub>	(0.8...1.1)U <sub>N</sub>
	DC	(0.8...1.1)U <sub>N</sub>	(0.8...1.1)U <sub>N</sub>	(0.8...1.1)U <sub>N</sub>
Holding voltage	AC/DC	0.8 U <sub>N</sub> /0.6 U <sub>N</sub>	0.8 U <sub>N</sub> /0.6 U <sub>N</sub>	0.8 U <sub>N</sub> /0.6 U <sub>N</sub>
Must drop-out voltage	AC/DC	0.2 U <sub>N</sub> /0.1 U <sub>N</sub>	0.2 U <sub>N</sub> /0.1 U <sub>N</sub>	0.2 U <sub>N</sub> /0.1 U <sub>N</sub>

Technical data

Mechanical life AC/DC	cycles	10 · 10 <sup>6</sup> /30 · 10 <sup>6</sup>	10 · 10 <sup>6</sup> /30 · 10 <sup>6</sup>	10 · 10 <sup>6</sup> /30 · 10 <sup>6</sup>
Electrical life at rated load AC1	cycles	100 · 10 <sup>3</sup>	100 · 10 <sup>3</sup>	100 · 10 <sup>3</sup>
Operate/release time (bounce included)	ms	20/20	20/20	20/20
Insulation according to EN 61810-5		4kV/3	4kV/3	4kV/3
Insulation between coil and contacts (1.2/50μs)	kV	6	6	6
Dielectric strength between open contacts	V AC	1,500	1,500	1,500
Ambient temperature range	°C	-40...+70	-40...+70	-40...+70
Environmental protection		RT I	RT I	RT I

Approvals: (according to type)



- Plug-in or P.C.B. versions
- AC or DC coils
- 3 mm gap between open contacts on NO option
- 8 mm, 6 kV (1.2/50 μs) between coil and contacts (internal distance)

	62.33	62.82	62.83
	- 3 pole - Faston 187 (4.8x0.5)mm - Plug-in use 92 Series socket	- 2 pole - Faston 250 (6.3x0.8)mm with flange mount	- 3 pole - Faston 250 (6.3x0.8)mm with flange mount
<b>Contact specifications</b>			
Contact configuration	3 CO	2 CO	3 CO
Rated current/Maximum peak current A	16/30	16/30	16/30
Rated voltage/Maximum switching voltage V AC	250/400	250/400	250/400
Rated load in AC1 VA	4,000	4,000	4,000
Rated load in AC15 (230 VAC) VA	750	750	750
Single phase motor rating (230 VAC) kW	0.8	0.8	0.8
Breaking capacity in DC1: 30/110/220V A	16/0.6/0.4	16/0.6/0.4	16/0.6/0.4
Minimum switching load mW (V/mA)	1,000 (10/10)	1,000 (10/10)	1,000 (10/10)
Standard contact material	AgCdO	AgCdO	AgCdO
<b>Coil specifications</b>			
Nominal voltage (U <sub>N</sub> ) V AC (50/60 Hz)	6 - 12 - 24 - 48 - 60 - 110 - 120 - 230 - 240		
V DC	6 - 12 - 24 - 48 - 60 - 110		
Rated power AC/DC VA (50 Hz)/W	2.2/1.3	2.2/1.3	2.2/1.3
Operating range AC (50 Hz)	(0.8...1.1)U <sub>N</sub>	(0.8...1.1)U <sub>N</sub>	(0.8...1.1)U <sub>N</sub>
DC	(0.8...1.1)U <sub>N</sub>	(0.8...1.1)U <sub>N</sub>	(0.8...1.1)U <sub>N</sub>
Holding voltage AC/DC	0.8 U <sub>N</sub> /0.6 U <sub>N</sub>	0.8 U <sub>N</sub> /0.6 U <sub>N</sub>	0.8 U <sub>N</sub> /0.6 U <sub>N</sub>
Must drop-out voltage AC/DC	0.2 U <sub>N</sub> /0.1 U <sub>N</sub>	0.2 U <sub>N</sub> /0.1 U <sub>N</sub>	0.2 U <sub>N</sub> /0.1 U <sub>N</sub>
<b>Technical data</b>			
Mechanical life AC/DC cycles	10 · 10 <sup>6</sup> /30 · 10 <sup>6</sup>	10 · 10 <sup>6</sup> /30 · 10 <sup>6</sup>	10 · 10 <sup>6</sup> /30 · 10 <sup>6</sup>
Electrical life at rated load AC1 cycles	100 · 10 <sup>3</sup>	100 · 10 <sup>3</sup>	100 · 10 <sup>3</sup>
Operate/release time (bounce included) ms	20/20	20/20	20/20
Insulation according to EN 61810-5	4 kV/3	4 kV/3	4 kV/3
Insulation between coil and contacts (1.2/50μs) kV	6	6	6
Dielectric strength between open contacts V AC	1,500	1,500	1,500
Ambient temperature range °C	-40...+70	-40...+70	-40...+70
Environmental protection	RT I	RT I	RT I
<b>Approvals:</b> (according to type)			

- Plug-in or P.C.B. versions
- AC or DC coils
- 3 mm gap between open contacts on NO option
- 8 mm, 6 kV (1.2/50 μs) between coil and contacts (internal distance)

### 62.22 - 0300

### 62.23 - 0300

### 62.32 - 0300



- 2 NO (3mm contact gap)  
- P.C.B. mounting

- 3 NO (3mm contact gap)  
- P.C.B. mounting

- 2 NO (3mm contact gap)  
- Faston 187 (4.8x0.5)mm  
- Plug-in use 92 Series socket

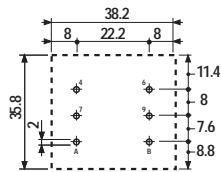
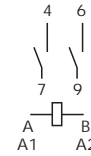
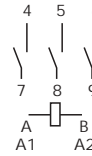
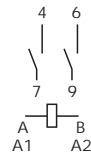

Copper side view

h = 51.1 mm

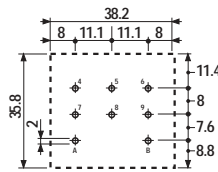

Copper side view

h = 51.1 mm

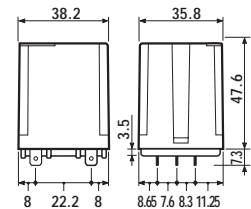

\* Distance between contacts >3mm (EN 60335-1)

Contact specifications												
Contact configuration			2 NO 3 mm*	3 NO 3 mm*	2 NO 3 mm*							
Rated current/Maximum peak current	A		16/30	16/30	16/30							
Rated voltage/Maximum switching voltage	V AC		250/400	250/400	250/400							
Rated load in AC1	VA		4,000	4,000	4,000							
Rated load in AC15 (230 VAC)	VA		750	750	750							
Single phase motor rating (230 VAC)	kW		0.8	0.8	0.8							
Breaking capacity in DC1: 30/110/220V	A		16/1.1/0.7	16/1.1/0.7	16/1.1/0.7							
Minimum switching load	mW (V/mA)		1,000 (10/10)	1,000 (10/10)	1,000 (10/10)							
Standard contact material			AgCdO	AgCdO	AgCdO							
Coil specifications												
Nominal voltage (U <sub>N</sub> )	V AC (50/60 Hz)		6 - 12 - 24 - 48 - 60 - 110 - 120 - 230 - 240									
	V DC		6 - 12 - 24 - 48 - 60 - 110									
Rated power AC/DC	VA (50 Hz)/W		3/3	3/3	3/3							
Operating range	AC (50 Hz)		(0.85...1.1)U <sub>N</sub>	(0.85...1.1)U <sub>N</sub>	(0.85...1.1)U <sub>N</sub>							
	DC		(0.85...1.1)U <sub>N</sub>	(0.85...1.1)U <sub>N</sub>	(0.85...1.1)U <sub>N</sub>							
Holding voltage	AC/DC		0.8 U <sub>N</sub> /0.6 U <sub>N</sub>	0.8 U <sub>N</sub> /0.6 U <sub>N</sub>	0.8 U <sub>N</sub> /0.6 U <sub>N</sub>							
Must drop-out voltage	AC/DC		0.2 U <sub>N</sub> /0.1 U <sub>N</sub>	0.2 U <sub>N</sub> /0.1 U <sub>N</sub>	0.2 U <sub>N</sub> /0.1 U <sub>N</sub>							
Technical data												
Mechanical life AC/DC	cycles		10 · 10 <sup>6</sup> /30 · 10 <sup>6</sup>	10 · 10 <sup>6</sup> /30 · 10 <sup>6</sup>	10 · 10 <sup>6</sup> /30 · 10 <sup>6</sup>							
Electrical life at rated load AC1	cycles		100 · 10 <sup>3</sup>	100 · 10 <sup>3</sup>	100 · 10 <sup>3</sup>							
Operate/release time (bounce included)	ms		30/—	30/—	30/—							
Insulation according to EN 61810-5			4kV/3	4kV/3	4kV/3							
Insulation between coil and contacts (1.2/50μs)		kV	6	6	6							
Dielectric strength between open contacts		V AC	2,500	2,500	2,500							
Ambient temperature range		°C	-40...+50	-40...+50	-40...+50							
Environmental protection			RT I	RT I	RT I							
Approvals: (according to type)			CE	ABS	SGS	GOST	UL	RINA	S	CS	UL	VDE

- Plug-in or P.C.B. versions
- AC or DC coils
- 3 mm gap between open contacts on NO option
- 8 mm, 6 kV (1.2/50 μs) between coil and contacts (internal distance)

### 62.33 - 0300

### 62.82 - 0300

### 62.83 - 0300



- 3 NO (3mm contact gap)
- Faston 187 (4.8x0.5)mm
- Plug-in use 92 Series socket

- 2 NO (3mm contact gap)
- Faston 250 (6.3x0.8)mm with flange mount

- 3 NO (3mm contact gap)
- Faston 250 (6.3x0.8)mm with flange mount

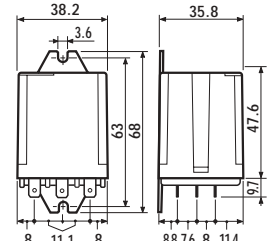
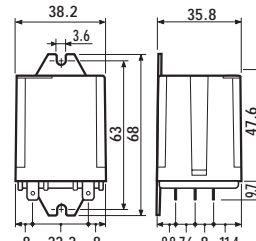
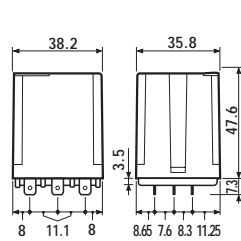
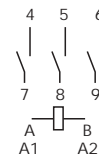
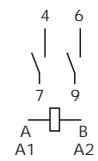
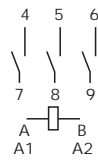

\* Distance between contacts >3mm (EN 60335-1)

Contact specifications		62.33 - 0300	62.82 - 0300	62.83 - 0300
Contact configuration		3 NO 3 mm*	2 NO 3 mm*	3 NO 3 mm*
Rated current/Maximum peak current	A	16/30	16/30	16/30
Rated voltage/Maximum switching voltage	V AC	250/400	250/400	250/400
Rated load in AC1	VA	4,000	4,000	4,000
Rated load in AC15 (230 VAC)	VA	750	750	750
Single phase motor rating (230 VAC)	kW	0.8	0.8	0.8
Breaking capacity in DC1: 30/110/220V	A	16/1.1/0.7	16/1.1/0.7	16/1.1/0.7
Minimum switching load	mW (V/mA)	1,000 (10/10)	1,000 (10/10)	1,000 (10/10)
Standard contact material		AgCdO	AgCdO	AgCdO
Coil specifications		6 - 12 - 24 - 48 - 60 - 110 - 120 - 230 - 240		
Nominal voltage (U <sub>N</sub> )	V AC (50/60 Hz)			
	V DC	6 - 12 - 24 - 48 - 60 - 110		
Rated power AC/DC	VA (50 Hz)/W	3/3	3/3	3/3
Operating range	AC (50 Hz)	(0.85...1.1)U <sub>N</sub>	(0.85...1.1)U <sub>N</sub>	(0.85...1.1)U <sub>N</sub>
	DC	(0.85...1.1)U <sub>N</sub>	(0.85...1.1)U <sub>N</sub>	(0.85...1.1)U <sub>N</sub>
Holding voltage	AC/DC	0.8 U <sub>N</sub> /0.6 U <sub>N</sub>	0.8 U <sub>N</sub> /0.6 U <sub>N</sub>	0.8 U <sub>N</sub> /0.6 U <sub>N</sub>
Must drop-out voltage	AC/DC	0.2 U <sub>N</sub> /0.1 U <sub>N</sub>	0.2 U <sub>N</sub> /0.1 U <sub>N</sub>	0.2 U <sub>N</sub> /0.1 U <sub>N</sub>
Technical data				
Mechanical life AC/DC	cycles	10 · 10 <sup>6</sup> /30 · 10 <sup>6</sup>	10 · 10 <sup>6</sup> /30 · 10 <sup>6</sup>	10 · 10 <sup>6</sup> /30 · 10 <sup>6</sup>
Electrical life at rated load AC1	cycles	100 · 10 <sup>3</sup>	100 · 10 <sup>3</sup>	100 · 10 <sup>3</sup>
Operate/release time (bounce included)	ms	30/—	30/—	30/—
Insulation according to EN 61810-5		4 kV/3	4 kV/3	4 kV/3
Insulation between coil and contacts (1.2/50μs)	kV	6	6	6
Dielectric strength between open contacts	V AC	2,500	2,500	2,500
Ambient temperature range	°C	-40...+50	-40...+50	-40...+50
Environmental protection		RT I	RT I	RT I

## ORDERING INFORMATION

Example: a 62 series power relay + FASTON 250 rear flange mount (6.3 x 0.8 mm) with 2 NO contacts, coil rated at 12 V DC.

<p><b>Series</b> ———</p> <p><b>Type</b> ———</p> <p>2 = P.C.B. 3 = Plug-in 8 = Faston 250 (6.3x0.8 mm) with rear flange mount</p> <p><b>No. of poles</b> ———</p> <p>2 = 2 pole 3 = 3 pole</p> <p><b>Coil version</b> ———</p> <p>8 = AC (50/60 Hz) 9 = DC</p> <p><b>Coil voltage</b> ———</p> <p>see coil specifications</p>	<p><b>A: Contact material</b> 0 = Standard AgCdO 4 = AgSnO<sub>2</sub></p> <p><b>B: Contact circuit</b> ———</p> <p>0 = CO 3 = NO (≥ 3 mm contact gap) 5 = CO version with coil to contacts SELV insulation 6 = NO (≥ 3 mm contact gap) version with coil to contacts SELV insulation</p>	<p><b>D: Special versions</b> 0 = Standard 5 = Top flange mount 6 = Rear flange mount 7 = Top 35 mm rail mount 8 = Rear 35 mm rail mount 9 = Type 62.82/83 without rear flange mount</p> <p><b>C: Options</b> 0 = None 2 = Mechanical indicator 3 = LED (AC) 4 = Lockable test button + mechanical indicator 5 = Lockable test button + LED (AC) 54 = Lockable test button + LED (AC) + mechanical indicator 6 = LED + diode (DC polarity positive to pin A/A1) 7 = Lockable test button + LED + diode (DC polarity positive to pin A/A1) 74 = Lockable test button + LED + diode (DC polarity positive to pin A/A1) + mechanical indicator</p>
---	--	---

62

### Only combinations in the same row are possible

Preferred versions

	coil version	A	B	C	D
62.22/23	AC-DC	0	0	0	0
62.32/33	AC-DC	0	0	4	0
62.82/83	AC-DC	0	0	0	0

All versions

	coil version	A	B	C	D
62.22/23	AC-DC	0 - 4	0 - 3 - 5 - 6	0	0
62.32/33	AC-DC	0 - 4	0 - 3 - 5 - 6	0	0 - 5 - 6 - 7 - 8
	AC-DC	0 - 4	5	2 - 4	0 - 6 - 8
	AC	0 - 4	0	2 - 3 - 4 - 5	0 - 6 - 8
	AC	0 - 4	3	3	0 - 6 - 8
	AC	0 - 4	0	54	/
	DC	0 - 4	0	4 - 6 - 7	0 - 6 - 8
	DC	0 - 4	3	6	0 - 6 - 8
	DC	0 - 4	0	74	/
62.82/83	AC-DC	0 - 4	0 - 3 - 5 - 6	0	0 - 5 - 7 - 8 - 9
	AC-DC	0 - 4	5	2 - 4	0 - 8
	AC	0 - 4	0	2 - 3 - 4 - 5	0 - 8
	AC	0 - 4	3	3	0 - 8
	DC	0 - 4	0	4 - 6 - 7	0 - 8
	DC	0 - 4	3	6	0 - 8

## POSSIBLE OPTIONS

AC

DC

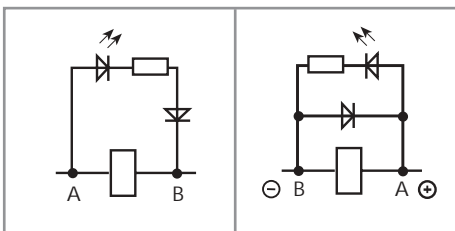

Option = 0030  
0050

Option = 0060  
0070



Option = 0005  
TOP MOUNT FLANGE

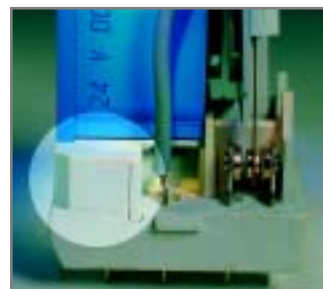

Option = 0500 and 0600  
COIL TO CONTACTS PHYSICAL SEPARATOR FOR SELV APPLICATIONS

### ACCESSORIES

**060.72:** Sheet of marker tags see page 70.



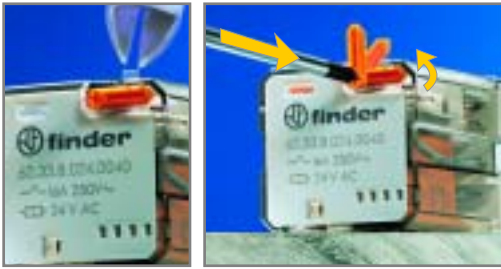

### LOCKABLE TEST BUTTON AND MECHANICAL FLAG INDICATOR (0040)

The dual-purpose Finder test button can be used in two ways:

**Case 1)** The plastic pip (located directly above the test button) remains intact. In this case, when the test button is pushed, the contacts operate. When the test button is released the contacts return to their former state.

**Case 2)** The plastic pip is broken-off (using an appropriate cutting tool). In this case, (in addition to the above function), when the test button is pushed and rotated, the contacts are latched in the operating state, and remain so until the test button is rotated back to its former position. In both cases ensure that the test button actuation is swift and decisive.

## TECHNICAL DATA

### INSULATION

INSULATION according to EN 61810-5	insulation rated voltage	V	400
	rated impulse withstand voltage	kV	4
	pollution degree		3
	overvoltage category		III

### IMMUNITY

CONDUCTED DISTURBANCE IMMUNITY	BURST (according to EN 61000-4-4) level 4 (4 kV)
	SURGE (according to EN 61000-4-5) level 4 (4kV)

### OTHER DATA

VIBRATION RESISTANCE (10...55Hz): NO/NC	g/g	5/3				
POWER LOST TO THE ENVIRONMENT		<b>2 CO</b>	<b>3 CO</b>	<b>2 NO</b>	<b>3 NO</b>	
	without contact current	W	1.3	1.3	3	3
	with rated current	W	3.3	4.3	5	6
RECOMMENDED DISTANCE between RELAYS mounted on P.C.B.s	mm	≥5				

62

## CONTACT SPECIFICATIONS

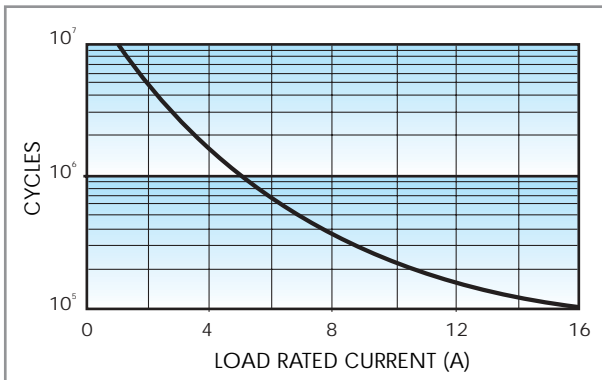

F 62

Electrical life vs AC1 load.

### H 62 (CO)

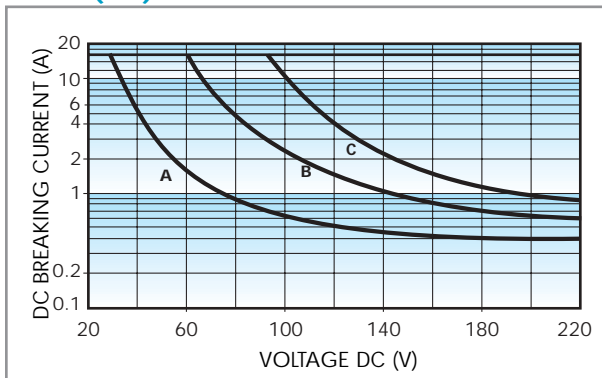

Breaking capacity for DC1 load.

- A** = Load applied to 1 contact.
- B** = Load applied to 2 contacts in series.
- C** = Load applied to 3 contacts in series.

- When switching a resistive load (DC1) having voltage and current values under the curve the expected electrical life is  $\geq 100 \cdot 10^3$  cycles.
  - In case of DC13 loads the connection of a diode in parallel with the load will permit the same electrical life as for a DC1 load.
- Note:** the release time of load will be increase.

### H 62 (NO)

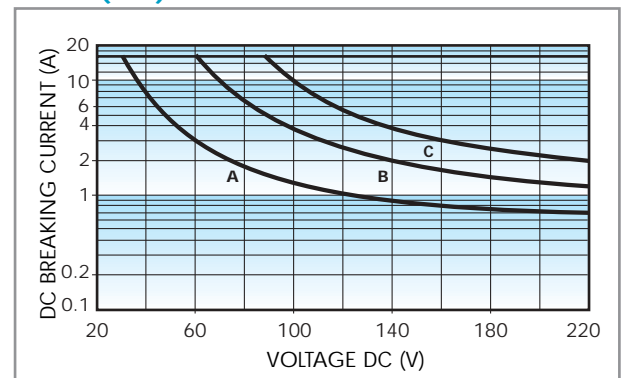

Breaking capacity for DC1 load.

- A** = Load applied to 1 contact.
- B** = Load applied to 2 contacts in series.
- C** = Load applied to 3 contacts in series.

- When switching a resistive load (DC1) having voltage and current values under the curve the expected electrical life is  $\geq 100 \cdot 10^3$  cycles.
  - In case of DC13 loads the connection of a diode in parallel with the load will permit the same electrical life as for a DC1 load.
- Note:** the release time of load will be increase.

## COIL SPECIFICATIONS

### AC VERSION DATA

Nominal voltage $U_N$ V	Coil code	Operating range		Resistance R $\Omega$	Rated coil consumption I at $U_N$ (50Hz) mA
		$U_{min}$ V	$U_{max}$ V		
6	8.006	4.8	6.6	4.6	367
12	8.012	9.6	13.2	19	183
24	8.024	19.2	26.4	74	90
48	8.048	38.4	52.8	290	47
60	8.060	48	66	450	37
110	8.110	88	121	1,600	20
120	8.120	96	132	1,940	18.6
230	8.230	184	253	7,250	10.5
240	8.240	192	264	8,500	9.2

### DC VERSION DATA

Nominal voltage $U_N$ V	Coil code	Operating range		Resistance R $\Omega$	Rated coil consumption I at $U_N$ mA
		$U_{min}$ V	$U_{max}$ V		
6	9.006	4.8	6.6	28	214
12	9.012	9.6	13.2	110	109
24	9.024	19.2	26.4	445	54
48	9.048	38.4	52.8	1,770	27
60	9.060	48	66	2,760	21.7
110	9.110	88	121	9,420	11.7

### AC (NO) VERSION DATA ( $\geq 3$ mm)

Nominal voltage $U_N$ V	Coil code	Operating range		Resistance R $\Omega$	Rated coil consumption I at $U_N$ (50Hz) mA
		$U_{min}$ V	$U_{max}$ V		
6	8.006	5.1	6.6	4	540
12	8.012	10.2	13.2	14	275
24	8.024	20.4	26.4	62	130
48	8.048	40.8	52.8	220	70
60	8.060	51	66	348	55
110	8.110	93.5	121	1,200	30
120	8.120	106	137	1,350	24
230	8.230	196	253	5,000	14
240	8.240	204	264	6,300	12.5

### DC (NO) VERSION DATA ( $\geq 3$ mm)

Nominal voltage $U_N$ V	Coil code	Operating range		Resistance R $\Omega$	Rated coil consumption I at $U_N$ mA
		$U_{min}$ V	$U_{max}$ V		
6	9.006	5.1	6.6	12	500
12	9.012	10.2	13.2	48	250
24	9.024	20.4	26.4	192	125
48	9.048	40.8	52.8	770	63
60	9.060	51	66	1,200	50
110	9.110	93.5	121	4,200	26

### R 62 AC

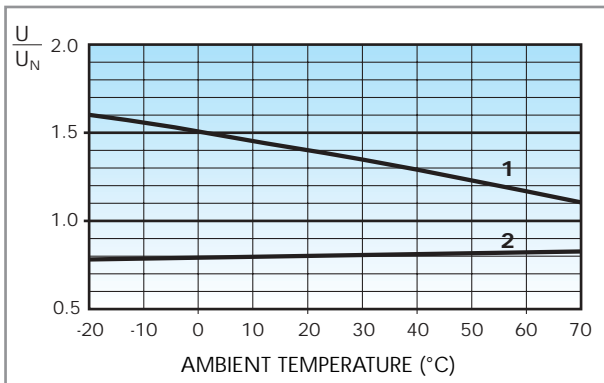

### R 62 DC

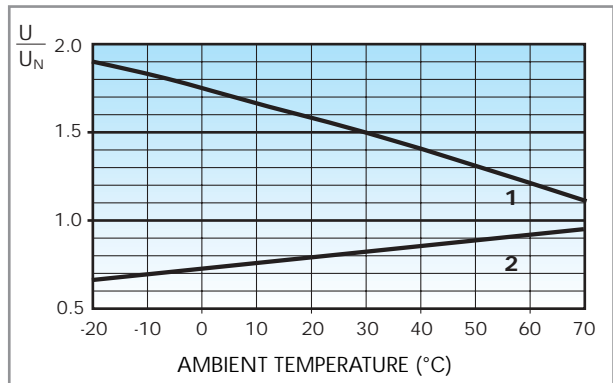

### R 62 AC (NO)

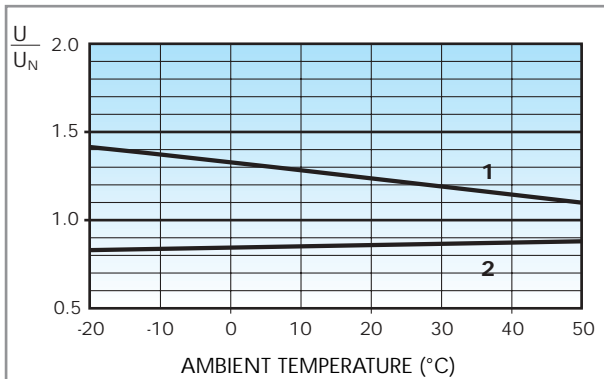

### R 62 DC (NO)

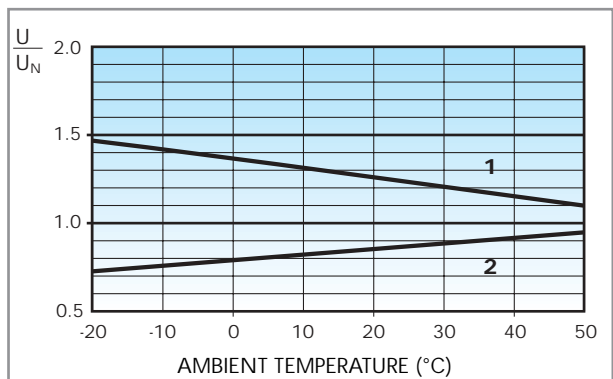

Operating range (AC type) vs ambient temperature.

- 1 - Max coil voltage permitted.
- 2 - Min pick-up voltage with coil at ambient temperature.

Operating range (DC type) vs ambient temperature.

- 1 - Max coil voltage permitted.
- 2 - Min pick-up voltage with coil at ambient temperature.

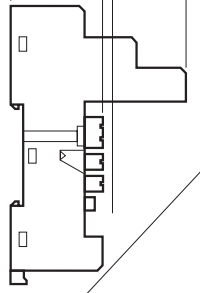
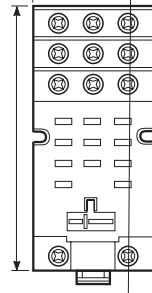



92.13

<b>Relay type</b>	<b>62.32</b>	
Colour	BLUE	BLACK
<b>P.C.B. socket</b>	92.13	92.13.0
retaining clip O92.54 supplied with socket packaging code SMA		
Retaining clip	O92.54	

Approvals  
(according to type):



- RATED VALUES: 32 A - 250 V (10 A max for each contact circuit)
- DIELECTRIC STRENGTH:  $\geq 2.5$  kV AC
- AMBIENT TEMPERATURE: (-40...+70) $^{\circ}$ C

- 62.3X plug on 92.13 is 63.3 mm high

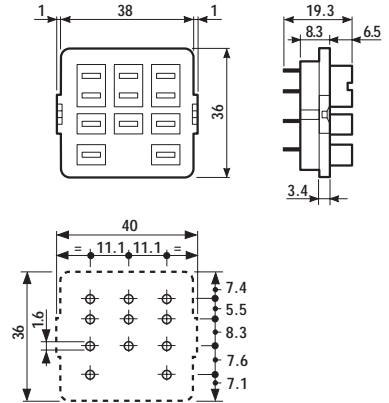

62



92.33

<b>Relay type</b>	<b>62.32</b>	<b>62.33</b>
Colour	BLUE	BLUE
<b>Panel mount solder socket:</b> mounted with M3 screw	92.33	92.33
retaining clip O92.54 supplied with socket packaging code SMA		
Retaining clip	O92.54	

Approvals  
(according to type):



- RATED VALUES: 32 A - 250 V (10 A max for each contact circuit)
- DIELECTRIC STRENGTH:  $\geq 2.5$  kV AC
- AMBIENT TEMPERATURE: (-40...+70) $^{\circ}$ C

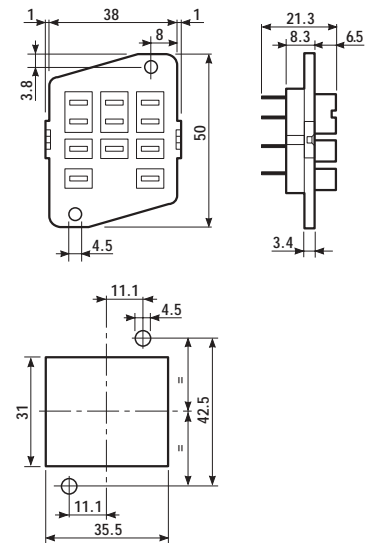

## ACCESSORIES



062.10

<b>Mounting adaptor</b> for types 62.3x and 62.8x (M4)	062.10
--	--------

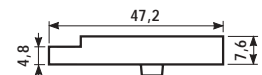

062.10

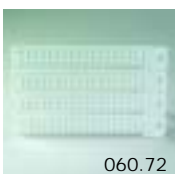
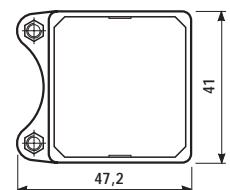

060.72

<b>Sheet of marker tags</b> for 62 series relays (72 tags)	060.72
--	--------

## PACKAGING CODES

How to code and identify retaining clip and packaging options for sockets.

Code options according to the last three letters:

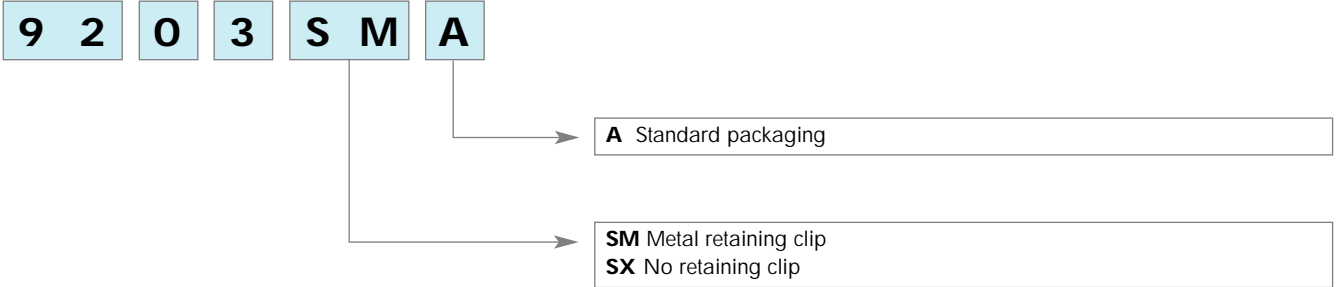

**65.31**
**65.61**

<ul style="list-style-type: none"> <li>- 1 NO + 1NC</li> <li>- Flange mount</li> <li>- Faston 250 (6.3 x 0.8 mm)</li> </ul>	<ul style="list-style-type: none"> <li>- 1 NO + 1NC</li> <li>- P.C.B. mounting</li> </ul>
<p>14 22 11 21 a b A1 A2</p> <p>32.2 3.6 36.5 52.2 42.2 9.6 9.1 14 9.1 12.6 13 6.3 4.6</p>	<p>14 22 11 21 a b A1 A2</p> <p>32.2 68 46 9.1 46 68 4.6 6.3 10.7 4.6 10.3 36.5</p> <p>h = 46 mm</p>
1 NO + 1 NC	1 NO + 1 NC
20/40	20/40
250/400*	250/400*
5,000	5,000
1,000	1,000
1.1	1.1
20/0.8/0.5	20/0.8/0.5
1,000 (10/10)	1,000 (10/10)
AgCdO	AgCdO
6 - 12 - 24 - 48 - 60 - 110 - 120 - 230 - 240	
6 - 12 - 24 - 48 - 60 - 110	
2.2/1.3	2.2/1.3
(0.8...1.1)U <sub>N</sub>	(0.8...1.1)U <sub>N</sub>
(0.85...1.1)U <sub>N</sub>	(0.85...1.1)U <sub>N</sub>
0.8 U <sub>N</sub> /0.6 U <sub>N</sub>	0.8 U <sub>N</sub> /0.6 U <sub>N</sub>
0.2 U <sub>N</sub> /0.1 U <sub>N</sub>	0.2 U <sub>N</sub> /0.1 U <sub>N</sub>
10 · 10 <sup>6</sup> /30 · 10 <sup>6</sup>	10 · 10 <sup>6</sup> /30 · 10 <sup>6</sup>
80 · 10 <sup>3</sup>	80 · 10 <sup>3</sup>
20/20	20/20
4 kV/3	4 kV/3
4	4
1,500	1,500
-40...+50	-40...+50
RT I	RT I

- P.C.B. or Faston 250 versions
- AC or DC coils
- 3 mm gap between open contacts on NO version

### 65.31 - 0300

### 65.61 - 0300



- 1 NO
- Flange mount
- Faston 250 (6.3 x 0.8 mm)

- 1 NO
- P.C.B. mounting

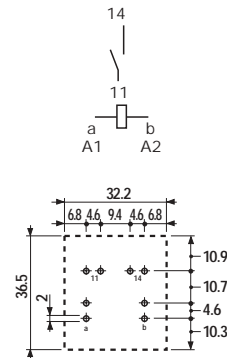
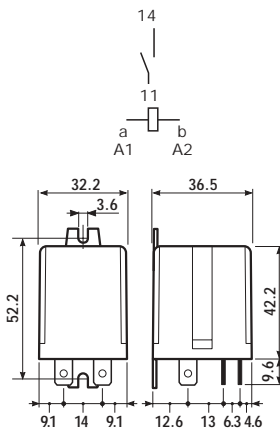

Copper side view  
h = 42 mm

\* for 400 V applications, requirements for pollution degree 2 are met.

\*\* Distance between contacts >3mm (EN 60335-1)

Contact specifications			
Contact configuration			1 NO 3 mm**
Rated current/Maximum peak current	A	30/50	30/50
Rated voltage/Maximum switching voltage	V AC	250/400*	250/400*
Rated load in AC1	VA	7,500	7,500
Rated load in AC15 (230 VAC)	VA	1,250	1,250
Single phase motor rating (230 VAC)	kW	1.5	1.5
Breaking capacity in DC1: 30/110/220V	A	30/1.1/0.7	30/1.1/0.7
Minimum switching load	mW (V/mA)	1,000 (10/10)	1,000 (10/10)
Standard contact material		AgCdO	AgCdO
Coil specifications			
Nominal voltage (U <sub>N</sub> )	V AC (50/60 Hz)	6 - 12 - 24 - 48 - 60 - 110 - 120 - 230 - 240	
	V DC	6 - 12 - 24 - 48 - 60 - 110	
Rated power AC/DC	VA (50 Hz)/W	2.2/1.3	2.2/1.3
Operating range	AC (50 Hz)	(0.8...1.1)U <sub>N</sub>	
	DC	(0.85...1.1)U <sub>N</sub>	
Holding voltage	AC/DC	0.8 U <sub>N</sub> /0.6 U <sub>N</sub>	
Must drop-out voltage	AC/DC	0.2 U <sub>N</sub> /0.1 U <sub>N</sub>	
Technical data			
Mechanical life AC/DC	cycles	10 · 10 <sup>6</sup> /30 · 10 <sup>6</sup>	
Electrical life at rated load AC1	cycles	50 · 10 <sup>3</sup>	
Operate/release time (bounce included)	ms	25/—	
Insulation according to EN 61810-5		4 kV/3	
Insulation between coil and contacts (1.2/50µs)		4	
Dielectric strength between open contacts		2,500 V AC	
Ambient temperature range		-40...+50 °C	
Environmental protection		RT I	
<b>Approvals:</b> (according to type)			

## ORDERING INFORMATION

Example: a 65 series power relay, for P.C.B. with bifurcated terminals, 1 NC + 1 NO contact with a 12 V DC coil.

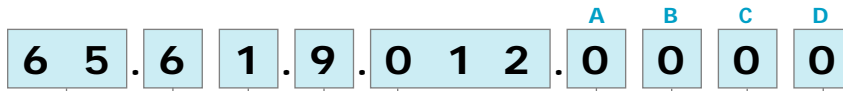

**Series**

**Type**

3 = Faston 250 (6.3x0.8 mm) with rear flange mount  
6 = P.C.B. with bifurcated terminals

**No. of poles**

1 = 1 NC + 1 NO

**Coil version**

8 = AC (50/60 Hz)  
9 = DC

**Coil voltage**

see coil specifications

**A: Contact material**

0 = Standard AgCdO

**B: Contact circuit**

0 = 1 NO + 1 NC  
3 = NO ( $\geq 3$  mm contact gap)

**D: Special versions**

0 = Standard  
5 = Top flange mount  
7 = Top 35 mm rail (EN 50022) mount  
8 = Rear 35 mm rail (EN 50022) mount

**C: Options**

0 = None

**Only combinations in the same row are possible**

Preferred versions

	coil version	A	B	C	D
65.31	AC-DC	0	0	0	0
65.61	AC-DC	0	0	0	0

All versions

	coil version	A	B	C	D
65.31	AC-DC	0	0 - 3	0	0-5-7-8
65.61	AC-DC	0	0 - 3	0	0

65

## POSSIBLE OPTIONS

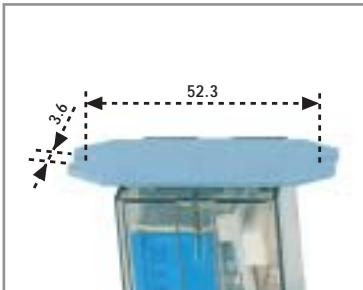

Option = 0005  
TOP FLANGE MOUNT



Option = 0008  
REAR 35 mm RAIL MOUNT

## TECHNICAL DATA

### INSULATION

INSULATION according to EN 61810-5	insulation rated voltage	V	250
	rated impulse withstand voltage	kV	4
	pollution degree		3
	overvoltage category		III

### IMMUNITY

CONDUCTED DISTURBANCE IMMUNITY	BURST (according to EN 61000-4-4) level 4 (4kV)
	SURGE (according to EN 61000-4-5) level 4 (4kV)

### OTHER DATA

VIBRATION RESISTANCE (10...55Hz): NO/NC	g/g	10/4	
POWER LOST TO THE ENVIRONMENT	<b>1 NO + 1 NC</b>		
	without contact current	W	1.3
	with rated current	W	2.1
RECOMMENDED DISTANCE between RELAYS mounted on P.C.B.s	mm	$\geq 5$	



## CONTACT SPECIFICATIONS

### F 65

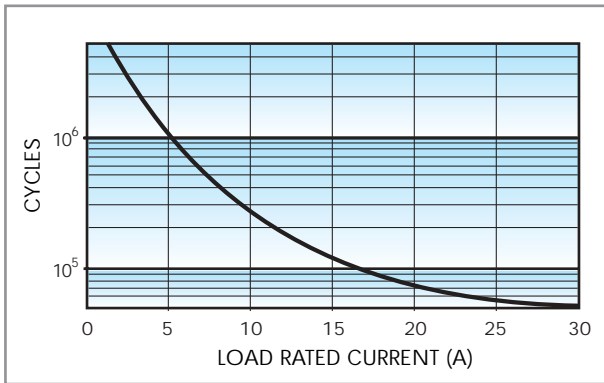

Electrical life vs AC1 load.

### H 65

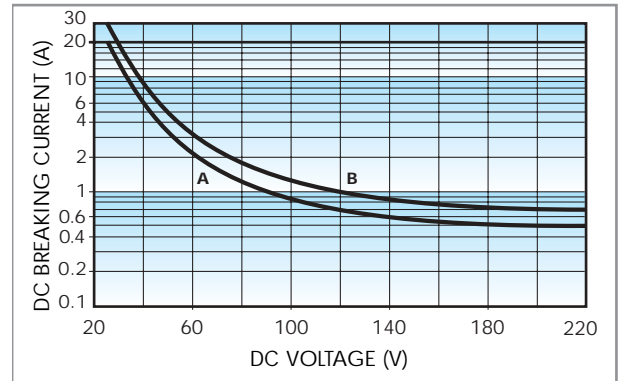

Breaking capacity for DC1 load.

Load applied to 1 contact

**A** - 1 NO + 1 NC type

**B** - 1 NO type

- When switching a resistive load (DC1) having voltage and current values under the curve the expected electrical life is  $\geq 100 \cdot 10^3$  cycles.

- In case of DC13 loads the connection of a diode in parallel with the load will permit the same electrical life as for a DC1 load.

**Note:** the release time of load will be increase.

65

## COIL SPECIFICATIONS

### AC VERSION DATA

Nominal voltage $U_N$ V	Coil code	Operating range		Resistance R $\Omega$	Rated coil consumption I at $U_N$ (50Hz) mA
		$U_{min}$ V	$U_{max}$ V		
6	8.006	4.8	6.6	4.6	367
12	8.012	9.6	13.2	19	183
24	8.024	19.2	26.4	74	90
48	8.048	38.4	52.8	290	47
60	8.060	48	66	450	37
110	8.110	88	121	1,600	20
120	8.120	96	132	1,940	18.6
230	8.230	184	253	7,250	10.5
240	8.240	192	264	8,500	9.2

### DC VERSION DATA

Nominal voltage $U_N$ V	Coil code	Operating range		Resistance R $\Omega$	Rated coil consumption I at $U_N$ mA
		$U_{min}$ V	$U_{max}$ V		
6	9.006	5.1	6.6	28	214
12	9.012	10.2	13.2	110	109
24	9.024	8.8	26.4	445	54
48	9.048	40.8	52.8	1,770	27.1
60	9.060	51	66	2,760	21.7
110	9.110	93.5	121	9,420	11.7

### R 65 AC

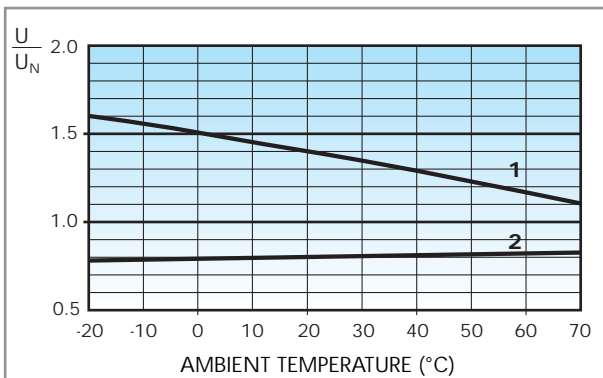

Operating range (AC type) vs ambient temperature.

1 - Max coil voltage permitted.

2 - Min pick-up voltage with coil at ambient temperature.

### R 65 DC

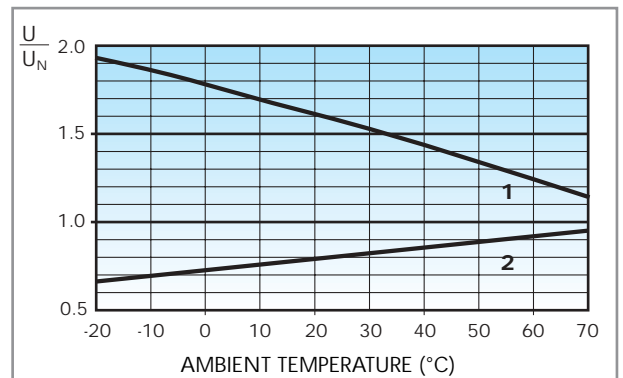

Operating range (DC type) vs ambient temperature.

1 - Max coil voltage permitted.

2 - Min pick-up voltage with coil at ambient temperature.

## 19.21

- 3 functions selector switch:
  - Auto (works as a monostable relay)
  - Off (relay permanently OFF)
  - On (relay permanently ON)
- LED indicator
- 35 mm rail (EN 50022) mount



- One module (11.2 mm) wide
- 1 pole
- 35 mm rail mount

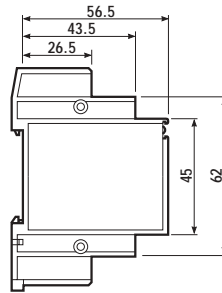
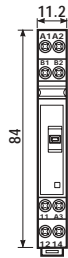

Contact specifications		
Contact configuration		1 CO
Rated current/Max. peak current	A	10/15
Rated voltage/Max. switching voltage	V AC	250/400
Rated load in AC1	VA	2,500
Rated load in AC15 (230 VAC)	VA	500
Single phase motor rating (230 VAC)	kW	0.44
Breaking capacity in DC1: 30/110/220V	A	10/0.3/0.12
Minimum switching load	mW (V/mA)	1,000 (10/10)
Standard contact material		AgCdO
Supply specifications		
Nominal voltage	V AC (50/60Hz)	24
	V DC	24
Rated power AC/DC	VA (50Hz)/W	0.6/0.4
Operating range	V AC (50Hz)/W	(0.8...1.1)U <sub>N</sub>
	V DC	(0.8...1.1)U <sub>N</sub>
Technical data		
Mechanical life	cycles	10 · 10 <sup>6</sup>
Electrical life at rated load in AC1	cycles	100 · 10 <sup>3</sup>
Insulation between coil and contacts (1.2/50μs)	kV	4
Dielectric strength between open contacts	V AC	1,000
Ambient temperature range	°C	-10...+50
Protection category		IP 20
<b>Approvals:</b> (according to type)		<b>CE</b>

## ORDERING INFORMATION

Example: a 19 series relay modular Auto-Off-On with 1 CO - 10 A contact, rated at 24 V AC/DC supply.

1 9 . 2 1 . 0 . 0 2 4 . 0 0 0 0

**Series** \_\_\_\_\_

**Type** \_\_\_\_\_

2 = 35 mm rail (EN 50022) mount, 11.2 mm

**No. of poles** \_\_\_\_\_

1 = 1 pole

**Supply voltage**

024 = 24 V

**Supply version**

0 = AC (50/60 Hz)/DC

## TECHNICAL DATA

### CONTACT SPECIFICATIONS

NOMINAL RATE LAMPS		
- incandescence (230V)	W	1,000
- compensated fluorescent (230V)	W	350
- uncompensated fluorescent (230V)	W	500
- halogens (230V)	W	1,000

### INSULATION

DIELECTRIC STRENGTH		
- between supply and contacts	V AC	3,000
- between open contacts	V AC	1,000

### OTHER DATA

POWER LOST TO THE ENVIRONMENT		
- without contact current	W	0.4
- with rated current	W	1.8
MAX WIRE SIZE	solid cable	
	mm <sup>2</sup>	1x6 / 2x2.5
	AWG	1x10 / 2x14
		stranded cable
		1x4 / 2x1.5
		1x12 / 2x16
SCREW TORQUE	Nm	0.5

## WIRING DIAGRAM

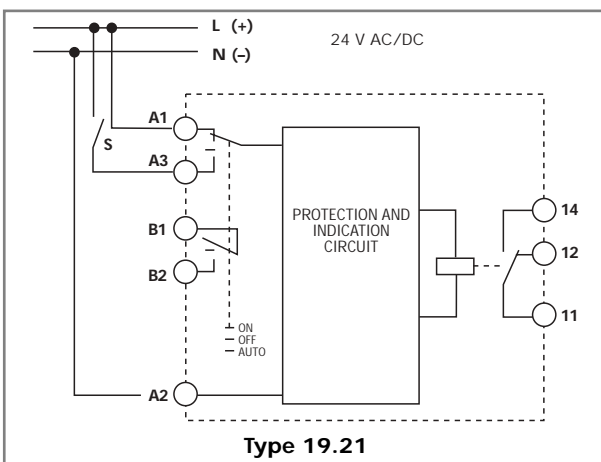

The max switching voltage between B<sub>1</sub> and B<sub>2</sub> terminal is 24 V AC/DC (300mA).

## SELECTOR POSITION

Selector switch	Control switch (S)	Output relay	LED	B <sub>1</sub> -B <sub>2</sub> contact
<b>AUTO</b>	<b>Closed</b>	<b>ON</b>	<b>ON</b>	<b>Closed</b>
	<b>Open</b>	<b>OFF</b>	<b>OFF</b>	<b>Closed</b>
<b>ON</b>	—	<b>ON</b>	<b>ON</b>	<b>Open</b>
<b>OFF</b>	—	<b>OFF</b>	<b>OFF</b>	<b>Open</b>

The B<sub>1</sub> - B<sub>2</sub> contact signals when the selector switch is in the Auto position. The LED indicates the state of the Modular relay's output contacts.

## ACCESSORIES

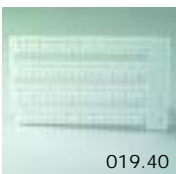

**Sheet of marker tags (40 tags)**

019.40

019.40

- Relay interface modules for use with PLC systems, 6.2 mm wide
- Sensitive DC coil or AC/DC coil version
- Supplied with integral coil indication and protection circuit
- Instant removal of relay using plastic retaining clip
- 35 mm rail (EN 50022) mounting

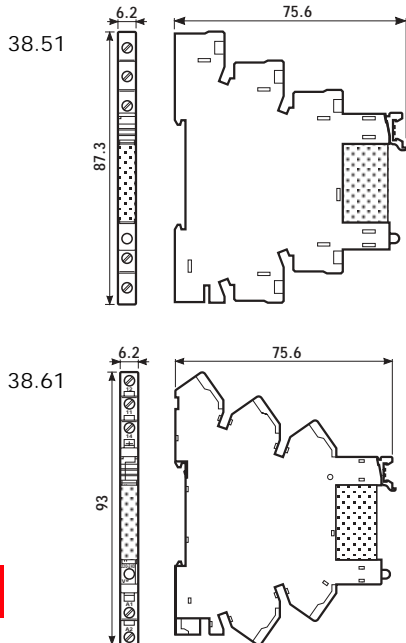
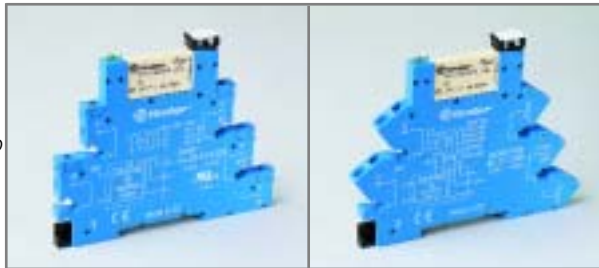
**38.51**
**38.61**

- Screw terminal
- Electromechanical relay
- 35 mm rail mounting

- Screw less terminal
- Electromechanical relay
- 35 mm rail mounting

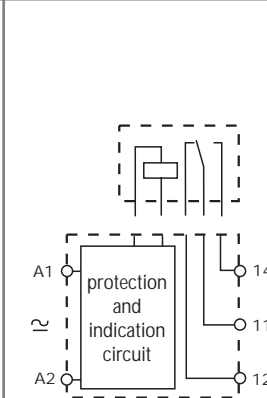
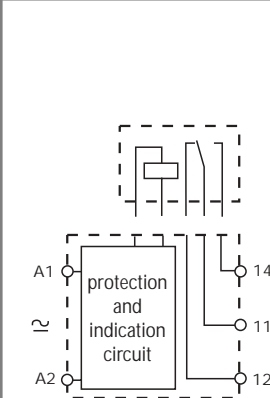

Contact specifications			
Contact configuration		1 CO	1 CO
Rated current/Maximum peak current	A	6/10	6/10
Rated voltage/Maximum switching voltage	V AC	250/400*	250/400*
Rated load in AC1	VA	1,500	1,500
Rated load in AC15 (230 VAC)	VA	300	300
Single phase motor rating (230 VAC)	kW	—	—
Breaking capacity in DC1: 30/110/220V	A	6/0.2/0.15	6/0.2/0.15
Minimum switching load	mW (V/mA)	500 (12/10)	500 (12/10)
Standard contact material		AgNi	AgNi
Coil specifications			
Nominal voltage (U <sub>N</sub> )	V DC/AC (50/60 Hz)	12 · 24 · 48 · 60 · 110...125 · 230...240	
	V DC	6 · 12 · 24 · 48 · 60	
Rated power AC/DC	VA (50 Hz)/W	see table page 81	see table page 81
Operating range	AC/DC (50 Hz)	see table page 81	see table page 81
	DC	see table page 81	see table page 81
Holding voltage	AC/DC	0.6 U <sub>N</sub> /0.6 U <sub>N</sub>	0.6 U <sub>N</sub> /0.6 U <sub>N</sub>
Must drop-out voltage	AC/DC	0.1 U <sub>N</sub> /0.05 U <sub>N</sub>	0.1 U <sub>N</sub> /0.05 U <sub>N</sub>
Technical data			
Mechanical life AC/DC	cycles	—/10 · 10 <sup>6</sup>	—/10 · 10 <sup>6</sup>
Electrical life at rated load AC1	cycles	60 · 10 <sup>3</sup>	60 · 10 <sup>3</sup>
Operate/release time (bounce included)	ms	7/11	7/11
Insulation according to EN 61810-5		3.6 kV/3	3.6 kV/3
Insulation between coil and contacts (1.2/50µs)	kV	6 (8mm)	6 (8mm)
Dielectric strength between open contacts	V AC	1,000	1,000
Ambient temperature range (AC/DC)/(DC)	°C	-40...+55/-40...+70	-40...+55/-40...+70
Protection category		IP20	IP20
Approvals (relay): (according to type)			

\* for 400 V applications, requirements for pollution degree 2 are met.

- Relay interface modules for use with PLC systems, 6.2 mm wide
- Sensitive DC coil or AC/DC coil version
- Supplied with integral coil indication and protection circuit
- Instant removal of relay using plastic retaining clip
- 35 mm rail (EN 50022) mounting

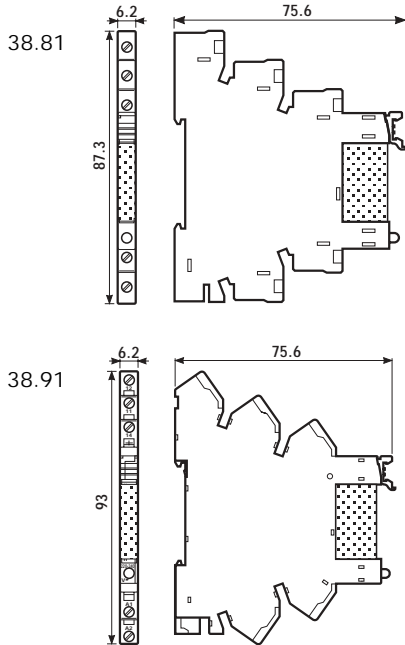

	38.81	38.91	
	<ul style="list-style-type: none"> <li>- Screw terminal</li> <li>- SSR relay</li> <li>- 35 mm rail mounting</li> </ul>	<ul style="list-style-type: none"> <li>- Screwless terminal</li> <li>- SSR relay</li> <li>- 35 mm rail mounting</li> </ul>	
<b>Output circuit</b>			
Maximum switching current	A	2      0,1	2      0,1
Rated voltage	V DC	24      48	24      48
Switching voltage range	V DC	0...24    0...48	0...24    0...48
Maximum blocking voltage	V DC	33      60	33      60
<b>Input circuit</b>			
Nominal voltage	V DC	24 - 60	24 - 60
Operating range	V DC	see table page 80	see table page 80
Control current	mA	see table page 80	see table page 80
Release voltage	V DC	see table page 80	see table page 80
<b>Technical data</b>			
Dielectric strength between input/output	V	2500	2500
Ambient temperature range	°C	-20...+55	-20...+55
Protection category		IP20	IP20
<b>Approvals:</b> (according to type)		—	—

## ORDERING INFORMATION

### ELECTROMECHANICAL RELAY (EMR)

Example: a 38 series relay interface module with 1 CO contact, with coil rated at 12 V DC.

<p><b>Series</b> ———</p> <p><b>Type</b> ———</p> <p>5 = Electromechanical relay, with screw terminal 6 = Electromechanical relay, with screwless terminal</p> <p><b>No. of poles</b> ———</p> <p>1 = 1 pole, 6 A</p> <p><b>Coil version</b> ———</p> <p>0 = AC (50/60 Hz)/ DC 7 = Sensitive DC</p> <p><b>Coil voltage</b> ———</p> <p>see coil specifications</p>	<div style="display: flex; justify-content: space-around; align-items: center;"> <div style="border: 1px solid black; padding: 5px; margin: 2px;">3</div> <div style="border: 1px solid black; padding: 5px; margin: 2px;">8</div> <div style="border: 1px solid black; padding: 5px; margin: 2px;">.</div> <div style="border: 1px solid black; padding: 5px; margin: 2px;">5</div> <div style="border: 1px solid black; padding: 5px; margin: 2px;">.</div> <div style="border: 1px solid black; padding: 5px; margin: 2px;">1</div> <div style="border: 1px solid black; padding: 5px; margin: 2px;">.</div> <div style="border: 1px solid black; padding: 5px; margin: 2px;">7</div> <div style="border: 1px solid black; padding: 5px; margin: 2px;">.</div> <div style="border: 1px solid black; padding: 5px; margin: 2px;">0</div> <div style="border: 1px solid black; padding: 5px; margin: 2px;">1</div> <div style="border: 1px solid black; padding: 5px; margin: 2px;">2</div> <div style="border: 1px solid black; padding: 5px; margin: 2px;">.</div> <div style="border: 1px solid black; padding: 5px; margin: 2px;">0</div> <div style="border: 1px solid black; padding: 5px; margin: 2px;">.</div> <div style="border: 1px solid black; padding: 5px; margin: 2px;">0</div> <div style="border: 1px solid black; padding: 5px; margin: 2px;">.</div> <div style="border: 1px solid black; padding: 5px; margin: 2px;">0</div> <div style="border: 1px solid black; padding: 5px; margin: 2px;">.</div> <div style="border: 1px solid black; padding: 5px; margin: 2px;">5</div> <div style="border: 1px solid black; padding: 5px; margin: 2px;">.</div> <div style="border: 1px solid black; padding: 5px; margin: 2px;">0</div> </div>	<p><b>A: Contact material</b></p> <p>0 = AgNi Standard 4 = AgSnO<sub>2</sub> 5 = AgNi + Au</p> <p><b>B: Contact circuit</b></p> <p>0 = CO</p> <p><b>D: Special versions</b></p> <p>0 = Standard</p> <p><b>C: Options</b></p> <p>5 = Standard DC (positive A1) 6 = Standard AC/DC</p>
---	---	--

### SOLID STATE RELAY (SSR)

Example: a 38 series SSR relay interface module with 2 A, with 24 V DC supply.

<p><b>Series</b> ———</p> <p><b>Type</b> ———</p> <p>8 = SSR relay, with screw terminal 9 = SSR relay, with screwless terminal</p> <p><b>Output</b> ———</p> <p>1 = 1 NO</p> <p><b>Control circuit</b> ———</p> <p>see input specifications</p>	<div style="display: flex; justify-content: space-around; align-items: center;"> <div style="border: 1px solid black; padding: 5px; margin: 2px;">3</div> <div style="border: 1px solid black; padding: 5px; margin: 2px;">8</div> <div style="border: 1px solid black; padding: 5px; margin: 2px;">.</div> <div style="border: 1px solid black; padding: 5px; margin: 2px;">8</div> <div style="border: 1px solid black; padding: 5px; margin: 2px;">.</div> <div style="border: 1px solid black; padding: 5px; margin: 2px;">1</div> <div style="border: 1px solid black; padding: 5px; margin: 2px;">.</div> <div style="border: 1px solid black; padding: 5px; margin: 2px;">7</div> <div style="border: 1px solid black; padding: 5px; margin: 2px;">.</div> <div style="border: 1px solid black; padding: 5px; margin: 2px;">0</div> <div style="border: 1px solid black; padding: 5px; margin: 2px;">.</div> <div style="border: 1px solid black; padding: 5px; margin: 2px;">2</div> <div style="border: 1px solid black; padding: 5px; margin: 2px;">.</div> <div style="border: 1px solid black; padding: 5px; margin: 2px;">4</div> <div style="border: 1px solid black; padding: 5px; margin: 2px;">.</div> <div style="border: 1px solid black; padding: 5px; margin: 2px;">9</div> <div style="border: 1px solid black; padding: 5px; margin: 2px;">.</div> <div style="border: 1px solid black; padding: 5px; margin: 2px;">0</div> <div style="border: 1px solid black; padding: 5px; margin: 2px;">.</div> <div style="border: 1px solid black; padding: 5px; margin: 2px;">2</div> <div style="border: 1px solid black; padding: 5px; margin: 2px;">.</div> <div style="border: 1px solid black; padding: 5px; margin: 2px;">4</div> </div>	<p><b>Output circuit</b></p> <p>9024 = 2 A - 24 V DC 7048 = 100 mA - 48 V DC</p>
---	---	--

38

## SOLID STATE RELAY

### OTHER DATA

POWER LOST TO THE ENVIRONMENT	without contact current	W	0.17	
	with rated current	W	0.4	
WIRE STRIP LENGTH		mm	10	
			<b>38.81</b>	<b>38.91</b>
⊖ SCREW TORQUE		Nm	0.5	
MAX WIRE SIZE			solid cable	stranded cable
		mm <sup>2</sup>	1x2.5 / 2x1.5	1x2.5 / 2x1.5
		AWG	1x14 / 2x16	1x14 / 2x16

## INPUT SPECIFICATION

### DC VERSION DATA

Nominal voltage U <sub>N</sub>	Supply code	Operating range		Release voltage V	Control current I at U <sub>N</sub> mA
		U <sub>min</sub> V	U <sub>max</sub> V		
24	7.024	16.8	30	10	7
60	7.060	35.6	72	20	3

# ELECTROMECHANICAL RELAY

## TECHNICAL DATA

### INSULATION

INSULATION according to EN 61810-5	insulation rated voltage	V	250
	rated impulse withstand voltage	kV	3.6
	pollution degree		3
	overvoltage category		III

### IMMUNITY

CONDUCTED DISTURBANCE IMMUNITY	BURST (according to EN 61000-4-4) level 4 (4kV)
	SURGE (according to EN 61000-4-5) level 3 (2kV)

### OTHER DATA

VIBRATION RESISTANCE (10...55Hz): NO/NC	g/g	10/5			
POWER LOST TO THE ENVIRONMENT	without contact current	W	0.2 (12V) - 0.9 (240V)		
	with rated current	W	0.5 (12V) - 1.5 (240V)		
WIRE STRIP LENGTH	mm	10			
			<b>38.51</b>		<b>38.61</b>
⊖ SCREW TORQUE	Nm	0.5		—	
MAX WIRE SIZE		solid cable	stranded cable	solid cable	stranded cable
		mm <sup>2</sup>	1x2.5 / 2x1.5	1x2.5 / 2x1.5	1x2.5 / 1x2.5
		AWG	1x14 / 2x16	1x14 / 2x16	1x14 / 1x14

**38**

## CONTACT SPECIFICATIONS

### F 38

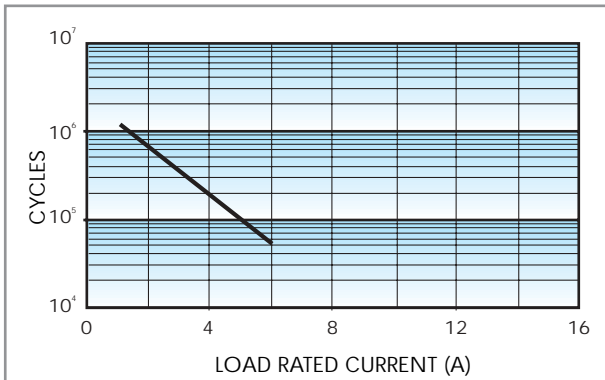

Electrical life vs AC1 load.

### H 38

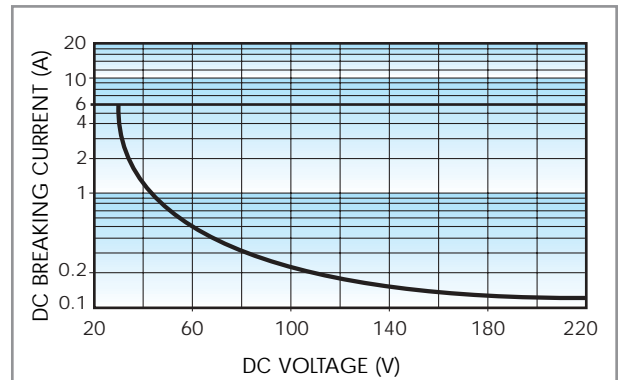

Breaking capacity in DC1 load.

- When switching a resistive load (DC1) having voltage and current values under the curve the expected electrical life is  $\geq 100 \cdot 10^3$  cycles.
  - In case of DC13 loads the connection of a diode in parallel with the load will permit the same electrical life as for a DC1 load.
- Note:** the release time of load will be increase.

## ELECTROMECHANICAL RELAY

### COIL SPECIFICATIONS

#### AC/DC VERSION DATA

Nominal voltage $U_N$ V	Coil code	Operating range		Rated coil consumption I at $U_N$ mA	Power consumption P at $U_N$ W
		$U_{min}$ V	$U_{max}$ V		
12	<b>0.012</b>	9.8	13.2	19	0.2
24	<b>0.024</b>	19.2	26.4	12	0.3
48	<b>0.048</b>	38.4	52.8	9	0.4
60	<b>0.060</b>	48	66	7	0.5
110...125	<b>0.125</b>	88	138	5(*)	0.6(*)
230...240	<b>0.240</b>	184	264	4(*)	0.9(*)

#### DC VERSION DATA (sensitive)

Nominal voltage $U_N$ V	Coil code	Operating range		Rated coil consumption I at $U_N$ mA
		$U_{min}$ V	$U_{max}$ V	
6	<b>7.006</b>	5	7.2	48.1
12	<b>7.012</b>	9.8	14.4	15.2
24	<b>7.024</b>	18.2	28.8	9.4
48	<b>7.048</b>	35	57.6	6.3
60	<b>7.060</b>	43.5	72	5.2

(\*) Rated coil consumption and power consumption values relate to  $U_N = 125$  and  $240$  V.

### R 38

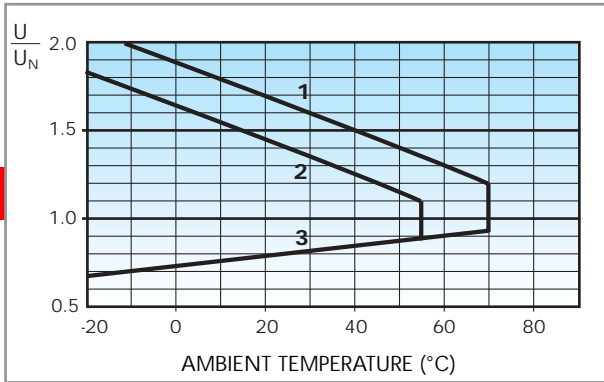

Operating range Vs ambient temperature.

- 1** - Max coil voltage permitted at nominal load (DC version).
- 2** - Max coil voltage permitted at nominal load (AC/DC version).
- 3** - Min pick-up voltage with coil at ambient temperature.

38





**COMBINATION FOR ELECTROMECHANICAL RELAY**

Code	Supply voltage	Type of relay	Type of socket
38.51.0.012.0060	12 V AC/DC	34.51.7.012.0010	93.01.0.024
<b>38.51.0.024.0060</b>	24	628.304 64.044 628.30424 7 73.65233c73. 0.014.5953 02gs-0.000131.8(93per li24))TJE96 4	

## ACCESSORIES

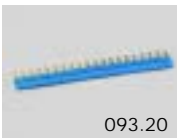

- RATED VALUES: 36 A - 250 V

<b>20-way jumper link</b> for 38 series	093.20
---	--------

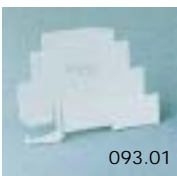
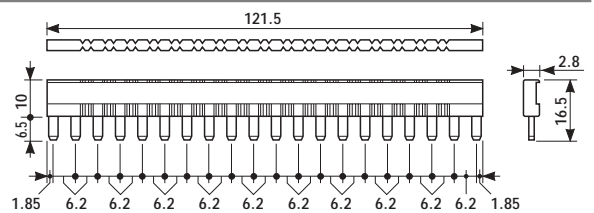

<b>Plastic separator</b>	093.01
--------------------------	--------

Thickness 2mm, required at the start and the end of a group of interfaces.  
 Can be used for visual separation group, must be used for:

- protective separation of different voltages of neighbouring PLC interfaces according to VDE 0106-101
- protection of cut jumper links

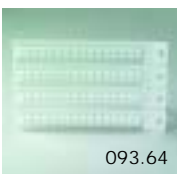

<b>Sheet of marker tags (64 tags)</b>	093.64
---------------------------------------	--------

- Relay interface modules for use with PLC systems, 15.8 mm wide
- AC or sensitive DC coil versions available
- Instant removal of relay using plastic retaining clip
- Supply status indication or coil suppression module provided
- Identification label
- 35 mm rail (EN 50022) mounting

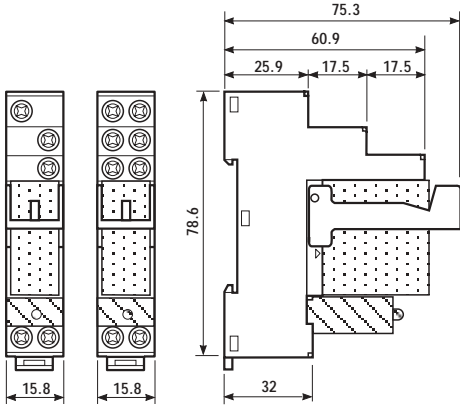

48.31 48.52/61

\* for 400 V applications, requirements for pollution degree 2 are met.

48

### Contact specifications

		48.31	48.52	48.61
Contact configuration		1 CO	2 CO	1 CO
Rated current/Maximum peak current	A	10/20	8/15	16/30
Rated voltage/Maximum switching voltage	V AC	250/400*	250/250	250/400*
Rated load in AC1	VA	2,500	2,000	4,000
Rated load in AC15 (230 VAC)	VA	500	400	750
Single phase motor rating (230 VAC)	kW	0.37	0.3	0.55
Breaking capacity in DC1: 30/110/220V	A	10/0.3/0.12	8/0.3/0.12	16/0.3/0.12
Minimum switching load	mW (V/mA)	300 (5/5)	300 (5/5)	500 (10/5)
Standard contact material		AgNi	AgNi	AgCdO

### Coil specifications

		48.31	48.52	48.61
Nominal voltage (U <sub>N</sub> )	V AC (50/60 Hz)	12 - 24 - 110 - 120 - 230	12 - 24 - 110 - 120 - 230	12 - 24 - 110 - 120 - 230
	V DC	12 - 24 - 125	12 - 24 - 125	12 - 24 - 125
Rated power AC/sens. DC	VA (50 Hz)/W	1.2/0.5	1.2/0.5	1.2/0.5
Operating range	AC (50 Hz)	(0.8...1.1)U <sub>N</sub>	(0.8...1.1)U <sub>N</sub>	(0.8...1.1)U <sub>N</sub>
	sens. DC	(0.73...1.5)U <sub>N</sub>	(0.73...1.5)U <sub>N</sub>	(0.8...1.5)U <sub>N</sub>
Holding voltage	AC/DC	0.8 U <sub>N</sub> / 0.4 U <sub>N</sub>	0.8 U <sub>N</sub> / 0.4 U <sub>N</sub>	0.8 U <sub>N</sub> / 0.4 U <sub>N</sub>
Must drop-out voltage	AC/DC	0.2 U <sub>N</sub> / 0.1 U <sub>N</sub>	0.2 U <sub>N</sub> / 0.1 U <sub>N</sub>	0.2 U <sub>N</sub> / 0.1 U <sub>N</sub>

### Technical data

Mechanical life AC/DC	cycles	10 · 10 <sup>6</sup> /20 · 10 <sup>6</sup>	10 · 10 <sup>6</sup> /—	10 · 10 <sup>6</sup> /20 · 10 <sup>6</sup>
Electrical life at rated load AC1	cycles	200 · 10 <sup>3</sup>	150 · 10 <sup>3</sup>	100 · 10 <sup>3</sup>
Operate/release time (bounce included)	ms	10/10 · (15/12 sens.)	10/10 · (15/12 sens.)	10/10 · (15/12 sens.)
Insulation according to EN 61810-5		3.6 kV/3	3.6 kV/2	3.6 kV/3
Insulation between coil and contacts (1.2/50μs)	kV	6 (8mm)	6 (8mm)	6 (8mm)
Dielectric strength between open contacts	V AC	1,000	1,000	1,000
Ambient temperature range	°C	-40...+70	-40...+70	-40...+70
Protection category		IP 20	IP 20	IP 20

**Approvals (relay):** (according to type)



48.31	48.52	48.61
 - 1 pole, 10 A - 35 mm rail mounting	 - 2 pole, 8 A - 35 mm rail mounting	 - 1 pole, 16 A - 35 mm rail mounting

- Relay interface modules for use with PLC systems, 15.8 mm wide
- AC or sensitive DC coil versions available
- Instant removal of relay using plastic retaining clip
- Supply status indication or coil suppression module provided
- Identification label
- 35 mm rail (EN 50022) mounting

### 48.62



- 2 pole, 10 A
- 35 mm rail mounting

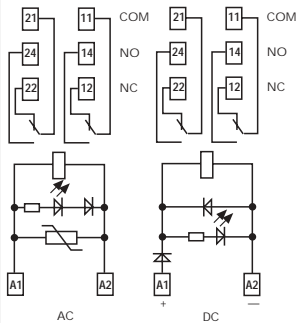
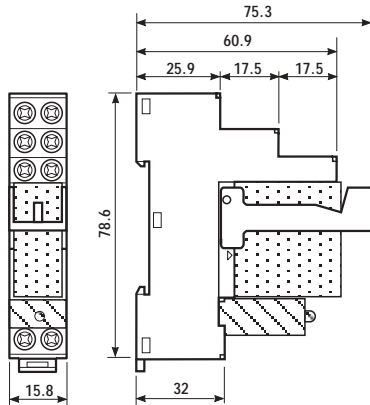

\* for 400 V applications requirements for pollution degree 2 are met.

Contact specification	
Contact configuration	2 CO
Rated current/Maximum peak current	A 10/20
Rated voltage/Maximum switching voltage	V AC 250/400*
Rated load in AC1	VA 2,500
Rated load in AC15 (230 VAC)	VA 500
Single phase motor rating (230 VAC)	kW 0.37
Breaking capacity in DC1: 30/110/220V	A 10/0.3/0.12
Minimum switching load	mW (V/mA) 300 (5/5)
Standard contact material	AgNi
Coil specifications	
Nominal voltage (U <sub>N</sub> )	V AC (50/60 Hz) —
	V DC 12 · 24 · 125
Rated power AC/sens. DC	VA (50 Hz)/W —/0.5
Operating range	AC (50 Hz) —
	sens. DC (0.8...1.5)U <sub>N</sub>
Holding voltage	AC/DC —/0.8 U <sub>N</sub>
Must drop-out voltage	AC/DC —/0.2 U <sub>N</sub>
Technical data	
Mechanical life AC/DC	cycles —/20 · 10 <sup>6</sup>
Electrical life at rated load AC1	cycles 100 · 10 <sup>3</sup>
Operate/release time (bounce included)	ms 10/10
Insulation according to EN 61810-5	3.6 kV/3
Insulation between coil and contacts (1.2/50µs)	kV 6 (8mm)
Dielectric strength between open contacts	V AC 1,000
Ambient temperature range	°C -40...+70
Protection category	IP 20
<b>Approvals (relay):</b> (according to type)	

## ORDERING INFORMATION

Example: a 48 series 35 mm rail (EN 50022) mount relay interface module with 2 CO - 6 A, coil rated 24 V sensitive DC, green LED + diode.

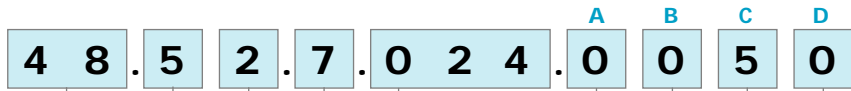

**Series** ———

**Type** ———

- 3 = 35 mm rail mount
- 5 = 35 mm rail mount
- 6 = 35 mm rail mount

**No. of poles** ———

- 1 = 1 pole for 48.31, 10 A  
                    48.61, 16 A
- 2 = 2 pole for 48.52, 8 A  
                    48.62, 10 A, DC only

**Coil version** ———

- 7 = Sensitive DC
- 8 = AC (50/60 Hz)

**Coil voltage** ———

see coil specifications

**A: Contact material**

0 = Standard

**B: Contact circuit**

0 = CO

**D: Special versions**

0 = Standard

**C: Options**

- 5 = Standard for DC:  
    green LED + diode (polarity +A1)
- 6 = Standard for AC:  
    green LED + Varistor

## TECHNICAL DATA

48

### INSULATION

INSULATION according to EN 61810-5	insulation rated voltage	V	250	
	rated impulse withstand voltage	kV	3.6	
	pollution degree		3 (48.31/61/62)	2 (48.52)
	overvoltage category		III	

### IMMUNITY

CONDUCTED DISTURBANCE IMMUNITY	BURST (according to EN 61000-4-4) level 4 (4kV)
	SURGE (according to EN 61000-4-5) level 3 (2kV)

### OTHER DATA

VIBRATION RESISTANCE (10...55Hz): NO/NC	g/g	10/4 (1 CO)	3/3 (2 CO)		
POWER LOST TO THE ENVIRONMENT	without contact current	W	0.7		
	with rated current	W	1.2 (48.31)	1.3 (48.52)	1.2 (48.61)    1.2 (48.62)
WIRE STRIP LENGTH	mm	8			
SCREW TORQUE	Nm	0.5			
MAX WIRE SIZE		solid cable		stranded cable	
	mm <sup>2</sup>	1x6 / 2x2.5		1x4 / 2x2.5	
	AWG	1x10 / 2x14		1x12 / 2x14	

## CONTACT SPECIFICATIONS

### F 48/1

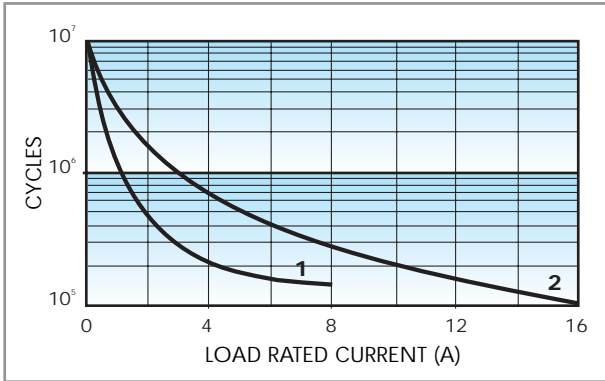

Electrical life vs AC1 load.

- 1 - Type 48.52 (8 A).
- 2 - Type 48.31 (10 A).
- Type 48.61 (16 A).

### F 48/2

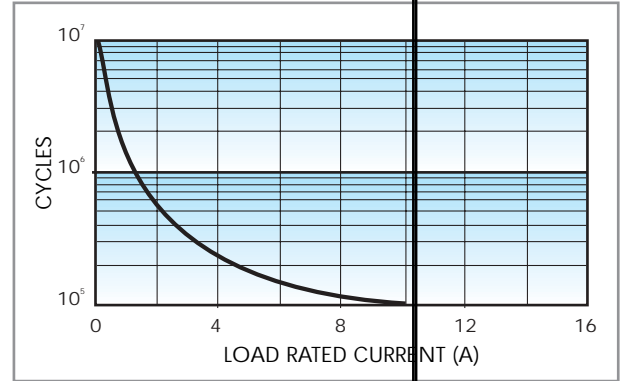

Electrical life vs AC1 load.

Type 48.62 (10 A).

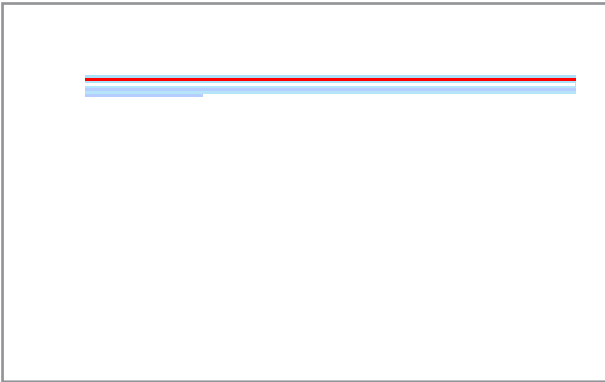

Breaking capacity for DC1 load.

- 1 - Type 48.61.
- 2 - Type 48.31.
- 3 - Type 48.52.
- A - Load applied to 1 contact
- B - Load applied to 2 contacts in series

- When switching a resistive load (DC1) having voltage and current values under the curve the expected electrical life is  $\geq 100 \cdot 10^3$  cycles.

- In case of DC13 loads the connection of a diode in parallel with the load will permit the same electrical life as for a DC1 load.

**Note:** the release time of load will be increase.

### H 48/2

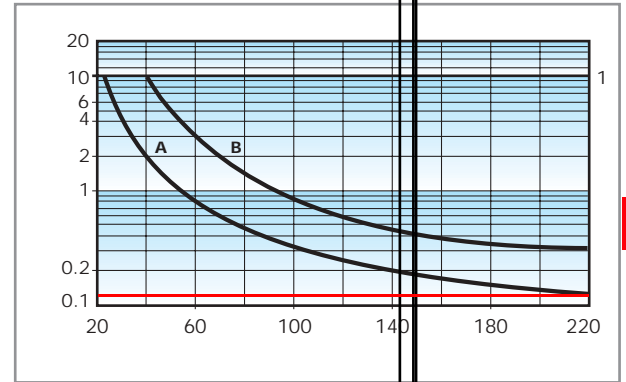

Breaking capacity for DC1 load.

- 1 - Type 48.62.
- A - Load applied to 1 contact
- B - Load applied to 2 contacts in series

- When switching a resistive load (DC1) having voltage and current values under the curve the expected electrical life is  $\geq 100 \cdot 10^3$  cycles.

- In case of DC13 loads the connection of a diode in parallel with the load will permit the same electrical life as for a DC1 load.

**Note:** the release time of load will be increase.

## COIL SPECIFICATIONS

### AC VERSION DATA

Nominal voltage $U_N$ V	Coil code	Operating range		Rated coil consumption I at $U_N$ (50Hz) mA
		$U_{min}$ V	$U_{max}$ V	
12	<b>8.012</b>	9.6	13.2	90.5
24	<b>8.024</b>	19.2	26.4	46
110	<b>8.110</b>	88	121	10.1
120	<b>8.120</b>	96	132	11.8
230	<b>8.230</b>	184	253	60.2

### DC VERSION DATA (0.5 W sensitive)

Nominal voltage $U_N$ V	Coil code	Operating range		Rated coil consumption I at $U_N$ mA
		$U_{min}^*$ V	$U_{max}$ V	
12	<b>7.012</b>	8.8	21	41
24	<b>7.024</b>	17.5	42	22.2
125	<b>7.125</b>	92	218	4

\* $U_{min} = 0.8 U_N$  for 48.61 and 48.62

### R 48 sens. DC

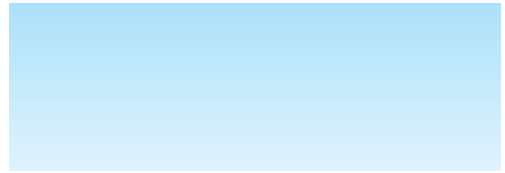

Operating range (AC version) vs ambient temperature.  
**1** - Max coil voltage permitted.  
**2** - Min pick-up voltage with coil at ambient temperature.

Operating range (sensitive DC version) vs ambient temperature.  
**1** - Max coil voltage permitted.  
**2** - Min pick-up voltage with coil at ambient temperature.

## COMBINATIONS

## ACCESSORIES



<b>8-way jumper link</b> for 48 series	095.18
--	--------

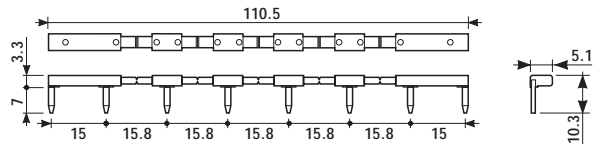

- Relay interface modules for use with PLC systems, 27mm wide
- AC and DC versions available
- Supply status indication and coil suppression module provided
- Identification label
- 35 mm rail (EN 50022) mounting

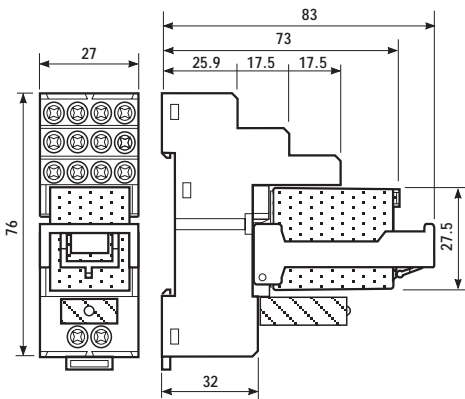

## 58.34



- 4 pole, 5 A
- 35 mm rail mounting

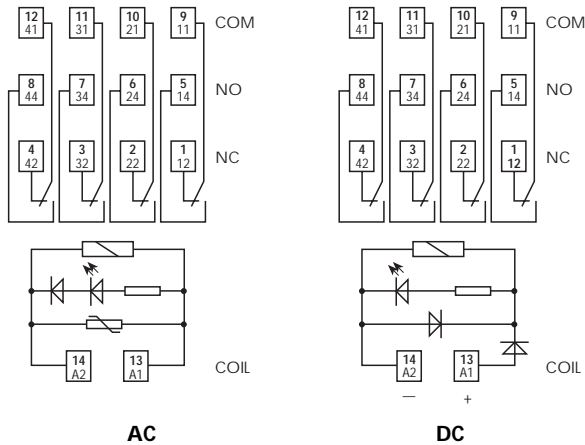

Contact specifications	
Contact configuration	4 CO
Rated current/Maximum peak current      A	5/10
Rated voltage/Maximum switching voltage V AC	250/250
Rated load in AC1                                      VA	1,250
Rated load in AC15 (230 VAC)                      VA	250
Single phase motor rating (230 VAC)           kW	0.125
Breaking capacity in DC1: 30/110/220V        A	5/0.25/0.12
Minimum switching load                            mW (V/mA)	300 (5/5)
Standard contact material	AgNi
Coil specifications	
Nominal voltage (U <sub>N</sub> )                              V AC (50/60 Hz)	12 - 24 - 48 - 110 - 120 - 230
	V DC
	12 - 24 - 48
Rated power AC/DC                                VA (50 Hz)/W	1.5/1
Operating range                                      AC (50 Hz)	(0.8...1.1)U <sub>N</sub>
	DC
	(0.8...1.1)U <sub>N</sub>
Holding voltage                                      AC/DC	0.8 U <sub>N</sub> /0.5 U <sub>N</sub>
Must drop-out voltage                              AC/DC	0.2 U <sub>N</sub> /0.1 U <sub>N</sub>
Technical data	
Mechanical life AC/DC                            cycles	20 · 10 <sup>6</sup> /50 · 10 <sup>6</sup>
Electrical life at rated load AC1                cycles	150 · 10 <sup>3</sup>
Operate/release time (bounce included)      ms	10/20
Insulation according to EN 61810-5	3.6 kV/2
Insulation between coil and contacts (1.2/50µs) kV	3.6
Dielectric strength between open contacts    V AC	1,000
Ambient temperature range                      °C	-40...+70
Protection category	IP 20
Approvals (relay): (according to type)	

## ORDERING INFORMATION

Example: a 58 series 35 mm rail (EN 55022) mounting interface module, 4 CO, 24 V DC coil with green LED + diode.

<b>5</b>	<b>8</b>	<b>.</b>	<b>3</b>	<b>.</b>	<b>4</b>	<b>.</b>	<b>9</b>	<b>.</b>	<b>0</b>	<b>2</b>	<b>4</b>	<b>.</b>	<b>A</b>	<b>B</b>	<b>C</b>	<b>D</b>	
<b>Series</b>		<b>Type</b>		<b>No. of poles</b>		<b>Coil version</b>		<b>Coil voltage</b>		<b>A: Contact material</b>		<b>B: Contact circuit</b>		<b>C: Options</b>		<b>D: Special versions</b>	
		3 = 35mm rail mount		4 = 4 pole, 5 A		8 = AC (50/60 Hz) 9 = DC		see coil specifications		0 = AgNi Standard		0 = CO		5 = Standard DC: green LED + diode (polarity +A1) 6 = Standard AC: green LED + varistor		0 = Standard	

## TECHNICAL DATA

### INSULATION

INSULATION according to EN 61810-5	insulation rated voltage	V	250
	rated impulse withstand voltage	kV	3.6
	pollution degree		2
	overvoltage category		III

### IMMUNITY

CONDUCTED DISTURBANCE IMMUNITY	BURST (according to EN 61000-4-4) level 4 (4kV)
	SURGE (according to EN 61000-4-5) level 4 (4kV)

### OTHER DATA

58

VIBRATION RESISTANCE (10...55Hz): NO/NC	g/g	6/6	
POWER LOST TO THE ENVIRONMENT	without contact current	W	1
	with rated current	W	2.6
WIRE STRIP LENGTH	mm	8	
⊕ SCREW TORQUE	Nm	0.5	
MAX WIRE SIZE	mm <sup>2</sup>	solid cable	stranded cable
		1x6 / 2x2.5	1x4 / 2x2.5
		AWG 1x10 / 2x14	1x12 / 2x14

## CONTACT SPECIFICATIONS

### F 58

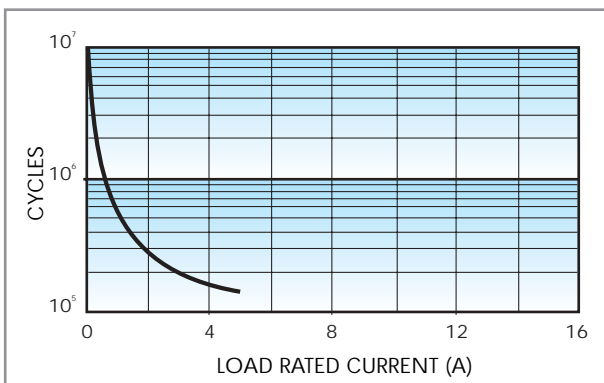

Contact life vs AC1 load.

### H 58

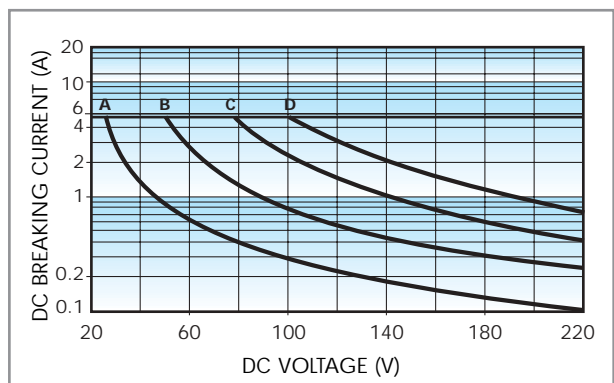

Breaking capacity for DC1 load.

- A** = Load applied to 1 contact;
- B** = Load applied to 2 contacts in series
- C** = Load applied to 3 contacts in series;
- D** = Load applied to 4 contacts in series

- When switching a resistive load (DC1) having voltage and current values under the curve the expected electrical life is  $\geq 100 \cdot 10^3$  cycles.

- In case of DC13 loads the connection of a diode in parallel with the load will permit the same electrical life as for a DC1 load.

**Note:** the release time of load will be increase.





Nominal voltage $U_N$ V	Coil code	Operating range		Resistance R $\Omega$	Rated coil absorption I at $U_N$ (50Hz) mA
		$U_{min}$ V	$U_{max}$ V		
12	<b>8.012</b>	9.6	13.2	50	97
24	<b>8.024</b>	19.2	26.4	190	53
48	<b>8.048</b>	38.4	52.8	770	25
110	<b>8.110</b>	88	121	4,000	12.5
120	<b>8.120</b>	96	132	4,700	12
230	<b>8.230</b>	184	253	17,000	6

## ACCESSORIES



**6-way jumper link** for 58 series 094.06

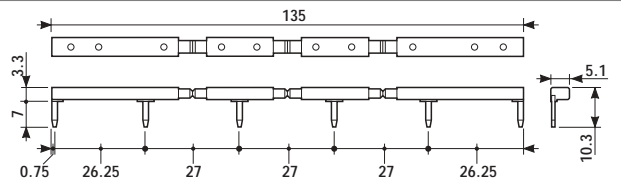

- Mono-function and multi-function versions available
- Rotary selector
- 17.5 mm wide
- Six time scales from 0.1s to 20h
- 35 mm rail (EN 50022) mount
- High input/output insulation

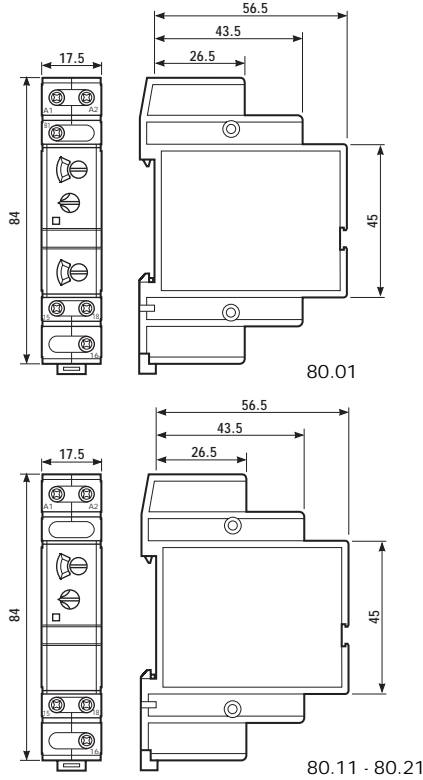

	80.01	80.11	80.21
	- Multi-voltage - Multi-function	- Mono-voltage - Mono-function	- Mono-voltage - Mono-function
	<b>AI:</b> ON delay <b>DI:</b> ON pulse <b>SW:</b> Symmetrical recycler: ON start <b>BE:</b> Signal OFF delay <b>CE:</b> Signal ON and OFF delay <b>DE:</b> Signal ON pulse	<b>AI:</b> ON delay	<b>DI:</b> ON pulse
	 wiring diagram (without signal START)	 wiring diagram (with signal START)	 wiring diagram (without signal START)
<b>80 Contact specifications</b>			
Contact configuration	1 CO	1 CO	1 CO
Rated current/Maximum peak current A	16/30	16/30	16/30
Rated voltage/Maximum switching voltage V AC	250/400	250/400	250/400
Rated load in AC1 VA	4000	4000	4000
Rated load in AC15 (230 VAC) VA	750	750	750
Single phase motor rating (230 VAC) kW	0.55	0.55	0.55
Breaking capacity in DC1: 30/110/220V A	16/0.3/0.12	16/0.3/0.12	16/0.3/0.12
Minimum switching load mW(V/mA)	500 (10/5)	500 (10/5)	500 (10/5)
Standard contact material	AgCdO	AgCdO	AgCdO
<b>Supply specifications</b>			
Nominal voltage V AC(50/60Hz)	12...240	24 - 230...240	24 - 230...240
V DC	12...240 (non polarized)	24	24
Rated power AC/DC VA (50Hz)/W	< 1.8/ < 1.4	< 1.8/ < 0.6	< 1.8/ < 0.6
Operating range AC	10.2...265 V	(0.85...1.1)U <sub>N</sub>	(0.85...1.1)U <sub>N</sub>
DC	10.2...265 V	(0.85...1.1)U <sub>N</sub>	(0.85...1.1)U <sub>N</sub>
<b>Technical data</b>			
Specified time range	(0.1...2) s, (1...20) s, (0.1...2) min, (1...20) min, (0.1...2) h, (1...20) h		
Repeatability %	± 1	± 1	± 1
Recovery time ms	≤ 50	≤ 50	≤ 50
Minimum control impulse ms	50	—	—
Setting accuracy-full range %	± 5	± 5	± 5
Electrical life at rated load in AC1 cycles	100·10 <sup>3</sup>	100·10 <sup>3</sup>	100·10 <sup>3</sup>
Ambient temperature range °C	-10...+50	-10...+50	-10...+50
Protection category	IP 20	IP 20	IP 20
<b>Approvals:</b> (according to type)			

- Mono-function and multi-function versions available
- Rotary selector
- 17.5 mm wide
- Six time scales from 0.1s to 20h
- 35 mm rail (EN 50022) mount
- High input/output insulation

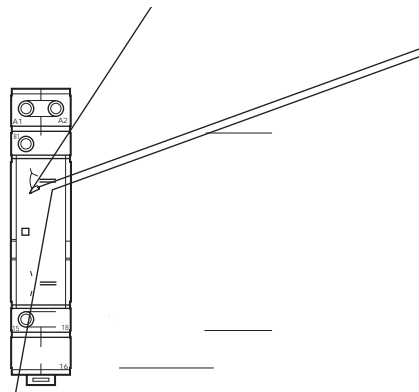
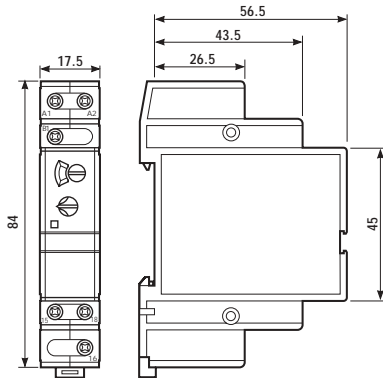

## 80.41

## 80.91



- Mono-voltage
- Mono-function

- Multi-voltage
- Mono-function

**BE:** Signal OFF delay

**LI:** Asymmetrical recycler (ON starting)  
**LE:** Signal asymmetrical recycler (ON starting)

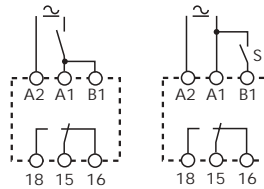
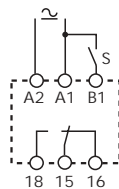

wiring diagram (with signal START)

Contact specifications			
Contact configuration		1 CO	1 CO
Rated current/Maximum peak current	A	16/30	16/30
Rated voltage/Maximum switching voltage V AC		250/400	250/400
Rated load in AC1	VA	4000	4000
Rated load in AC15 (230 VAC)	VA	750	750
Single phase motor rating (230 VAC)	kW	0.55	0.55
Breaking capacity in DC1:	30/110/220V A	16/0.3/0.12	16/0.3/0.12
Minimum switching load	mW(V/mA)	500 (10/5)	500 (10/5)
Standard contact material		AgCdO	AgCdO
Supply specifications			
Nominal voltage	V AC(50/60Hz)	24 · 230...240	12...240
	V DC	24	12...240 (non polarized)
Rated power AC/DC	VA (50Hz)/W	< 1.8/ < 0.6	< 1.8/ < 1.4
Operating range	AC	(0.85...1.1)U <sub>N</sub>	10.2...265 V
	DC	(0.85...1.1)U <sub>N</sub>	10.2...265 V
Technical data			
Specified time range		(0.1...2) s, (1...20) s, (0.1...2) min, (1...20) min, (0.1...2) h, (1...20) h	
Repeatability	%	± 1	± 1
Recovery time	ms	≤ 50	≤ 50
Minimum control impulse	ms	50	50
Setting accuracy-full range	%	± 5	± 5
Electrical life at rated load in AC1	cycles	100·10 <sup>3</sup>	100·10 <sup>3</sup>
Ambient temperature range	°C	-10...+50	-10...+50
Protection category		IP 20	IP 20
<b>Approvals:</b> (according to type)		<b>CE</b>	

## ORDERING INFORMATION

Example: a 80 series, modular timers, 1 CO, 16 A, supply rated at 12 ... 240 V AC/DC.

**8 0 . 0 1 . 0 . 2 4 0 . 0 0 0 0**

**Series**

**Type**

0 = Multi-function (AI, DI, SW, BE, CE, DE)

1 = ON delay (AI)

2 = ON pulse (DI)

4 = Signal OFF delay (BE)

9 = Asymmetrical recycler ON starting (LI, LE)

**No. of poles**

1 = 1 CO

**Supply voltage**

024 = 24 V AC/DC

240 = 230...240 V AC (80.11, 80.21, 80.41)

240 = 12 ... 240 V AC/DC (80.01, 80.91)

**Supply version**

0 = AC (50/60 Hz)/DC (80.01, 80.91)

8 = AC (50/60 Hz) (80.11, 80.21, 80.41)

## TECHNICAL DATA

### EMC SPECIFICATIONS

TYPE OF TEST		REFERENCE STANDARD	
ELECTROSTATIC DISCHARGE	- contact discharge	EN 61000-4-2	4 kV
	- air discharge	EN 61000-4-2	8 kV
RADIO-FREQUENCY ELECTROMAGNETIC FIELD (80 ÷ 1000 MHz)		EN 61000-4-3	10 V/m
FAST TRANSIENTS (burst) (5-50 ns, 5 kHz) on Supply terminals		EN 61000-4-4	4kV
SURGES (1.2/50 µs) on Supply terminals	- common mode	EN 61000-4-5	4 kV
	- differential mode	EN 61000-4-5	4 kV
	on start terminal (B1) - common mode	EN 61000-4-5	4 kV
	- differential mode	EN 61000-4-5	4 kV
RADIO-FREQUENCY COMMON MODE (0.15 ÷ 80 MHz) on Supply terminals		EN 61000-4-6	10 V
RADIATED AND CONDUCTED EMISSION		EN 55022	class B

### INSULATION

DIELECTRIC STRENGTH	- between input and output circuit	V AC	4,000
	- between open contacts	V AC	1,000
INSULATION (1.2/50 µs) between input and output		kV	6

### OTHER DATA

CURRENT ABSORPTION on signal control (B1)		< 1 mA	
POWER LOST TO THE ENVIRONMENT	- without contact current	W	1.3
	- with rated current	W	3.2
MAX WIRE SIZE		solid cable	stranded cable
		mm <sup>2</sup>	1x6 / 2x4
		AWG	1x10 / 2x12
SCREW TORQUE			1x12 / 2x14
		Nm	0.8

FUNCTIONS

	LED Red	Supply voltage	NO output contact	Contacts	
				Open	Closed
U = Supply voltage		OFF	Open	15 - 18	15 - 16
S = Signal switch		ON	Open	15 - 18	15 - 16
		ON	Open (Timing in Progress)	15 - 18	15 - 16
		ON	Closed	15 - 16	15 - 18

Without signal Start = Start via contact in supply line (A1).  
 With signal Start = Start via contact into control terminal (B1).

Wiring diagram

Without signal START

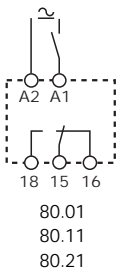

<b>Type</b>		<b>(AI) ON delay.</b> Apply power to timer. Output contacts transfer after preset time has elapsed. Reset occurs when power is removed.
<b>80.01</b> <b>80.11</b>		<b>(DI) ON pulse.</b> Apply power to timer. Output contacts transfer immediately. After the preset time has elapsed, contacts reset.
<b>80.01</b>		<b>(SW) Symmetrical recycler: ON start.</b> Apply power to timer. Output contacts transfer immediately and cycle between ON and OFF for as long as power is applied. The ratio is 1:1 (time on = time off).

With signal START

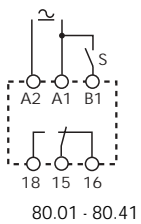

<b>80.01</b> <b>80.41</b>		<b>(BE) Signal OFF delay.</b> Power is permanently applied to the timer. The output contacts transfer immediately on closure of the Signal Switch (S). Opening the Signal Switch initiates the preset delay, after which time the output contacts reset.
<b>80.01</b>		<b>(CE) Signal ON and OFF delay.</b> Power is permanently applied to the timer. Closing the Signal Switch (S) initiates the preset delay, after which time the output contacts transfer. Opening the Signal switch initiates the same preset delay, after which time the output contacts reset.
<b>80.01</b>		<b>(DE) Signal ON pulse.</b> Power is permanently applied to the timer. On momentary or maintained closure of Signal Switch (S), the output contacts transfer, and remain so for the duration of the preset delay, after which they reset.

Without signal START

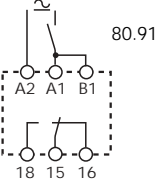

<b>80.91</b>		<b>(LI) Asymmetrical recycler (ON starting).</b> Apply power to timer. Output contacts transfer immediately and cycle between ON and OFF for as long as power is applied. The ON and OFF times are independently adjustable.
<b>80.91</b>		<b>(LE) Signal asymmetrical recycler (ON starting)</b> Power is permanently applied to the timer. Closing Signal Switch (S) causes the output contacts to transfer immediately and cycle between ON and OFF, until opened.

With signal START

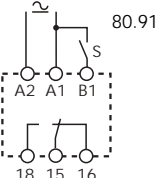

NOTE: time scales and functions must be set before energising the timer.



\* - With DC supply, positive polarity has to be connected to B1 terminal (according to EN 60204-1).  
 - A voltage other than the supply voltage can be applied to the command Start (B1), example:  
 A1-A2 = 230VAC  
 B1-A2 = 12VAC

## 81.01

- Multi-voltage multi-function timer
- One module (17.5 mm) wide housing
- Seven functions (4 with supply start and 3 with signal start)
- Six time scales, from 0.1s to 10h
- 35 mm rail (EN 50022) mount

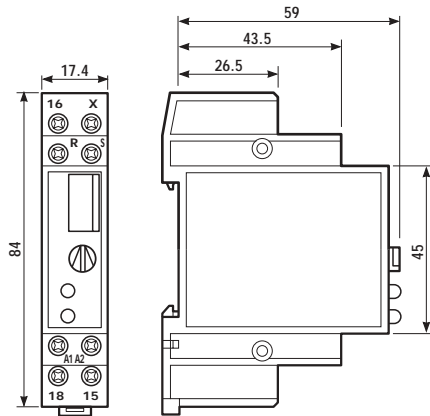

- Multi-voltage (DC non polarized)
- Multi-function
- 35 mm rail mounting

- AI:** ON delay                      **BE:** Signal OFF delay  
**DI:** ON pulse                      **DE:** Signal ON pulse  
**SW:** Symmetrical recycler:      **EE:** Signal OFF pulse  
     ON start  
**SP:** Symmetrical recycler:  
     OFF start

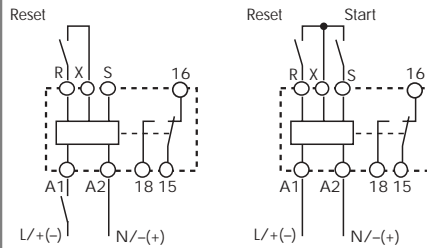

wiring diagram  
(without signal START)

wiring diagram  
(with signal START)

### Contact specifications

Contact configuration		1 CO
Rated current/Maximum peak current	A	16/30
Rated voltage/Maximum switching voltage	V AC	250/400
Rated load in AC1	VA	4,000
Rated load in AC15 (230 VAC)	VA	750
Single phase motor rating (230 VAC)	kW	0.55
Breaking capacity in DC1:	30/110/220V A	16/0.3/0.12
Minimum switching load	mW(V/mA)	500 (10/5)
Standard contact material		AgCdO

### Supply specifications

Nominal voltage	V AC(50/60Hz)	12...230
	V DC	12...230 (non polarized)
Rated power AC/DC	VA (50Hz)/W	< 2/<2
Operating range	AC	10.8...250
	DC	10.8...250

### Technical data

Specified time range		(0,1...1)s,(1...10)s,(10...60)s,(1...10)min,(10...60)min,(1...10)h
Repeatability	%	± 1
Recovery time	ms	≤ 50
Minimum control impulse	ms	50
Setting accuracy-full range	%	± 5
Electrical life at rated load in AC1	cycles	100·10 <sup>3</sup>
Ambient temperature range	°C	-10...+50
Protection category		IP 20

Approvals: (according to type)



## ORDERING INFORMATION

Example: a 81 series multi-voltage timer with 1 CO contact, 16 A for 12 ... 230 V AC/DC supply.

8

1

.

0

1

.

0

.

2

3

0

.

0

0

0

0

**Series** —————

**Type** —————  
0 = Multi-voltage

**No. of poles** —————  
1 = 1 pole

**Supply voltage**  
230 = 12 ... 230 V AC/DC

**Supply version**  
0 = AC (50/60 Hz)/DC

## TECHNICAL DATA

### EMC SPECIFICATIONS

TYPE OF TEST	REFERENCE STANDARD	
ELECTROSTATIC DISCHARGE	- contact discharge	EN 61000-4-2
	- air discharge	EN 61000-4-2
RADIO-FREQUENCY ELECTROMAGNETIC FIELD (80 ÷ 1000 MHz)	EN 61000-4-3	10 V/m
FAST TRANSIENTS (burst) (5-50 ns, 5 kHz) on Supply terminals	EN 61000-4-4	4 kV
SURGES (1.2/50 µs) on Supply terminals	- common mode	EN 61000-4-5
	- differential mode	EN 61000-4-5
RADIO-FREQUENCY COMMON MODE (0.15 ÷ 80 MHz) on Supply terminals	EN 61000-4-6	10 V
RADIATED AND CONDUCTED EMISSION	EN 55022	class B

### OTHER DATA

CURRENT ABSORPTION on signal control	< 1 mA (S-X)	< 1 mA (R-X)			
POWER LOST TO THE ENVIRONMENT					
- without contact current	W	1.3			
- with rated current	W	3.2			
	<b>LOWER TERMINAL</b>	<b>UPPER TERMINAL</b>			
MAX WIRE SIZE	solid cable	stranded cable	solid cable	stranded cable	
	mm <sup>2</sup>	1x6 / 2x4	1x4 / 2x2.5	1x4 / 2x2.5	1x2.5 / 2x2.5
	AWG	1x10 / 2x12	1x12 / 2x14	1x12 / 2x14	1x14 / 2x14
SCREW TORQUE	Nm	0.8	0.8		

## TIME SCALES

**(0.1...1) s**

**(1...10) s**

**(10...60) s**

**(1...10) min**

**(10...60) min**

**(1...10) h**

NOTE: time scales and functions must be set before energising the timer.

## FUNCTIONS

	LED		Supply voltage	NO output contact	Contacts	
	Green	Red			Open	Closed
<b>U</b> = Supply voltage			OFF	Open	15 - 18	15 - 16
<b>S</b> = Signal switch			ON	Open	15 - 18	15 - 16
<b>C</b> = Output contact			ON	Closed	15 - 16	15 - 18

Without signal Start= Start via contact in supply line (A1).

With signal Start = Start via contact into control terminal (S-X).

### Wiring diagram

Without signal START

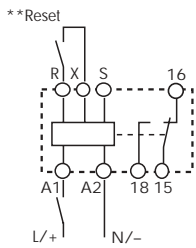

\*\*Reset facility is optional

**1** U

**2** c

**3**

**(AI) ON delay.**  
Apply power to timer. Output contacts transfer after preset time has elapsed. Reset occurs when power is removed.

**1** U

**2** c

**3**

**(DI) ON pulse.**  
Apply power to timer. Output contacts transfer immediately. After the preset time has elapsed, contacts reset.

**1** U

**2** c

**3**

**(SW) Symmetrical recycler: ON start.**  
Apply power to timer. Output contacts transfer immediately and cycle between ON and OFF for as long as power is applied. The ratio is 1:1 (time on = time off).

**1** U

**2** c

**3**

**(SP) Symmetrical recycler: OFF start.**  
Apply power to timer. Output contacts transfer after time T has elapsed and cycle between OFF and ON for as long as power is applied. The ratio is 1:1 (time on = time off).

With signal START

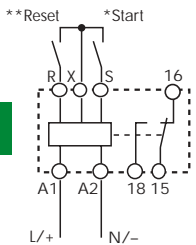

\* Terminals R, X & S must not be directly connected to the timer supply voltage, but they should be considered to be a supply voltage potential for the purposes of insulation.

\*\*Reset facility is optional

**1** U

**2** S

**3** c

**(BE) Signal OFF delay.**  
Power is permanently applied to the timer. The output contacts transfer immediately on closure of the Signal Switch (S). Opening the Signal Switch initiates the preset delay, after which time the output contacts reset.

**1** U

**2** S

**3** c

**(DE) Signal ON pulse.**  
Power is permanently applied to the timer. On momentary or maintained closure of Signal Switch (S), the output contacts transfer, and remain so for the duration of the preset delay, after which they reset.

**1** U

**2** S

**3** c

**(EE) Signal OFF pulse.**  
Power is permanently applied to the timer. On opening of the Signal Switch (S) the output contacts transfer, and remain so for the duration of the preset delay, after which they reset.

### RESET Function (R)

In each and every function and time scale, the timer is immediately released when the reset switch is depressed.

**1** U

**2** R

**3** c

On depressing the Signal Reset Switch the timer is immediately released. Releasing the Signal Reset Switch reactivates the function. Example: ON delay function.

**1** U

**2** S

**3** R

Depressing the Signal Reset Switch terminates the interval time. To re-start, it is necessary to depress the Signal Switch again. Example: ON pulse function.



- Mono or multi-function timers
- One module (17.5 mm) wide
- Five functions
- Six time scales, from 0.05s to 10h
- 35 mm rail (EN 50022) mount

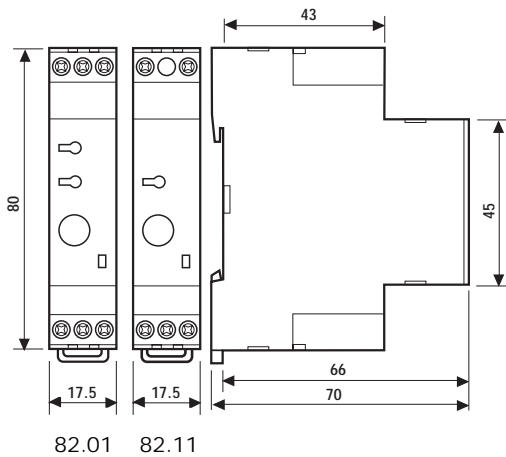

## 82.01

## 82.11

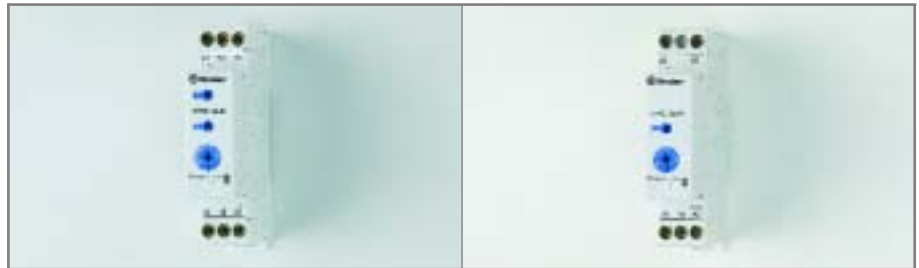

- Multi-function
- Multi-voltage
- 35 mm rail mounting

- Mono-function
- Multi-voltage
- 35 mm rail mounting

**AI:** ON delay  
**DI:** ON pulse  
**SW:** Symmetrical recycler:  
 ON start

**BE:** Signal OFF delay

**AI:** ON delay

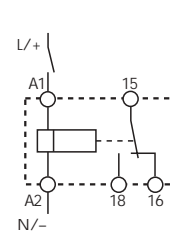
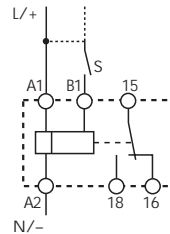
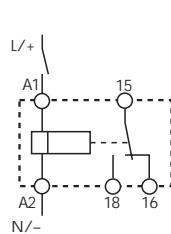

wiring diagram  
(without signal START)

wiring diagram  
(with signal START)

wiring diagram  
(without signal START)

Contact specifications		82.01	82.11
Contact configuration		1 CO	1 CO
Rated current/Maximum peak current	A	5/20	5/20
Rated voltage/Maximum switching voltage V AC		250/400	250/400
Rated load in AC1	VA	1,250	1,250
Rated load in AC15 (230 VAC)	VA	250	250
Single phase motor rating (230 VAC)	kW	0.125	0.125
Breaking capacity in DC1:	30/110/220V A	5/0.3/0.12	5/0.3/0.12
Minimum switching load	mW(V/mA)	300 (10/5)	300 (10/5)
Standard contact material		AgCdO	AgCdO
Supply specifications		82.01	82.11
Nominal voltage	V AC(50/60Hz)	24...240	24...240
	V DC	24...48	24...48
Rated power AC/DC	VA (50Hz)/W	5/0.5	5/0.5
Operating range	AC	(0.85...1.1)U <sub>N</sub>	(0.85...1.1)U <sub>N</sub>
	DC	(0.85...1.2)U <sub>N</sub>	(0.85...1.2)U <sub>N</sub>
Technical data		82.01	82.11
Specified time range		(0.05...1) s, (0.5...10) s, (0.05...1) min,	(0.5...10) min, (0.05...1) h, (0.5...10) h
Repeatability	%	± 1	± 1
Recovery time	ms	≤ 100	≤ 100
Minimum control impulse	ms	250	250
Setting accuracy-full range	%	± 5	± 5
Electrical life at rated load in AC1	cycles	100·10 <sup>3</sup>	100·10 <sup>3</sup>
Ambient temperature range	°C	-20...+50	-20...+50
Protection category		IP 20	IP 20
<b>Approvals:</b> (according to type)			

- Mono or multi-function timers
- One module (17.5 mm) wide
- Five functions
- Six time scales, from 0.05s to 10h
- 35 mm rail (EN 50022) mount

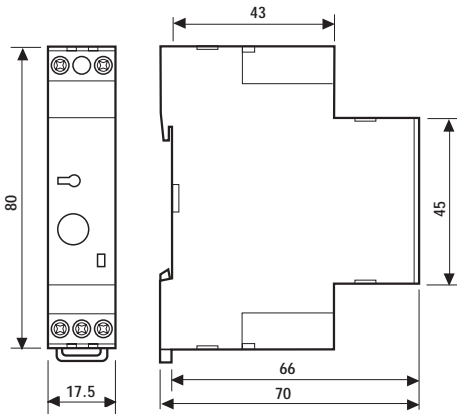

## 82.21



- Mono-function
- Multi-voltage
- 35 mm rail mounting

**DI:** ON pulse

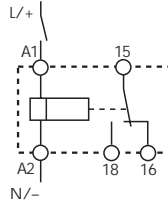

wiring diagram  
(without signal START)

## 82.31



- Mono-function
- Multi-voltage
- 35 mm rail mounting

**SW:** Symmetrical recycler: ON start

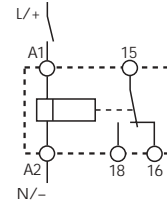

wiring diagram  
(without signal START)

Contact specifications			
Contact configuration		1 CO	1 CO
Rated current/Maximum peak current	A	5/20	5/20
Rated voltage/Maximum switching voltage	V AC	250/400	250/400
Rated load in AC1	VA	1,250	1,250
Rated load in AC15 (230 VAC)	VA	250	250
Single phase motor rating (230 VAC)	kW	0.125	0.125
Breaking capacity in DC1:	30/110/220V A	5/0.3/0.12	5/0.3/0.12
Minimum switching load	mW(V/mA)	300 (10/5)	300 (10/5)
Standard contact material		AgCdO	AgCdO
Supply specifications			
Nominal voltage	V AC(50/60Hz)	24...240	24...240
	V DC	24...48	24...48
Rated power AC/DC	VA (50Hz)/W	5/0.5	5/0.5
Operating range	AC	(0.85...1.1)U <sub>N</sub>	(0.85...1.1)U <sub>N</sub>
	DC	(0.85...1.2)U <sub>N</sub>	(0.85...1.2)U <sub>N</sub>
Technical data			
Specified time range		(0.05...1) s, (0.5...10) s, (0.05...1) min,	(0.5...10) min, (0.05...1) h, (0.5...10) h
Repeatability	%	± 1	± 1
Recovery time	ms	≤ 100	≤ 100
Minimum control impulse	ms	250	250
Setting accuracy-full range	%	± 5	± 5
Electrical life at rated load in AC1	cycles	100·10 <sup>3</sup>	100·10 <sup>3</sup>
Ambient temperature range	°C	-20...+50	-20...+50
Protection category		IP 20	IP 20
<b>Approvals:</b> (according to type)			

82.41

82.82



**BE:** Signal OFF delay

**SD:** Star- Delta

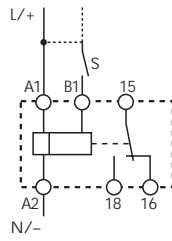

wiring diagram  
(with signal START)

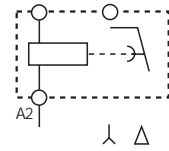

wiring diagram  
(without signal START)

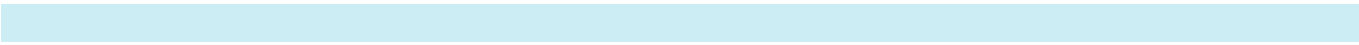

Handwritten notes area with horizontal lines.

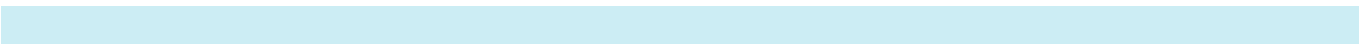

Handwritten notes area with horizontal lines.



Handwritten notes area with horizontal lines.

## ORDERING INFORMATION

Example: a 82 series, multi-function modular timer, 24 to 48 V DC and 24 to 240 V AC (50/60) Hz supply voltage.

**8 2 . 0 1 . 0 . 2 4 0 . 0 0 0 0**

**Series**

**Type**

- 0 = Multi-function (AI, DI, BE, SW)
- 1 = ON delay (AI)
- 2 = ON pulse (DI)
- 3 = Symmetrical recycler: ON start (SW)
- 4 = Signal OFF delay (BE)
- 8 = Star - delta (SD)

**Supply voltage**

240 =  $\begin{cases} 24...48 \text{ V DC} \\ 24...240 \text{ V AC} \end{cases}$

**Supply version**

0 = AC (50/60 Hz)/DC

**No. of poles**

- 1 = 1 pole for types 0, 1, 2, 3, 4
- 2 = 2 pole for star - delta

## TECHNICAL DATA

### EMC SPECIFICATIONS

TYPE OF TEST	REFERENCE STANDARD	
ELECTROSTATIC DISCHARGE	- contact discharge	EN 61000-4-2
	- air discharge	EN 61000-4-2
RADIO-FREQUENCY ELECTROMAGNETIC FIELD (80 ÷ 1000 MHz)	EN 61000-4-3	10V/m
FAST TRANSIENTS (burst) (5-50 ns, 5 kHz) on Supply terminals	EN 61000-4-4	6 kV
SURGES (1.2/50 µs) on Supply terminals	- common mode	EN 61000-4-5
	- differential mode	EN 61000-4-5
RADIO-FREQUENCY COMMON MODE (0.15 ÷ 80 MHz) on Supply terminals	EN 61000-4-6	10 V
RADIATED AND CONDUCTED EMISSION	EN 55022	class B

### OTHER DATA

CURRENT ABSORPTION on signal control (B1)	1mA		
POWER LOST TO THE ENVIRONMENT			
- without contact current	W 5		
- with rated current	W 6		
MAX WIRE SIZE	solid cable	stranded cable	
	mm <sup>2</sup>	1x4 / 2x2.5	1x4 / 2x1.5
	AWG	1x12 / 2x14	1x12 / 2x16
⊕ SCREW TORQUE	Nm	1	

## TIME SCALES

Type	Function Code	Function	s	s	s	min	min	h	h
			0.05	0.15	0.5	0.05	0.5	0.05	0.5
			1	3	10	1	10	1	10
82.01	AI	ON delay	•		•	•	•	•	•
	BE	Signal OFF delay	•		•	•	•	•	•
	DI	ON pulse	•		•	•	•	•	•
	SW	Symmetrical recycler: ON start	•		•	•	•	•	•
82.11	AI	ON delay	•		•	•	•	•	
82.21	DI	ON pulse	•		•	•	•	•	
82.31	SW	Symmetrical recycler: ON start	•		•	•	•	•	
82.41	BE	Signal OFF delay	•		•	•	•	•	
82.82	SD	Star - delta		•	•	•	•		

NOTE: time scales and functions must be set before energising the timer.

# FUNCTIONS

## Multi-function without signal START

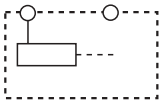

82.01  
with signal START (S)

82.01

## Mono-function without signal START

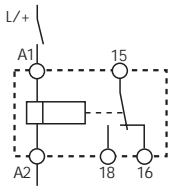

82.11  
82.21  
82.31

82.82

with signal START

82.41

Type <b>82.01</b>	<p><b>(AI) ON delay.</b> Apply power to timer. Output contacts transfer after preset time has elapsed. Reset occurs when power is removed.</p> <p><b>(DI) ON pulse.</b> Apply power to timer. Output contacts transfer immediately. After the preset time has elapsed, contacts reset.</p> <p><b>(SW) Symmetrical recycler: ON start.</b> Apply power to timer. Output contacts transfer immediately and cycle between ON and OFF for as long as power is applied. The ratio is 1:1 (time on = time off).</p>
	<p><b>(BE) Signal OFF delay.</b> Power is permanently applied to the timer. The output contacts transfer immediately on closure of the Signal Switch (S). Opening the Signal Switch initiates the preset delay, after which time the output contacts reset.</p>
<b>82.11</b>	<p><b>(AI) ON delay.</b> Apply power to timer. Output contacts transfer after preset time has elapsed. Reset occurs when power is removed.</p>
<b>82.21</b>	<p><b>(DI) ON pulse.</b> Apply power to timer. Output contacts transfer immediately. After the preset time has elapsed, contacts reset.</p>
<b>82.31</b>	<p><b>(SW) Symmetrical recycler: ON start.</b> Apply power to timer. Output contacts transfer immediately and cycle between ON and OFF for as long as power is applied. The ratio is 1:1 (time on = time off).</p>
<b>82.82</b>	<p><b>(SD) Star - delta.</b> Apply power to timer. The star contact (λ) closes immediately. After preset delay has elapsed the star contact (λ) resets. After a further fixed time of ~60 ms the delta contact (Δ) closes and remains in that position, until reset on power off.</p>
<b>82.41</b>	<p><b>(BE) Signal OFF delay.</b> Power is permanently applied to the timer. The output contacts transfer immediately on closure of the Signal Switch (S). Opening the Signal Switch initiates the preset delay, after which time the output contacts reset.</p>

- Plug-in timer relay
- 2, 3 or 4 CO contact available
- Six time scales, from 0.1s to 10h
- Sockets: see 94 series

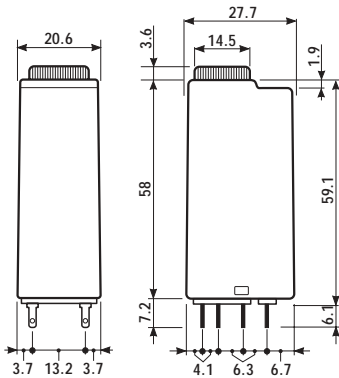

## 85.32



- 2 Pole, 10A
- AC/DC supply non polarized
- Plug-in for use with 94 series sockets

**AI:** ON delay  
**DI:** ON pulse

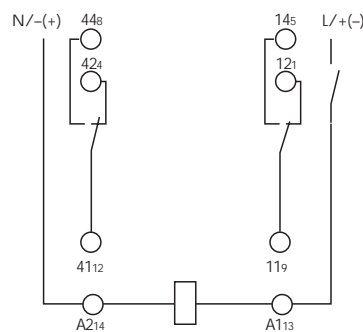

wiring diagram

## 85.33



- 3 Pole, 10A
- AC/DC supply non polarized
- Plug-in for use with 94 series sockets

**AI:** ON delay  
**DI:** ON pulse

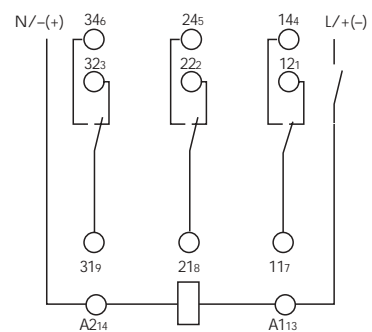

wiring diagram

### Contact specifications

Contact configuration		2 CO	3 CO
Rated current/Maximum peak current	A	10/20	10/20
Rated voltage/Maximum switching voltage	V AC	250/400	250/400
Rated load in AC1	VA	2,500	2,500
Rated load in AC15 (230 VAC)	VA	500	500
Single phase motor rating (230 VAC)	kW	0.37	0.37
Breaking capacity in DC1:	30/110/220V A	10/0.25/0.1	10/0.25/0.1
Minimum switching load	mW(V/mA)	300 (5/5)	300 (5/5)
Standard contact material		AgNi	AgNi

### Supply specifications

Nominal voltage	V AC(50/60Hz)	230...240	230...240
	V AC/DC	12 - 24 - 48 - 110...125 (non polarized)	12 - 24 - 48 - 110...125 (non polarized)
Rated power AC/DC	VA (50Hz)/W	2/2	2/2
Operating range	AC	(0.85...1.1)U <sub>N</sub>	(0.85...1.1)U <sub>N</sub>
	DC	(0.85...1.1) U <sub>N</sub>	(0.85...1.1)U <sub>N</sub>

### Technical data

Specified time range		(0.1...1) s, (1...10) s, (10...60) s, (1...10) min, (10...60) min, (1...10) h	
Repeatability	%	± 2	± 2
Recovery time	ms	≤ 20	≤ 20
Minimum control impulse	ms	—	—
Setting accuracy-full range	%	± 5	± 5
Electrical life at rated load in AC1	cycles	200·10 <sup>3</sup>	200·10 <sup>3</sup>
Ambient temperature range	°C	-20...+60	-20...+60
Protection category		IP 40	IP 40

**Approvals:** (according to type)



- Plug-in timer relay
- 2, 3 or 4 CO contact available
- Six time scales, from 0.1s to 10h
- Sockets: see 94 series

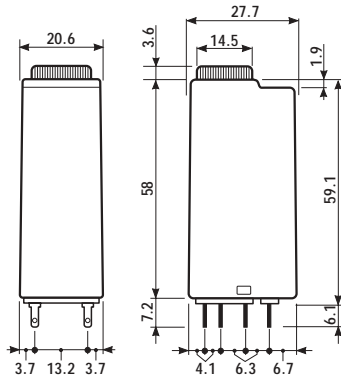

## 85.34



- 4 Pole, 5A
- AC/DC supply non polarized
- Plug-in for use with 94 series sockets

**AI:** ON delay  
**DI:** ON pulse

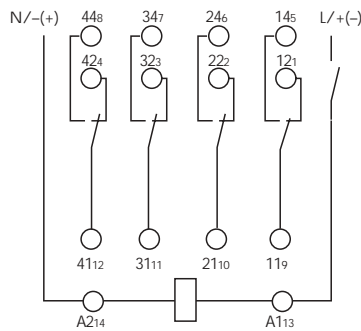

wiring diagram

## 85.52



- 2 Pole, 10A
- AC/DC supply non polarized
- Plug-in for use with 94 series sockets

**SW:** Symmetrical recycler: ON start  
**SP:** Symmetrical recycler: OFF start

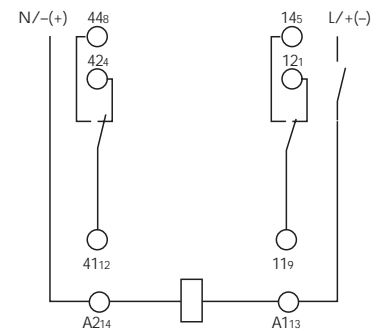

wiring diagram

Contact specifications			
Contact configuration		4 CO	2 CO
Rated current/Maximum peak current	A	5/10	10/20
Rated voltage/Maximum switching voltage	V AC	250/250	250/400
Rated load in AC1	VA	1,250	2,500
Rated load in AC15 (230 VAC)	VA	250	500
Single phase motor rating (230 VAC)	kW	0.125	0.37
Breaking capacity in DC1:	30/110/220V A	5/0.25/0.1	10/0.25/0.1
Minimum switching load	mW(V/mA)	300 (5/5)	300 (5/5)
Standard contact material		AgNi	AgNi
Supply specifications			
Nominal voltage	V AC(50/60Hz)	230...240	230...240
	V AC/DC	12 - 24 - 48 - 110...125 (non polarized)	12 - 24 - 48 - 110...125 (non polarized)
Rated power AC/DC	VA (50Hz)/W	2/2	2/2
Operating range	AC	(0.85...1.1)U <sub>N</sub>	(0.85...1.1)U <sub>N</sub>
	DC	(0.85...1.1) U <sub>N</sub>	(0.85...1.1)U <sub>N</sub>
Technical data			
Specified time range		(0.1...1) s, (1...10) s, (10...60) s, (1...10) min, (10...60) min, (1...10) h	
Repeatability	%	± 2	± 2
Recovery time	ms	≤ 20	≤ 20
Minimum control impulse	ms	—	—
Setting accuracy-full range	%	± 5	± 5
Electrical life at rated load in AC1	cycles	150·10 <sup>3</sup>	200·10 <sup>3</sup>
Ambient temperature range	°C	-20...+60	-20...+60
Protection category		IP 40	IP 40
<b>Approvals:</b> (according to type)			

- Plug-in timer relay
- 2, 3 or 4 CO contact available
- Six time scales, from 0.1s to 10h
- Sockets: see 94 series

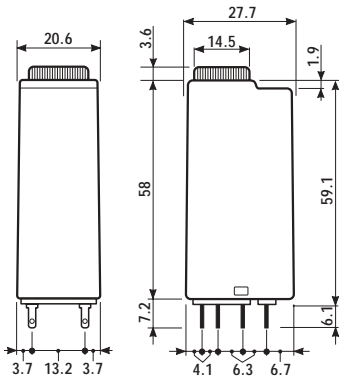

### 85.53



- 3 Pole, 10A
- AC/DC supply non polarized
- Plug-in for use with 94 series sockets

**SW:** Symmetrical recycler: ON start  
**SP:** Symmetrical recycler: OFF start

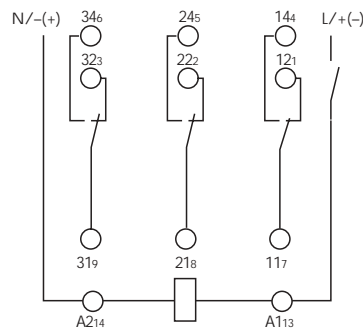

wiring diagram

### 85.54



- 4 Pole, 5A
- AC/DC supply non polarized
- Plug-in for use with 94 series sockets

**SW:** Symmetrical recycler: ON start  
**SP:** Symmetrical recycler: OFF start

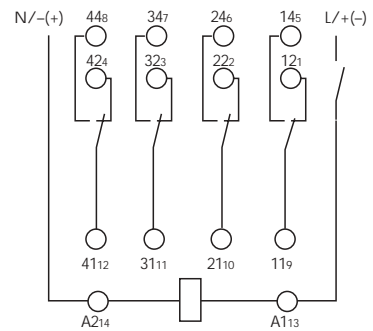

wiring diagram

Contact specifications			
Contact configuration		3 CO	4 CO
Rated current/Maximum peak current	A	10/20	5/20
Rated voltage/Maximum switching voltage	V AC	250/400	250/250
Rated load in AC1	VA	2,500	1,250
Rated load in AC15 (230 VAC)	VA	500	250
Single phase motor rating (230 VAC)	kW	0.37	0.125
Breaking capacity in DC1:	30/110/220V A	10/0.25/0.1	5/0.25/0.1
Minimum switching load	mW(V/mA)	300 (5/5)	300 (5/5)
Standard contact material		AgNi	AgNi
Supply specifications			
Nominal voltage	V AC(50/60Hz)	230...240	230...240
	V AC/DC	12 - 24 - 48 - 110...125 (non polarized)	12 - 24 - 48 - 110...125 (non polarized)
Rated power AC/DC	VA (50Hz)/W	2/2	2/2
Operating range	AC	(0.85...1.1)U <sub>N</sub>	(0.85...1.1)U <sub>N</sub>
	DC	(0.85...1.1) U <sub>N</sub>	(0.85...1.1)U <sub>N</sub>
Technical data			
Specified time range		(0.1...1) s, (1...10) s, (10...60) s, (1...10) min, (10...60) min, (1...10) h	
Repeatability	%	± 2	± 2
Recovery time	ms	≤ 20	≤ 20
Minimum control impulse	ms	—	—
Setting accuracy-full range	%	± 5	± 5
Electrical life at rated load in AC1	cycles	200·10 <sup>3</sup>	150·10 <sup>3</sup>
Ambient temperature range	°C	-20...+60	-20...+60
Protection category		IP 40	IP 40
<b>Approvals:</b> (according to type)			



## ORDERING INFORMATION

Example: 85 series timer, 4 CO, 24 V AC/DC supply voltage with AI - DI functions.

**8 5 . 3 4 . 0 . 0 2 4 . 0 0 0 0**

**Series** ————

**Type** ————  
 3 = Functions: AI (ON delay) · DI (ON pulse)  
 5 = Functions: SW · SP (Symmetrical Recycler)

**No. of poles** ————  
 2 = 2 pole · 10 A  
 3 = 3 pole · 10 A  
 4 = 4 pole · 5 A

**Supply voltage**  
 012 = 12 V AC/DC  
 024 = 24 V AC/DC  
 048 = 48 V AC/DC  
 110 = 110...125 V AC/DC  
 230 = 230...240 V AC

**Supply version**  
 0 = AC (50/60 Hz)/DC  
 8 = AC (50/60 Hz) for 230 V only

## TECHNICAL DATA

### EMC SPECIFICATIONS

TYPE OF TEST	REFERENCE STANDARD	
ELECTROSTATIC DISCHARGE	- contact discharge	EN 61000-4-2
	- air discharge	EN 61000-4-2
RADIO-FREQUENCY ELECTROMAGNETIC FIELD (80 ÷ 1000 MHz)	EN 61000-4-3	15 V/m
FAST TRANSIENTS (burst) (5-50 ns, 5 kHz) on Supply terminals	EN 61000-4-4	4 kV
SURGES (1.2/50 µs) on Supply terminals	- common mode	EN 61000-4-5
	- differential mode	EN 61000-4-5
RADIO-FREQUENCY COMMON MODE (0.15 ÷ 80 MHz) on Supply terminals	EN 61000-4-6	10 V
POWER-FREQUENCY (50 Hz)	EN 61000-4-8	30 A/m
RADIATED AND CONDUCTED EMISSION	EN 55022	class B





### OTHER DATA

POWER LOST TO THE ENVIRONMENT		2 pole	3 pole	4 pole
- without contact current	W	1.6	1.6	1.6
- with rated current	W	3.7	4.7	3.3

## TIME SCALES

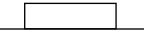
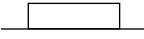
(0.1...1) s    (1...10) s    (10...60) s    (1...10) min    (10...60) min    (1...10) h

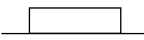
NOTE: time scales and functions must be set before energising the timer.

	Green	LED	Red	Supply voltage	NO output contact
<b>U</b> = Supply voltage				OFF	Open
<b>C</b> = Output contact				ON	Open
				ON	Closed

Types: 85.32, 85.33, 85.34

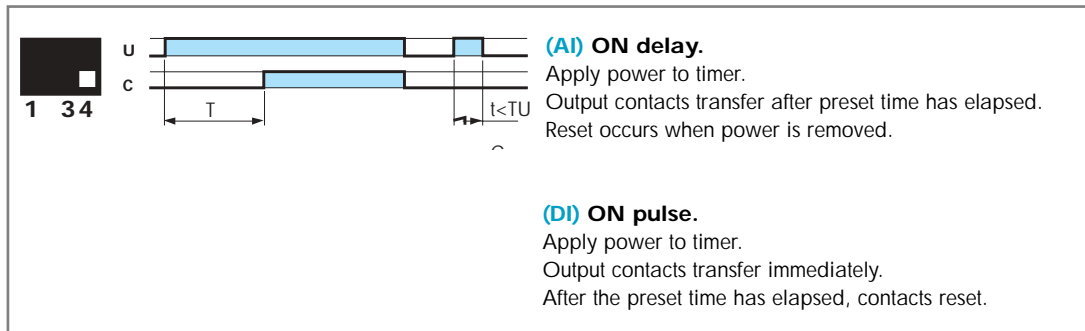

Types: 85.52, 85.53, 85.54

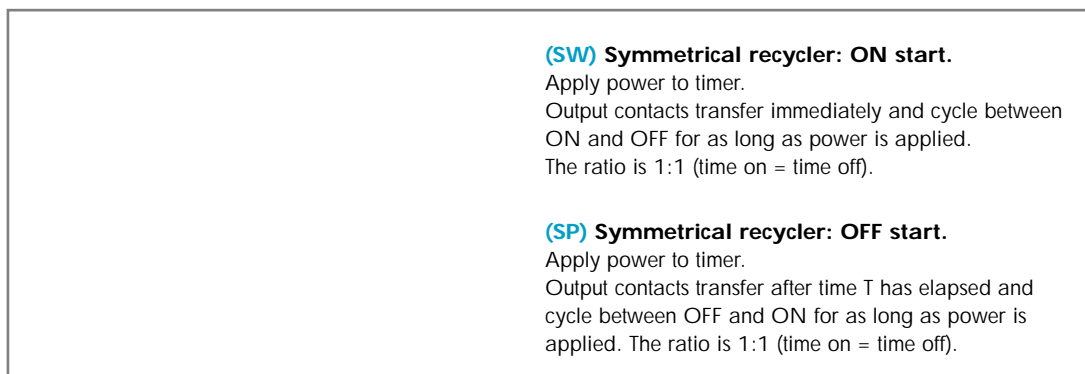



94.04

Approvals  
(according to type):



- RATED VALUES: 10 A - 250 V
- DIELECTRIC STRENGTH:  $\geq 2$  kV AC
- PROTECTION CATEGORY: IP 20
- AMBIENT TEMPERATURE:  $(-40...+70)^{\circ}\text{C}$
- TORQUE:  $0.5 \text{ Nm}$
- WIRE STRIP LENGTH: 8 mm
- MAX WIRE SIZE:

	solid wire	stranded wire
mm <sup>2</sup>	1x6 / 2x2.5	1x4 / 2x2.5
AWG	1x10 / 2x14	1x12 / 2x14

Timer type	85.32, 85.52		85.33, 85.53		85.34, 85.54	
Colour	BLUE	BLACK	BLUE	BLACK	BLUE	BLACK
Clamp terminal socket: panel or 35 mm rail (EN 50022) mount	94.02	94.02.0	94.03	94.03.0	94.04	94.04.0
Retaining clip (supplied with timer)	094.81					
6-way jumper link for 94.02, 94.03 and 94.04 sockets	094.06	094.06.0	094.06	094.06.0	094.06	094.06.0
Identification tag	094.00.4					

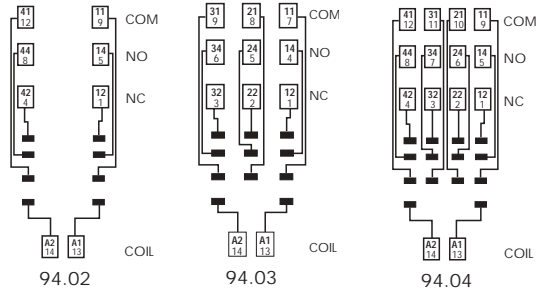
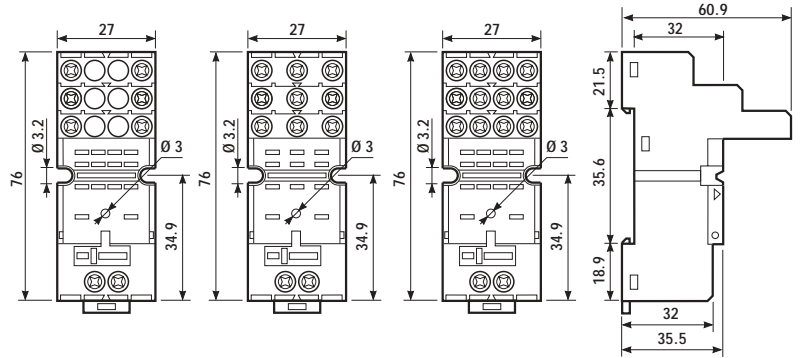

094.06

- RATED VALUES: 10 A - 250 V

6-way jumper link for 94.02, 94.03 and 94.04 sockets	094.06
--	--------

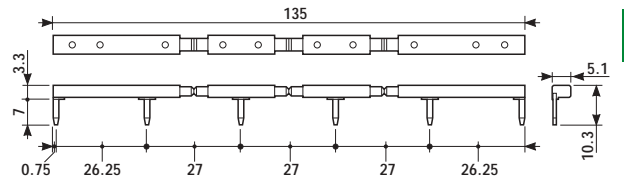

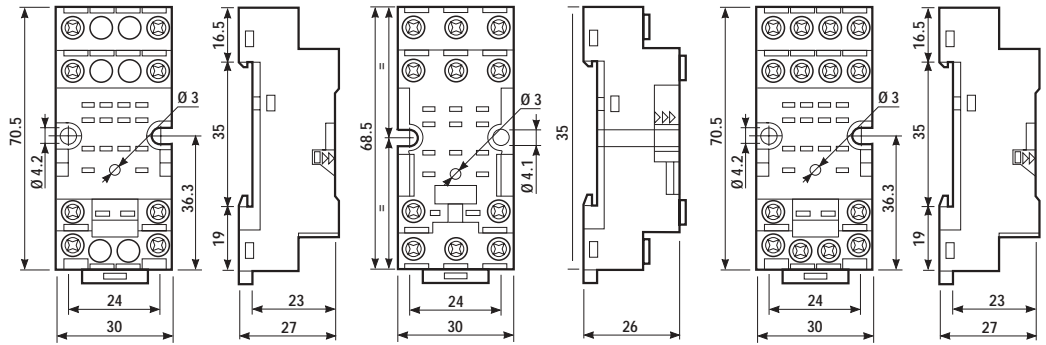

- Mono-function timer modules
- Timer module for 92, 94, 95 series sockets
- LED indicator

## 86.10

## 86.20

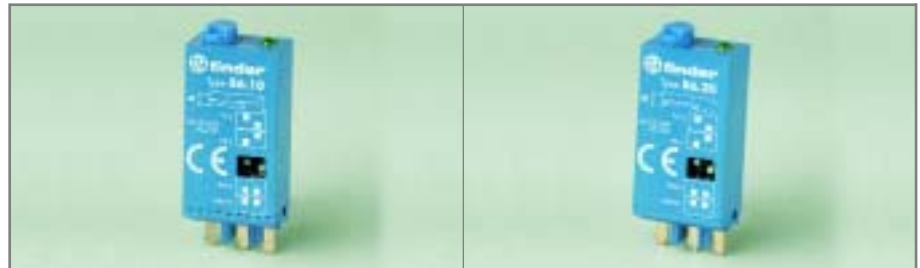

- Mono-function  
- Plug-in for use with 92.03 - 94.02 - 94.03 - 94.04 - 95.03 - 95.05 sockets

- Mono-function  
- Plug-in for use with 92.03 - 94.02 - 94.03 - 94.04 - 95.03 - 95.05 sockets

**AI:** ON delay

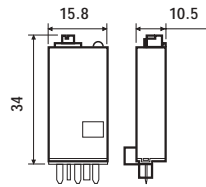
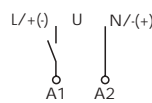

wiring diagram

**DI:** ON pulse

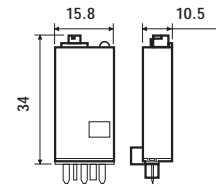
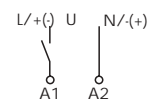

wiring diagram

Contact specifications			
Contact configuration			
Rated current/Maximum peak current	A		
Rated voltage/Maximum switching voltage	V AC		
Rated load in AC1	VA		
Rated load in AC15 (230 VAC)	VA	see 40, 44, 55 and 62 series relays	see 40, 44, 55 and 62 series relays
Single phase motor rating (230 VAC)	kW		
Breaking capacity in DC1:	30/110/220V A		
Minimum switching load	mW(V/mA)		
Standard contact material			
Supply specifications			
Nominal voltage	V AC(50/60Hz)	12...24	12...24
	V DC	12...24 (non polarized)	12...24 (non polarized)
Rated power AC/DC	mW	150	150
Operating range	AC	(0.8...1.1)U <sub>N</sub>	(0.8...1.1)U <sub>N</sub>
	DC	(0.8...1.1)U <sub>N</sub>	(0.8...1.1)U <sub>N</sub>
Technical data			
Specified time range		(1.5...15)s,(6...60)s,(0.8...8)min,(6.4...64)min	(1.5...15)s,(6...60)s,(0.8...8)min,(6.4...64)min
Repeatability	%	± 1	± 1
Recovery time	ms	≤ 150	≤ 150
Minimum control impulse	ms	—	—
Setting accuracy-full range	%	± 5	± 5
Electrical life at rated load in AC1	cycles	see 40, 44, 55 and 62 series relays	see 40, 44, 55 and 62 series relays
Ambient temperature range	°C	0...+50	0...+50
Protection category		IP 20	IP 20
<b>Approvals:</b> (according to type)			

- Multi-function timer modules
- Timer module for 90 series sockets
- LED indicator

## 86.60



- Time scale: from 15ms to 10 h
- Multi-function
- Plug-in for use with 90.72 and 90.73 sockets

- BE:** Signal OFF delay
- DE:** Signal ON pulse
- EE:** Signal OFF pulse
- FE:** Signal ON delay + OFF pulse

- AI:** ON delay
- DI:** ON pulse
- SW:** Symmetrical recycler: ON start
- SP:** Symmetrical recycler: OFF start

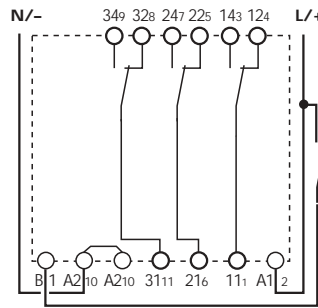
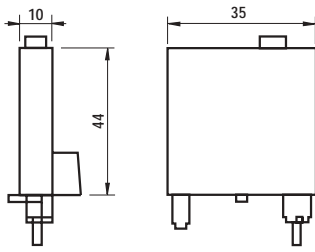

(with signal START)

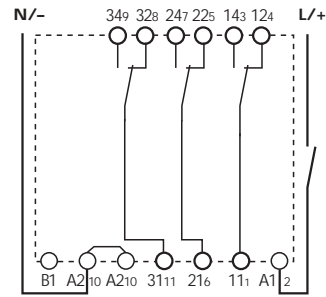

(without signal START)

wiring diagram

### Contact specifications

Contact configuration	
Rated current/Maximum peak current	A
Rated voltage/Maximum switching voltage	V AC
Rated load in AC1	VA
Rated load in AC15 (230 VAC)	VA
Single phase motor rating (230 VAC)	kW
Breaking capacity in DC1:	30/110/220V A
Minimum switching load	mW(V/mA)
Standard contact material	

see 60 series relays

### Supply specifications

Nominal voltage	V AC(50/60Hz)	12...90 - 110...240
	V DC	12...90 - 110...220
Rated current absorption AC/DC	mA	4.6/8
Operating range	AC	10.8...100 - 100...255
	DC	10.8...100 - 100...240

### Technical data

Specified time range		(15...125)ms, (0.1...1)s, (1...10)s, (0.1...1)min, (1...10)min, (0.1...1)h, (1...10)h
Repeatability	%	± 1
Recovery time	ms	≤ 120
Minimum control impulse	ms	20
Setting accuracy-full range	%	± 1
Electrical life at rated load in AC1	cycles	see 60 series relays
Ambient temperature range	°C	-20...+50
Protection category		IP 20

**Approvals:** (according to type)



## ORDERING INFORMATION

Example: a 86 series mono-function timer module with (12 to 24) V AC/DC supply voltage.

<b>8</b>	<b>6</b>	<b>.</b>	<b>1</b>	<b>0</b>	<b>.</b>	<b>0</b>	<b>.</b>	<b>0</b>	<b>2</b>	<b>4</b>	<b>.</b>	<b>0</b>	<b>0</b>	<b>0</b>	<b>0</b>
----------	----------	----------	----------	----------	----------	----------	----------	----------	----------	----------	----------	----------	----------	----------	----------

**Series** ————

**Type** ————

1 = Mono-function (AI)  
2 = Mono-function (DI)  
6 = Multi-function (AI, DI, SW, SP, BE, DE, EE, FE)

**No. of poles** ————

see 40, 41, 44, 55, 60 and 62 series relays

**Supply voltage**  
024 = 12...24 V AC/DC (86.10/20 only)  
100 = 12...90 V AC/DC (86.60 only)  
250 = { 110...220 V DC (86.60 only)  
          110...240 V AC

**Supply version**  
0 = AC (50/60 Hz)/DC

## COMBINATIONS

Number of poles	Relay type	Socket type	Timer module
1	40.31	95.03	86.10/86.20
1	40.61	95.05	86.10/86.20
2	40.52/44.52/44.62	95.05	86.10/86.20
2	55.32	94.02	86.10/86.20
2	62.32	92.03	86.10/86.20
3	55.33	94.03	86.10/86.20
3	62.33	92.03	86.10/86.20
4	55.34	94.04	86.10/86.20
2	60.12	90.72	86.60
3	60.13	90.73	86.60

## TECHNICAL DATA

### EMC SPECIFICATIONS

TYPE OF TEST	REFERENCE STANDARD	86.10/20	86.60
ELECTROSTATIC DISCHARGE	- contact discharge	EN 61000-4-2	n.a.
	- air discharge	EN 61000-4-2	4 kV
RADIO-FREQUENCY ELECTROMAGNETIC FIELD (80 ÷ 1000 MHz)	EN 61000-4-3	8 kV	8 kV
FAST TRANSIENTS (burst) (5-50 ns, 5 kHz) on Supply terminals	EN 61000-4-4	10 V/m	10 V/m
SURGES (1.2/50 µs) on Supply terminals	- common mode	EN 61000-4-5	2 kV
	- differential mode	EN 61000-4-5	2 kV
RADIO-FREQUENCY COMMON MODE (0.15 ÷ 80 MHz) on Supply terminals	EN 61000-4-6	—	1 kV
RADIATED AND CONDUCTED EMISSION	EN 55022	10 V	10 V
		class B	class B

### OTHER DATA

	86.10, 86.20	86.60
CURRENT ABSORPTION on signal control (B1)	mA	—
POWER LOST IN THE ENVIRONMENT		1
- without contact current	W	0.2
- with rated current	see 40, 44, 55, 62 series relays	0.1 (12 V) - 1 (230 V)
		see 60 series relays

## TIME SCALES

Type 86.10  
Type 86.20

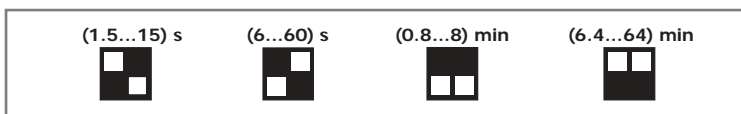

Type 86.60

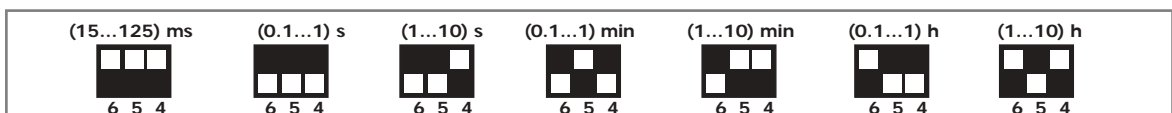

NOTE: time scales and functions must be set before energising the timer.

## FUNCTIONS

	LED		Supply voltage	NO output contact
	Green (86.60 only)	Yellow		
<b>U</b> = Supply Voltage			OFF	Open
<b>S</b> = Signal switch			ON	Open
<b>C</b> = Output Contact			ON	Closed

Without signal Start= Start via contact in supply line (A1).

With signal Start = Start via contact into control terminal (B1).

### Wiring diagram

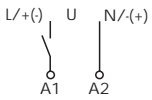

<b>Type 86.10</b> 	<b>(AI) ON delay.</b> Apply power to timer. Output contacts transfer after preset time has elapsed. Reset occurs when power is removed.
<b>Type 86.20</b> 	<b>(DI) ON pulse.</b> Apply power to timer. Output contacts transfer immediately. After the preset time has elapsed, contacts reset.

### Type 86.60

without signal START

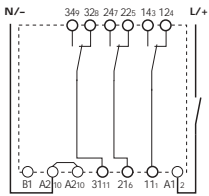

	<b>(AI) ON delay.</b> 	<b>(AI) ON delay.</b> Apply power to timer. Output contacts transfer after preset time has elapsed. Reset occurs when power is removed.
	<b>(DI) ON pulse.</b> 	<b>(DI) ON pulse.</b> Apply power to timer. Output contacts transfer immediately. After the preset time has elapsed, contacts reset.
	<b>(SW) Symmetrical recycler: ON start.</b> 	<b>(SW) Symmetrical recycler: ON start.</b> Apply power to timer. Output contacts transfer immediately and cycle between ON and OFF for as long as power is applied. The ratio is 1:1 (time on = time off).
	<b>(SP) Symmetrical recycler: OFF start.</b> 	<b>(SP) Symmetrical recycler: OFF start.</b> Apply power to timer. Output contacts transfer after time T has elapsed and cycle between OFF and ON for as long as power is applied. The ratio is 1:1 (time on = time off).

with signal START

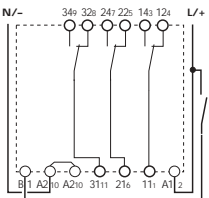

	<b>(BE) Signal OFF delay.</b> 	<b>(BE) Signal OFF delay.</b> Power is permanently applied to the timer. The output contacts transfer immediately on closure of the Signal Switch (S). Opening the Signal Switch initiates the preset delay, after which time the output contacts reset.
	<b>(DE) Signal ON pulse.</b> 	<b>(DE) Signal ON pulse.</b> Power is permanently applied to the timer. On momentary or maintained closure of Signal Switch (S), the output contacts transfer, and remain so for the duration of the preset delay, after which they reset.
	<b>(EE) Signal OFF pulse.</b> 	<b>(EE) Signal OFF pulse.</b> Power is permanently applied to the timer. On opening of the Signal Switch (S) the output contacts transfer, and remain so for the duration of the preset delay, after which they reset.
	<b>(FE) Signal ON pulse + OFF pulse.</b> 	<b>(FE) Signal ON pulse + OFF pulse.</b> Power is permanently applied to the timer. Both the opening and closing of the Signal Switch (S) initiates the transfer of the output contacts. In both instances the contacts reset after the delay period has elapsed.





95.05

Approvals  
(according to type):



- RATED VALUES: 10 A - 250 V
- INSULATION:  $\geq 6$  kV (1.2/50  $\mu$ s) between coil and contacts
- PROTECTION CATEGORY: IP 20
- AMBIENT TEMPERATURE: (-40...+70) $^{\circ}$ C
- TORQUE: 0.5 Nm
- WIRE STRIP LENGTH: 8 mm
- MAX WIRE SIZE:

	solid wire	stranded wire
mm <sup>2</sup>	1x6 / 2x2.5	1x4 / 2x2.5
AWG	1x10 / 2x14	1x12 / 2x14

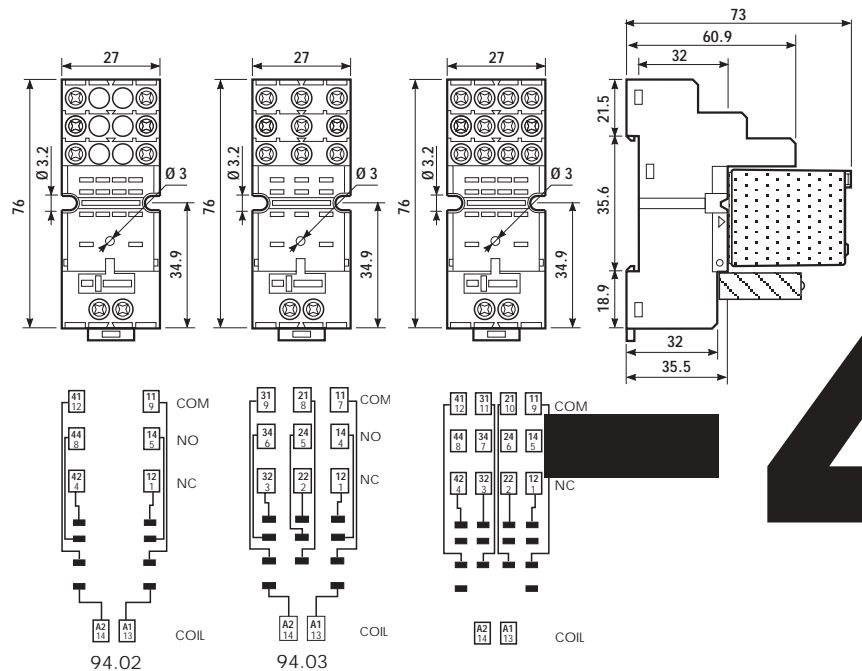
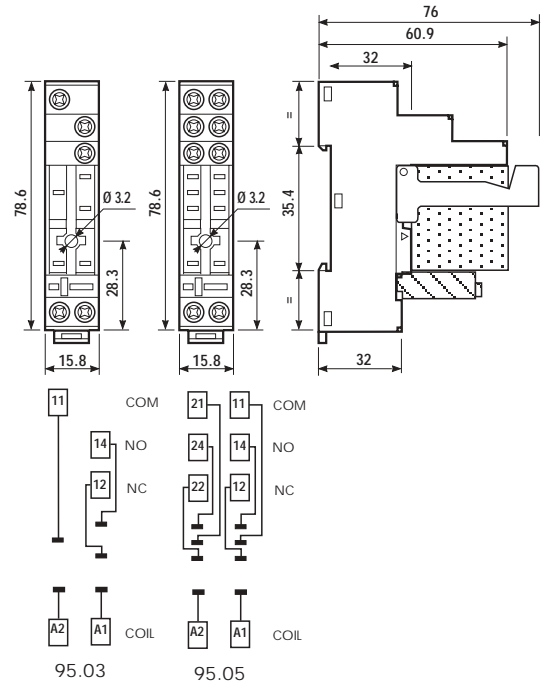



92.03

Approvals  
(according to type):



- RATED VALUES: 16 A - 250 V
- DIELECTRIC STRENGTH:  $\geq 2.5$  kV AC
- PROTECTION CATEGORY: IP 20
- AMBIENT TEMPERATURE: (-40...+70)°C
- TORQUE: 0.8 Nm
- WIRE STRIP LENGTH: 10 mm
- MAX WIRE SIZE:

	solid wire	stranded wire
mm <sup>2</sup>	1x10 / 2x4	1x6 / 2x4
AWG	1x8 / 2x12	1x10 / 2x12

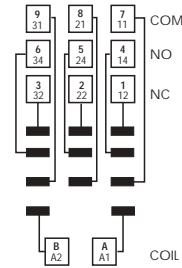
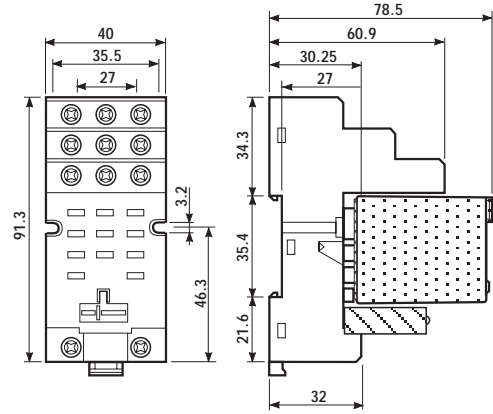

92.03



90.73



- 22.5 mm wide
- Mono-function and multi-function versions available
- Time scales from 0.05s to 60h
- "1 delayed contact + 1 instantaneous contact" and remote potentiometer version available (type 87.02)
- True OFF delay version (type 87.61/62)
- LED indicator
- 35 mm rail (EN 50022) mount

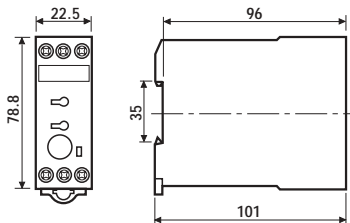

87.01

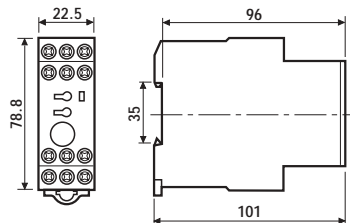

87.02

## 87.01



- Multi-function
- 1 pole
- 35 mm rail mounting

- AI:** ON delay  
**DI:** ON pulse  
**GI:** Fixed pulse delayed  
**SW:** Symmetrical recycler: ON start  
**BE:** Signal OFF delay  
**CE:** Signal ON and OFF Delay  
**DE:** Signal ON pulse  
**EE:** Signal OFF pulse

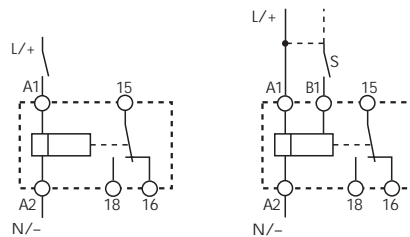

wiring diagram (without signal START)

wiring diagram (with signal START)

## 87.02



- Multi-function
- Timing can be regulated using ext. Potentiometer
- 2 timed contacts or 1 timed + 1 instantaneous contact
- 35 mm rail mounting

- AI:** ON delay  
**DI:** ON pulse  
**GI:** Fixed pulse delayed  
**SW:** Symmetrical recycler: ON start  
**BE:** Signal OFF delay  
**CE:** Signal ON and OFF Delay  
**DE:** Signal ON pulse  
**EE:** Signal OFF pulse

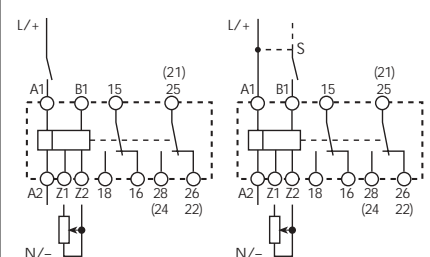

wiring diagram (without signal START)

wiring diagram (with signal START)

Contact specifications		87.01	87.02
Contact configuration		1 CO	2 CO
Rated current/Maximum peak current	A	8/30	8/30
Rated voltage/Maximum switching voltage	V AC	250/400	250/400
Rated load in AC1	VA	2,000	2,000
Rated load in AC15 (230 VAC)	VA	400	400
Single phase motor rating (230 VAC)	kW	0.185	0.185
Breaking capacity in DC1:	30/110/220V A	8/0.5/0.2	8/0.5/0.2
Minimum switching load	mW(V/mA)	300 (10/5)	300 (10/5)
Standard contact material		AgCdO	AgCdO
Supply specifications		87.01	87.02
Nominal voltage	V AC(50/60Hz)	24...240	24...240
	V DC	24...48	24...48
Rated power AC/DC	VA (50Hz)/W	5/0.5	5/0.5
Operating range	AC	(0.85...1.1)U <sub>N</sub>	(0.85...1.1)U <sub>N</sub>
	DC	(0.85...1.2) U <sub>N</sub>	(0.85...1.2)U <sub>N</sub>
Technical data		87.01	87.02
Specified time range		See page 123	See page 123
Repeatability	%	± 2	± 2
Recovery time	ms	50	50
Minimum control impulse	ms	50	50
Setting accuracy-full range	%	± 5	± 5
Electrical life at rated load in AC1	cycles	100·10 <sup>3</sup>	100·10 <sup>3</sup>
Ambient temperature range	°C	-20...+60	-20...+60
Protection category		IP 20	IP 20
Approvals: (according to type)		CE GOST	GL cUL

- 22.5 mm wide
- Mono-function and multi-function versions available
- Time scales from 0.05s to 60h
- "1 delayed contact + 1 instantaneous contact" and remote potentiometer version available (type 87.02)
- True OFF delay version (type 87.61/62)
- LED indicator
- 35 mm rail (EN 50022) mount

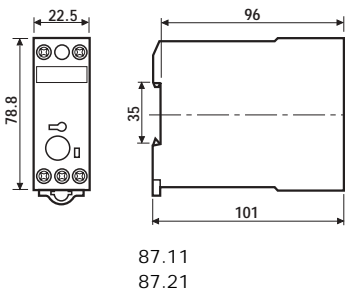

## 87.11



- Mono-function
- 35 mm rail mounting

**AI:** ON delay

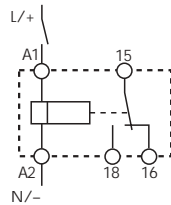

wiring diagram  
(without signal START)

## 87.21

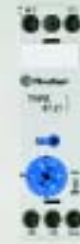

- Mono-function
- 35 mm rail mounting

**DI:** ON pulse

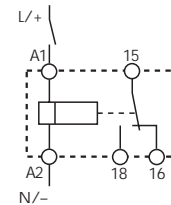

wiring diagram  
(without signal START)

Contact specifications			
Contact configuration		1 CO	1 CO
Rated current/Maximum peak current	A	8/30	8/30
Rated voltage/Maximum switching voltage	V AC	250/400	250/400
Rated load in AC1	VA	2,000	2,000
Rated load in AC15 (230 VAC)	VA	400	400
Single phase motor rating (230 VAC)	kW	0.185	0.185
Breaking capacity in DC1:	30/110/220V A	8/0.5/0.2	8/0.5/0.2
Minimum switching load	mW(V/mA)	300 (10/5)	300 (10/5)
Standard contact material		AgCdO	AgCdO
Supply specifications			
Nominal voltage	V AC(50/60Hz)	24...240	24...240
	V DC	24...48	24...48
Rated power AC/DC	VA (50Hz)/W	5/0.5	5/0.5
Operating range	AC	$(0.85...1.1)U_N$	$(0.85...1.1)U_N$
	DC	$(0.85...1.2)U_N$	$(0.85...1.2)U_N$
Technical data			
Specified time range		See page 123	See page 123
Repeatability	%	$\pm 0.2$	$\pm 0.2$
Recovery time	ms	50	50
Minimum control impulse	ms	—	—
Setting accuracy-full range	%	$\pm 5$	$\pm 5$
Electrical life at rated load in AC1	cycles	$100 \cdot 10^3$	$100 \cdot 10^3$
Ambient temperature range	°C	-20...+60	-20...+60
Protection category		IP 20	IP 20
<b>Approvals:</b> (according to type)		GOST	

- 22.5 mm wide
- Mono-function and multi-function versions available
- Time scales from 0.05s to 60h
- "1 delayed contact + 1 instantaneous contact" and remote potentiometer version available (type 87.02)
- True OFF delay version (type 87.61/62)
- LED indicator
- 35 mm rail (EN 50022) mount

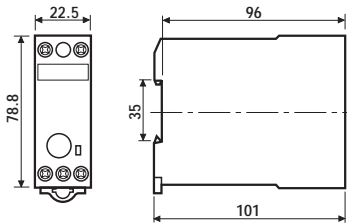

87.31

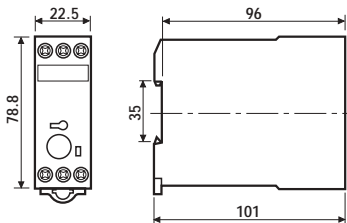

87.41

## 87.31



- Mono-function
- 35 mm rail mounting

**SW:** Symmetrical recycler: ON start

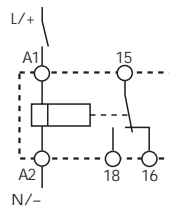

wiring diagram  
(without signal START)

## 87.41



- Mono-function
- 35 mm rail mounting

**BE:** Signal OFF delay

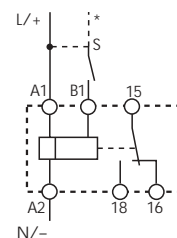

wiring diagram  
(with signal START)

Contact specifications			
Contact configuration		1 CO	1 CO
Rated current/Maximum peak current	A	8/30	8/30
Rated voltage/Maximum switching voltage	V AC	250/400	250/400
Rated load in AC1	VA	2,000	2,000
Rated load in AC15 (230 VAC)	VA	400	400
Single phase motor rating (230 VAC)	kW	0.185	0.185
Breaking capacity in DC1:	30/110/220V A	8/0.5/0.2	8/0.5/0.2
Minimum switching load	mW(V/mA)	300 (10/5)	300 (10/5)
Standard contact material		AgCdO	AgCdO
Supply specifications			
Nominal voltage	V AC(50/60Hz)	24...240	24...240
	V DC	24...48	24...48
Rated power AC/DC	VA (50Hz)/W	5/0.5	5/0.5
Operating range	AC	(0.85...1.1)U <sub>N</sub>	(0.85...1.1)U <sub>N</sub>
	DC	(0.85...1.2) U <sub>N</sub>	(0.85...1.2)U <sub>N</sub>
Technical data			
Specified time range		See page 123	See page 123
Repeatability	%	± 0.2	± 0.2
Recovery time	ms	50	50
Minimum control impulse	ms	—	50
Setting accuracy-full range	%	± 5	± 5
Electrical life at rated load in AC1	cycles	100·10 <sup>3</sup>	100·10 <sup>3</sup>
Ambient temperature range	°C	-20...+60	-20...+60
Protection category		IP 20	IP 20
<b>Approvals:</b> (according to type)		CE GOST	GL UL

- 22.5 mm wide
- Mono-function and multi-function versions available
- Time scales from 0.05s to 60h
- "1 delayed contact + 1 instantaneous contact" and remote potentiometer version available (type 87.02)
- True OFF delay version (type 87.61/62)
- LED indicator
- 35 mm rail (EN 50022) mount

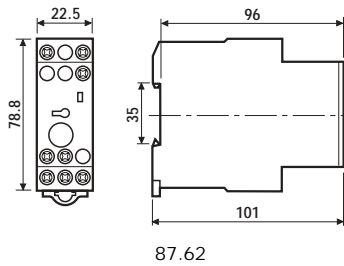
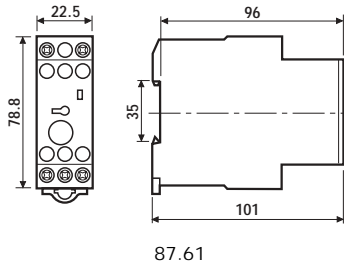

### 87.61

### 87.62



- 1 pole
- Mono-function
- 35 mm rail mounting

- 2 pole
- Mono-function
- 35 mm rail mounting

**BI:** True OFF delay

**BI:** True OFF delay

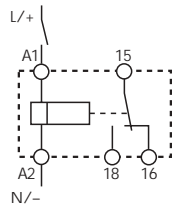

wiring diagram  
(without signal START)

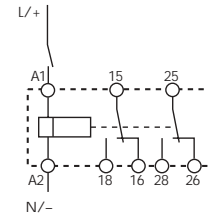

wiring diagram  
(without signal START)

Contact specifications			
Contact configuration		1 CO	2 CO
Rated current/Maximum peak current	A	5/10	5/10
Rated voltage/Maximum switching voltage	V AC	250/400	250/400
Rated load in AC1	VA	1,250	1,250
Rated load in AC15 (230 VAC)	VA	250	250
Single phase motor rating (230 VAC)	kW	0.125	0.125
Breaking capacity in DC1:	30/110/220V A	5/0.5/0.2	5/0.5/0.2
Minimum switching load	mW(V/mA)	300 (10/5)	300 (10/5)
Standard contact material		AgCdO	AgCdO
Supply specifications			
Nominal voltage	V AC(50/60Hz)	24...240	24...240
	V DC	24...240	24...240
Rated power AC/DC	VA (50Hz)/W	1.5/1.5	1.5/1.5
Operating range	AC	(0.85...1.1)U <sub>N</sub>	(0.85...1.1)U <sub>N</sub>
	DC	(0.85...1.2) U <sub>N</sub>	(0.85...1.2)U <sub>N</sub>
Technical data			
Specified time range		See page 123	See page 123
Repeatability	%	± 1	± 1
Recovery time	ms	50	50
Minimum control impulse	ms	300 ms (A1 - A2)	300 ms (A1 - A2)
Setting accuracy-full range	%	± 5	± 5
Electrical life at rated load in AC1	cycles	100·10 <sup>3</sup>	100·10 <sup>3</sup>
Ambient temperature range	°C	-20...+60	-20...+60
Protection category		IP 20	IP 20

**Approvals:** (according to type)



- 22.5 mm wide
- Mono-function and multi-function versions available
- Time scales from 0.05s to 60h
- "1 delayed contact + 1 instantaneous contact" and remote potentiometer version available (type 87.02)
- True OFF delay version (type 87.61/62)
- LED indicator
- 35 mm rail (EN 50022) mount

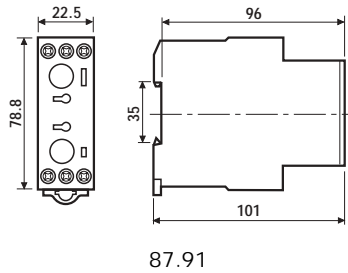
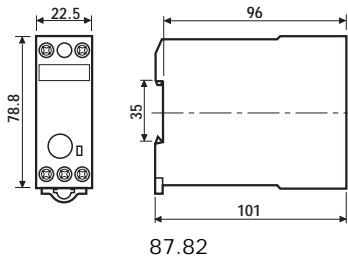

- 2 pole  
 - Mono-function: Star - delta  
 - 35 mm rail mounting

- Multi-function  
 - 35 mm rail mounting

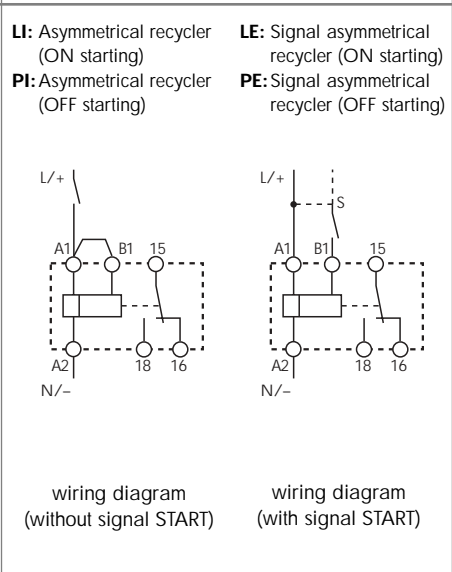
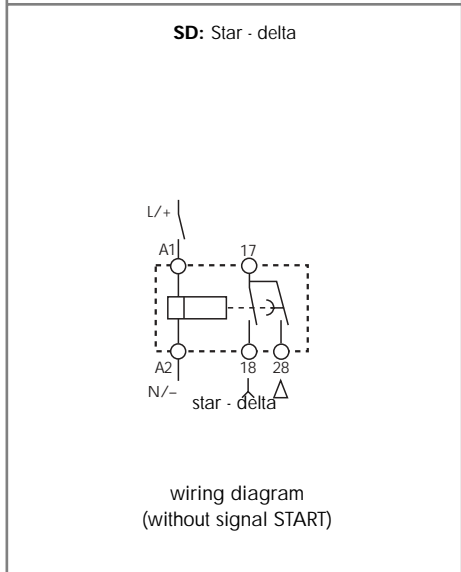

Contact specifications			
Contact configuration		2 NO	1 CO
Rated current/Maximum peak current	A	8/30	8/30
Rated voltage/Maximum switching voltage	V AC	250/400	250/400
Rated load in AC1	VA	2,000	2,000
Rated load in AC15 (230 VAC)	VA	400	400
Single phase motor rating (230 VAC)	kW	0.185	0.185
Breaking capacity in DC1:	30/110/220V A	8/0.5/0.2	8/0.5/0.2
Minimum switching load	mW(V/mA)	300 (10/5)	300 (10/5)
Supply specifications			
Nominal voltage	V AC(50/60Hz)	24...240	24...240
	V DC	24...48	24...48
Rated power AC/DC	VA (50Hz)/W	5/0.5	5/0.5
Operating range	AC	(0.85...1.1)U <sub>N</sub>	(0.85...1.1)U <sub>N</sub>
	DC	(0.85...1.2) U <sub>N</sub>	(0.85...1.2)U <sub>N</sub>
Technical data			
Specified time range		See page 123	See page 123
Repeatability	%	± 0.2	± 0.2
Recovery time	ms	50	50
Minimum control impulse	ms	—	50
Setting accuracy-full range	%	± 5	± 5
Electrical life at rated load in AC1	cycles	100-10 <sup>3</sup>	100-10 <sup>3</sup>
Ambient temperature range	°C	-20...+60	-20...+60
Protection category		IP 20	IP 20
<b>Approvals:</b> (according to type)			

## ORDERING INFORMATION

Example: 87 series 8 A multi-function timer, 1 CO contact, with (24...240) V AC (50/60) Hz and (24...48) V DC supply.

**8 7 . 0 1 . 0 . 2 4 0 . 0 0 0 0**

**Series**

**Type**

- 0 = Multi-function (AI, BE, CE, DI, DE, EE, GI, SW, ON, OFF)
- 1 = ON delay (AI)
- 2 = ON pulse (DI)
- 3 = Symmetrical recycler: ON start (SW)
- 4 = Signal OFF delay (BE)
- 6 = True OFF delay (power OFF) (BI)
- 8 = Star - delta (SD)
- 9 = Asymmetrical recycler (LI, LE, PI, PE)

**Supply voltage**

- 240 = { 24...48 V DC
- 24...240 V AC
- 240 = 24...240 V AC/DC for 87.61 and 87.62

**Supply version**

- 0 = AC (50/60 Hz)/DC

**No. of poles**

- 1 = 1 pole
- 2 = 2 pole for 87.02/62
- 2 = 2 pole for 87.82

## TECHNICAL DATA

### EMC SPECIFICATIONS

TYPE OF TEST		REFERENCE STANDARD	
ELECTROSTATIC DISCHARGE	- contact discharge	EN 61000-4-2	8 kV
	- air discharge	EN 61000-4-2	8 kV
RADIO-FREQUENCY ELECTROMAGNETIC FIELD (80 ÷ 1000 MHz)		EN 61000-4-3	10 V/m
FAST TRANSIENTS (burst) (5-50 ns, 5 kHz) on Supply terminals		EN 61000-4-4	6 kV
SURGES (1.2/50 µs) on Supply terminals	- common mode	EN 61000-4-5	4 kV
	- differential mode	EN 61000-4-5	—
RADIO-FREQUENCY COMMON MODE (0.15 ÷ 80 MHz) on Supply terminals		EN 61000-4-6	10 V
RADIATED AND CONDUCTED EMISSION		EN 55022	class B

### OTHER DATA

SIGNAL CONTROL (B1)	- current absorption	1 mA		
	- max cable length (capacity of ≤ 10 nF / 100 m)	≤ 250 m		
POWER LOST TO THE ENVIRONMENT		<b>87.01/02/11/21/31/41/91</b>	<b>87.61/62</b>	<b>87.82</b>
- without contact current	W	5	1.5	8
- with rated current	W	15	7	18
MAX WIRE SIZE		solid cable		stranded cable
	mm <sup>2</sup>	1x4 / 2x2.5		1x4 / 2x1.5
	AWG	1x12 / 2x14		1x12 / 2x16
SCREW TORQUE	Nm	1.2		



## TIME SCALES

NOTE: time scales and functions must be set before energising the timer.

Type	Function Code	Function	s	s	s	min	min	min	h	h	h	h
			0.05	0.15	0.5	0.05	0.15	0.5	0.05	0.15	0.5	3
			1	3	10	1	3	10	1	3	10	60
87.01/ 87.02	AI	ON delay	•	•	•	•	•	•	•	•	•	•
	BE	Signal OFF delay	•	•	•	•	•	•	•	•	•	•
	CE	Signal ON and OFF delay	•	•	•	•	•	•	•	•	•	•
	DI	ON pulse	•	•	•	•	•	•	•	•	•	•
	DE	Signal ON pulse	•	•	•	•	•	•	•	•	•	•
	EE	Signal OFF pulse	•	•	•	•	•	•	•	•	•	•
	GI	Fixed pulse (0,5s) delayed	•	•	•	•	•	•	•	•	•	•
	SW	Symmetrical recycler: ON start	•	•	•	•	•	•	•	•	•	•
87.11	AI	ON delay	•	•	•	•	•	•	•	•	•	•
87.21	DI	ON pulse	•	•	•	•	•	•	•	•	•	•
87.31	SW	Symmetrical recycler: ON start			•							
87.41	BE	Signal OFF delay	•	•	•	•	•	•	•	•	•	•
87.61/ 87.62	BI	True OFF delay (power OFF)		0.15 2.5	•	0.07 1.3		•				
87.82	SD	Star - delta ( $T_{IJ} = -60$ ms)				•						
87.91	LI	Asymmetrical recycler (ON starting)	•	•	•	•	•	•	•	•	•	•
	LE	Signal asymmetrical recycler (ON starting)	•	•	•	•	•	•	•	•	•	•
	PI	Asymmetrical recycler (OFF starting)	•	•	•	•	•	•	•	•	•	•
	PE	Signal asymmetrical recycler (OFF starting)	•	•	•	•	•	•	•	•	•	•

## FUNCTIONS

	LED** Green	Timing	NO output contact	Timed		Contacts DIP switch	Instantaneous*	
				Open	Closed		Open	Closed
<b>U</b> = Supply Voltage		None	Open	15 - 18 25 - 28*	15 - 16 25 - 26*		21 - 24*	21 - 22*
<b>S</b> = Signal switch		In progress	Open	15 - 18 25 - 28*	15 - 16 25 - 26*		21 - 22*	21 - 24*
<b>C</b> = Output Contact		In progress	Closed	15 - 16 25 - 26*	15 - 18 25 - 28*		21 - 22*	21 - 24*
		None	Closed	15 - 16 25 - 26*	15 - 18 25 - 28*			21 - 22*

\* 25-26-28 only for type 87.02 with 2 timed contacts. 21-22-24 only for type 87.02 with 1 instantaneous contact + 1 timed positioning the front DIP switch. \*\* The LED on types 87.61 and 87.62 is illuminated when supply voltage is supplied to timer.

Without signal Start= Start via contact in supply line (A1). With signal Start = Start via contact into control terminal (B1).

### Wiring diagram

#### Multi-function without signal START

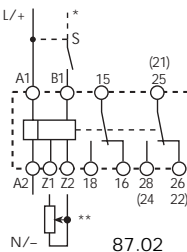
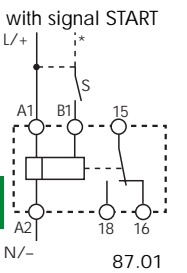
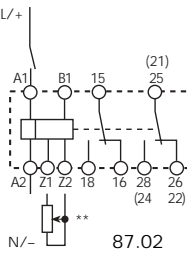
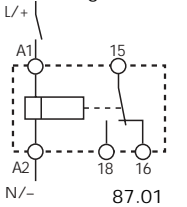

\* A voltage other than the supply voltage can be applied to the command START (B1).  
Example:  
A1 - A2 = 230 V AC/  
B1 - A2 = 24 V AC

\*\* Type 87.02: regulated using an external potentiometer (10 kΩ - 0.25 W).  
NB.: remove link between

Z1-Z2 and position the Timer potentiometer on "zero".

<b>Type 87.01</b> <b>87.02</b>		<b>(AI) ON delay.</b> Apply power to timer. Output contacts transfer after preset time has elapsed. Reset occurs when power is removed.
		<b>(DI) ON pulse.</b> Apply power to timer. Output contacts transfer immediately. After the preset time has elapsed, contacts reset.
		<b>(GI) Fixed pulse (0.5s) delayed.</b> Apply power to timer. Output contacts transfer after preset time has elapsed. Reset occurs after a fixed time of 0.5s. 0.5s.
		<b>(SW) Symmetrical recycler: ON start.</b> Apply power to timer. Output contacts transfer immediately and cycle between ON and OFF for as long as power is applied. The ratio is 1:1 (time on = time off).
		<b>(BE) Signal OFF delay.</b> Power is permanently applied to the timer. The output contacts transfer immediately on closure of the Signal Switch (S). Opening the Signal Switch initiates the preset delay, after which time the output contacts reset.
		<b>(CE) Signal ON and OFF delay.</b> Power is permanently applied to the timer. Closing the Signal Switch (S) initiates the preset delay, after which time the output contacts transfer. Opening the Signal switch initiates the same preset delay, after which time the output contacts reset.
		<b>(DE) Signal ON pulse.</b> Power is permanently applied to the timer. On momentary or maintained closure of Signal Switch (S), the output contacts transfer, and remain so for the duration of the preset delay, after which they reset.
		<b>(EE) Signal OFF pulse.</b> Power is permanently applied to the timer. On opening of the Signal Switch (S) the output contacts transfer, and remain so for the duration of the preset delay, after which they reset.
		<b>Permanently ON.</b> Selecting the function ON when power is applied to the relay the first contact transfers immediately and remains in that position.
	<b>Permanently OFF.</b> The contact returns to the original position when the OFF function is selected.	

**FUNCTIONS**

**Wiring diagram**

**Monofunction**

without signal START

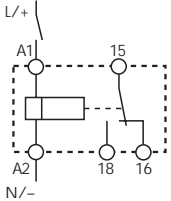

- 87.11
- 87.21
- 87.31
- 87.61

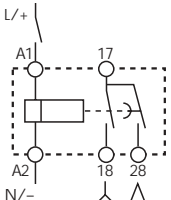

87.62

with signal START (S)

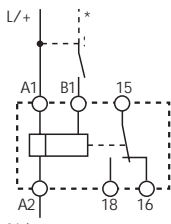

87.41

**Asymmetrical recycler**

without signal START

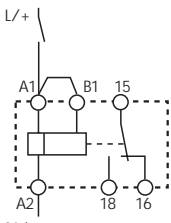

87.91

with signal START (S)

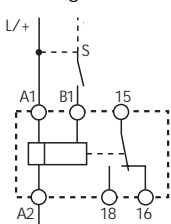

87.91

Type	Timing Diagram	Description
87.11		<b>(AI) ON delay.</b> Apply power to timer. Output contacts transfer after preset time has elapsed. Reset occurs when power is removed.
87.21		<b>(DI) ON pulse.</b> Apply power to timer. Output contacts transfer immediately. After the preset time has elapsed, contacts reset.
87.31		<b>(SW) Symmetrical recycler: ON start.</b> Apply power to timer. Output contacts transfer immediately and cycle between ON and OFF for as long as power is applied. The ratio is 1:1 (time on = time off).
87.61 87.62		<b>(BI) True OFF delay (power OFF).</b> Apply power to timer (minimum 300ms). Output contacts transfer immediately. Removal of power initiates the preset delay, after which time the output contacts reset.
87.82		<b>(SD) Star - delta.</b> Apply power to timer. The star contact (Λ) closes immediately. After preset delay has elapsed the star contact (Λ) resets. After a further fixed time of ~60 ms the delta contact (Δ) closes and remains in that position, until reset on power off.
87.41		<b>(BE) Signal OFF delay.</b> Power is permanently applied to the timer. The output contacts transfer immediately on closure of the Signal Switch (S). Opening the Signal Switch initiates the preset delay, after which time the output contacts reset.

87.91		<b>(LI) Asymmetrical recycler (ON starting).</b> Apply power to timer. Output contacts transfer immediately and cycle between ON and OFF for as long as power is applied. The ON and OFF times are independently adjustable.
		<b>(PI) Asymmetrical recycler (OFF starting).</b> Apply power to timer. Output contacts transfer after time T1 has elapsed and cycle between OFF and ON for as long as power is applied. The ON and OFF times are independently adjustable.
		<b>(LE) Signal asymmetrical recycler (ON starting)</b> Power is permanently applied to the timer. Closing Signal Switch (S) causes the output contacts to transfer immediately and cycle between ON and OFF, until opened.
		<b>(PE) Signal asymmetrical recycler (OFF starting).</b> Power is permanently applied to the timer. Closing the Signal Switch (S) initiates delay T1 after which the output contacts transfer and continue to cycle between OFF and ON, until the Signal Switch is opened.

- 8 - 11 pin plug-in version available
- Multi-voltage and multi-function versions available
- Time scales from 0.05s to 100h
- "1 delayed contact + 1 instantaneous contact" version available (type 88.12)
- Sockets: 90 series

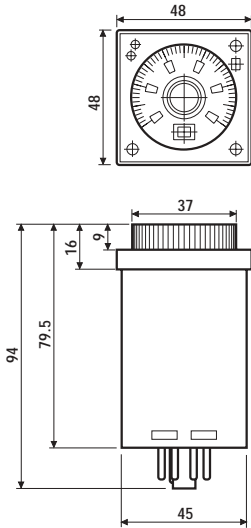

## 88.02



- Multi-function
- 11 pin
- Plug-in for use with 90 series sockets

**AE:** Signal ON delay  
**BE:** Signal OFF delay  
**DE:** Signal ON pulse

with signal START

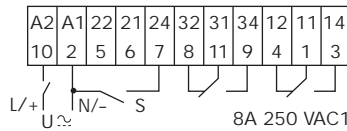

**AI:** ON delay  
**HI:** ON pulse  
**SW:** Symmetrical recycle: ON start

without signal START

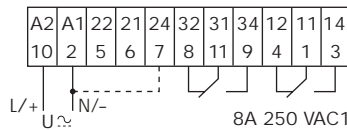

## 88.12



- Multi-function
- 8 pin, 2 timed contacts or 1 timed + 1 instantaneous contact
- Plug-in for use with 90 series sockets

**AI a:** ON Delay (2 timed contacts)  
**AI b:** ON Delay (1 timed + 1 instantaneous contact)  
**DI a:** ON Pulse (2 timed contacts)  
**DI b:** ON Pulse (1 timed + 1 instantaneous contact)

without signal START

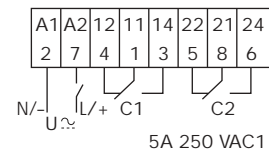

Contact specifications			
Contact configuration		2 CO	2 CO
Rated current/Maximum peak current	A	8/15	5/10
Rated voltage/Maximum switching voltage	V AC	250/250	250/400
Rated load in AC1	VA	2,000	1,250
Rated load in AC15 (230 VAC)	VA	400	250
Single phase motor rating (230 VAC)	kW	0.3	0.125
Breaking capacity in DC1:	30/110/220V A	8/0.3/0.12	5/0.3/0.12
Minimum switching load	mW(V/mA)	300 (5/5)	500 (5/5)
Standard contact material		AgNi	AgCdO
Supply specifications			
Nominal voltage	V AC(50/60Hz)	24...230	24...230
	V DC	24...230	24...48
Rated power AC/DC	VA (50Hz)/W	3.5 (230 V)/1 (24 V)	9 (230 V)/1 (24 V)
Operating range	AC	20.4...264.5	20.4...264.5
	DC	20.4...264.5	20.4...55.2
Technical data			
Specified time range		(0.05s...5h) - (0.05s...10h) - (0.05s...50h) - (0.05s...100h)	
Repeatability	%	± 1	± 1
Recovery time	ms	300	200
Minimum control impulse	ms	50	—
Setting accuracy-full range	%	± 3	± 3
Electrical life at rated load in AC1	cycles	100·10 <sup>3</sup>	100·10 <sup>3</sup>
Ambient temperature range	°C	-10...+55	-10...+55
Protection category		IP 40	IP 40
<b>Approvals:</b> (according to type)			

## ORDERING INFORMATION

Example: 88 series multi-function timer, 2 CO contact 8 A, with (24...230) V AC (50/60) Hz and (24...230) V DC supply.

**8 8 . 0 2 . 0 . 2 3 0 . 0 0 0 0**

**Series**

**Type**

0 = Functions AI, SW, AE, BE, DE, HI  
1 = Functions AI a, AI b, DI a, DI b

**No. of poles**

2 = 2 pole

**Supply voltage**

230 =  $\begin{cases} 24...230 \text{ V AC} \\ 24...48 \text{ V DC} \end{cases}$  (for type 88.12)

230 = 24...230 V AC/DC (for type 88.02)

**Supply version**

0 = AC (50/60 Hz)/DC

## TECHNICAL DATA

### EMC SPECIFICATIONS

TYPE OF TEST	REFERENCE STANDARD	
ELECTROSTATIC DISCHARGE	- contact discharge	EN 61000-4-2
	- air discharge	EN 61000-4-2
RADIO-FREQUENCY ELECTROMAGNETIC FIELD (80 ÷ 1000 MHz)	EN 61000-4-3	10 V/m
FAST TRANSIENTS (burst) (5-50 ns, 5 kHz) on Supply terminals	EN 61000-4-4	2 kV/5 kV
SURGES (1.2/50 µs) on Supply terminals	- common mode	EN 61000-4-5
	- differential mode	EN 61000-4-5
RADIO-FREQUENCY COMMON MODE (0.15 ÷ 80 MHz) on Supply terminals	EN 61000-4-6	3 V

## TIME SCALES

### END SCALE

	s	min	h	x10 h
<b>0.5</b>	0.5 s	0.5 min	0.5 h	5 h
<b>1</b>	1 s	1 min	1 h	10 h
<b>5</b>	5 s	5 min	5 h	50 h
<b>10</b>	10 s	10 min	10 h	100 h

## TIME SCALES AND FUNCTIONS SELECTION

		88.02	88.12
<b>E</b>	<b>Function selector</b>	AE, AI, BE, DE, HI, SW	AI a, AI b, DI a, DI b
<b>D</b>	<b>Time scale selector</b>	0.5, 1, 5, 10	0.5, 1, 5, 10
<b>H</b>	<b>Unit of time selector</b>	s, min, h, 10h	s, min, h, 10h

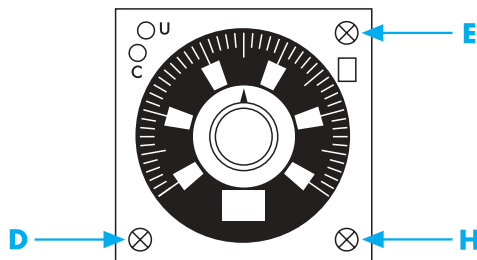

**FUNCTIONS**

**U** = Supply Voltage  
**S** = Signal switch  
**C** = Output Contact

Without signal Start= Start via contact in supply line (A1).  
 With signal Start = Start via contact into control terminal (7/24).

**Wiring diagram**

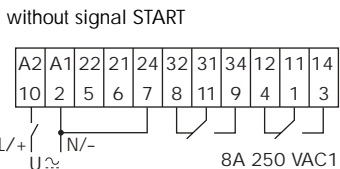
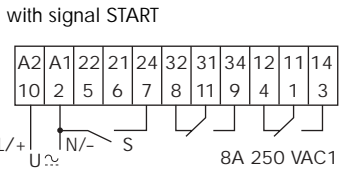
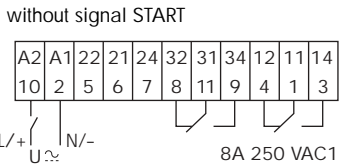

**Type 88.02**

**(AI) ON delay.**  
 Apply power to timer. Output contacts transfer after preset time has elapsed. Reset occurs when power is removed.

**(SW) Symmetrical recycler: ON start.**  
 Apply power to timer. Output contacts transfer immediately and cycle between ON and OFF for as long as power is applied. The ratio is 1:1 (time on = time off).

**(AE) ON delay.**  
 When power is applied, the timer will function as an ON delay except when the Signal Switch (S) is closed which will force the output and the timing process into the reset condition.

**(BE) Signal OFF delay.**  
 Power is permanently applied to the timer. The output contacts transfer immediately on closure of the Signal Switch (S). Opening the Signal Switch initiates the preset delay, after which time the output contacts reset.

**(DE) Signal ON pulse.**  
 Power is permanently applied to the timer. On momentary or maintained closure of Signal Switch (S), the output contacts transfer, and remain so for the duration of the preset delay, after which they reset.

**(HI) ON pulse.**  
 Apply power to timer. Output contacts transfer immediately. After preset time has elapsed, contacts reset.

N.B. Ensure a fixed connection between Terminals 2 and 7.

**Type 88.12**

**(AI a) ON Delay (2 timed contacts).**  
 Apply power to timer. Contacts (C<sub>1</sub> and C<sub>2</sub>) transfer after preset time has elapsed. Reset occurs when power is removed.

**(AI b) ON Delay (1 timed contact + 1 instantaneous contact).**  
 Apply power to timer. Output contact (C<sub>1</sub>) transfers immediately. Contact (C<sub>2</sub>) transfers after the preset time has elapsed. Reset occurs when power is removed.

**(DI a) ON pulse (2 timed contacts).**  
 Apply power to timer. Output contacts (C<sub>1</sub> and C<sub>2</sub>) transfer immediately. After preset time has elapsed, the contacts reset.

**(DI b) ON pulse (1 timed contact + 1 instantaneous contact).**  
 Apply power to timer. Output contacts (C<sub>1</sub> and C<sub>2</sub>) transfer immediately. After preset time has elapsed, the contact (C<sub>2</sub>) resets. Contact (C<sub>1</sub>) resets when power is removed.

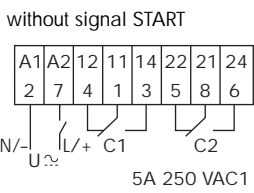



90.21

Approvals  
(according to type):



- RATED VALUES: 10 A - 250 V
- DIELECTRIC STRENGTH:  $\geq 2$  kV AC
- PROTECTION CATEGORY: IP 20
- AMBIENT TEMPERATURE: (-40...+70)°C
- TORQUE: 0.5 Nm
- WIRE STRIP LENGTH: 10 mm
- MAX WIRE SIZE:

	solid wire	stranded wire
mm <sup>2</sup>	1x6 / 2x2.5	1x6 / 2x2.5
AWG	1x10 / 2x14	1x10 / 2x14

Timer type	88.12		88.02	
Colour	BLUE	BLACK	BLUE	BLACK
Clamp terminal socket: panel or 35 mm rail (EN 50022) mount	90.20	90.20.0	90.21	90.21.0

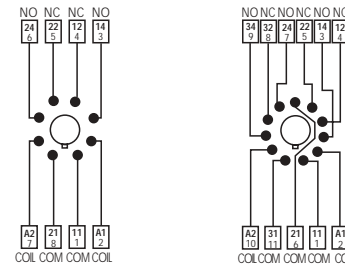
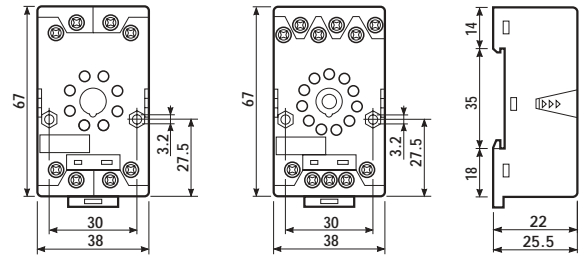

90.20

90.21



90.26

Approvals  
(according to type):



- RATED VALUES: 10 A - 250 V
- DIELECTRIC STRENGTH:  $\geq 2$  kV AC
- PROTECTION CATEGORY: IP 20
- AMBIENT TEMPERATURE: (-40...+70)°C
- TORQUE: 0.8 Nm
- WIRE STRIP LENGTH: 11 mm
- MAX WIRE SIZE:

	solid wire	stranded wire
mm <sup>2</sup>	1x4 / 2x2.5	1x4 / 2x2.5
AWG	1x12 / 2x14	1x12 / 2x14

Timer type	88.12		88.02	
Colour	BLUE	BLACK	BLUE	BLACK
Screw terminal socket: panel or 35 mm rail (EN 50022) mount	90.26	90.26.0	90.27	90.27.0

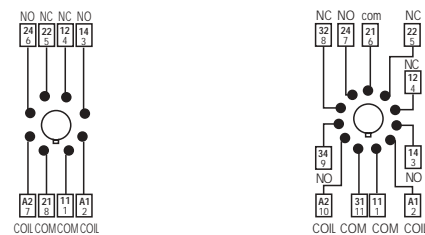
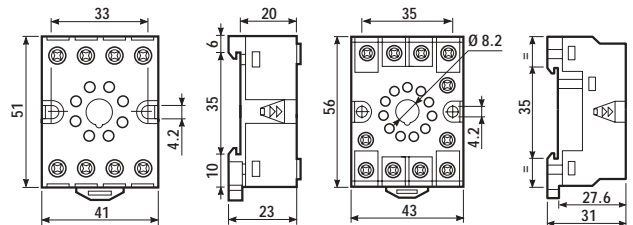

90.26

90.27



90.13.4

Approvals  
(according to type):



- RATED VALUES: 10 A - 250 V
- DIELECTRIC STRENGTH:  $\geq 2$  kV AC
- AMBIENT TEMPERATURE: (-40...+70)°C

Timer type	88.12		88.02	
Colour	BLUE	BLACK	BLUE	BLACK
Sockets 8-11 pin backwired with solder terminals	—	90.12.4	—	90.13.4

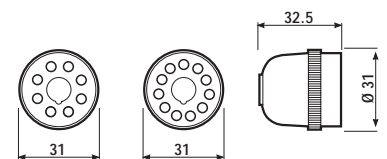

90.12.4

90.13.4

- A range of light dependent relays with 1 or 2 NO contacts
- Pole or flange mounting
- Double break (phase + neutral) type available (type 10.32)
- Sensitivity adjustment from 1 to 50 lux

	10.32	10.41
	- 2 NO, 16 A - Pole mount	- 1 NO, 12 A - Pole mount
<b>Contact specifications</b>		
Contact configuration	2 NO	1 NO
Rated current/Max. peak current	A 16/30 (100 A · 5 ms)	12/25 (100 A · 5 ms)
Rated voltage/Max. switching voltage	V AC 230/—	230/—
Rated load in AC1	VA 3,700	2,800
Rated load in AC15 (230 VAC)	VA 700	600
Nominal lamp rating: incandescence (230V)	W 2,000	1,200
compensated fluorescent (230V)	W 750	420
uncompensated fluorescent (230V)	W 1,000	600
halogens (230V)	W 2,000	1,200
Minimum switching load	mW(V/mA) 1,000 (10/10)	1,000 (10/10)
Standard contact material	AgSnO <sub>2</sub>	AgSnO <sub>2</sub>
<b>Supply specifications</b>		
Nominal voltage	V AC (50/60Hz) 230	230
	V DC —	—
Rated power AC/DC	VA (50Hz)/W 2.5/—	2/—
Operating range	AC (50Hz) (0.85...1.1)U <sub>N</sub>	(0.8...1.1)U <sub>N</sub>
	DC —	—
<b>Technical data</b>		
Electrical life at rated load in AC1	cycles 100 · 10 <sup>3</sup>	100 · 10 <sup>3</sup>
Threshold setting	lx 1...80 (switching ON)	1...80 (switching ON)
	lx 2...150 (switching OFF)	2...150 (switching OFF)
Delay time: switching ON/OFF	s 6/25	15/25
Ambient temperature range	°C -30...+70	-30...+70
Protection category	IP 54	IP 54
<b>Approvals:</b> (according to type)		



## ORDERING INFORMATION

Example: a 10 series light dependent relay with 1 NO - 12 A contact and screw terminal connections, with 230 V AC supply.

**1 0 . 4 1 . 8 . 2 3 0 . 0 0 0 0**

**Series** \_\_\_\_\_

**Type** \_\_\_\_\_  
 3 = Pole mount - 2 NO  
 4 = Pole mount - 1 NO

**No. of poles** \_\_\_\_\_  
 1 = Single phase switch 1 NO, 12 A  
 2 = Double phase switch 2 NO, 16 A

**Supply voltage**  
 230 = 230 V

**Supply version**  
 8 = AC (50/60 Hz)

## TECHNICAL DATA

<b>INSULATION</b>		<b>10.32</b>	<b>10.41</b>		
DIELECTRIC STRENGTH - between open contacts	V AC	1,000	1,000		
<b>OTHER DATA</b>		<b>10.32</b>	<b>10.41</b>		
CABLE GRIP	Ø mm	(8.9...13)	(8.9...13)		
PRESET THRESHOLD	lx	5 switch ON / 20 switch OFF	3 switch ON / 8 switch OFF		
MAX WIRE SIZE		solid cable	stranded cable	solid cable	stranded cable
	mm <sup>2</sup>	1x6 / 2x4	1x6 / 2x2.5	1x6 / 2x4	1x6 / 2x2.5
	AWG	1x10 / 2x12	1x10 / 2x14	1x10 / 2x12	1x10 / 2x14
SCREW TORQUE	Nm	1.2	1.2		

## WIRING DIAGRAMS

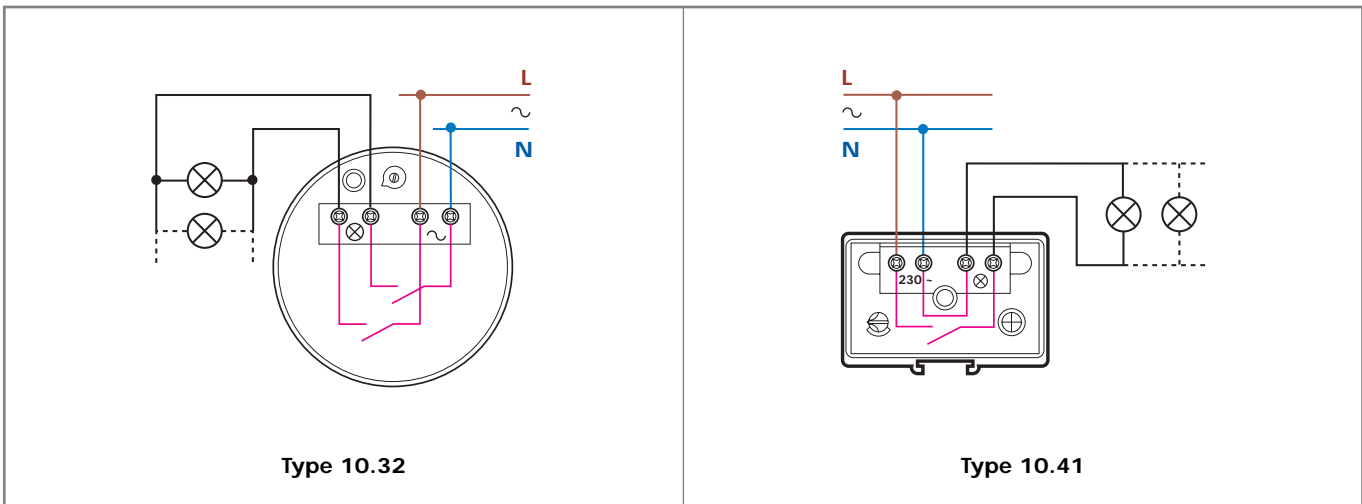

- Type 11.01 is suitable for use on staircases and in entrance halls.
- Selector with 3 positions:**
- **high range** (threshold setting 20...1000lx)
- **low range** (threshold setting 1...30lx)
- **continuous light** (particularly interesting for the Test at the first installation).
- Type 11.71: with 1 CO contact and with 12...24 VAC/DC voltage supply.
- SELV separation between contact and supply circuit.
- Supplied with separate sensitive photocell.
- LED indication.
- 35 mm rail (EN 50022) mount.

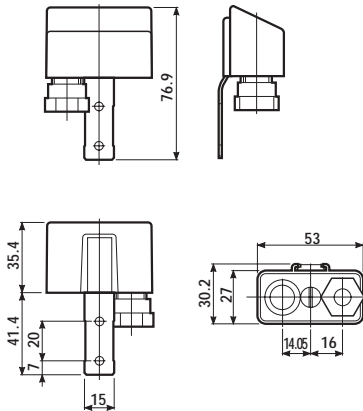

O11.00

Sensitive photocell

## 11.01

## 11.71

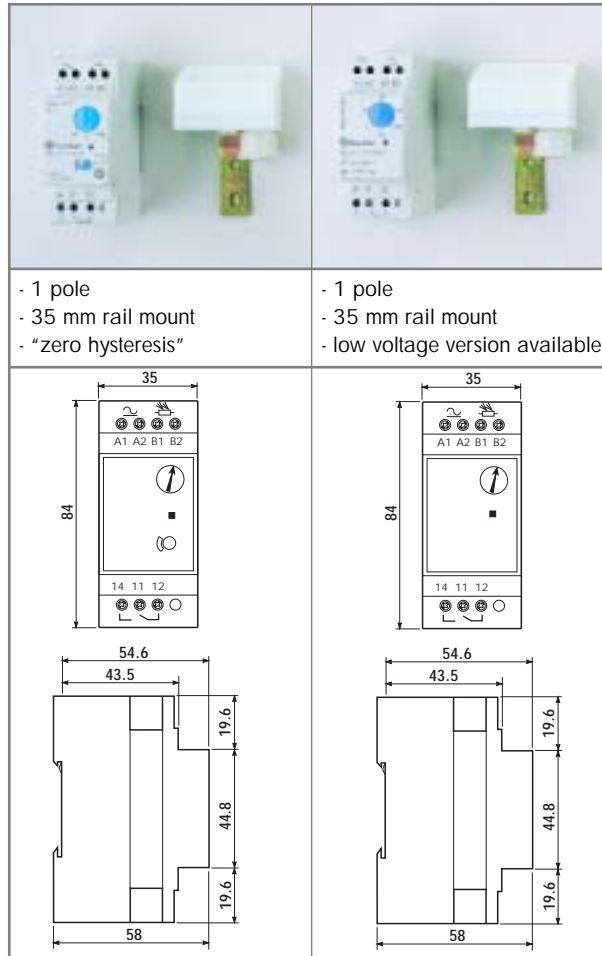

- 1 pole
- 35 mm rail mount
- "zero hysteresis"

- 1 pole
- 35 mm rail mount
- low voltage version available

Contact specifications		11.01	11.71
Contact configuration		1 CO	1 CO
Rated current/Max. peak current	A	16/30 (100 A · 5 ms)	16/30 (100 A · 5 ms)
Rated voltage/Max. switching voltage	V AC	250/400	250/400
Rated load in AC1	VA	4,000	4,000
Rated load in AC15 (230 VAC)	VA	750	750
Nominal lamp rating: incandescence (230V)	W	2,000 (NO contact)	2,000 (NO contact)
compensated fluorescent (230V)	W	550 (NO contact)	550 (NO contact)
uncompensated fluorescent (230V)	W	1,000 (NO contact)	1,000 (NO contact)
halogens (230V)	W	2,000 (NO contact)	2,000 (NO contact)
Minimum switching load	mW(V/mA)	1,000 (10/10)	1,000 (10/10)
Standard contact material		AgSnO <sub>2</sub>	AgSnO <sub>2</sub>
Supply specifications		11.01	11.71
Nominal voltage	V DC/AC (50/60Hz)	—	12...24
	V AC (50/60Hz)	230	110...125   230...240
Rated power AC/DC	VA (50Hz)/W	2/—	1.3/0.8
Operating range	DC/AC (50Hz)	—	(9.6...33.6) V
	AC (50Hz)	(0.8...1.1)U <sub>N</sub>	(88...137) V   (184...264) V
Technical data		11.01	11.71
Electrical life at rated load in AC1	cycles	100 · 10 <sup>3</sup>	100 · 10 <sup>3</sup>
Threshold setting	lx	1...30 (low range)	1...100 (switching ON)
	lx	20...1,000 (high range)	2...150 (switching OFF)
Delay time: switching ON/OFF	s	15/25	15/25
Ambient temperature range	°C	-20...+50	-20...+60
Protection category: light dependent relay/photocell		IP 20/IP 54	IP 20/IP 54
<b>Approvals:</b> (according to type)			

## ORDERING INFORMATION

Example: a 11 series light dependent relay "zero hysteresis" with 1 CO - 16 A contact and 35 mm rail mounting, with 230 V AC supply.

**1 1 . 0 1 . 8 . 2 3 0 . 0 0 0 0**

Series

Type

0 = 35 mm rail (EN 50022) mounting, "zero hysteresis"  
7 = 35 mm rail (EN 50022) mounting

No. of poles

1 = 1 pole

Supply voltage

024 = 12...24 V AC/DC for 11.71 only  
125 = 110...125 V AC for 11.71 only  
230 = 230...240 V AC for 11.71 only  
230 = 230 V AC for 11.01 only

Supply version

0 = AC (50/60 Hz)/DC for 11.71.0.240 only  
8 = AC (50/60 Hz)

## TECHNICAL DATA

INSULATION		11.01	11.71
DIELECTRIC STRENGTH			
- between supply and contacts	V AC	4,000	4,000
- between open contacts	V AC	1,000	1,000
OTHER DATA		11.01	11.71
CABLE GRIP of SENSITIVE PHOTOCELL	Ø mm	(7.5...9)	(7.5...9)
PRESET THRESHOLD	lx	10	100
POWER LOST TO THE ENVIRONMENT			
- without contact current	W	1.3	0.8
- with rated current	W	3.1	2
MAX WIRE SIZE			
		solid cable	stranded cable
	mm <sup>2</sup>	1x6 / 2x4	1x6 / 2x2.5
	AWG	1x10 / 2x12	1x10 / 2x14
SCREW TORQUE		Nm	0.8

## WIRING DIAGRAMS

**Type 11.01**  
RED LED indication:  
Blinking = power ON, relay OFF  
Continuous = power ON, relay ON

**Type 11.71**  
RED LED indication:  
Slow blinking = power ON, relay OFF  
Fast blinking = power ON, timing in progress  
Continuous = power ON, relay ON

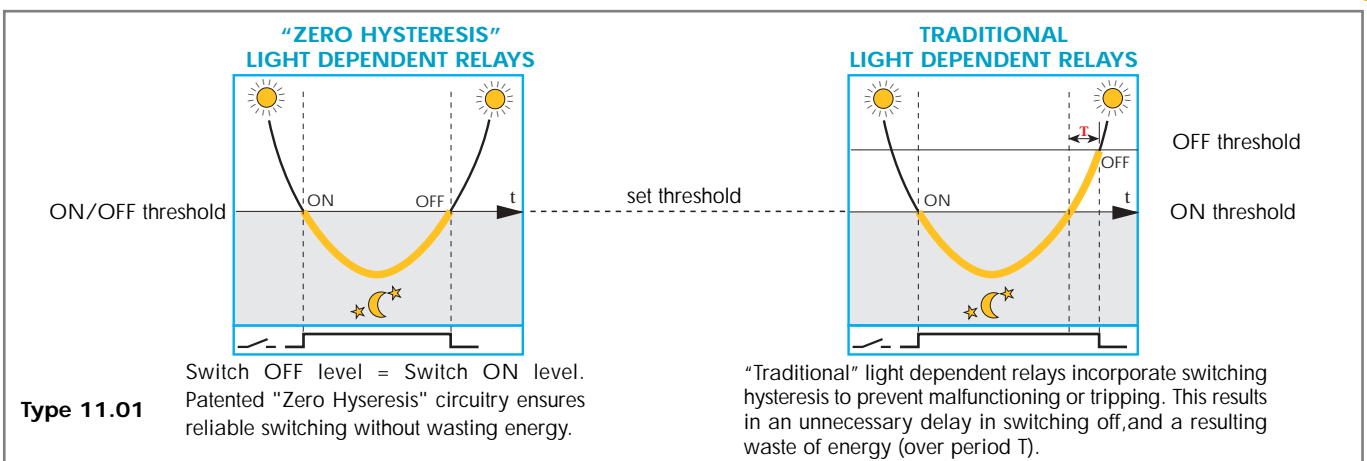

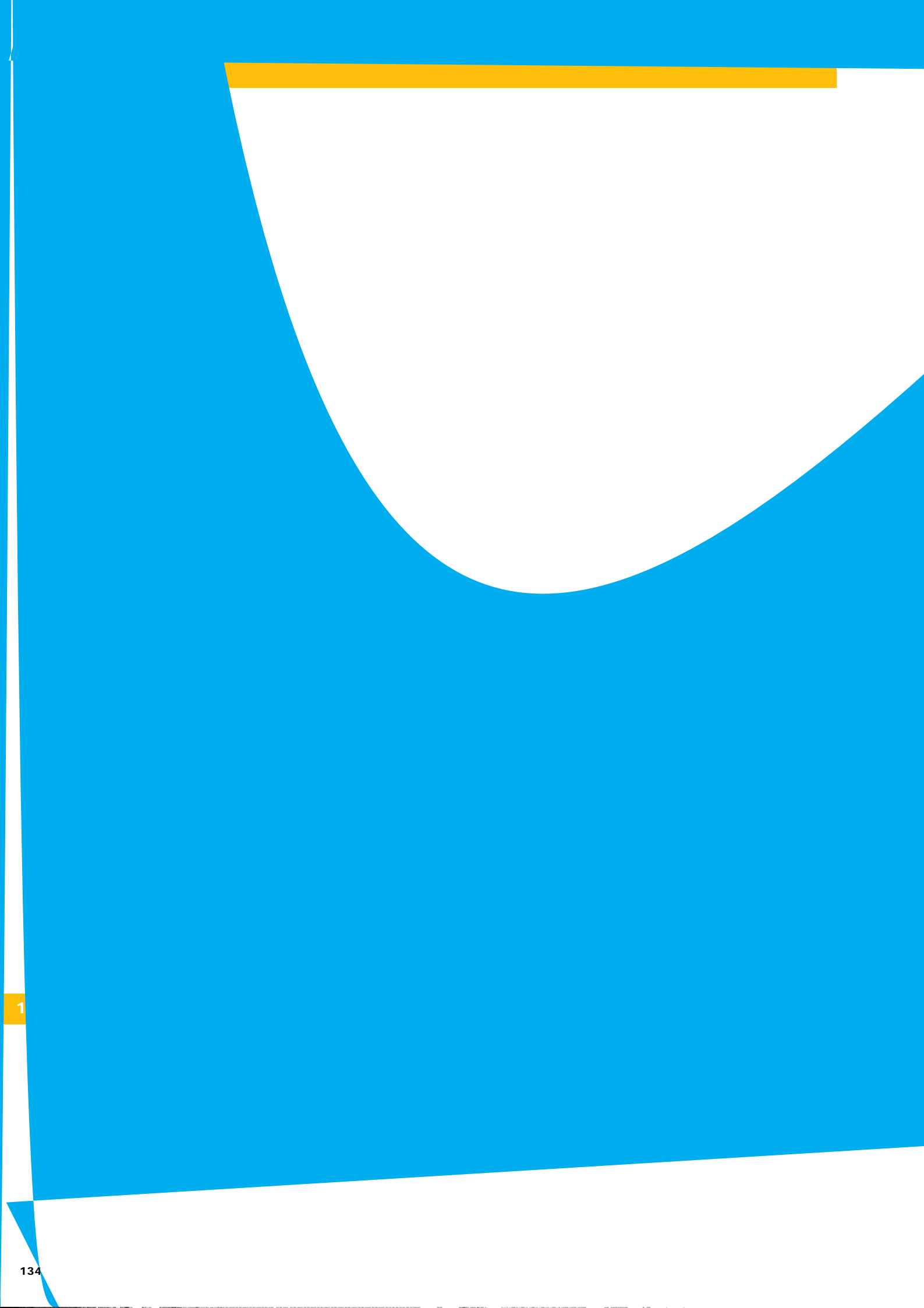

## ORDERING INFORMATION

Example: a 12 series, mechanical daily time switch, 1 CO - 16 A, supply voltage 230 V AC.

<b>1</b>	<b>2</b>	<b>.</b>	<b>0</b>	<b>1</b>	<b>.</b>	<b>8</b>	<b>.</b>	<b>2</b>	<b>3</b>	<b>0</b>	<b>.</b>	<b>0</b>	<b>0</b>	<b>0</b>	<b>0</b>
<b>Series</b>			<b>Type</b>			<b>No. of poles</b>			<b>Supply voltage</b>						
0 = Daily 2 = Weekly			0 = Daily 2 = Weekly			1 = 1 CO, 16 A 2 = 2 CO, 16 A			230 = 230 V						
									8 = AC (50/60 Hz)						

## TECHNICAL DATA

<b>INSULATION</b>		<b>12.01</b>		<b>12.21/12.22</b>	
DIELECTRIC STRENGTH - between open contacts	V	1,000		1,000	
<b>OTHER DATA</b>		<b>12.01</b>		<b>12.21/12.22</b>	
POWER BACK-UP		70 h after 80 h uninterrupted supply		6 years after the first operation	
POWER LOST IN THE ENVIRONMENT - without contact current	W	1.5		2	
	W	2.5		3 ( 1 CO)	4 ( 2 CO)
MAX WIRE SIZE		solid cable	stranded cable	solid cable	stranded cable
	mm <sup>2</sup>	1x6 / 2x4	1x6 / 2x2.5	1x6 / 2x4	1x6 / 2x2.5
	AWG	1x10 / 2x12	1x10 / 2x14	1x10 / 2x12	1x10 / 2x14
SCREW TORQUE	Nm	1.2		1.2	

## WIRING DIAGRAMS

**Type 12.01**  
SELECTOR SWITCH:  
Permanently OFF (0)  
Automatic (AUTO)  
Permanently ON (I)

**Type 12.21  
12.22**

- Electronic step relays
- Control circuit can be used continuously
- Longer mechanical and electrical life, and much quieter than electromechanical step relays
- Suitable for SELV applications (according to IEC 364), type 13.01
- 35 mm rail (EN 50022) or flange mount

### 13.01

### 13.71



- Low voltage supply 12-24 V
- Step or monostable relay
- 35 mm rail mount

- 1 NO
- Panel mount
- Screw terminals

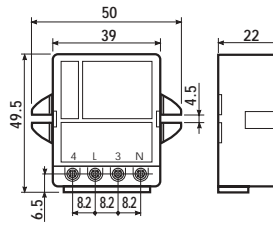
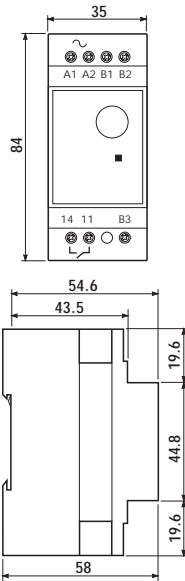

Contact specifications			
Contact configuration		1 NO	1 NO
Rated current/Max. peak current	A	16/30 (100 A · 5 ms)	10/20 (100 A · 5 ms)
Rated voltage/Max. switching voltage	V AC	250/400	230/—
Rated load in AC1	VA	4,000	2,300
Rated load in AC15 (230 VAC)	VA	750	450
Nominal lamp rating: incandescence (230V)	W	2,000	1,000
compensated fluorescent (230V)	W	750	350
uncompensated fluorescent (230V)	W	1,000	500
halogens (230V)	W	2,000	1,000
Minimum switching load	mW(V/mA)	1,000 (10/10)	1,000 (10/10)
Standard contact material		AgSnO <sub>2</sub>	AgSnO <sub>2</sub>
Supply specifications			
Nominal voltage	V AC (50/60Hz)	12-24-110...125 - 230...240	230
	V DC	12 - 24	—
Rated power AC/DC	V AC (50Hz)/W	2.5/2.5	1.5/—
Operating range	AC (50Hz)	(0.8...1.1)U <sub>N</sub>	(0.85...1.15)U <sub>N</sub>
	DC	(0.9...1.1)U <sub>N</sub>	—
Technical data			
Electrical life at rated load in AC1	cycles	100 · 10 <sup>3</sup>	100 · 10 <sup>3</sup>
Maximum impuls duration		continuous	continuous
Dielectric strenght between:	open contacts V AC	1,000	1,000
	supply contacts V AC	4,000	—
Ambient temperature range	°C	-10...+60	-10...+60
Protection category		IP 20	IP 20
Approvals: (according to type)			

## ORDERING INFORMATION

Example: a 13 series, electronic step or monostable relay, 35 mm rail mount and 1 NO - 16 A contact, with 230 V AC supply.

**1 3 . 0 1 . 8 . 2 3 0 . 0 0 0 0**

**Series**

**Type**

0 = 35 mm rail (EN 50022) mount  
7 = Panel mount

**No. of poles**

1 = Single phase switch 1 NO

**Supply voltage**

012 = 12 V AC/DC

024 = 24 V AC/DC

125 = 110...125 V AC

230 = 230...240 V AC

230 = 230 VAC (13.71 only)

**Supply version**

0 = AC (50/60 Hz)/DC (for 13.01.0.012 and 13.01.0.024 only)

8 = AC (50/60 Hz)

## TECHNICAL DATA

### INSULATION

**13.01**

**13.71**

DIELECTRIC STRENGTH		13.01	13.71
- between control circuit and supply	V AC	4,000	—
- between control circuit and contacts	V AC	4,000	—
- between supply and contacts	V AC	4,000	—
- between open contacts	V AC	1,000	1,000

### OTHER DATA

**13.01**

**13.71**

POWER LOST IN THE ENVIRONMENT		13.01		13.71	
- without contact current	W	2.2		0.5	
- with rated current	W	3.5		2.9	
MAX WIRE SIZE		solid cable		stranded cable	
	mm <sup>2</sup>	1x6 / 2x4		1x4 / 2x2.5	1x2.5 / 2x2.5
	AWG	1x10 / 2x12		1x10 / 2x14	1x14 / 2x14
SCREW TORQUE	Nm	0.8			

## WIRING DIAGRAMS

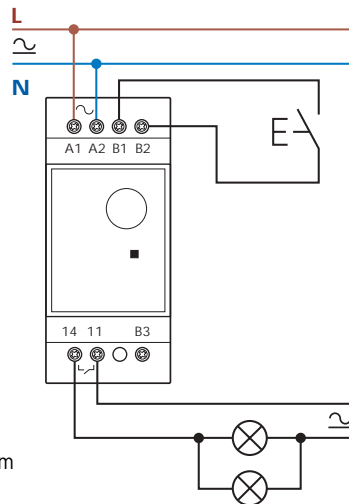

**Type 13.01**  
Bistable (step) wiring diagram

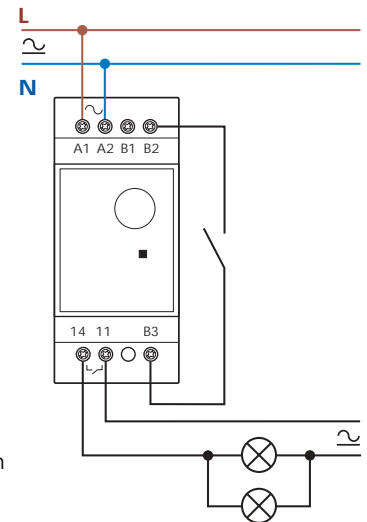

**Type 13.01**  
Monostable wiring diagram

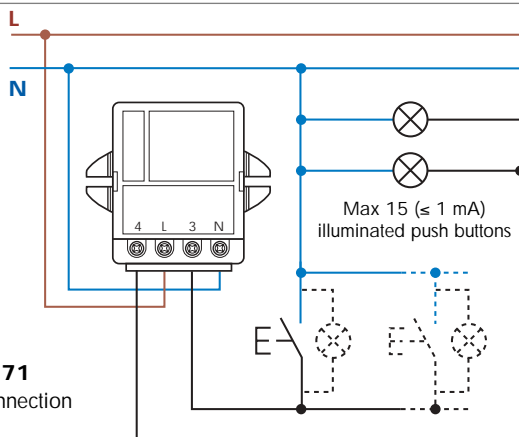

**Type 13.71**  
3 wire connection

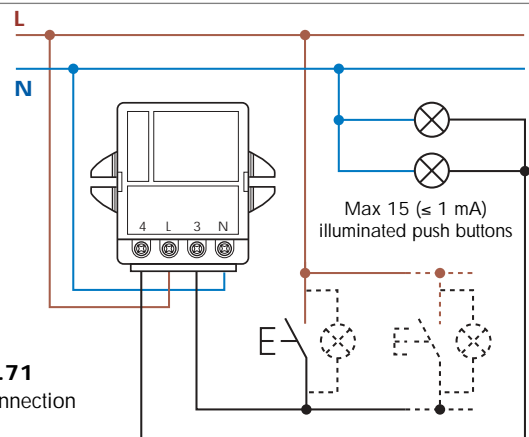

**Type 13.71**  
4 wire connection

- One module (17.4 mm) wide
- Time range from 30 s to 20 min
- Can be used with illuminated push - buttons
- Suitable for 3 or 4 wiring systems
- LED indicators
- 35 mm rail (EN 50022) mount

	14.01	14.71
	- Multi-function - 1 NO - 35 mm rail mount	- For 3 or 4 wiring system - 1 NO - 35 mm rail mount
<b>Contact specifications</b>		
Contact configuration	1 NO	1 NO
Rated current/Max. peak current	A 16/30 (100 A - 5 ms)	A 16/30 (100 A - 5 ms)
Rated voltage/Max. switching voltage	V AC 230/—	V AC 230/—
Rated load in AC1	VA 3,700	VA 3,700
Rated load in AC15 (230 VAC)	VA 750	VA 750
Nominal lamp rating: incandescence (230V)	W 2,000	W 2,000
compensated fluorescent (230V)	W 750	W 750
uncompensated fluorescent (230V)	W 1,000	W 1,000
halogens (230V)	W 2,000	W 2,000
Minimum switching load	mW(V/mA) 1,000 (10/10)	mW(V/mA) 1,000 (10/10)
Standard contact material	AgSnO <sub>2</sub>	AgSnO <sub>2</sub>
<b>Supply specifications</b>		
Nominal voltage	V AC (50/60Hz) 230	V AC (50/60Hz) 230
	V DC —	V DC —
Rated power AC/DC	VA (50Hz)/W 2/—	VA (50Hz)/W 1.5/—
Operating range	AC (50Hz) (0.8...1.1)U <sub>N</sub>	AC (50Hz) (0.8...1.1)U <sub>N</sub>
	DC —	DC —
<b>Technical data</b>		
Electrical life at rated load in AC1	cycles 100 · 10 <sup>3</sup>	cycles 100 · 10 <sup>3</sup>
Delay setting	min 0.5...20	min 0.5...20
Max no. of illuminated push-button (≤1mA)	15	30
Maximum impulse duration	continuous	continuous
Ambient temperature range	°C -10...+50	°C -10...+60
Protection category	IP 20	IP 20
<b>Approvals:</b> (according to type)	GOST	GOST



## ORDERING INFORMATION

Example: a 14 series single module relay with a single phase switch 1 NO - 16 A contact, with supply rated at 230 V AC.

**1 4 . 0 1 . 8 . 2 3 0 . 0 0 0 0**

**Series**

**Type**

0 = 35 mm rail (EN 50022) mount, multi-function  
7 = 35 mm rail (EN 50022) mount

**No. of poles**

1 = Single phase switch, 16 A

**Supply voltage**

230 = 230 V

**Supply version**

8 = AC (50/60 Hz)

## TECHNICAL DATA

### INSULATION

14.01

14.71

DIELECTRIC STRENGTH			
- between open contacts	V AC	1,000	1,000

### OTHER DATA

14.01

14.71

POWER LOST IN THE ENVIRONMENT					
- without contact current	W	1.3	1		
- with rated current	W	3.3	3.3		
MAX WIRE SIZE		solid cable	stranded cable	solid cable	stranded cable
	mm <sup>2</sup>	1x6 / 2x4	1x4 / 2x2.5	1x6 / 2x4	1x4 / 2x2.5
	AWG	1x10 / 2x12	1x12 / 2x14	1x10 / 2x12	1x12 / 2x14
SCREW TORQUE	Nm	0.8		0.8	

## WIRING DIAGRAMS

### Type 14.01

LED indication:  
red = relay ON  
green = power ON

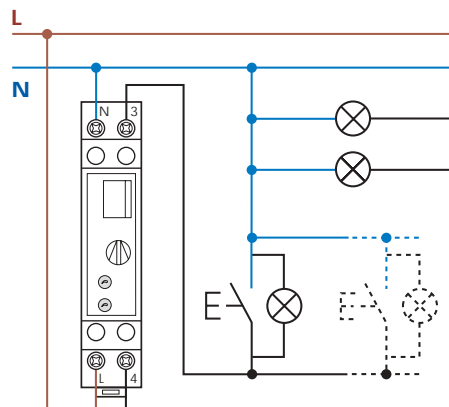

3 wire connection

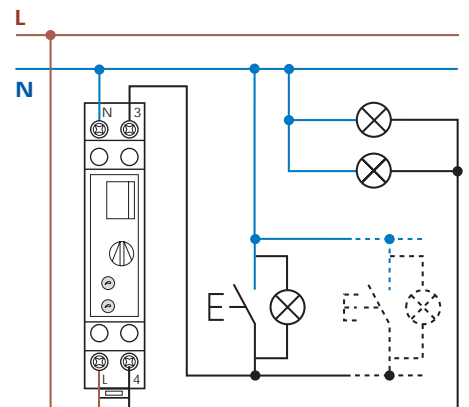

4 wire connection

### Type 14.71

LED indication:  
red = relay ON

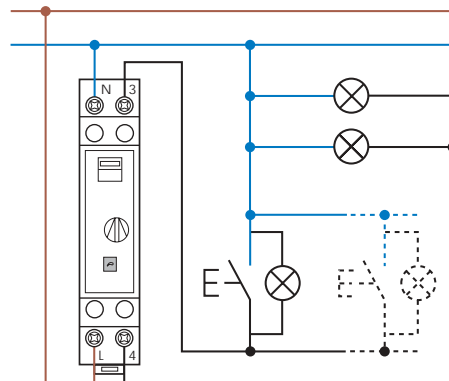

3 wire connection



4 wire connection

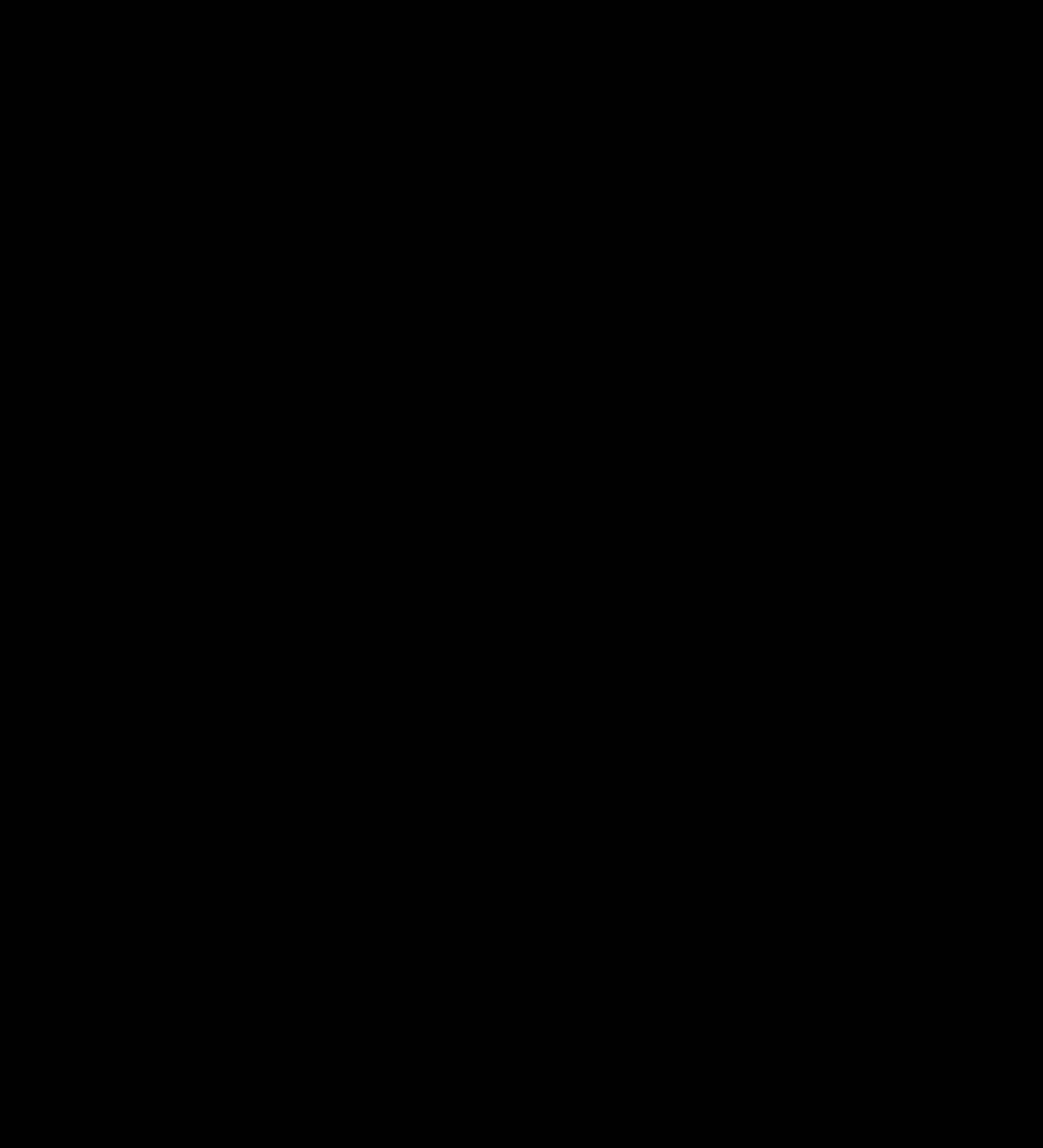

- One module (17.4mm) wide
- Test button with mechanical indicators
- 6 functions available
- AC and DC coils
- Identification label
- Possible to connect illuminated push buttons
- 35 mm rail (EN 50022) mount

	20.21	20.22, 24, 26, 28	20.23
	- Single phase switch 1 NO - 35 mm rail mount	- Double phase switch - 35 mm rail mount	- Double phase switch 1 NC + 1 NO - 35 mm rail mount
<b>Contact specifications</b>			
Number of contacts	1 NO	2 NO	1 NC + 1 NO
Rated current/Max. peak current A	16/30	16/30	16/30
Rated voltage/Max. switching voltage V AC	250/400	250/400	250/400
Rated load in AC1 VA	4,000	4,000	4,000
Rated load in AC15 (230 VAC) VA	750	750	750
Nominal lamp rating: incandescence (230V) W	2,000	2,000	2,000
compensated fluorescent (230V) W	750	750	750
uncompensated fluorescent (230V) W	1,000	1,000	1,000
halogens (230V) W	2,000	2,000	2,000
Minimum switching load mW(V/mA)	1,000 (10/10)	1,000 (10/10)	1,000 (10/10)
Standard contact material	AgNi	AgNi	AgNi
<b>Coil specifications</b>			
Nominal voltage V AC (50/60Hz)	8 - 12 - 24 - 48 - 110 - 120 - 230 - 240		
V DC	12 - 24 - 48 - 110	12 - 24 - 48 - 110	12 - 24 - 48 - 110
Rated power AC/DC VA (50Hz)/W	5.5/5	5.5/5	5.5/5
Operating range AC	(0.85...1.1)U <sub>N</sub> (50Hz)/(0.9...1.1)U <sub>N</sub> (60Hz)		
V DC	(0.9...1.1)U <sub>N</sub>	(0.9...1.1)U <sub>N</sub>	(0.9...1.1)U <sub>N</sub>
<b>Technical data</b>			
Mechanical life cycles	300 · 10 <sup>3</sup>	300 · 10 <sup>3</sup>	300 · 10 <sup>3</sup>
Electrical life at rated load in AC1 cycles	100 · 10 <sup>3</sup>	100 · 10 <sup>3</sup>	100 · 10 <sup>3</sup>
Maximum impulse duration	1 h (according to EN60669)	1 h (according to EN60669)	1 h (according to EN60669)
Insulation between coil and contacts (1.2/50µs) kV	4	4	4
Ambient temperature range °C	-40...+40	-40...+40	-40...+40
Protection category	IP 20	IP 20	IP 20
<b>Approvals:</b> (according to type)			

## ORDERING INFORMATION

Example: a 20 series 35 mm rail (EN 50022) mount relay with double phase switch, 2 NO - 16 A contacts, coil rated at 12 V DC and with AgSnO<sub>2</sub> contacts.

**2 0 . 2 2 . 9 . 0 1 2 . 4 0 0 0**

**Series**

**Type**

2 = 35 mm rail (EN 50022) mount

**No. of poles**

1 = Single phase switch 1 NO

2 = Double phase switch 2 NO

3 = Double phase switch 1 NC + 1 NO

4 = 4 sequence double phase switch 2 NO

6 = 3 sequence double phase switch 2 NO

8 = 4 sequence double phase switch 2 NO

**Contact material**

0 = AgNi standard

4 = AgSnO<sub>2</sub>

**Coil voltage**

see coil specifications

**Coil version**

8 = AC (50/60 Hz)

9 = DC

## TECHNICAL DATA

### INSULATION

DIELECTRIC STRENGTH		
- between supply and contacts	V AC	3,500
- between open contacts	V AC	2,000
- between adjacent contacts	V AC	2,000

### OTHER DATA

**20.21**

**20.22, 20.23, 20.24, 20.26, 20.28**

POWER LOST TO THE ENVIRONMENT		20.21		20.22, 20.23, 20.24, 20.26, 20.28	
- with rated current	W	1.3		2.6	
MAX WIRE SIZE	mm <sup>2</sup>	<b>COIL CLAMPS</b>		<b>CONTACT CLAMPS</b>	
		solid cable	stranded cable	solid cable	stranded cable
		1x4 / 2x2.5	1x2.5 / 2x2.5	1x6 / 2x4	1x4 / 2x2.5
	AWG	1x12 / 2x14	1x14 / 2x14	1x10 / 2x12	1x12 / 2x14
SCREW TORQUE	Nm	0.8		0.8	

If the coil is operated for a prolonged period of time, adequate ventilation of the relays must be provided, for example leaving a gap of about 9mm between pairs of relays.

## COIL SPECIFICATIONS

### AC VERSION DATA

Nominal voltage U <sub>N</sub>	Coil code	Operating range		Resistance R	Consumption I at U <sub>N</sub> (50Hz)
		U <sub>min</sub>	U <sub>max</sub>		
V		V	V	Ω	mA
8	8.008	6.8	8.8	4	800
12	8.012	10.2	13.2	7.5	550
24	8.024	20.4	26.4	27	275
48	8.048	40.8	52.8	106	150
110	8.110	93.5	121	590	64
120	8.120	102	132	680	54
230	8.230	195.5	253	2,500	28
240	8.240	204	264	2,700	27.5

### DC VERSION DATA

Nominal voltage U <sub>N</sub>	Coil code	Operating range		Resistance R	Consumption I at U <sub>N</sub>
		U <sub>min</sub>	U <sub>max</sub>		
V		V	V	Ω	mA
12	9.012	10.8	13.2	27	440
24	9.024	21.6	26.4	105	230
48	9.048	43.2	52.8	440	110
110	9.110	99	121	2,330	47

TYPE	Number of steps	SEQUENCES			
		1	2	3	4
20.21	2				
20.22	2				
20.23	2				
20.24	4				
20.26	3				
20.28	4				

## ACCESSORIES

### MODULE FOR ILLUMINATED PUSH-BUTTONS

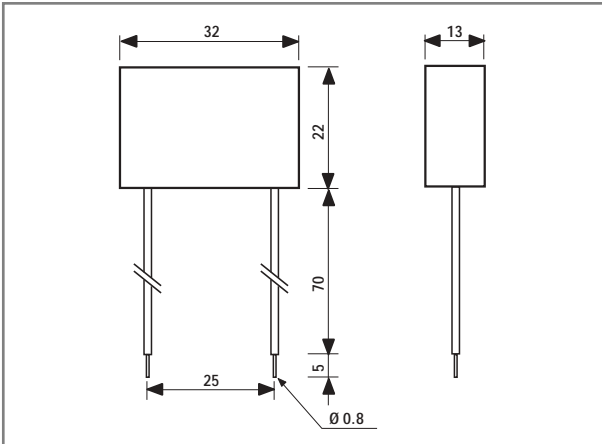

#### Type 026.00

Sealed version, 7.5 cm insulated and flexible terminals.

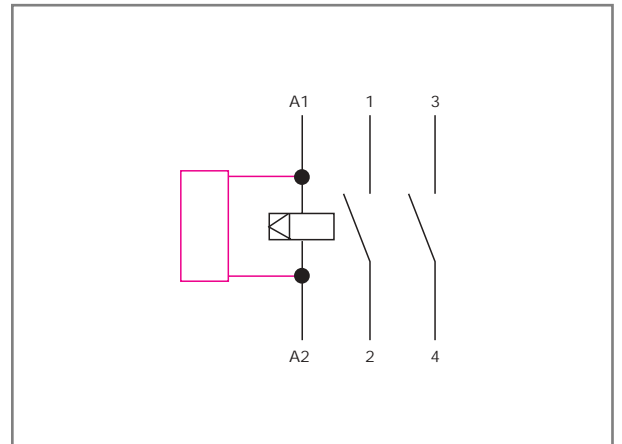

#### Example of wiring diagram of type 026.00

This module is necessary if using up to a maximum of 15 illuminated pushbuttons (1.5 mA max, 230 V AC) in the switching input circuit. It must be connected in parallel to the coil of the relay (see diagram).

## ACCESSORIES

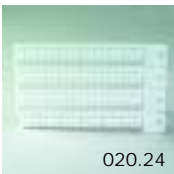

020.24

Sheet of marker tags (24 tags)

020.24

- One module (17.4mm) wide
- Test button
- Identification label
- AC and DC coils
- 35 mm rail (EN 50022) mount

**22.21**
**22.22**

- Single phase switch 1 NO  
- 35 mm rail mount

- Double phase switch 2 NO  
- 35 mm rail mount

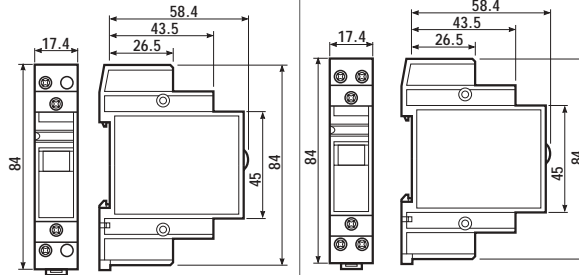
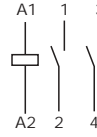







<b>Contact specifications</b>			
Contact configuration		1 NO	2 NO
Rated current/Max. peak current	A	20/30	20/30
Rated voltage/Max. switching voltage	V AC	250/400	250/400
Rated load in AC1	VA	5,000	5,000
Rated load in AC15 (230 VAC)	VA	1,000	1,000
Single phase motor rating (230 VAC)	kW	—	—
Breaking capacity: 30/110/220 V	A	20/0.3/0.12	20/0.3/0.12
Minimum switching load	mW(V/mA)	1,000 (10/10)	1,000 (10/10)
Standard contact material		AgNi	AgNi
<b>Coil specifications</b>			
Nominal voltage	V AC (50/60Hz)	8 - 12 - 24 - 48 - 110 - 120 - 230 - 240	
	V DC	12 - 24 - 48 - 110	12 - 24 - 48 - 110
Rated power AC/DC	VA (50Hz)/W	2.3/1.25	2.3/1.25
Operating range	AC (50Hz)	(0.85...1.1)U <sub>N</sub>	
	DC	(0.9...1.1)U <sub>N</sub>	
<b>Technical data</b>			
Mechanical life	cycles	500 · 10 <sup>3</sup>	500 · 10 <sup>3</sup>
Electrical life at rated load in AC1	cycles	50 · 10 <sup>3</sup>	50 · 10 <sup>3</sup>
Maximum impulse duration		continuous	continuous
Insulation between coil and contacts (1.2/50µs)	kV	4	4
Ambient temperature range	°C	-40...+40	-40...+40
Protection category		IP 20	IP 20
<b>Approvals:</b> (according to type)		<b>CE</b>	

- One module (17.4mm) wide
- Test button
- Identification label
- AC and DC coils
- 35 mm rail (EN 50022) mount

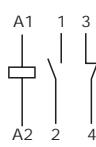
## 22.23

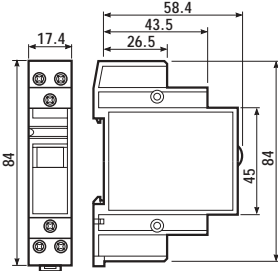
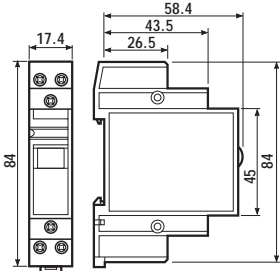
## 22.24

	
<ul style="list-style-type: none"> <li>- Double phase switch</li> <li>1 NO + 1 NC</li> <li>- 35 mm rail mount</li> </ul>	<ul style="list-style-type: none"> <li>- Double phase switch 2 NC</li> <li>- 35 mm rail mount</li> </ul>
	
	

Contact specifications			
Contact configuration		1 NO + 1 NC	2 NC
Rated current/Max. peak current	A	20/30	20/30
Rated voltage/Max. switching voltage	V AC	250/400	250/400
Rated load in AC1	VA	5,000	5,000
Rated load in AC15 (230 VAC)	VA	1,000	1,000
Single phase motor rating (230 VAC)	kW	—	—
Breaking capacity: 30/110/220 V	A	20/0.3/0.12	20/0.3/0.12
Minimum switching load	mW(V/mA)	1,000 (10/10)	1,000 (10/10)
Standard contact material		AgNi	AgNi
Coil specifications			
Nominal voltage	V AC (50/60Hz)	8 · 12 · 24 · 48 · 110 · 120 · 230 · 240	
	V DC	12 · 24 · 48 · 110	12 · 24 · 48 · 110
Rated power AC/DC	VA (50Hz)/W	2.3/1.25	2.3/1.25
Operating range	AC (50Hz)	(0.85...1.1)U <sub>N</sub>	(0.85...1.1)U <sub>N</sub>
	DC	(0.9...1.1)U <sub>N</sub>	(0.9...1.1)U <sub>N</sub>
Technical data			
Mechanical life	cycles	500 · 10 <sup>3</sup>	500 · 10 <sup>3</sup>
Electrical life at rated load in AC1	cycles	50 · 10 <sup>3</sup>	50 · 10 <sup>3</sup>
Maximum impulse duration		continuous	continuous
Insulation between coil and contacts (1.2/50µs)	kV	4	4
Ambient temperature range	°C	-40...+40	-40...+40
Protection category		IP 20	IP 20
<b>Approvals:</b> (according to type)			

## ORDERING INFORMATION

Example: a 22 series 35 mm rail mount relay with 1 NO - 20 A contacts, with coil rated at 24 V DC, contact material AgSnO<sub>2</sub>.

**2 2 . 2 1 . 9 . 0 2 4 . 4 0 0 0**

**Series**

**Type**

2 = 35 mm rail (EN 50022) mount

**No. of poles**

1 = 1 NO  
2 = 2 NO  
3 = 1 NO  
4 = 2 NC

**Contact material**

4 = AgSnO<sub>2</sub>

**Coil voltage**

see coil specifications

**Coil version**

8 = AC (50/60 Hz)  
9 = DC

## TECHNICAL DATA

### CONTACT SPECIFICATIONS

NOMINAL RATE LAMPS		
- incandescence (230V)	W	1,000
- compensated fluorescent (230V)	W	360

### INSULATION

DIELECTRIC STRENGTH		
- between supply and contacts	V AC	3,500
- between open contacts	V AC	2,000
- between adjacent contacts	V AC	2,000

### OTHER DATA

**22.21**

**22.22, 22.23, 22.24**

POWER LOST TO THE ENVIRONMENT					
- without contact current	W	1.2		1.2	
- with rated current	W	3.2		5.2	
MAX WIRE SIZE		<b>COIL CLAMPS</b>		<b>CONTACT CLAMPS</b>	
		solid cable	stranded cable	solid cable	stranded cable
	mm <sup>2</sup>	1x4 / 2x2.5	1x2.5 / 2x2.5	1x6 / 2x6	1x6 / 2x4
	AWG	1x12 / 2x14	1x14 / 2x14	1x10 / 2x10	1x10 / 2x12
SCREW TORQUE	Nm	0.8		0.8	

If the coil is operated for a prolonged period of time, adequate ventilation of the relays must be provided, for example leaving a gap of about 9mm between pairs of relays.

## COIL SPECIFICATIONS

### AC VERSION DATA

Nominal voltage U <sub>N</sub> V	Coil code	Operating range		Resistance R Ω	Consumption I at U <sub>N</sub> (50Hz) mA
		U <sub>min</sub> V	U <sub>max</sub> V		
8	8.008	6.8	8.8	6.5	360
12	8.012	10.2	13.2	13.5	245
24	8.024	20.4	26.4	41	135
48	8.048	40.8	52.8	186	68
110	8.110	93.5	121	970	26
120	8.120	102	132	1,380	24
230	8.230	195.5	253	4,200	12.5
240	8.240	204	264	4,400	12

### DC VERSION DATA

Nominal voltage U <sub>N</sub> V	Coil code	Operating range		Resistance R Ω	Consumption I at U <sub>N</sub> mA
		U <sub>min</sub> V	U <sub>max</sub> V		
12	9.012	10.8	13.2	115	104.3
24	9.024	21.6	26.4	460	52.2
48	9.048	43.2	52.8	1,850	25.9
110	9.110	99	121	9,700	11.3

## 22 ACCESSORIES

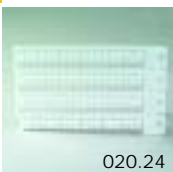

020.24

Sheet of marker tags (24 tags)

020.24





- Single phase switch 1 NO    - Double phase switch 2 NO    - 1 NC + 1 NO

<b>Contact specifications</b>				
Number of contacts		1 NO	2 NO	1 NC + 1 NO
Rated current/Max. peak current	A	10/20	10/20	10/20
Rated voltage/Max. switching voltage	V AC	250/400	250/400	250/400
Rated load in AC1	VA	2,500	2,500	2,500
Rated load in AC15 (230 VAC)	VA	500	500	500
Nominal lamp rating: incandescence (230V)	W	800	800	800
compensated fluorescent (230V)	W	360	360	360
uncompensated fluorescent (230V)	W	500	500	500
halogens (230V)	W	800	800	800
Minimum switching load	mW(V/mA)	1,000 (10/10)	1,000 (10/10)	1,000 (10/10)
Standard contact material		AgNi	AgNi	AgNi
<b>Coil specifications</b>				
Nominal voltage	V AC (50Hz)	12 · 24 · 48 · 110 · 230	12 · 24 · 48 · 110 · 230	12 · 24 · 48 · 110 · 230
	V DC	—	—	—
Rated power AC/DC	VA (50Hz)/W	4.5/—	4.5/—	4.5/—
Operating range	AC (50Hz)	(0.8...1.1)U <sub>N</sub>	(0.8...1.1)U <sub>N</sub>	(0.8...1.1)U <sub>N</sub>
	DC	—	—	—
<b>Technical data</b>				
Mechanical life	cycles	300 · 10 <sup>3</sup>	300 · 10 <sup>3</sup>	300 · 10 <sup>3</sup>
Electrical life at rated load in AC1	cycles	100 · 10 <sup>3</sup>	100 · 10 <sup>3</sup>	100 · 10 <sup>3</sup>
Maximum impulse duration		1 h (according to EN60669)	1 h (according to EN60669)	1 h (according to EN60669)
Insulation between coil and contacts (1.2/50μs)	kV	4	4	4
Ambient temperature range	°C	-40...+40	-40...+40	-40...+40
Protection category		IP 20	IP 20	IP 20
<b>Approvals:</b> (according to type)				

## ORDERING INFORMATION

Example: a 26 series screw terminal mount relay with double phase switch 2 NO - 10 A contacts, with coil rated at 12 V AC.

**2 6 . 0 2 . 8 . 0 1 2 . 0 0 0 0**

**Series**

**Type**

0 = Screw terminal

**No. of poles**

- 1 = Single phase switch 1 NO
- 2 = Double phase switch 2 NO
- 3 = Double phase switch 1 NO + 1 NC
- 4 = 4 sequence double phase switch 2 NO
- 6 = 3 sequence double phase switch 2 NO
- 8 = 4 sequence double phase switch 2 NO

**Coil voltage**

see coil specifications

**Coil version**

8 = AC (50 Hz)

## TECHNICAL DATA

### INSULATION

<b>DIELECTRIC STRENGTH</b>		
- between supply and contacts V AC		3,500
- between open contacts V AC		2,000
- between adjacent contacts V AC		2,000

### OTHER DATA

**26.01**

**26.02, 26.03, 26.04, 26.06, 26.08**

<b>POWER LOST TO THE ENVIRONMENT</b>					
- with rated current W		0.9		1.8	
<b>MAX WIRE SIZE</b>		solid cable	stranded cable	solid cable	stranded cable
	mm <sup>2</sup>	1x4 / 2x2.5	1x2.5 / 2x2.5	1x4 / 2x2.5	1x2.5 / 2x2.5
	AWG	1x12 / 2x14	1x14 / 2x14	1x12 / 2x14	1x14 / 2x14
<b>SCREW TORQUE</b>	Nm	0.8		0.8	

## COIL SPECIFICATIONS

### AC VERSION DATA

Nominal voltage $U_N$ V	Coil code	Operating range		Resistance R	Consumption I at $U_N$ (50Hz) mA
		$U_{min}$ V	$U_{max}$ V		
12	<b>8.012</b>	9.6	13.2	17	370
24	<b>8.024</b>	19.2	26.4	70	180
48	<b>8.048</b>	38.4	52.8	290	90
110	<b>8.110</b>	88	121	1,500	40
230	<b>8.230</b>	184	253	6,250	20

TYPE	Number of steps	SEQUENCES			
		1	2	3	4
26.01	2				
26.02	2				
26.03	2				
26.04	4				
26.06	3				
26.08	4				

## ACCESSORIES

### 12-24 V DC CONTROL APPLICATIONS

**Type: 026.9.012**

NOMINAL VOLTAGE: 12 V DC  
 MAX TEMPERATURE: + 40 °C  
 OPERATING RANGE: (0.9...1.1)U<sub>N</sub>

**Type: 026.9.024**

NOMINAL VOLTAGE: 24 V DC  
 MAX TEMPERATURE: + 40 °C  
 OPERATING RANGE: (0.9...1.1)U<sub>N</sub>

24 V AC

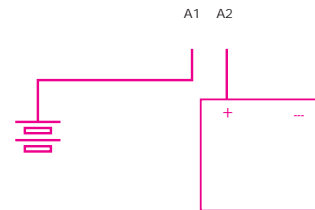

**Example of wiring for 24 V DC control application.**

### MODULE FOR ILLUMINATED PUSH-BUTTONS

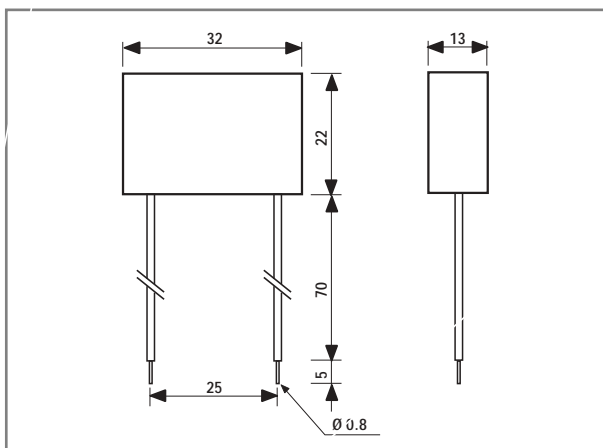

**Type 026.00**

Sealed version, 7.5 cm insulated and flexible terminals.

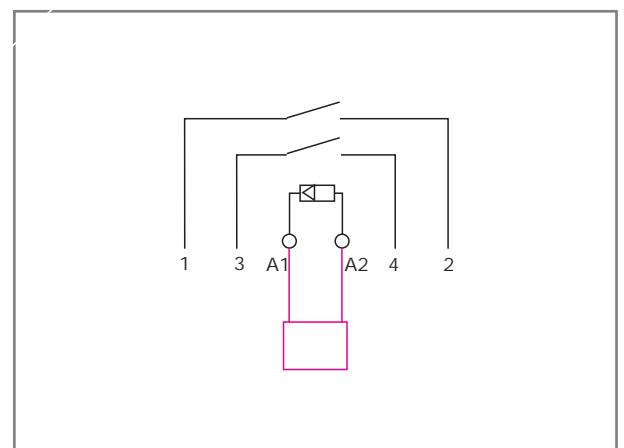

**Example of wiring diagram of type 026.00**

This module is necessary if using up to a maximum of 15 illuminated pushbuttons (1.5 mA max, 230 V AC) in the switching input circuit. It must be connected in parallel to the coil of the relay (see diagram).

- Screw terminal connect
- AC coil
- Panel mount



Contact specifications				
Number of contacts				2
Rated current/Max. peak current				10/20
Rated voltage/Max. switching voltage	V / V			230/230
Rated load in AC1	VA			2,300
Rated load in AC15 (230 VAC)	VA			500
Nominal lamp rating: incandescence (230V)	W	1000		1000
	compensated fluorescent (230V)	W	360	360
	uncompensated fluorescent (230V)	W	500	500
	halogens (230V)	W	800	800
Minimum switching load	mW(V/mA)	1,000 (10/10)		1,000 (10/10)
Standard contact material		AgNi		AgNi
Coil specifications				
Nominal voltage	V AC (50Hz)	230		230
	V DC	—		—
Rated power AC/DC	VA (50Hz)/W	4/—		4/—
Operating range	AC (50Hz)	(0.8...1.1)U <sub>N</sub>		(0.8...1.1)U <sub>N</sub>
	DC	—		—
Technical data				
Mechanical life	cycles	300 · 10 <sup>3</sup>		300 · 10 <sup>3</sup>
Electrical life at rated load in AC1	cycles	100 · 10 <sup>3</sup>		100 · 10 <sup>3</sup>
Maximum impulse duration		1 h (according to EN60669)		1 h (according to EN60669)
Insulation between coil and contacts (1.2/50µs)	kV	4		4
Ambient temperature range	°C	-40...+40		-40...+40
Protection category		IP 20		IP 20
<b>Approvals:</b> (according to type)				

## ORDERING INFORMATION

Example: a 27 series clamp terminal mount relay with single phase switch 1 NO - 10 A contacts, with coil rated at 230 V AC.

**2 7 . 0 1 . 8 . 2 3 0 . 0 0 0 0**

**Series**

**Type**

0 = Clamp terminal

**No. of poles**

1 = Single phase switch 1 NO

5 = 4 sequence double phase switch 2 NO

6 = 3 sequence double phase switch 2 NO

**Coil voltage**

see coil specifications

**Coil version**

8 = AC (50 Hz)

## TECHNICAL DATA

### INSULATION

DIELECTRIC STRENGTH - between open contacts	V AC	2,000
--	------	-------

### OTHER DATA

		27.01	27.05, 27.06		
POWER LOST TO THE ENVIRONMENT - with rated current	W	0.9	1.8		
MAX WIRE SIZE		solid cable	stranded cable	solid cable	stranded cable
	mm <sup>2</sup>	2x2.5	1x4 / 2x2.5	2x2.5	1x4 / 2x2.5
	AWG	2x14	1x12 / 2x14	2x14	1x12 / 2x14
SCREW TORQUE	Nm	0.8	0.8		

## COIL SPECIFICATIONS

### AC VERSION DATA

Nominal voltage $U_N$ V	Coil code 8.230	Operating range		Resistance R	Consumption I at $U_N$ (50Hz) mA
		$U_{min}$ V	$U_{max}$ V		
230	8.230	184	253	6500	17.5

Type	Number of steps	Sequences			
		1	2	3	4
27.01	2				
27.05	4				
27.06	3				

## ACCESSORIES

### MODULE FOR ILLUMINATED PUSH-BUTTONS

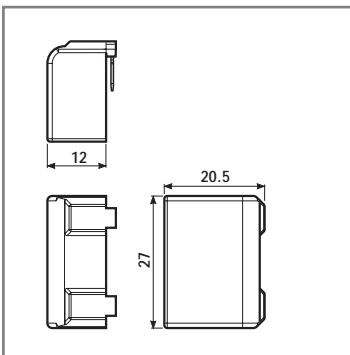

#### Type 027.00

This module is necessary if using up to a maximum of 15 illuminated push-buttons (1 mA max, 230 V AC) in the switching input circuit.

It must be plugged directly into the relay.

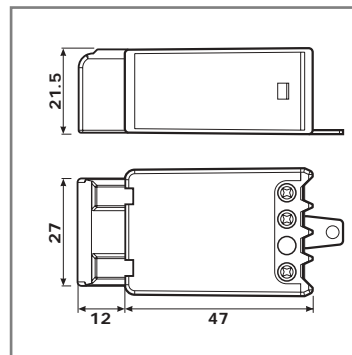

27 series relay with 027.00 module.



## REFERENCE STANDARDS AND VALUES

Unless expressly indicated otherwise, the products shown in this catalogue are designed and manufactured according to the requirements of the following European and International Standards:

- EN 61810-1, EN 61810-5, IEC 61810-7, EN 60255-23 for all-or-nothing (elementary) relays
- EN 61812-1 for timers
- EN 60669-1 and EN 60669-2-2 for electromechanical step relays
- EN 60669-1, EN 60669-2-1 and EN 60669-2-3 for electronic step relays and staircase switches
- EN 60065 for light-dependent relays

Other standards, used as reference for double insulation, are:

- VDE 0106 as basic standard
- EN 60335 (VDE 0700) for domestic appliances, prescribing 8mm creepage and clearance between coil and contacts
- EN 50178 (VDE 0160) for industrial appliances, prescribing 5.5 mm clearance and 6.4...8 mm creepage between coil and contacts

According to EN 61810-1, all technical data is specified under standard conditions of 23°C ambient temperature, 96 kPa pressure, 50% humidity, clean air and 50 Hz frequency. The tolerance for coil resistance, nominal absorption and rated power values is  $\pm 10\%$ .

## WORKING CONDITIONS

- Unless expressly indicated otherwise, all relays are suitable for 100% Duty Cycle and all the AC coil relays are suitable for 50 and 60 Hz frequency.
- Environmental conditions causing condensation or ice formation in the relay are not permitted.
- Overvoltage protection (varistor for AC, diode for DC) is recommended in parallel with the coil for nominal voltages  $\geq 110$  V for the relays of 40, 41, 44 series.
- When relay coils are controlled via a proximity switch, or via cables having length  $> 10$ m, the use of a "residual current bypass" module in parallel with the coil is recommended.

## GUIDELINES FOR AUTOMATIC FLOW SOLDER PROCESSES

In general, an automatic flow solder process consists of the following stages:

**RELAY MOUNTING** - Ensure that the relay terminals are straight and enter the PC board perpendicular to the PC board. For each relay, the catalogue illustrates the necessary PC board pattern (copper side view).

**FLUX APPLICATION** - This is a particularly delicate process. If the relay is not sealed, flux may penetrate the relay due to capillary forces changing its performance and functionality.

Whether using foam or spray fluxing methods, ensure that flux is applied sparingly and evenly and does not flood through to the component side of the PC board.

By following the above precautions, and assuming the use of alcohol or water based fluxes, it is possible to satisfactorily use relays with protection category RT II.

**PREHEATING** - Set the preheat time and heat to just achieve the effective evaporation of the flux, taking care not to exceed a component side temperature of 100°C (212°F).

**SOLDERING** - Set the height of the molten solder wave such that the PC board is not flooded with solder.

Ensure the solder temperature and time are kept to 250°C (482°F) and 3 seconds maximum.

**CLEANING** - The use of modern "no-clean" flux avoids the necessity of washing the PC board. In special cases where the PC board must be washed the use of wash-tight relays (option 0001 - RT III) is strongly recommended. Even so, avoid washing the relay itself, particularly with aggressive solvents or in cycles using low temperature water, as this may cause thermal shock to the PC board components.

## TERMINOLOGY & DEFINITIONS

All the following terms indicated in the catalogue are commonly used in technical language. However, occasionally, National European or International Standards may prescribe the use of different terms, in which case this will be mentioned in the appropriate descriptions that follow.

## CONTACT SPECIFICATIONS

### CONTACT CONFIGURATION:

Symbol	Configuration	EU	D	GB	USA
	Make contact (Normally Open)	NO	S	A	SPST-NO DPST-NO nPST-NO
	Break contact (Normally Closed)	NC	Ö	B	SPST-NC DPST-NC nPST-NC
	Changeover	CO	W	C	SPDT DPDT nPDT

n = number of poles (3,4,...)

### TERMINAL MARKING

The European Standard EN 50005 recommends the following numbering for the marking of relay terminals:

- .1 for common contact terminals (e.g. 11, 21, 31...)
- .2 for NC contact terminals (e.g. 12, 22, 32...)
- .4 for NO contact terminals (e.g. 14, 24, 34...)
- A1 and A2 for coil terminals

For delayed contacts of timers the numbering will be:

- .5 for common contact terminals (e.g. 15, 25,...)
- .6 for NC contact terminals (e.g. 16, 26, ...)
- .8 for NO contact terminals (e.g. 18, 28,...)

IEC 67 and American standards prescribe:

- progressive numbering for terminals (1,2,3,...13,14,..)
- sometimes A and B for coil terminals.

**RATED CURRENT** - The limiting continuous current, is the highest current that a contact can continuously carry within the prescribed temperature limits. It also coincides with the limiting cycling capacity, i.e. the maximum current that a contact is capable of making and breaking under specified conditions.

**MAXIMUM PEAK CURRENT** - The highest value of inrush current ( $\leq 0.5$  seconds) that a contact can make and cycle (duty cycle  $\leq 0.1$ ) without undergoing any permanent degradation of its characteristics due to generated heat. It also coincides with the limiting making capacity

**MAXIMUM BLOCKING VOLTAGE (Solid State Relay)** - The maximum level of output voltage at which the output circuit will not be destroyed.

**RATED VOLTAGE** - The line-to-neutral voltage (derived from nominal voltages of contact loads) used for insulation co-ordination.

**MAXIMUM SWITCHING VOLTAGE** - The highest voltage level (including tolerances) that the contacts are able to switch according to rated voltage.

**RATED LOAD IN AC1** - The maximum AC resistive switching power (in VA) that a contact can make, carry and break repeatedly, according to utilisation category AC1, EN 60947-4-1 (see Table 1). It is the product of rated current and rated voltage. It is used as the reference load for electrical life tests.

**RATED LOAD IN AC15** - The maximum AC inductive switching power (in VA) that a contact can make, carry and break repeatedly, according to utilisation category AC15, EN 60947-5-1 (see Table 1).

**SINGLE PHASE MOTOR RATING** - The nominal value of motor power that a relay can switch according to EN 60947-1, UL 508 and CSA 22.2 n. 14 \* The figures are given in kW; the horsepower rating can be calculated by multiplying that value by 1.34 (ie. 0.37 kW = 0.5 HP). If reversing motor direction, always allow an intermediate break > 300ms, otherwise an excessive inrush peak current (caused from change of polarity of motor capacitor) may occur, causing contact welding.

**RATED LAMPS LOAD** - Maximum incandescent and fluorescent lamp ratings for 230 V AC supply voltage. Fluorescent lamps compensated to  $\cos \phi \geq 0.9$ .

**BREAKING CAPACITY IN DC1** - The maximum value of DC resistive current that contacts can switch, depending on the value of the load voltage (see table 1).

**MINIMUM SWITCHING LOAD** - The minimum values of power, voltage and current that a contact can reliably switch. For example, if minimum values are 300mW, 5V/5mA:

- with 5V the current must be at least 60mA;
- with 24V the current must be at least 12.5mA;
- with 5 mA the voltage must be at least 60 V.

For gold contact variants, loads no less than 50mW, 5V/2mA are suggested.

With 2 gold contacts in parallel, it is possible to switch 1mW, 0,1V/1mA.



**ELECTRICAL LIFE TEST** - An AC resistive load test (AC1category) conducted with relay coil (both AC and DC) supplied at rated voltage. Load applied between all movable and NO contacts but without any load on the NC contacts, and vice-versa. These load life values are valid for relays with standard contact material.

Switching frequency: **All-or-nothing relays:** coil 900 cycles/h - contact 900 cycles/h (2s ON - 2s OFF)  
**Step relays:** coil 900 cycles/h - contact 450 cycles/h (4s ON - 4s OFF)

**LOAD REDUCTION FACTOR VERSUS COS  $\phi$**  - For AC inductive loads (such as solenoids, contactors coils, etc.) the reduction factor corresponding to  $\cos \phi$  shall be multiplied by the rated current in order to define the maximum allowed current It is not valid for electric motors or fluorescent lamps.

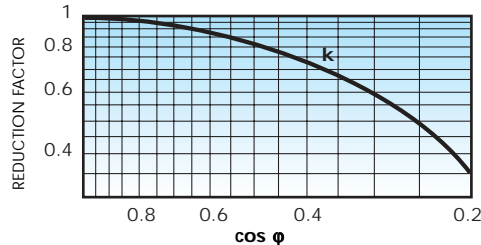

**TABLE 1 - Utilisation categories according to EN60947-4-1 and EN 60947-5-1**

Load Category	Supply type	Application
<b>AC 1</b>	AC single-phase AC three-phase	Resistive or slightly Inductive AC loads.
<b>AC 3</b>	AC three-phase	Starting and stopping of Squirrel-cage motors. Reversing direction of rotation only after stopping motor.
<b>AC 4</b>	AC three-phase	Starting, Stopping and Reversing direction of rotation of Squirrel cage motors. Jogging (Inching). Regenerative braking (Plugging).
<b>DC 1</b>	DC	Resistive loads or slightly inductive DC loads.*
<b>AC 14</b>	AC single-phase	Control of small electromagnetic loads (<72 VA), power contactors, magnetic solenoid valves, and electromagnets.
<b>AC 15</b>	AC single-phase	Control of small electromagnetic loads (>72 VA), power contactors, magnetic solenoid valves, and electromagnets.
<b>DC 13</b>	DC	Control of electromagnetic loads, power contactors, magnetic solenoid valves, and electromagnets

\* The switching voltage at the same current can be doubled by wiring 2 contacts in series.

**CONTACT RESISTANCE** - Measured, according to contact category (Table 2), at the external terminals of the relay. It is a statistical value, not reproducible. It hasn't any effect on relay reliability on most application. The typical value, measured with 24 V 100 mA, is 50 m $\Omega$ .

**TABLE 2 - Contact categories according to EN60255-23**

The effectiveness with which a relay contact can make an electrical circuit depends on several factors, such as the material used for the contact, its' exposure to environmental pollution and its' design etc.. Therefore, for reliable operation, it is necessary to specify a contact Application Category that will define a particular relay's switching capability in terms of maximum and minimum limits for contact voltage and current. The appropriate Application Category will also define the voltage and current levels used to measure the contact resistance. All Finder relays are category 3, with the exception of 30 series, which is category 2.

Application category	Voltage (V)	Current (A)	Contact Resistance Measurement (IEC 61810-7)	
0	$U < 0,03$	$I < 0.01$	> 30 mV	10 mA
1	$0,03 < U < 60$	$0,01 < I < 0,1$	100 mV	10 mA
2	$5 < U < 250$	$0,1 < I < 1$	24 V	100 mA
<b>3</b>	<b><math>5 &lt; U &lt; 600</math></b>	<b><math>0,1 &lt; I &lt; 100</math></b>	<b>24 V</b>	<b>1000 mA</b>

**TABLE 3 - Contact materials characteristics**

Material	Property	Typical application*
AgNi + Au (Silver Nickel Gold plated)	<ul style="list-style-type: none"> <li>- Silver-nickel base with a galvanic hard gold plating of 5 <math>\mu</math>m typical thickness</li> <li>- Gold is not attacked by industrial atmospheres</li> <li>- With small loads, contact resistance is lower and more consistent compared to other materials.</li> </ul> <p><b>NOTE:</b> 5 <math>\mu</math>m hard gold plating is completely different from 0.2 <math>\mu</math>m gold flashing, which allows only protection in storing, but no better performance in use.</p>	<p>Wide range applications:</p> <ul style="list-style-type: none"> <li>- <b>Small load range</b> (where gold plating erodes very little) from 50 mW (5V 2mA) up to 1.5 W/24 V (resistive load).</li> <li>- <b>Middle load range</b> where gold plating erodes after several operations and the property of basic AgNi becomes dominant.</li> </ul> <p><b>NOTE:</b> for switching lower loads, typically 1mW (0.1V 1mA), (for example in measuring instruments), it is recommended to connect 2 contacts in parallel.</p>
AgNi (Silver Nickel)	<ul style="list-style-type: none"> <li>- Standard contact material for most relay applications.</li> <li>- High wear resistance</li> <li>- Medium resistance to welding</li> </ul>	<ul style="list-style-type: none"> <li>- Resistive and slightly inductive loads</li> <li>- Rated current up to 12 A</li> <li>- Inrush current up to 25 A</li> </ul>
AgCdO (Silver Cadmium Oxide)	<ul style="list-style-type: none"> <li>- High wear resistance with higher AC loads</li> <li>- Good resistance to welding</li> </ul>	<ul style="list-style-type: none"> <li>- Inductive and motor loads</li> <li>- Rated current up to 30 A</li> <li>- Inrush current up to 50 A</li> </ul>
AgSnO <sub>2</sub> (Silver Tin Oxide)	<ul style="list-style-type: none"> <li>- Excellent resistance to welding</li> <li>- Low material transfer in DC loads</li> </ul>	<ul style="list-style-type: none"> <li>- Lamp and capacitive loads</li> <li>- Very high Inrush current (up to 120 A) loads</li> </ul>

\* It is necessary to refer to the maximum current values specified in the catalogue for each relay.

## COIL (or INPUT or SUPPLY) SPECIFICATIONS

**NOMINAL VOLTAGE** - The nominal value of coil (or input or supply) voltage for which the relay has been designed, and for which operation is intended. The operating and use characteristics are referred to the rated voltage.

**RATED POWER** - The DC power value (W) or the apparent AC power value (VA with closed armature) which is absorbed by the coil at 23°C and at rated voltage. It is a short-time value (not steady-state).

**OPERATING RANGE** - The range of input voltage, in nominal voltage applications, in which the relay works in the whole range of ambient temperatures, according to operating class:

- class 1: 0.8...1.1 U<sub>N</sub>
- class 2: 0.85...1.1 U<sub>N</sub>

In application where the coil voltage doesn't meet the tolerances of nominal voltage, the diagrams "R" shows the relation of maximum coil voltage permitted and pick-up voltage (without pre-energisation) versus ambient temperature.

### ENERGIZATION VOLTAGE

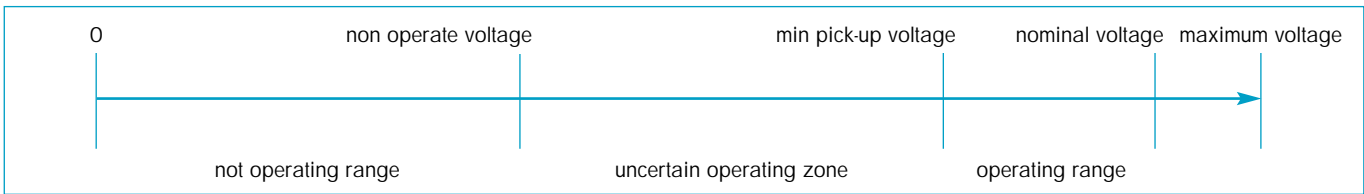

### DE-ENERGIZATION VOLTAGE

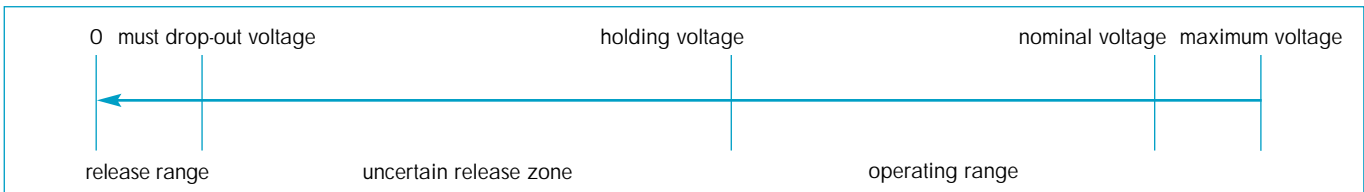

**NON-OPERATE VOLTAGE** - The value of input voltage at which the relay will not operate (not specified in the catalogue).

**MINIMUM PICK-UP VOLTAGE (Operate voltage)** - The lowest value of applied voltage at which the relay will operate.

**MAXIMUM VOLTAGE** - The highest applied voltage that the relay can continuously withstand, dependent on ambient temperature (see "R" diagrams).

**HOLDING VOLTAGE (Non-release voltage)** - The lowest value of coil voltage at which the relay (which has previously been energised with a voltage within the operating range) will not drop-out.

**MUST DROP-OUT VOLTAGE (Release voltage)** - The value of coil voltage at which the relay (which had previously been energised with a voltage within the operating range) will definitely drop-out.

**RESISTANCE** - The average value of the coil resistance under the standard prescribed condition of 23°C ambient.

**RATED COIL CONSUMPTION** - The average value of coil current, when energised at nominal voltage.

**CONTROL CURRENT (Solid State Relays)** - The nominal value of current consumption of the input circuit, when supplied at nominal voltage.

**THERMAL TESTS** - Calculation of the coil temperature rise ( $\Delta T$ ) is made by measuring the coil resistance in a controlled temperature oven (not ventilated) until a stable value is reached (no less than 0.5 K variation in 10 minutes).

That is:  $\Delta T = (R_2 - R_1) / R_1 \times (234.5 + t_1) \cdot (t_2 - t_1)$

- where:
- R<sub>1</sub> = initial resistance
  - R<sub>2</sub> = final resistance
  - t<sub>1</sub> = initial temperature
  - t<sub>2</sub> = final temperature

## INSULATION DATA

**INSULATION COORDINATION** (according to EN 61810-5 and IEC 60664-1)

In accordance with to EN 61810-5, the Insulation characteristics achieved by the relay can be described by just two characteristic parameters – the Rated Impulse Voltage and the Degree of Pollution.

To ensure the correct Insulation Coordination between the relay and the application, the equipment designer (relay user) should establish the Rated Impulse Withstand Voltage appropriate to his application, and the Pollution level for the micro environment in which the relay is situated. He should then match (or coordinate) these two figures with the corresponding values given in the appropriate relay data.

To establish the appropriate Pollution degree and Rated impulse withstand voltage refer either to an appropriate Product Standard (which may be mandatory for the particular type of equipment), or consider the tables below. Select the Rated impulse withstand voltage from a knowledge of the Nominal Voltage of the Supply and a knowledge of the Over Voltage Category (as described in IEC60664-1).

Nominal voltage of the supply system (mains) according to IEC 60038		Voltage line-to-neutral (derived from nominal voltages AC or DC, up to and including)	Rated impulse withstand voltage			
V			V			
Three-phase	Single-phase		Overvoltage category			
			I	II	III	IV
	120 to 240	150	800	1500	2500	4000
230/400*		250*	1200*	2200*	3600*	5500*
230/400 277/480		300	1500	2500	4000	6000

\* For existing products the interpolated values apply

Pollution degree	Immediate surroundings conditions
1	No pollution or only dry, non-conductive pollution occurs. The pollution has no influence.
2	Only non-conductive pollution occurs, except that occasionally a temporary conductivity caused by condensation is to be expected.
3	Conductive pollution occurs or dry, non-conductive pollution occurs which becomes conductive due to condensation which is to be expected.
4	The pollution generates persistent conductivity caused by conductive dust or by rain or snow.

Dependent on the product standard, pollution degree 2 and 3 are commonly prescribed for equipment. For example, EN 50178 (electronic for use in power installations) prescribes, under normal circumstances, contamination level 2.

Examples of specification of Rated Impulse Voltage and the Degree of Pollution :

**4 kV/3** (This relay is designed to withstand a rated impulse voltage of 4 kV and pollution degree 3).

**4 - 2,5 kV/3** (This relay is designed to withstand rated impulse voltages of 4 kV and 2.5 kV and pollution degree 3).

If only one rated impulse voltage is given, the value refers to all electrical circuits against each other and against the accessible surfaces. If two values are indicated for the rated impulse voltage, the first value refers to the contacts against each other and against the accessible surfaces as well as other electrical circuits. The second value refers to the coil against accessible surfaces and other electrical circuits.

**DIELECTRIC STRENGTH** - It can be described in terms of an alternating voltage or in terms of a surge (1.2/50  $\mu$ s impulse) voltage. The correspondence between the alternating voltage and surge voltage is listed in IEC 60664-1 Annex A, Table A.1.

For all Finder relays a 100 % test is carried out with a 50 Hz, alternating voltage applied between all contacts and coil, between adjacent contacts and between open contacts. The leakage current must be less than 3 mA.

Type tests are carried out with both alternating voltage and with impulse voltage.

**DIELECTRIC STRENGTH BETWEEN OPEN CONTACTS** - It far exceeds the maximum switching voltage. Typical contact gaps of 0.3 ~ 0.5 mm result in ultimate dielectric strength values of typically 1300 ~ 1550 V (1.2/50  $\mu$ s impulse), but always refer to the relay specification.

**INSULATION GROUP** - The latest way of specifying insulation properties according to the Insulation Coordination replaces the insulation group classification, such as C 250 according to the older VDE 0110 standard.

**SAFE SEPARATION / DOUBLE INSULATION** - Isolation Co-ordination as described earlier ensures the isolation of hazardous voltages from other circuits to a safe engineering level. But importantly, not on the basis that there is any intentional direct personal access to the isolated circuits or, where failure of insulation would present a particularly high risk. (Telecoms and medical applications, are good examples).

For high risk / high integrity applications there is a need for a very special and higher level of physical isolation and integrity between circuits, and this is provided by safe separation and double insulation. The regulations for safe separation establish the conditions which must be met for PELV (protected extra low voltage) or SELV (safety extra low voltage) circuits.

Consider the common case, where the mains voltage of 230 V and a low voltage circuit both appear within a relay; all the following requirements for the relay, including its connections and wiring, must in consequence be met.

- The low voltage and the 230 V must be separated by double or reinforced insulation. This means that between the two electrical circuits must be guaranteed a dielectric strength of 6 kV (1.2/50  $\mu$ s), an air distance of 5.5 mm and, depending on the pollution degree and on material used, an appropriate tracking distance.
- The electrical circuits within the relay must be protected against any possibility of bridging caused, for instance, by a loose metal part. This is achieved by the physical separation of circuits into isolated chambers within the relay.
- The wires connected to the relay must also be physically separated from each other. This normally is achieved using separate cable channels.
- For relays mounted on printed circuit boards the appropriate distance between the tracks connected to low voltage and the tracks connected to other voltages must be achieved.

Although this appears quite complex, with the SELV insulation options offered on some Finder relays, the user only needs to address the two last points. And with the coil and contact connections on opposite sides of the relays and sockets, the separation of connections into different cable channels is greatly facilitated.

## GENERAL TECHNICAL DATA

**CYCLE** - Operate and subsequent release of a relay. Over a cycle the coil is energised and de-energised and the contact will progress from the point at which it makes a circuit, through to breaking the circuit, to the point at which it re-makes the circuit.

**PERIOD** - The time covering one cycle.

**DUTY FACTOR (DF)** - During cyclic operation, DF is the ratio between the energised time and one period. For continuous duty, DF = 1.

**MECHANICAL LIFE** - This test is performed by energising the coils of several relays at 8 cycles per second without any load applied to the contacts. It establishes the ultimate durability of the relay where electrical wear of the contacts is not an issue. The maximum Electrical Life may therefore approach the Mechanical Life where the electrical loading of the contacts is very small.

**ELECTRICAL LIFE** - See in CONTACT SPECIFICATIONS.

**OPERATE TIME** - The maximum operate time of contacts with the coil energised at rated voltage. In the catalogue, it includes the bounce time (see following pattern).

**RELEASE TIME** - The maximum release time of contacts. In the catalogue, it includes the bounce time (see following pattern). It will increase if protection modules are connected in parallel to the coil.

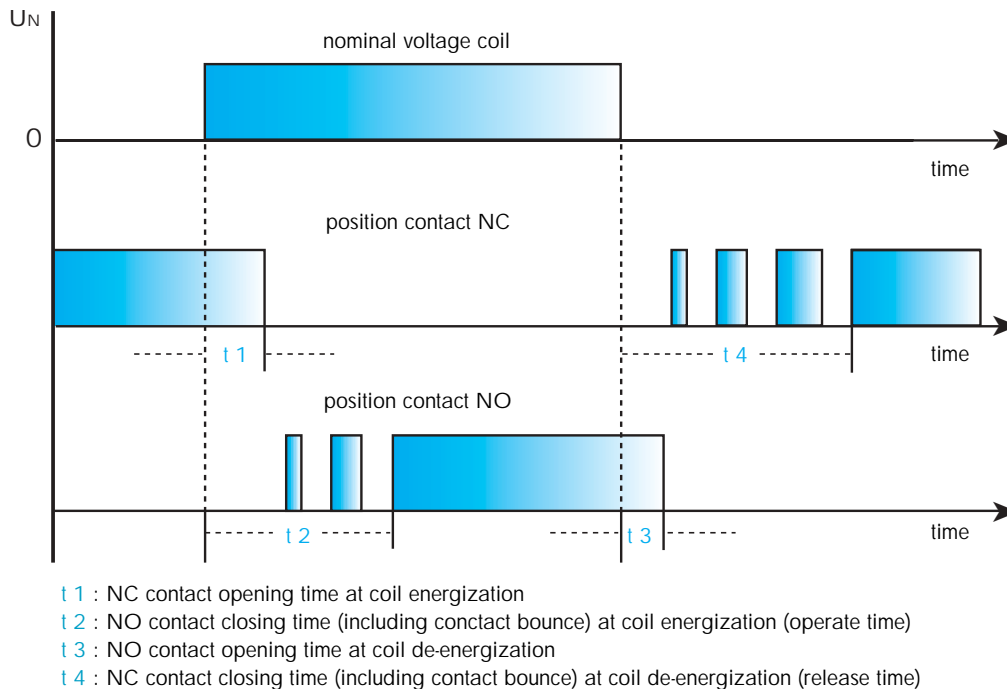

**INSULATION COORDINATION according to EN 61810-5** - See in INSULATION DATA.

**DIELECTRIC STRENGTH BETWEEN OPEN CONTACTS** - See in INSULATION DATA.

**AMBIENT TEMPERATURE RANGE** - The range of temperatures of the immediate area where the relay is located, and for which operation of the relay is guaranteed (under prescribed conditions).

**ENVIRONMENTAL PROTECTION according to IEC 61810-7** - The relay technology categories describe the degree of sealing of the relay case:

Relay technology category	Condition
RT 0 Unenclosed relay	Relay not provided with a protective case.
RT I Dust protected relay	Relay provided with a case which protects its mechanism from dust.
RT II Flux proof relay	Relay capable of being automatically soldered without allowing the migration of solder fluxes beyond the intended areas.
RT III Wash tight relay	Relay capable of being automatically soldered and subsequently undergoing a washing process to remove flux residues without allowing the ingress of flux or washing solvents.
RT IV Sealed relay	Relay provided with a case which has no venting to the outside atmosphere
RT V Hermetically sealed relay	Sealed relay having an enhanced level of sealing.

**PROTECTION CATEGORY OF ENCLOSURES** - according to EN 60529. The first digit is related to the protection against ingress of solid foreign objects into the relay, and also against access to hazardous parts. The second digit relates to the protection against ingress of water. The IP grade is related to normal use, in relay sockets or PC boards. For sockets, IP20 means that the socket is "finger-safe" (VDE0106).

Examples:

IP 00 = Not protected.

IP 20 = Protected against solid foreign objects of 12.5 mm Ø and greater. Not protected against water.

IP 40 = Protected against solid foreign objects of 1 mm Ø and greater. Not protected against water.

IP 50 = Protected against powder (ingress of dust is not totally prevented, but dust shall not penetrate in a quantity to interfere with satisfactory operation of the relay). Not protected against water.

IP 67 = Totally protected against powder (dust-tight) and protected against the effect of temporary immersion in water.

**VIBRATION RESISTANCE** - The maximum acceleration value (measured in  $g = 9.81 \text{ m/s}^2$ ) for frequencies in the range 10-55 Hz which can be applied to the relay in any of the 3 axis, without the opening for more than 10 µs of the NO contact (if the coil is energised) or NC contact (if the coil is not energised). In the energised state, the resistance is usually higher than in non-energised state.

**POWER LOST TO THE ENVIRONMENT** - The value of the power lost from the relay in working conditions (without contact load or at full load) and may be used in the thermal design of panels.

**MOUNTING POSITION** - If not expressly indicated, any mounting position of the relay is permitted.

**RECOMMENDED DISTANCE BETWEEN RELAYS MOUNTED ON PC.Boards** - This is the minimum mounting distance suggested when several relays are mounted on the same PC board. Care shall also be taken that other components mounted on the PC board do not heat the relays.

**TORQUE** - The maximum value of torque that can be used for tightening terminal screws, according to EN 60999, is 0.4 Nm for M2,5 screws, 0.5 Nm for M3 screws, 0.8 Nm for M3, 5 screws, 1.2 Nm for M4 screws.

The test torque is indicated in the catalogue.. Normally a 20% increase of this value is acceptable.

 Both slot-head and cross-head screwdrivers can be used.

**MAX WIRE SIZE** - Maximum cross-section of cables (solid or stranded wire, without ferrules) that can be connected to each terminal. For use with ferrules, the wire cross-section has to be reduced (e.g. from 4 to 2.5 mm<sup>2</sup>, from 2.5 to 1.5 mm<sup>2</sup>, from 1.5 to 1 mm<sup>2</sup>).

For any terminals, a minimum cross-section of 0.2 mm<sup>2</sup> is allowed.

According to EN 60204-1, it is permitted to introduce 2 or more wires into the same terminal. All Finder products are designed in such a way that each terminal can accept 2 or more wires.

**SPECIFIED TIME RANGE** - Range in which it is possible to set timing using the time scales.

**REPEATABILITY** - The difference between the upper and lower limits of a range of values taken from several time measurements of a specified time relay under identical stated conditions. Usually repeatability is indicated as a percentage of the mean value of all measured values.

**RECOVERY TIME** - The time necessary to start the relay again with the defined accuracy after the input energising quantity has been removed.

**MINIMUM CONTROL IMPULSE** - The shortest duration of a control impulse to fulfil and complete the time function.

**SETTING ACCURACY** - The difference between the measured value of the specified time and the reference value set on the scale.

**THRESHOLD SETTING** - For light-dependent relays this is the illumination level (measured in Lux) at which the relay will switch on or off. Pre-set levels and the corresponding range of threshold that can be set using the regulator are indicated in the catalogue.

**DELAY TIME** - For light-dependent relays this is the delay between the change of state in the electronic circuit sensitive to light variation (usually indicated by change of state of an LED) and the switching of the output relay contact.

**CABLE GRIP** - Specifies the range of the external diameter of cables that can be reliably gripped.

**TYPE** - For time switches, this is the type of program (weekly or daily).

**PROGRAMS** - For time switches, this is the number of different types of programs that can be stored.

**MINIMUM INTERVAL SETTING** - For time switches, this it is the minimum time interval that can be programmed.

**BACK-UP POWER** - The time when the switch won't loose neither the programs nor the time.

**MAXIMUM IMPULSE DURATION** - For step relays and staircase switches, this is the maximum command pulse duration permitted.

**MAX NO. OF ILLUMINATED PUSH-BUTTONS** - For step relays and staircase switches, this is the maximum number of illuminated push-buttons (having current absorption < 1mA @ 230 V AC) that can be connected without causing problems. If the push-button consumption is higher than 1 mA, the maximum number of push-buttons allowed is proportionally reduced (ie. 15 push-buttons x 1 mA is equivalent to 10 push-buttons x 1.5 mA).

## EMC (ElectroMagnetic Compatibility) SPECIFICATIONS

TYPE OF TEST	REFERENCE STANDARD
ELECTROSTATIC DISCHARGE	EN 61000-4-2
RADIO-FREQUENCY ELECTROMAGNETIC FIELD (80 ÷ 1000 MHz)	EN 61000-4-3
FAST TRANSIENTS (burst) (5-50 ns, 5 kHz)	EN 61000-4-4
SURGES (1.2/50 µs)	EN 61000-4-5
RADIO-FREQUENCY COMMON MODE DISTURBANCES (0.15 ÷ 80 MHz)	EN 61000-4-6
POWER-FREQUENCY MAGNETIC FIELD (50 Hz)	EN 61000-4-8
RADIATED AND CONDUCTED EMISSION	EN 55011 / 55014 / 55022

In panel installations, the most frequent and, particularly, more dangerous type of electrical disturbances are the following:

- Burst** (fast transients). These are packets of **5/50ns** pulses, having high peak voltage level but low energy since individual pulses are very short - 5 ns rise time ( $5 \times 10^{-9}$  seconds) and 50 ns fall time. They simulate the disturbances that can spread along the cables as a consequence of commutation transients from relays, contactors or motors. Usually they are not destructive, but they can affect the correct working of electronic devices.

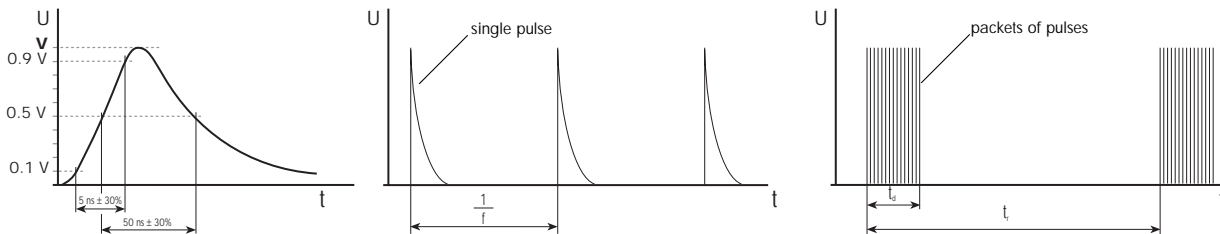

- Surge** (voltage pulses). These are single **1.2/50µs** pulses, with energy much higher than bursts since the duration is considerably longer - 1.2 µs rise time ( $1.2 \times 10^{-6}$  seconds) and 50 µs fall time. For this reason they are very often destructive. The Surge test typically simulates disturbances caused by the propagation of atmospheric electrical storm discharges along electrical lines, but often the switching of power contacts (such as the opening of highly inductive loads) can cause disturbances that are very similar, and equally destructive.

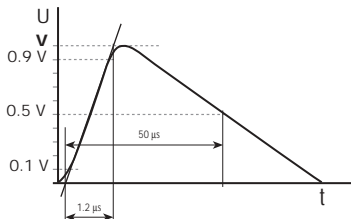

The test levels **V** (peak values of the single pulses) are prescribed in appropriate product standards:

- **EN 61812-1** for electronic timers;
- **EN 60669-2-1** for electronic relays and switches;
- **EN 50082-2** (generic standard for immunity in the industrial environment) for other electronic products for industrial application;
- **EN 50082-1** (generic standard for immunity in the domestic environment) for other electronic products for domestic application;

Finder electronic products are in accordance with European EMC Directives **89/336/EEC** and **93/68/EEC** and indeed, have immunity capabilities often higher than the levels prescribed in the above mentioned standards. Nevertheless, it is not impossible that some working environments may impose levels of disturbances far in excess of the guaranteed levels, such that the product could be immediately destroyed!

It is therefore necessary to consider Finder products as not being indestructible under all circumstances. The user should pay attention to the disturbances in electrical systems and reduce as much as possible these disturbances. For example, employ arc suppression circuits on the contacts of switches, relays or contactors which otherwise might produce over-voltages when opening electrical circuits (particularly highly inductive or DC loads). Attention should also be paid to the placement of components and cables in such a way as to limit disturbances and their propagation.

**EMC rules** - Require that it is the equipment designer who must ensure that the emissions from panels or equipment does not exceed the limits stated in EN 50081-1 (generic standard for emission in the domestic environment) or 50081-2 (generic standard for emission in the industrial environment) or any product specific harmonised EMC standard.

99.01		99.02		99.80	
Sockets	Relays	Sockets	Relays	Sockets	Relays
90.20	60.12	94.02	55.32	94.84.1	55.32, 55.34
90.21	60.13	94.03	55.33		
94.73	55.33	94.04	55.32/34		
94.74	55.34	95.03	40.31		
94.82	55.32	95.05	40.51/52/61		
95.63	40.31		44.52, 44.62		
95.75	40.51/52/61	92.03	62.32, 62.33		
	44.52/62				
96.72	56.32				
96.74	56.34				

FUNCTION/ OPERATING RANGE	CODE	CODE	CODE
GREEN LED + DIODE MODULE (STANDARD POLARITY)			
6 - 24 V DC 28 - 60 V DC 110 - 220 V DC	99.01.9.024.99 99.01.9.060.99 99.01.9.220.99	99.02.9.024.99 99.02.9.060.99 99.02.9.220.99	99.80.9.024.99 99.80.9.060.99 99.80.9.220.99
GREEN LED + DIODE MODULE (INVERTED POLARITY)			
6 - 24 V DC 28 - 60 V DC 110 - 220 V DC	99.01.9.024.79 99.01.9.060.79 99.01.9.220.79	99.02.9.024.79 99.02.9.060.79 99.02.9.220.79	
GREEN LED + VARISTOR			
6 - 24 V AC/DC 28 - 60 V AC/DC 110 - 240 V AC/DC	99.01.0.024.98 99.01.0.060.98 99.01.0.230.98	99.02.0.024.98 99.02.0.060.98 99.02.0.230.98	99.80.0.024.98 99.80.0.060.98 99.80.0.230.98
GREEN LED			
6 - 24 V AC/DC 28 - 60 V AC/DC 110 - 240 V AC/DC	99.01.0.024.59 99.01.0.060.59 99.01.0.230.59	99.02.0.024.59 99.02.0.060.59 99.02.0.230.59	99.80.0.024.59 99.80.0.060.59 99.80.0.230.59
DIODE MODULE (STANDARD POLARITY)			
6 - 220 V DC	99.01.3.000.00	99.02.3.000.00	99.80.3.000.00
DIODE MODULE (INVERTED POLARITY)			
6 - 220 V DC	99.01.2.000.00	99.02.2.000.00	
RC MODULE			
6 - 24 V AC/DC 28 - 60 V AC/DC 110 - 240 V AC/DC	99.01.0.024.09 99.01.0.060.09 99.01.0.230.09	99.02.0.024.09 99.02.0.060.09 99.02.0.230.09	99.80.0.024.09 99.80.0.060.09 99.80.0.230.09
RESIDUAL CURRENT BYPASS MODULE			
110 - 240 V AC	99.01.8.230.07	99.02.8.230.07	99.80.8.230.07

Voltage-current characteristic when switching an ohmic load (fig. 1).

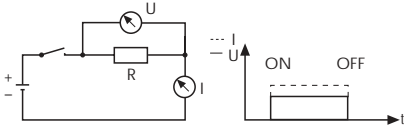

Voltage-current characteristic when switching a relay coil (fig. 2).

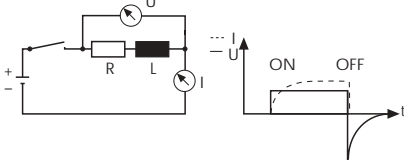

### Switching Relay Coils.

When switching a resistive load, the current follows the phase of the voltage directly (Fig 1).

When switching relay coils the current and voltage waveforms are different due to the inductive nature of the coil (Fig 2). A brief explanation of this mechanism is as follows.

On energising the coil, the build up of the magnetic field gives rise to counter electromotive forces which in turn delay the rise in coil current. On de-energisation, the sudden interruption of the coil current causes a sudden collapse of the magnetic field, which in turn induces a high voltage of reverse polarity across the coil. This reverse polarity voltage peak can reach a value typically 15 times higher than the supply voltage, and as a consequence can disturb or destroy electronic devices.

To counteract this potentially damaging effect, relays coils can be suppressed with a Diode, a Varistor (voltage dependent resistor) or a RC (resistor/capacitor) module – dependent on the operating voltage. (See below for descriptions of the various Modules available.)

Whilst the above description is based on the working of a DC coil, the reverse polarity voltage peak on de-energisation applies similarly to AC coils. However, when energising AC coils there will also be a coil inrush current of 1.3 to 1.7 times the nominal coil current – dependent on coil size. If coils are fed via a transformer (and particularly if several are energised at the same time) then this may need to be taken into account when calculating the VA rating of the transformer.

Diagrams		Functions
<p>99.01.9.xxx.99 only 99.80.9.xxx.99 only</p>	<p>99.02.9.xxx.99 only</p>	<p><b>GREEN LED +DIODE MODULE (STANDARD POLARITY)</b> Recovery diode modules + LED are used for DC only. The reverse voltage peaks of the coil are short circuited by the recovery diode (positive to terminal A1). The release time increases by an approximate factor of 3. If an increase of the release time is undesirable use a Varistor or RC module. The LED indicator lights up when the coil is energized.</p>
<p>99.01.9.xxx.79 only</p>	<p>99.02.9.xxx.79 only</p>	<p><b>GREEN LED +DIODE MODULE (INVERTED POLARITY)</b> Recovery diode modules + LED are used for DC only. The reverse voltage peaks of the coil are short circuited by the recovery diode (positive to terminal A2). The release time increases by an approximate factor of 3. If an increase of the release time is undesirable use a Varistor or RC module. The LED indicator lights up when the coil is energized.</p>
		<p><b>GREEN LED + VARISTOR</b> LED modules + Varistor are used for both AC and DC coils. The reverse voltage peaks of the relay coil are limited by the Varistor to approximately 2.5 times the nominal voltage of the supply. When using DC coils it is essential that positive is connected to terminal A1. The relay release time increases insignificantly.</p>
		<p><b>GREEN LED</b> LED modules are used for AC and DC. The LED indicator lights up when the coil is energized. When using DC it is essential that positive is connected to terminal A1.</p>
<p>99.01.3.000.00 only 99.80.3.000.00 only</p>	<p>99.02.3.000.00 only</p>	<p><b>DIODE MODULE (STANDARD POLARITY)</b> Recovery diode modules are used for DC only. The reverse voltage peaks of the coil are short circuited by the recovery diode (positive to terminal A1). The release time increases by an approximate factor of 3. If an increase of the release time is undesirable use a Varistor or RC module.</p>
<p>99.01.2.000.00 only</p>	<p>99.02.2.000.00 only</p>	<p><b>DIODE MODULE (INVERTED POLARITY)</b> Recovery diode modules are used for DC only. The reverse voltage peaks of the coil are short circuited by the recovery diode (positive to terminal A2). The release time increases by an approximate factor of 3. If an increase of the release time is undesirable use a Varistor or RC module.</p>
		<p><b>RC MODULE</b> RC circuit modules are used for AC and DC coils. The reverse voltage peaks of the coil are limited by the RC module to approximately 2.5 times the nominal voltage of the supply. The relay release time increases insignificantly.</p>
		<p><b>RESIDUAL CURRENT BYPASS MODULE</b> Bypass modules are advisable if 110 or 230v AC relays show any tendency to fail to release. Failure to release can be caused by residual currents from AC proximity switches or inductive coupling caused through long parallel lying AC control lines.</p>



 **FINDER FRANCE Sarl**  
Avenue d'Italie - BP 40  
Zone Ind. du Pré de la Garde  
F - 73302 ST. JEAN  
DE MAURIENNE Cédex  
Tel. +33/479/83 27 27  
Fax +33/479/59 80 04  
**Finder.FR@findernet.com**

 **S.P.R.L. FINDER BELGIUM B.V.B.A.**  
Bloemendael, 5  
B - 1547 BEVER  
Tel. +32/54/30 08 68  
Fax +32/54/30 08 67  
**Finder.BE@findernet.com**

 **FINDER RELAIS NEDERLAND B.V.**  
Dukdalfweg 51  
NL - 1041 BC AMSTERDAM  
Tel. +31/20/615 65 57  
Fax +31/20/617 89 92  
**Finder.NL@findernet.com**

 **FINDER GmbH**  
Eisenstrasse 30  
D - 65428 RÜSSELSHEIM  
Tel. +49/6142/8770  
Fax +49/6142/87777  
**Finder.DE@findernet.com**

 **FINDER RELAIS VERTRIEBS GmbH**  
Aspangbahnstraße 2  
A - 2361 LAXENBURG  
Tel. +43/2236/86 41 36 - 0  
Fax +43/2236/86 41 36 36  
**Finder.AT@findernet.com**

 **FINDER CZ, s.r.o.**  
Sitiřkovská 110/3  
CZ - 180 00 PRAHA 8  
Tel. +420/2 8688 9504  
Fax +420/2 8688 9505  
**Finder.CZ@findernet.com**

 **FINDER (SCHWEIZ) AG**  
Industriestrasse, 1a  
Postfach 23  
CH - 8157 DIELSDORF (ZH)  
Tel. +41/1/885 30 10  
Fax +41/1/885 30 20  
**Finder.CH@finder-relais.ch**

 **FINDER P.L.C.**  
Opal Way - Stone Business Park  
STONE, STAFFORDSHIRE,  
ST15 0SS - UK  
Tel. +44/1785/818100  
Fax +44/1785/815500  
**Finder.UK@findernet.com**

 **FINDER AB**  
Stationsvägen, 1  
SE - 435 25 MÖLNLYCKE  
Tel. +46/31/88 00 99  
Fax +46/31/88 06 04  
**Finder.SE@findernet.com**

 **FINDER ELECTRICA S.L.**  
P.O. Box 5086  
E - 46080 VALENCIA  
Tel. +34/96/346 57 34  
Tel. +34/96/346 57 32  
Fax +34/96/349 00 57  
**Finder.ES@findernet.com**

 **FINDER RELAYS, INC.**  
4465 Commerce Drive, Suite: 103  
Buford, GA 30518 - U.S.A.  
Tel. +1/770/271-4431  
Fax +1/770/271-7530  
**Finder.US@findernet.com**

 **FINDER COMPONENTES Ltda**  
Rua Olavo Bilac, 315  
BAIRRO: SANTO ANTONIO  
SÃO CAETANO DO SUL - SÃO PAULO  
CEP 09530260 - BRASIL  
Tel. +55/11/4227 1550  
Fax +55/11/4227 4313  
**Finder.BR@findernet.com**

 **finder®**  
[www.findernet.com](http://www.findernet.com)

 **FINDER SpA**  
Via Drubiaglio, 14  
I - 10040 ALMESE (TO)  
Tel. +39/011.9346211  
Fax +39/011.9359079  
**Export@findernet.com**

Distributor

FINDER reserves the right to alter characteristics at any time without notice. FINDER assumes no liability for damage to people or things, caused as a result of the incorrect use or application of its products.