

DRAWING NUMBER:
HG02-065-05

CABLE CUTTING
CABLE SOURCE :
1. BAO HING(SHENZHEN).
2. TONG YUAN(SHENZHEN).

ASSEMBLY :

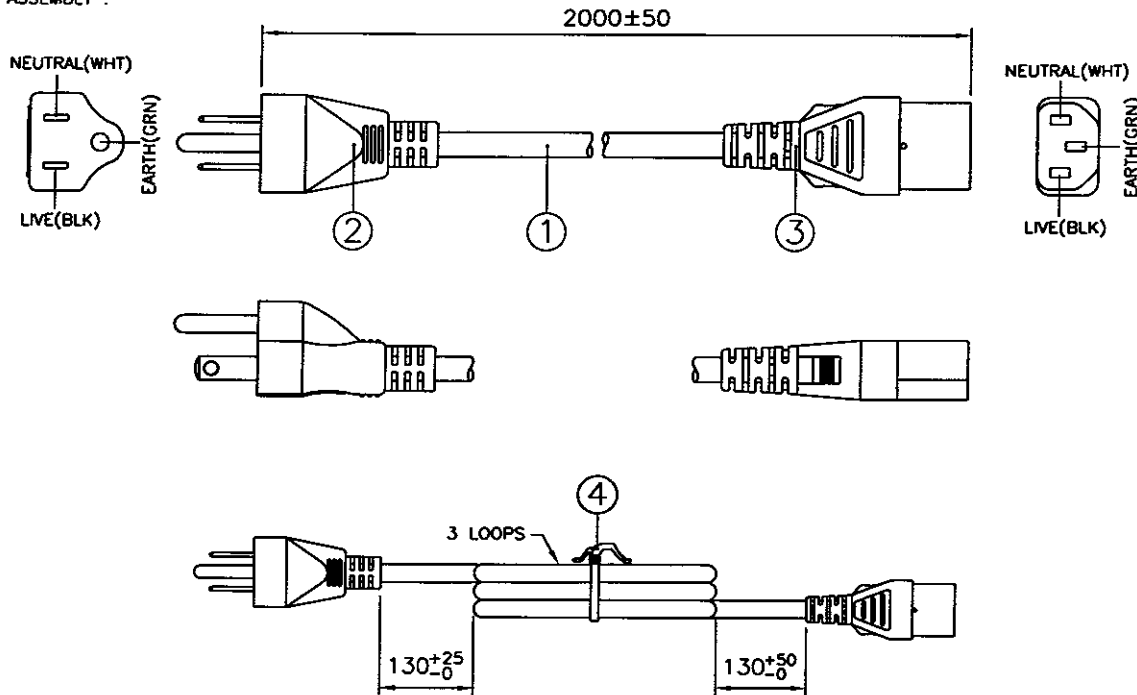

Notes :

1. ALL DIMENSIONS IN mm.
2. PLUG AND CONNECTOR MARKING : REFER TO MARKING DRAWING NO. : VP-0108 AND VC-0102 RESPECTIVELY.
3. PLUG AND CONNECTOR DETAILS : REFER TO PRODUCT DRAWING NO. : P-0044 AND C-0062 RESPECTIVELY.
4. THIS PART CAN BE MANUFACTURED AT ANY LOCATION WHICH HAS SAFETY APPROVAL.

| REV. | ECN REF. NO. | DESCRIPTION | DATE |
|------|--------------|------------------|----------|
| 1 | HG02-065-05 | INITIAL RELEASE. | 18/02/05 |

FOR ENQUIRY ONLY
NOT FOR MASS PRODUCTION

APPROVAL BY : _____

DATE : _____

| | | | |
|---|-------------------------------------|---------|---|
| 4 | 6" PE TIE BLK | 6310056 | 1 |
| | IP60G NL7976B BLK | 4100115 | - |
| 3 | MOLDED CONNECTOR V1625 (10A 125V) | V1625 | 1 |
| | IP40G NL792B BLK | 4100017 | - |
| 2 | MOLDED PLUG PS204 (10A 125V) | PS204 | 1 |
| 1 | SVT 18/3 60°C BWG BLK PVC LEAD FREE | 1810120 | - |

| S/N | DESCRIPTION | ITEM NUMBER | QTY |
|---|-------------|-------------|-----|
| TITLE : NORTH-AMERICAN POWER SUPPLY CORDSET (ROHS FR) | | PAGE : 1/1 | |
| CUSTOMER : VPE/FARNELL COMP. | | HG02-065-05 | |
| CUSTOMER PART NUMBER : X-210705A | | REVISION | |
| F/G CODE : - - - - | | 1 | |

| | | | | | |
|---------|--------|---------|--------------|------------|---|
| SALES : | QA : | ENGRG : | CHECKED BY : | DRAWN BY : | Volex (Asia) Pte Ltd <small>Confidential property of Volex. Information contained herein shall not be disclosed to others, reproduced or used for any other purposes except as authorized in writing by an authorized official of Volex Asia.</small> |
| DATE : | DATE : | DATE : | DATE : | DATE : | |
| | | | | | |
| | | | | | |