

THIS DRAWING IS UNPUBLISHED. RELEASED FOR PUBLICATION SEPTEMBER ,2006.  
 © COPYRIGHT 2006 BY TYCO ELECTRONICS CORPORATION. ALL RIGHTS RESERVED.

Loc	DIST	REVISIONS					
		P	LTR	DESCRIPTION	DATE	DWN	APVD
E	B	A		FIRST ISSUE	26SEP06	JMS	FWK
			1.1	9-1478242-0	RG58C/U, 141A/U, 303/U, URM43, 76, BELDEN 9907, KX15		5-1814802-3
			1.1	9-1478242-0	RG58C/U, 141A/U, 303/U, URM43, 76, BELDEN 9907, KX15		5-1814802-2
			0.57	9-1478242-0	RG174A/U, 188A/U, 316/U, URM95, KX3B, KX22A		5-1814802-1
			0.57	9-1478242-0	RG174A/U, 188A/U, 316/U, URM95, KX3B, KX22A		5-1814802-0
DIMENSIONS						CABLE GROUPS	
						PART NO.	

- NOTES**
- 1 SINGLE PACK IN ACCORDANCE WITH AMP SPEC 107-3275
  - 2 100 TRAY PACK IN ACCORDANCE WITH AMP SPEC 107-3275
  - 3 Au PLATING
  - 4 Ni PLATING
  - 5 HAND TOOL: 9-1478240-0
  - 6 DIE SET: SEE TABLE
  - 7 ELECTRICAL CHARACTERISTICS  
 FREQUENCY RANGE: DC - 4 GHz  
 NOMINAL IMPEDANCE: 50 Ohm  
 INSULATION RESISTANCE: 5000 MOhm  
 WORKING VOLTAGE: 500 Volts RMS at Sea Level  
 DIELECTRIC WITHSTAND VOLTAGE: 1500 Volts RMS Max  
 CONTACT RESISTANCE:  
 CENTRE CONTACT: 1.50 mOhm Max  
 OUTER CONTACT: 1.00 mOhm Max  
 VSWR @ 4GHz: 1.30:1 Max  
 INSERTION LOSS dB @ x 3 GHz: 0.20 Max
  - 8 MECHANICAL CHARACTERISTICS  
 COUPLING NUT RETENTION FORCE: N/A  
 CABLE RETENTION FORCE: RG58C/U: 170N Min  
 CABLE RETENTION FORCE: RG174A/U: 85N Min  
 MOUNT NUT RECOMMENDED TORQUE: 4N  
 DURABILITY: 50 Cycles Min
  - 9 ENVIRONMENTAL CHARACTERISTICS  
 OPERATING TEMPERATURE: -65 to +85 DegC
  - 10 FOR TECHNICAL DATA REFER TO YOUR LOCAL TYCO ELECTRONICS SALES OFFICE
  - 11 ALL DIMENSIONS ARE NOMINAL FOR REFERENCE ONLY UNLESS OTHERWISE STATED

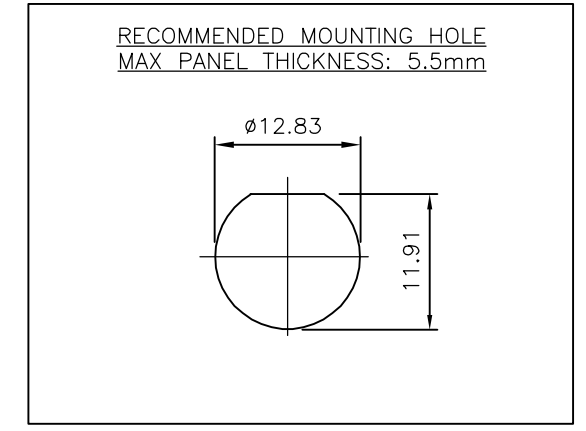
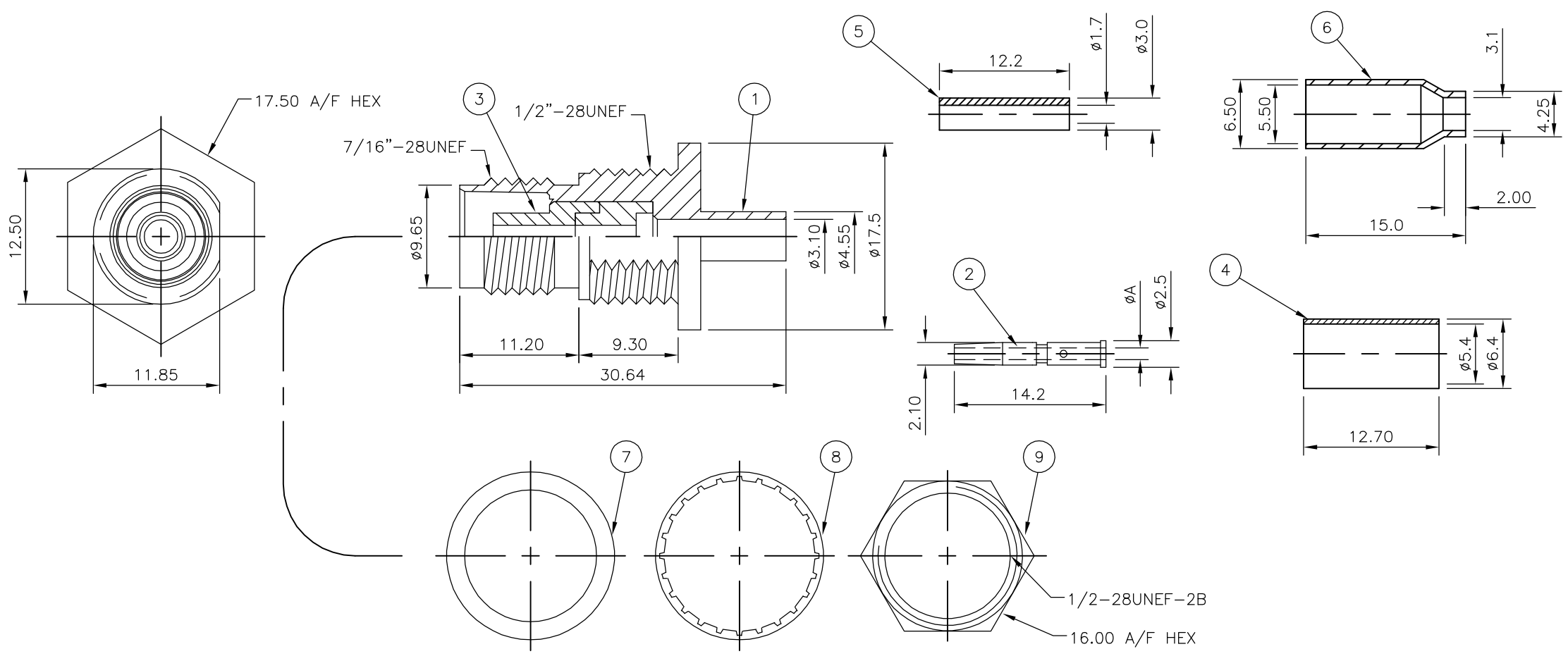

QTY	UNIT	MATERIAL	DESCRIPTION	ITEM
1	1	BRASS	HEXAGON NUT	9
1	1	PHOSPHOR BRONZE	WASHER	8
1	1	SILCON RUBBER	GASKET	7
-	-	BRASS	FERRULE	6
-	-	NYLON	PUSHER SLEEVE	5
1	1	BRASS	FERRULE	4
1	1	DELTRIN	INSULATOR	3
1	1	PHOSPHOR BRONZE	CONTACT	2
1	1	ZINC ALLOY	BODY	1
5	35	25	15	0
			MATERIAL	DESCRIPTION
				ITEM

THIS DRAWING IS A CONTROLLED DOCUMENT.

DIMENSIONS: mm

TOLERANCES UNLESS OTHERWISE SPECIFIED

0 PLC	±
1 PLC	±
2 PLC	±
3 PLC	±
4 PLC	±
ANGLES	±

MATERIAL: SEE TABLE

FINISH: SEE TABLE

APPROVALS:

DWN	J.SANDWELL	26SEP06
CHK	S.PARLOW	26SEP06
APVD	F.WHEELER-KING	26SEP06

NAME: TNC BULKHEAD CRIMP JACK - 50 OHM

APPLICATION SPEC: SEE SHEET 2

WEIGHT: -

CUSTOMER DRAWING

SCALE: NTS

SHEET 1 OF 2

REV A

RESTRICTED TO: -

SIZE: A2

CAGE CODE: 00779



DRAWING NO: C=1814802

TYCO Electronics Tyco Electronics Corporation Bideford, UK, EX39 4HE

THIS DRAWING IS UNPUBLISHED. RELEASED FOR PUBLICATION SEPTEMBER, 2004.  
 © COPYRIGHT 2006 BY TYCO ELECTRONICS CORPORATION. ALL RIGHTS RESERVED.

LOC		DIST		REVISIONS			
P	LTR	DESCRIPTION	DATE	DWN	APVD		
-	-	SEE SHEET 1	-	-	-		

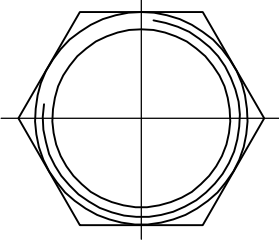
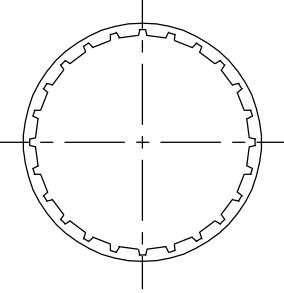
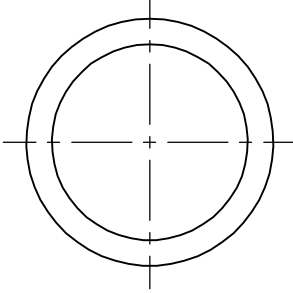
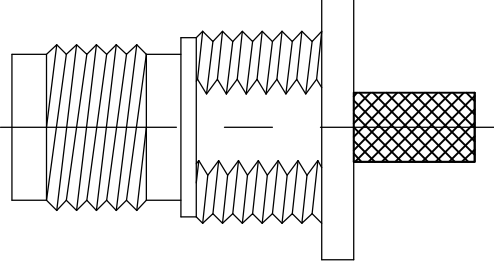
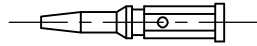
COMPONENTS

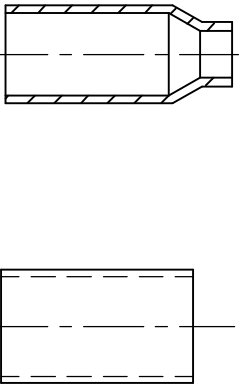
HEX NUT (ITEM 9)	LOCK WASHER (ITEM 8)	GASKET (ITEM 7)	MAIN BODY (ITEM 1,3,)	CENTRE CONTACT (ITEM 2)	PUSHER SLEEVE (ITEM 5)	CRIMP FERRULES (ITEM 4 & 6)
						

ASSEMBLY INSTRUCTION

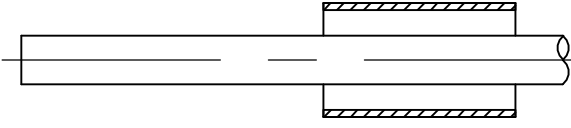
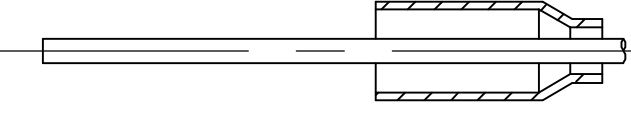
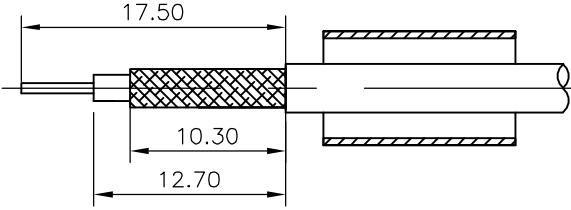
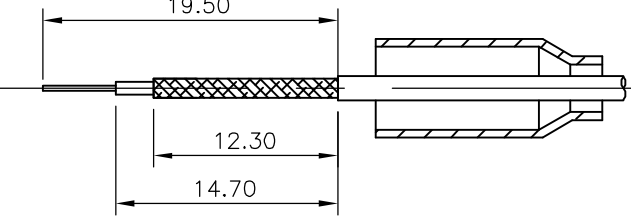
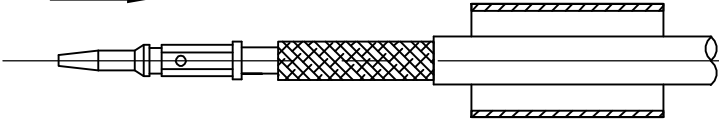
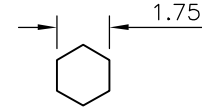
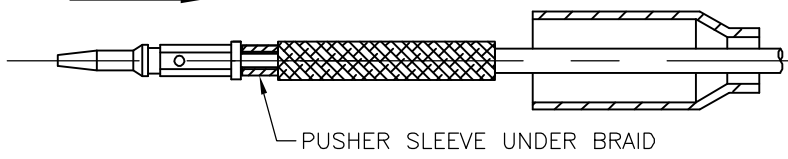
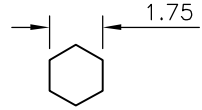
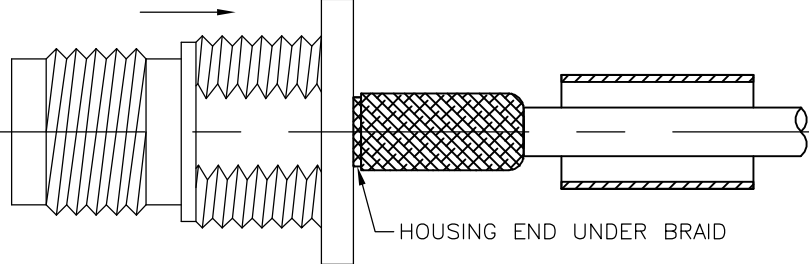
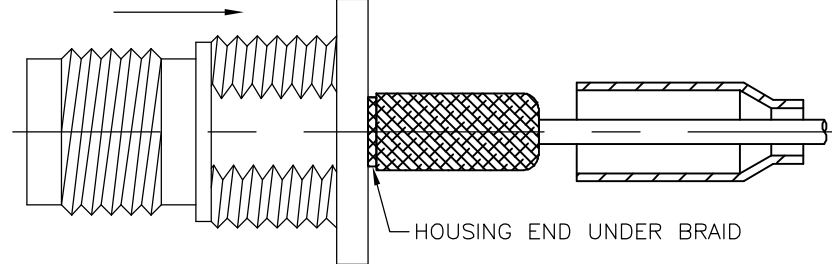
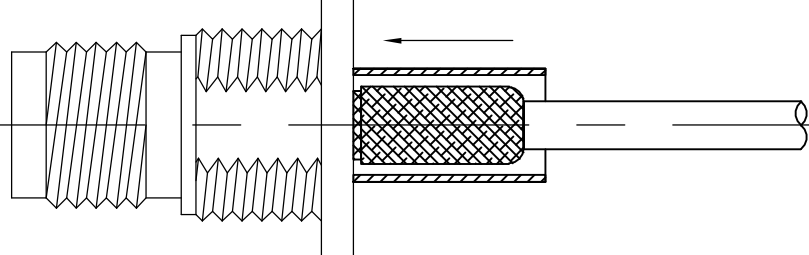
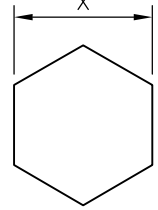
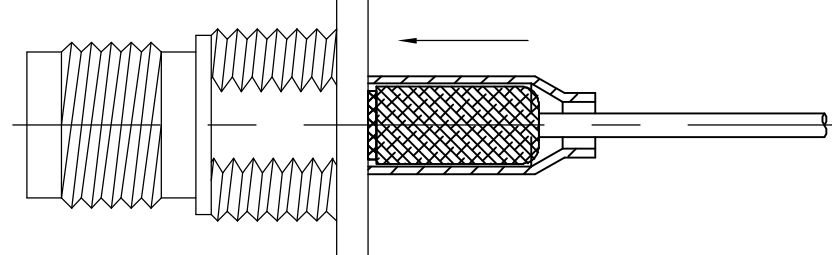
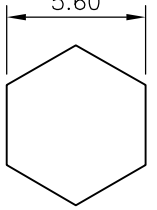
CABLES: RG59B/U, 62A/U, 140/U, 210/U, URM90, KX 6A, KX 25, KX 52, KX 53, RG58C/U, 141A/U, URM43, 76, BELDEN 9907, KX 15	CABLES: RG179B/U, 187A/U, URM111
<p><b>STEP 1</b></p> <p>1. SLIDE METAL CRIMP FERRULE OVER CABLE</p> 	<p><b>STEP 1</b></p> <p>1. SLIDE METAL CRIMP FERRULE OVER CABLE</p> 
<p><b>STEP 2</b></p> <p>1. STRIP CABLE TO DIMENSIONS AS SHOWN</p> 	<p><b>STEP 2</b></p> <p>1. STRIP CABLE TO DIMENSIONS AS SHOWN</p> 
<p><b>STEP 3</b></p> <p>1. FIT CONTACT OVER CENTRE CONDUCTOR TO BUTT AGAINST DIELECTRIC.            2. CRIMP USING TOOL AS NOTES ON PAGE 1.</p>  <p>RECOMMENDED CENTRE CONTACT A/F HEX</p> 	<p><b>STEP 3</b></p> <p>1. SLIDE ITEM 10 PUSHER SLEEVE OVER DIELECTRIC BEFORE FITTING THE CONTACT.            2. FIT CONTACT OVER CENTRE CONDUCTOR TO BUTT AGAINST DIELECTRIC.            3. CRIMP USING TOOL AS NOTES ON PAGE 1.</p>  <p>RECOMMENDED CENTRE CONTACT A/F HEX</p> 
<p><b>STEP 4</b></p> <p>1. PRESS SUB-ASSEMBLY INTO BODY, UNTIL CONTACT IS FULLY LOCATED BY AN AUDIBLE CLICK.            2. ENSURE THAT KNURLED HOUSING INSERTS BETWEEN THE DIELECTRIC AND CABLE BRAID.</p>  <p>HOUSING END UNDER BRAID</p>	<p><b>STEP 4</b></p> <p>1. PRESS SUB-ASSEMBLY INTO BODY, UNTIL CONTACT IS FULLY LOCATED BY AN AUDIBLE CLICK.            2. ENSURE THAT KNURLED HOUSING INSERTS BETWEEN THE PUSHER SLEEVE AND CABLE BRAID.</p>  <p>HOUSING END UNDER BRAID</p>
<p><b>STEP 5</b></p> <p>1. SLIDE CRIMP FERRULE ALONG THE CABLE UNTIL IT BUTTS AGAINST THE HOUSING BODY.            2. CRIMP USING TOOL AS NOTED ON PAGE 1.            3. CRIMP DIMENSION X IS:-            RG59B (SEE PAGE 1 FOR FULL CABLE LIST) = 6.50            RG58C/U (SEE PAGE 1 FOR FULL CABLE LIST) = 5.60</p>  <p>RECOMMENDED CRIMP SLEEVE A/F HEX</p> 	<p><b>STEP 5</b></p> <p>1. SLIDE CRIMP FERRULE ALONG THE CABLE UNTIL IT BUTTS AGAINST THE BODY HOUSING.            2. CRIMP USING TOOL AS NOTED ON PAGE 1.            3. CRIMP DIMENSION AS SHOWN.</p>  <p>RECOMMENDED CRIMP SLEEVE A/F HEX</p> 

THIS DRAWING IS A CONTROLLED DOCUMENT.

DWN	J.SANDWELL	26SEP06
CHK	S.PARLOW	26SEP06
APVD	F.WHEELER-KING	26SEP06
PRODUCT SPEC		
APPLICATION SPEC		
WEIGHT		
CUSTOMER DRAWING		

**tyco Electronics** Tyco Electronics Corporation  
Bideford, UK, EX39 4HE

NAME: TNC BULKHEAD CRIMP JACK - 50 OHM

SIZE: A2 CAGE CODE: 00779 DRAWING NO: C=1814802 RESTRICTED TO: -

SCALE: NTS SHEET 2 OF 2 REV A